



R32 MULTI-ZONE CONDENSER INSTALLATION & OWNER'S MANUAL

MODELS

ACIQ-18Z-E-M2

ACIQ-24Z-E-M3

ENGLISH

- Please read this installation manual carefully and thoroughly before installing the unit.
- Take care of this manual for future reference.

Version Date: 10-15-25



Contents

Warning	1
Safety Precaution	3
Notices For Usage	4
Component Name	5
Notices Of Installation	5
Before Installation.....	7
Installation Of The Outdoor Unit	7
Electrical Connections	14
Testing And Inspection	15
Fault Code	16
Maintenance Notice	22

ENGLISH

Note:

- *All the illustrations in this manual are for explanation purpose only.*
- *Your air conditioner may be slightly different. The actual shape shall prevail.*
- *They are subject to change without notice for future improvement.*

Warning

※ FCC WARNING

WARNING: Changes or modifications to this unit not expressly approved by the party responsible for compliance could void the user's authority to operate the equipment.

※ FCC STATEMENT

This device complies with Part 15 of the FCC Rules. Operation is subject to the following two conditions:

(1) this device may not cause harmful interference, and (2) this device must accept any interference received, including interference that may cause undesired operation.

NOTE: This equipment has been tested and found to comply with the limits for a Class B digital device, pursuant to part 15 of the FCC Rules. These limits are designed to provide reasonable protection against harmful interference in a residential installation. This equipment generates, uses and can radiate radio frequency energy and, if not installed and used in accordance with the instructions, may cause harmful interference to radio communications. However, there is no guarantee that interference will not occur in a particular installation. If this equipment does cause harmful interference to radio or television reception, which can be determined by turning the equipment off and on, the user is encouraged to try to correct the interference by one or more of the following measures:

- Reorient or relocate the receiving antenna.
- Increase the separation between the equipment and receiver.
- Connect the equipment into an outlet on a circuit different from that to which the receiver is connected.
- Consult the dealer or an experienced radio/TV technician for help.

※ IC STATEMENT





This device complies with Industry Canada licenceexempt RSS standard(s).

Operation is subject to the following two conditions: (1) this device may not cause interference, and (2) this device must accept any interference, including interference that may cause undesired operation of the device.

※ IC STATEMENT

This equipment complies with FCC's and IC's RF radiation exposure limits set forth for an uncontrolled environment. The antenna(s) used for this transmitter must be installed and operated to provide a separation distance of at least 7-7/8in.(20cm) from all persons and must not be collocated or operating in conjunction with any other antenna or transmitter. Installers must ensure that 7-7/8in.(20cm) separation distance will be maintained between the device (excluding its handset) and users.

Warning

Symbol	Note	Explanation
 A2L	WARNING	This symbol shows that this appliance uses a flammable refrigerant. If the refrigerant is leaked and exposed to an external ignition source, there is a risk of fire. (Only for the AC with UL or ETL-MARKING, UL60335-2-40)
	CAUTION	This symbol shows that the operation manual should be read carefully.
	CAUTION	This symbol shows that a service personnel should be handling this equipment with reference to the installation manual.
	CAUTION	This symbol shows that information is available such as the operating manual or installation manual.

NOTE:

The Air conditioner with R32 refrigerant, if roughly treated, may cause serious harm to the human body or surrounding things.

- The room space and maximum refrigerant charge requirements are shown in the table.
- If ice has formed on the unit, do not use means to accelerate the defrosting process other than those recommended by the manufacturer.
- Do not use any cleaners on the unit other than what's approved by the manufacture.
- Do not pierce or burn air conditioner and ensure that the refrigerant pipeline is not damaged.
- The appliance must be stored in a room without continuously operating ignition sources (for example: open flames, an operating gas appliance or an operating electric heater).
- Notice that the refrigerant may be odorless.
- The storage of the air conditioner should be in a location that's able to prevent unintentional damage to the unit.
- Be sure to follow all local codes and safety requirements.

Room Space and Maximum Refrigerant Charge Requirements

Refrigerant Type	Allowable Refrigerant Charge Amount, (oz(kg))	Min. Floor Area For Installation, (ft ² (m ²))
R32	< 64.9 (< 1.84)	75.35 (7)
	64.9~82.54 (1.84~2.34)	96.88 (9)
	82.58~100.18 (2.341~2.84)	113.02 (10.5)
	100.21~117.82 (2.841~3.34)	134.55 (12.5)
	117.85~135.45 (3.341~3.84)	150.69 (14)
	135.49~153.09 (3.841~4.34)	193.75 (18)

ENGLISH

Safety Precaution

Incorrect installation or operation by not following these instructions may cause harm or damage to people, properties, etc. The seriousness is classified by the following indications:

 **WARNING**

This symbol indicates the possibility of death or serious injury.

 **CAUTION**

This symbol indicates the possibility of injury or damage to properties.

 **Things you shouldn't do.**

 **Follow the instructions.**

 **Cut the power off.**

 **Environmental notices.**

 **WARNING** 

- **Don't** connect the ground wire to the gas pipeline, water pipeline, lightning rod, or telephone earth wire.
- **Don't** pull the power cable. Pulling the power cable could result in damage to the unit and electrical shock.
- **Don't** cut off main power switch during operating or with wet hands. It may cause electric shock.
- **Don't** let the air conditioner blow against the heater appliance. Otherwise it will lead to incomplete combustion, thus causing poisoning.
- **Don't** let the remote control and the indoor unit watered or being too wet. Exposure to excessive moisture may cause damage to the unit and or electrical shock.
- **Don't** install the air conditioner in a place where there is flammable gas or liquid unless the distance is equal to or greater than 3-1/4ft.(1m) apart.
- **Don't** use any unapproved liquid or cleaning agent to clean the air conditioner.
- **Don't** attempt to repair the air conditioner by yourself. Incorrect repairs may cause fire or explosion. Contact a qualified service technician for all service requirement.
- **Don't** operate the air conditioner during a lightning storm. The power should be switched off to prevent danger or injury.
- **Don't** put hands or any objects into the air inlets or outlets. This may cause personal injury or damage to the unit.
- **Don't** block air inlet or air outlet. Otherwise, the cooling or heating capacity will be diminished, or cause the system to stop operating.

 **WARNING** 

- **This** appliance is not intended for use by persons (including children) with reduced physical, sensory or mental capabilities, or lack of experience and knowledge, unless they have been given supervision or instruction concerning use of the appliance by a person responsible for their safety.
- **Children** should be supervised to ensure that they do not play with the appliance.
- **Please** mount the system on a secure surface to prevent the unit from falling and causing injury or damage.
- **The** appliance shall be installed in accordance with national wiring regulations.
- **If** the supply cord is damaged, it must be replaced by the manufacturer, its service agent or similarly qualified persons in order to avoid a hazard.
- **Contact** a qualified service technician for all service requirements.
- **The** air conditioner must be grounded. Incomplete grounding may result in electric shocks.
- **Make sure** that the system has its own dedicated electrical circuit and that all electrical work is conducted by an individual that is certified or licensed to do such work in the state or region in which the insulation is taking place.
- **Ensure** the following objects are not under the indoor unit: Microwaves, ovens and other hot objects. Computers and other high electrostatic appliances. Electrical sockets. Items susceptible to water damage.
- **The** piping between indoor and outdoor unit shall not be reused, unless they can be properly flushed and re-flared.
- **The** specifications for electrical requirements are listed on the data plate of the unit.

 **WARNING** 

- **Always** switch off the device and cut the power supply when the unit is not in use for long time so as to ensure safety.
- **Always** switch off the device and cut the power supply before performing any maintenance or cleaning. Otherwise, it may cause electric shock or damage.
- **WARNING RISK OF ELECTRIC SHOCK. CAN CAUSE INJURY OR DEATH:** System contains oversize protective earthing (grounding) terminal which shall be properly connected.
- **WARNING RISK OF ELECTRIC SHOCK. CAN CAUSE INJURY OR DEATH:** System contains two independent protective earthing (grounding) terminals which both shall be properly connected and secured.
- **If** your air conditioner is not fitted with a supply cord and a plug, an all-pole switch must be installed in the fixed wiring and the distance between contacts should be no less than 0.12in (3.0 mm).

Safety Precaution

⚠ WARNING



This product contains fluorinated greenhouse gases.

- **Refrigerant** leakage will contribute to climate change.
- **Never** tamper with the refrigerant system or attempt repair without proper training and compliance to local and national codes.
- **The** refrigerant in this system has a lower global warming potential (GWP) than a refrigerant with higher GWP, if leaked to the atmosphere. This appliance contains a refrigerant fluid with a GWP equal to [675]. This means that if 35 oz (1kg) of this refrigerant fluid would be leaked to the atmosphere, the impact on global warming would be [675] times higher than 35 oz (1kg) of CO₂, over a period of 100 years.

⚠ CAUTION



- **Don't** operate the system with windows or doors open. Doing so will limit the system effectiveness.
- **Don't** stand on the top of the outdoor unit or place heavy objects on it. This could cause personal injuries or damage to the unit.
- **Don't** use the system for other purposes, such as drying clothes, preserving foods, etc.
- **Don't** apply the cold air to the body for a long time. It will deteriorate your physical conditions and cause health problems.

⚠ CAUTION



- **Appropriate** adjustments of the setting temperature can prevent the waste of electricity.
- **Use** an all-pole disconnection type breaker with at least 1/8 in. (3mm) between the contact point gaps that provide full disconnection under overvoltage category III.

- **If** your air conditioner is permanently connected to the fixed wiring, a residual current device (RCD) having rated residual operating current not exceeding 30 mA should be installed in the fixed wiring.
- **The** power supply circuit should have leakage protector and air switch of which the capacity should be more than 1.5 times of the maximum current.
- **Regarding** the installation of the air conditioners, please refer to the below paragraphs in this manual.

E-Waste

Meaning of crossed out wheeled dustbin:

Do not dispose of electrical appliances as unsorted municipal waste, use separate collection facilities.

Contact you local government for information regarding the collection systems available.

If electrical appliances are disposed of in landfills or dumps, hazardous substances can leak into the groundwater and get into the food chain, damaging your health and well-being. When replacing old appliances with new ones, the retailer is legally obligated to take back your old appliance for disposals at least free of charge.



ENGLISH

Notices For Usage

Operating Range

- Operating the unit outside the recommended temperature range may have an impact on the system performance. When the temperature is too high, the air conditioner may trip the circuit breaker causing the air conditioner to shut down. When the temperature is too low, the outdoor heat exchanger may generate excessive moisture, leading to water dripping from the unit.
- In long-term cooling or dehumidification with a relative humidity of above 80%, doors and windows should be closed to prevent the indoor unit from generating too much water and causing leaks.

Type	Range	Indoor	Outdoor
Regular	Cooling	60.8°F~89.6°F (16°C~32°C)	-13~125.6°F (-25~52°C)
	Heating	50°F~89.6°F (10°C~32°C)	-13~75.2°F (-25~24°C)

Notices For Usage

Notes for Heating

- The fan of the indoor unit will not start immediately when the heating cycle has started. The unit will warm up and then start blowing air to avoid blowing out cool air.
- When it is cold and wet outside, the outdoor unit will develop frost over the heat exchanger which over time will cause the system to start the defrost function.
- During defrost, the air conditioner will stop heating for about 5-12 minutes.
- Vapor may come out from the outdoor unit during defrost. This is not a malfunction, but a result of fast defrost.
- Heating will resume after defrost is complete.

Notes for Turning Off

- When the air conditioner is turned off, the main controller will automatically decide whether to stop immediately or after running for dozens of seconds with lower frequency and lower air speed.

Component Name

Indoor Unit:

Wall-Mounted Air Handler



Outdoor Unit:



Notices Of Installation

Important Notices

- This unit must be installed by a certified contractor to avoid:
Damage to the unit
Refrigerant leaking in the atmosphere
Electrical shock
Burns from refrigerant
Other serious injuries including death
- Leak test must be made after installation.
- To move and install air conditioner to another place, please contact our local authorized contractor.

Installation Environment Inspections

- Check nameplate of outdoor machine to make sure whether the refrigerant is R32.
- Check the floor space of the room. The space shall not be less than usable space in the specification.
- The outdoor unit shall be installed at a well-ventilated place.
- Check the surrounding environment of installation site: R32 shall not be installed in the enclosed reserved space of a building.
- When using electric drill to make holes in the wall, check first whether there is pre-buried pipeline for water, electricity and gas. It is suggested to use the reserved hole in the roof of the wall.

Unpacking Inspections

- Open the box and check air conditioner in area with good ventilation and without ignition source.
- Note: Operators are required to wear anti-static devices.
- It is necessary to check whether there is refrigerant leakage before opening the box of outdoor machine; stop installing the air conditioner if leakage is found.
- Fire prevention equipment should be prepared before starting the installation.
- Then check the refrigerant pipeline to see if there is any damage or leaks.

Requirements for Installation Position

- Avoid places of flammable or explosive gas leakage or where there is poor ventilation.
- Avoid places subject to strong electric/magnetic fields like microwaves and fluorescent lights.
- Avoid places like subject to noise and resonance like walls above a sleeping area.
- Avoid severe natural conditions (e.g. strong wind, direct sunshine or high temperature heat sources).
- Avoid places within the reach of children.
- Shorten the connection between the indoor and outdoor units as much as possible for best performance.
- Select a location where it is easy to perform service and repair.
- The outdoor unit shall not be installed in any way that could occupy an aisle, stairway, exit, fire escape, catwalk or any other public area.
- The outdoor unit shall be installed as far as possible from the doors and windows of the neighbors as well as plants.

Requirements for Operations at Raised Height

- When carrying out installation at 6-9/16ft. (2m) or higher above the base level, safety belts must be worn and ropes of sufficient strength must be securely fastened to the outdoor unit to prevent falling that could cause personal injury or death as well as property loss.

Safety Principles for Installing Air Conditioner

- Fire prevention device shall be prepared before installation.
- Keep installing site ventilated.(open the door and window)
- Do not allow any ignition sources, smoking, or phone calls in areas where R32 refrigerant is present.
- Anti-static precautions in necessary for installing air conditioner, e.g. wear pure cotton clothes and gloves.
- Ensure the leak detector is operational during the installation.
- If R32 refrigerant leakage occurs during the installation, you shall immediately detect the concentration in indoor environment until it reaches a safe level.
- If refrigerant leakage affects the performance of the air conditioner, please immediately stop the operation, and the air conditioner must be vacuumed firstly and be returned to the maintenance station for processing.
- Keep electric appliance, power switch, plug, socket, high temperature heat source and high static away from the area underneath sidelines of the indoor unit.
- The air conditioner shall be installed in an accessible location for installation and maintenance, without obstacles that may block air inlets or outlets of indoor /outdoor units. It shall be kept away from heat source, inflammable or explosive conditions as well.
- When installing or repairing the air conditioner and the connecting line is not long enough, the entire connecting line shall be replaced with the connecting line of the original specification; extension is not allowed.
- When installing an R32 HVAC system, it's crucial to ensure that the installation site meets specific safety requirements due to the flammable nature of R32 refrigerant.

Requirements of the Mounting Structure

- The mounting rack must meet the relevant national or industrial standards.
- It is recommended that the mounting rack and its load carry surface shall be able to withstand 4 times or above the weight of the unit.
- The mounting rack of the outdoor unit shall be fastened with expansion bolts or as recommended by the manufacturer.
- Ensure the secure installation regardless of what type of wall on which it is installed, to prevent potential dropping that could cause damage or injury.

Grounding Requirements

- Be sure to properly ground the unit. Follow all local and national codes as applicable.
- Do not connect the grounding wire to a gas pipe, water pipe, lightning rod, telephone line, or a circuit poorly grounded to the earth.
- The grounding wire is specially designed and shall not be used for other purpose, nor shall it be fastened with a common tapping screw.
- Ensure that all electrical connects are securely fasted and connected to the correct terminals.
- Local and national electrical codes must be utilized.

Others

- The connection method of the air conditioner and the power cable and the interconnection method of each independent element shall be subject to the wiring diagram affixed to the machine.
- The model and rating value of the fuse should match the information printed on the silkscreen of the corresponding controller or the fuse sleeve.

Before Installation

Accessories

Read these Safety Considerations carefully before installing the drain pan heater. After completing the installation, check if the unit operates properly during the start-up operation.

Field-supplied Parts

Name	Quantity	Unit
Electrical wiring	1*N	Set
Connecting pipes	2*N	PC
Plastic Strap	1*N	ROLL
Pipe Protection Ring	1*N	PC
Putty	1*N	PACKET

N: Number of indoor unit

NOTE: Interconnection cord and sound deadening pads is optional accessories.

Tools Required

Name	
Phillips screwdriver	Utility knife or scissors
Clamp on Amp Meter	Hexagonal Wrench
Vacuum Pump	Level
Torque wrench	Hole Saw
Flare tool	Safety Glasses
Refrigerant Scale	Wrench (or spanner)
Manifold and Gauges	Pipe Cutter
Work Gloves	

Installation Of The Outdoor Unit

Outdoor Unit Dimensions

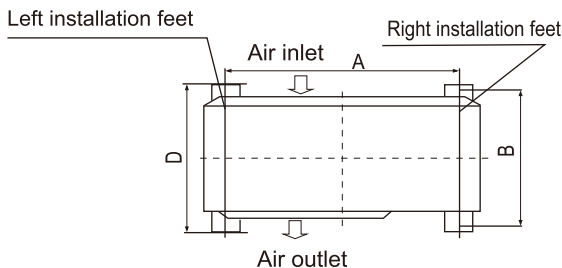
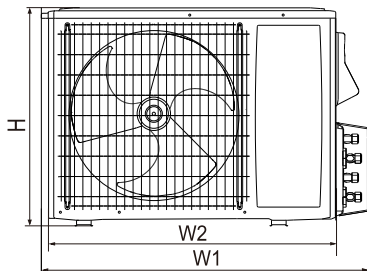

Outdoor Unit Size of Shape W1 (W2)*H*D, in (mm)	A in (mm)	B in (mm)
34.7(31.0)×21.9×13.9 880(787)×557×353	21.5(546)	12.4(316)
38.6(35.3)×27.6×15.3 980(897)×700×388	24.9(632)	13.9(352)

Attention to Installation Site

CAUTION



- The installation place must be well-ventilated, so that the unit can move enough air to operate correctly.
- The installation place must be enough firm to support the weight of outdoor unit and can also reduce noise and vibration.
- Avoid direct sunlight, and if necessary a sun shelter should be mounted.
- The installation place should allow for the drainage or rainwater and water produced during defrosting.
- The installation place should prevent the unit from getting buried in a snowdrift.
- The unit should not be installed so that the fan blows into strong winds.
- Ensure that neither the air from the outdoor unit nor noise produced by it will affect the neighbours.
- The unit must not be in a position where people will pile rubbish on top of it or where it will be affected by exhaust gases.
- In order to ensure the use effect, the external machine is not allowed to be installed in the basement or other closed rooms.

Where you install the outdoor unit will have a direct effect upon its performance.

- In order for the outdoor unit to operate at its best you should carefully follow these instructions. In particular it's important to prevent discharge air from returning to the rear of the unit. This should be avoided as this will significantly reduce the cooling and heating performance.
- The discharge air which is expelled from the front of the unit should not be allowed to immediately enter the return inlet of the back of the unit.
- Ensure there is ample space in front of the unit; this will help prevent this from happening.
- Ensure the unit is installed on a level surface and that there is plenty of room to service the equipment. Do not allow a slope of more than 5°.

The following figures show the right installation and wrong installation:

Installation Of The Outdoor Unit

ENGLISH

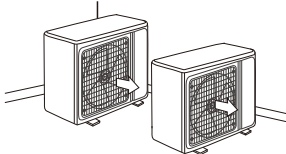
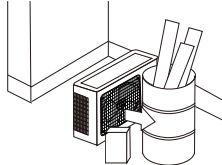
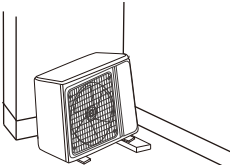
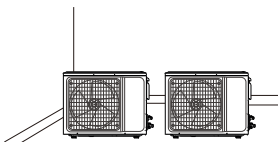
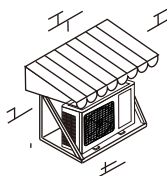
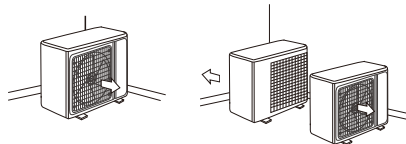
Wrong installation		
		⊗
		⊗
		⊗
Right installation		
		⊙
		⊙
		⊙

Installation Guide at the Seaside

- Air conditioners should not be installed in areas where corrosive gases, such as acid alkaline gas, are produced.
- Do not install the product where it could be exposed to direct salt air. Sea air exposure can result in corrosion on the unit. Corrosion, particularly on the condenser and evaporator fins, could cause product malfunction, inefficient performance, and refrigerant leaks.
- If the outdoor unit is installed close to the seaside, it should avoid direct exposure to the sea wind. Otherwise, it may need additional anticorrosion treatment.
- The windbreak should be strong enough like concrete to prevent the sea wind from hitting the unit. The height and width should be more than 150% of the outdoor unit.
- Select a well-drained place. Install the outdoor unit on the opposite side of the direction of the sea wind, or set up a windbreak to avoid exposed to the sea wind. Seaside applications will require more frequent maintenance checks and cleaning. Be sure to keep the system free of salt build up by washing the unit with clean water at low pressure.

- The unit should be kept more than 27-9/16in.(70cm) from the windbreak for easy air flow.
- The mounting rack of the outdoor unit shall be fastened with expansion bolts or as the manufacture recommends.
- If installing on a wall, ensure the secure installation regardless of the type of to prevent potential dropping that could damage the unit or cause injury.

Unit: in.(cm)

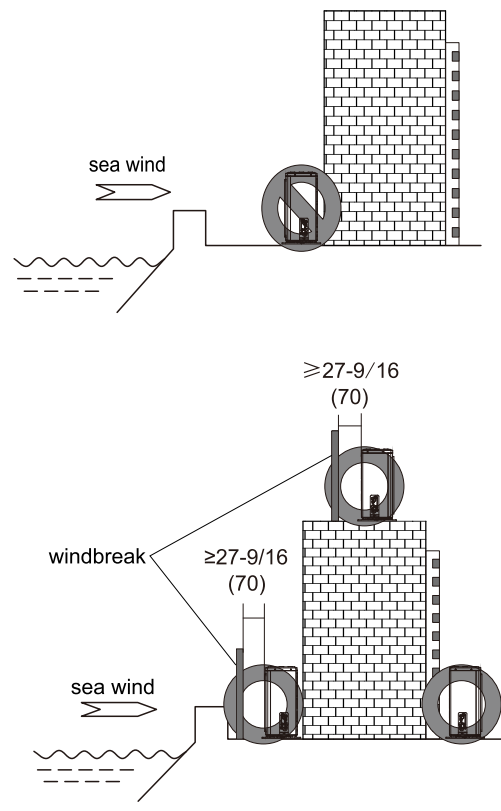

Correct installation

- Caution :**
- When unpacking, open the carton, please remove the packing foam first, then take out the air conditioner.
- Do not touch the heat exchanger at the rear of the indoor unit with your hands or any other object!
 - Handling with the handle and side angle, please handle with care, Do not drop the unit or allow it to fall during transport.
 - When the outdoor unit is to be lifted, please use two slings longer than 26-1/4ft (8m) and insert cushioning material between the slings and outdoor unit to avoid damaging the casing.

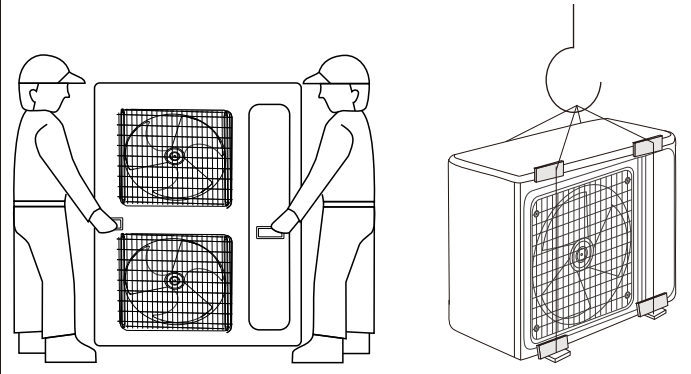

Installation Of The Outdoor Unit

Installation Drawing

This installation chart is for reference only

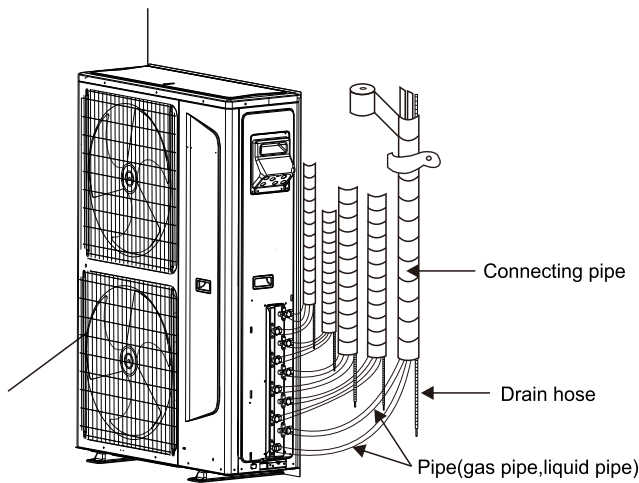
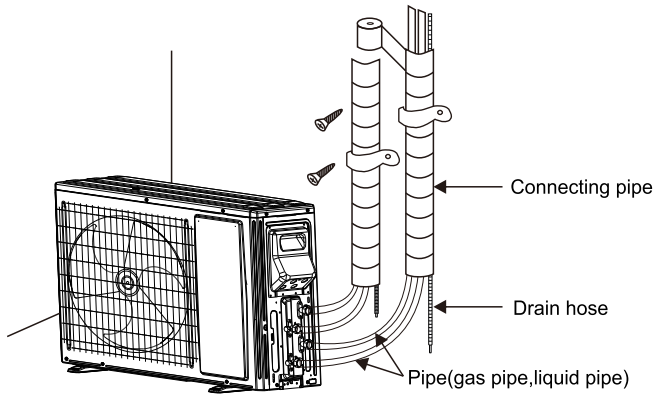

Select Installation Site

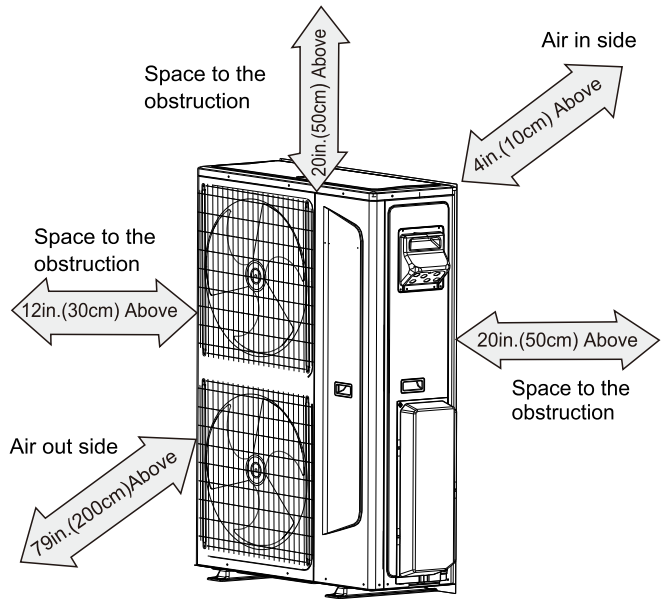
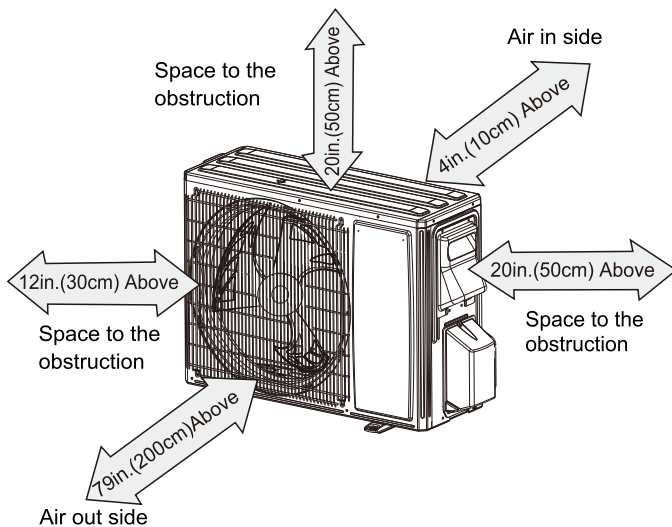

CAUTION

- Install a drainage channel to allow the condensate to flow smoothly away.
- During installation please ensure that the foundations are secure and level to avoid vibration and noise
- Please bolt (M8 or M10) the outdoor unit down securely.
- The bolts for connecting the outdoor unit should protrude 13/16in. (20mm) above the surface of the base.
- Do not just use the four corners as a foundation to support the unit.

Unit: in.(mm)

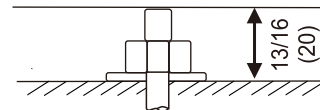

Outdoor Condensation Drainage

Heat pump type only

When the unit is in heating mode, the outdoor unit can generate water that will drip from the bottom of the unit. To control the flow of that water, please use the provided drain elbow.

Installation:

- Install the drain elbow in the 1in. (Φ 25mm) hole on the bottom of the base plate, and connect the drain hose to the elbow. Route the hose to a location so that the water formed in the outdoor unit can be drained out to a proper location.
- In cold areas, do not use a the drain elbow or drain plugs on the outdoor unit. Plugging the holes will cause ice to buildup in the base pan which could result in damage to the unit. In cold climates, make sure the unit has plenty of space to drain and avoid snow drifts.
- The pipe should be installed with a downward gradient (>1/1.36) to allow the water to drain away.
- The pipe should not rise at any point.

Installation Of The Outdoor Unit

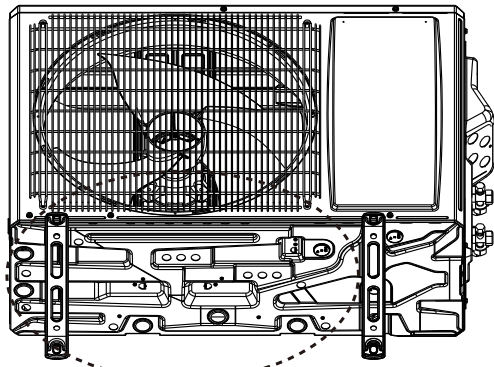

Air outlet side

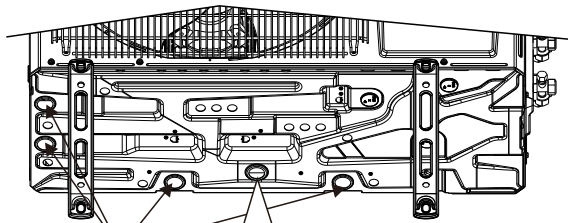

Drain plug

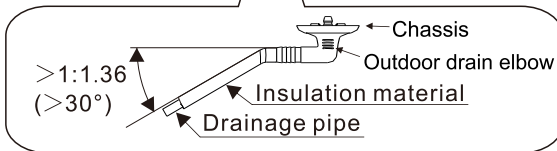

Piping Works and Flaring Techniques

- Do not use contaminated or damaged copper tubing. If the evaporator, condenser, or any piping has been open and exposed to the atmosphere for 15 seconds or more, the system must be vacuumed. Do not remove plastic plugs or brass nuts from piping connections until the connections are ready to be made.
- If any brazing work is required, ensure that a nitrogen gas purge is utilized to prevent soot formation on the inside wall of copper tubing. Failure to do so may cause damage to the unit and void warranty.
- Cut the pipe as straight as possible (See Fig. 1). Make sure to use a deburring tool to remove any burrs. Hold the pipe with opening facing down to prevent metal chips from entering the pipe (See Fig. 2).
- This will avoid unevenness on the flare faces which will cause gas leak.
- Insert the flare nuts, mounted on the connection parts of both the indoor unit and outdoor unit, into the copper pipes.
- The exact length of pipe protruding from the top surface of the swaging block is determined by the flaring tool. (See Fig. 3)
- Fix the pipe firmly on the swaging block. Match the centers of both the swaging block and the flaring punch, then tighten the flaring punch fully.
- The refrigerant pipe connection are insulated by closed cell polyurethane.

Fig. 1

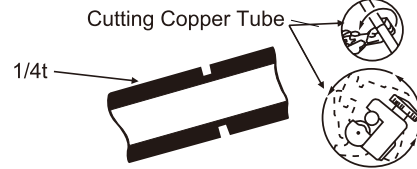

Fig. 2

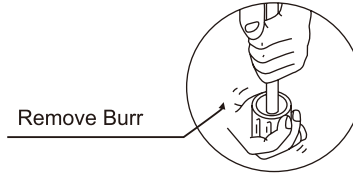
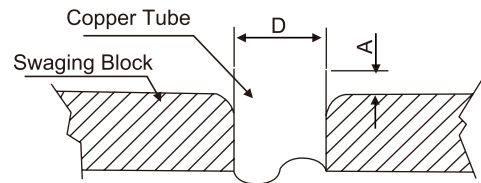

Fig. 3



Ø Tube, D	A(Inch/mm)		
	Inch	mm	Imperial (Wing-nut Type) / Rigid (Clutch Type)
1/4		6.35	0.051" (1.3) / 0.028" (0.7)
3/8		9.52	0.063" (16) / 0.039" (10)
1/2		12.70	0.075" (19) / 0.051" (13)
5/8		15.88	0.087" (2.2) / 0.067" (1.7)
3/4		19.05	0.098" (2.5) / 0.079" (2.0)

Install The Connection Pipe

Connect the pipe to the unit
Align the center of the piping and tighten the flare nut sufficiently with fingers. (See Fig. 4)
Finally, tighten the flare nut with torque wrench until the wrench clicks.
When tightening the flare nut with the torque wrench, ensure that the tightening direction follows the arrow indicated on the wrench.
The refrigerant pipe connection are insulated by closed cell polyurethane.

Tightening torque table

The size of pipe, in.(mm)	Torque, ft-lb(N·m)
Ø1/4 (Ø6.35)	11.0-18.4 (15-25)
Ø3/8 (Ø9.52)	25.8-29.5 (35-40)
Ø1/2 (Ø12.7)	33.2-44.3 (45-60)
Ø5/8 (Ø15.88)	53.9-57.6 (73-78)
Ø3/4 (Ø19.05)	55.3-59.0 (75-80)

Installation Of The Outdoor Unit

Fig. 4

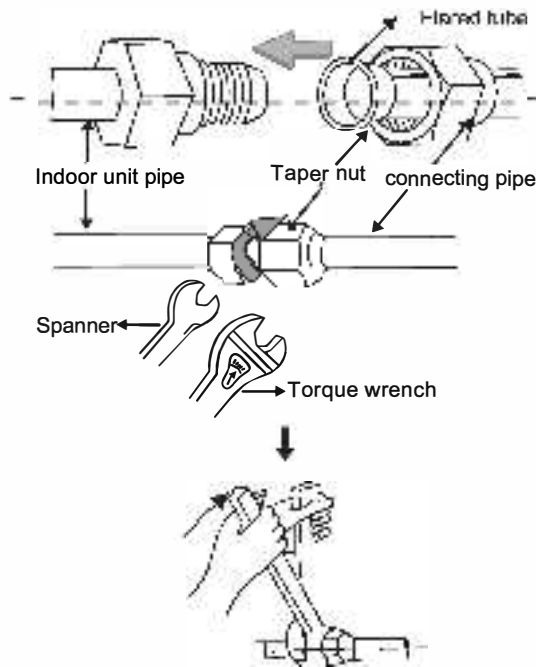

Note:

- Carefully check if there is any damage of joints before installation.
- The joints shall not be reused, unless after re-flaring the pipe.
- When the length of the connecting pipe is changed, extra amount of refrigerant need to be added, so that the operation and performance of the air conditioner will not be compromised.
- After installation, check the stop valve cover whether be fixed effectively.
- Wrap up all pipe, water discharge and connection wire from top to below.
- Cover the connection and fix them with two plastic rings.

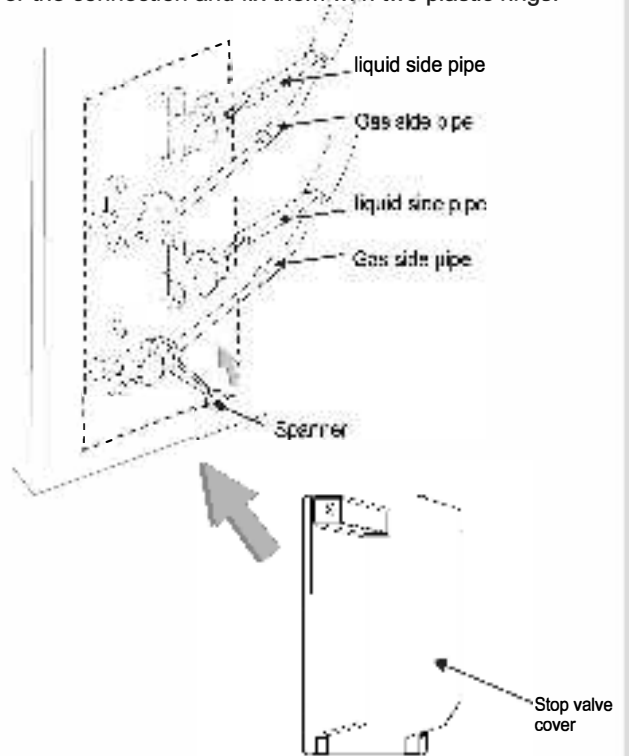

When the adapter is required for the connection of indoor unit and outdoor unit ,the method of pipe connection as follows :

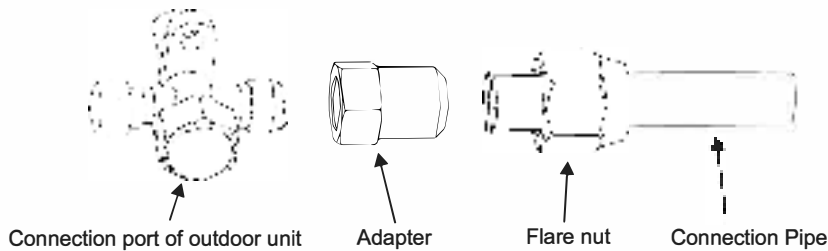

The size of adapters ,inch(mm)	
①	Ø3/8" (Ø9.52) → Ø1/2" (Ø12.7)
②	Ø3/8" (Ø9.52) → Ø5/8" (Ø15.88)

The line set piping size is determined by the size of the indoor unit fittings. Use the adapter supplied with the unit as described below.

The indoor unit models	The size of adapters	Quantity
09K/12K	No need	Number of indoor unit
18K	①	

Installation Of The Outdoor Unit

Selection of the installing position

You can adjust the vertical location of indoor and outdoor units according to the installation requirement. If the outdoor unit is installed higher than indoor units and $H_1, H_2, H_3 > 23.0 \text{ ft (7m)}$, please set the oil bend every 9.84 ft (3m) on the vertical gas pipe. In other cases don't need to install oil bend.

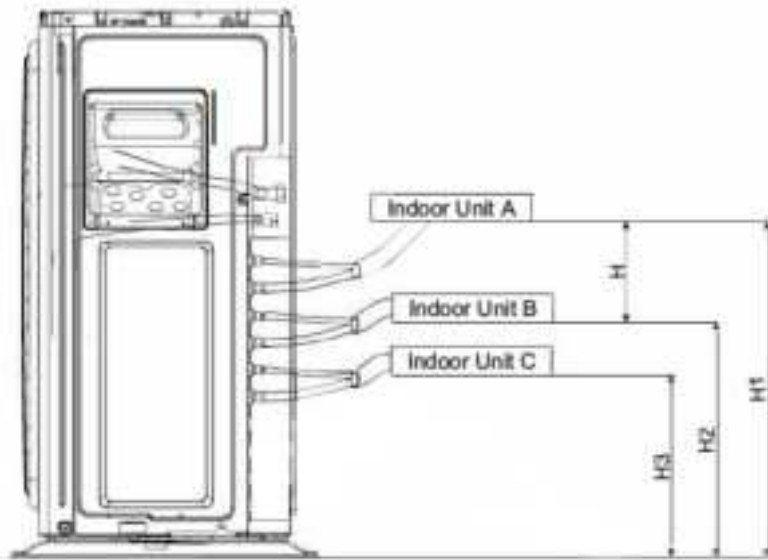

Pipe length and height difference

Series		18K	24K
Pipe size	Liquid pipe size in(mm)	Ø1/4" (Ø6.35)	
	Gas pipe size in(mm)	Ø3/8" (Ø9.52)	
Connecting pipe length	Min.length for 1unit (ft)(m)	16(5)	16(5)
	Max.length for 1unit (ft)(m)	82(25)	98(30)
	Max.pipe length of all indoor unit (ft)(m)	$L_1+L_2 \leq 131(40)$	$L_1+L_2+L_3 \leq 197(60)$
	Max.height difference between indoor units (ft)(m)	33(10)	33(10)
	Max.height difference between indoor and outdoor unit (ft)(m)	49(15)	49(15)
Refrigerant to be added	Average liquid pipe length of indoor units less than (24.6ft) (7.5m)	No refrigerant is required	
	Average liquid pipe length of indoor units more than (24.6ft)(7.5m)	0.16oz/ft(15g/m)	
		0.16oz/ft(Total liquid pipe length-7.5*N) N: Number of indoor unit	

Installation Of The Outdoor Unit

Expelling the air in the pipes and the indoor unit

R32 refrigerant must use a vacuum pump to perform the vacuumizing process. Do not use refrigerant gas to discharge air. Choose Method A or B according to the actual situation of the outdoor unit.

Method A:

1. Connect the pipes of indoor units and outdoor unit according to the figure below, and tighten all the bell coupling nuts of indoor and outdoor to prevent leakage.
2. Connect the cut-off valves, charge hose, manifold valve, vacuum pump as the figure below.
3. Please fully open the manifold valve handle Lo and Hi, and do the vacuum processing, vacuum should be running more than 15 minutes, make sure the vacuum gauge indicates the pressure has reached -14.7psi (-76cmHg);
4. After completion of vacuum processing, use the hex wrench to open a little the liquid valve of unit A and unit B, and then quickly remove the hose of gas valve (remove the hose to prevent air from entering the system);
5. Open all the cut-off valve and check the connecting mouth of indoor and outdoor, then cover the cut-off valves after confirm there is no leak.

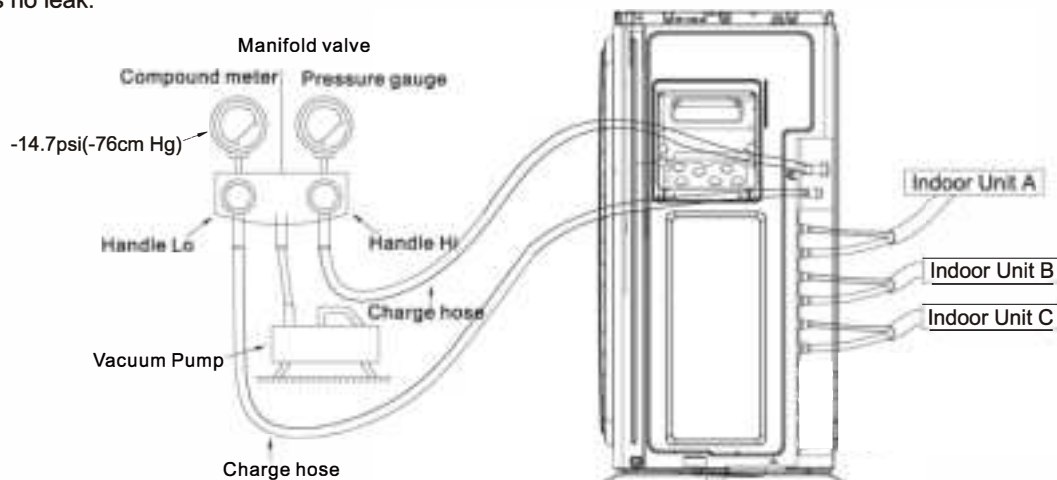

Method B:

Before working on the air conditioner, remove the cover of the stop valve (gas and liquid valves, be sure to retighten it afterward to prevent the potential air leakage).

1. To prevent air leakage, make sure all flares are properly connected and torqued.
2. Connect the stop valve, charge hose, manifold valve, and vacuum pump to the unit.
3. Fully open the handle of the manifold valve and apply vacuum for at least 15 minutes and check that the compound vacuum gauge reads -14.7psi (-76cmHg).
4. After applying vacuum, fully open the stop valve with a hex wrench.
5. Check that both indoor and outdoor connections are free of air leakage.

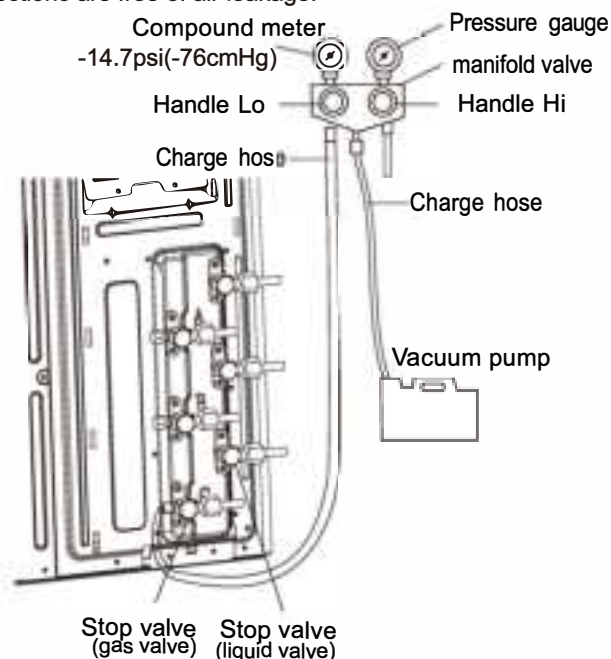

Electrical Connections

Electrical Safety Requirements

- Be sure to use the correct rated voltage for the air conditioner and a dedicated circuit for the power supply,
- Follow local and national codes for the correct power cable AWG.
- The operating range is 90%-110% of the local rated voltage. But insufficient power supply malfunction, electrical shock, or fire. If the voltage instability, proposed to increase the voltage regulator.
- The minimum clearance between the air conditioner and the combustibles is 4-15/16ft (1.5m) or greater.
- Use the correct wire size and type for connecting the indoor unit to the outdoor unit.
- The size of the interconnection cord, power cable, fuse, and switch needed is determined by the maximum current of the unit.
- The maximum current is indicated on the nameplate located on the side panel of the unit. Refer to this nameplate to choose the right wire size, breaker, or switch.
- All electrical works must be carried out & checked by a qualified electrician and must adhere to the IET regulations, local and national legislation and industry best practice. The system must have its own independent power supply.
- Do not attempt any electrical works yourself.
- An Earth Leakage Protector, Power Switch and Circuit Breaker or Fuse must be installed in the dedicated power supply or there is the risk of electric shock.
- The grounding must be reliable. If grounding is not correct, it may lead to electric shock.
- All power cables should be properly secured with cable ties so that external forces can not disconnect the wired from the terminals. Improper connections or insecure fastening can cause electric shocks or fire.

CAUTION

- Do not connect the earth cable to gas or water pipes, telephone lines, lightning rods or the earth cables of other products.
- Once the indoor and outdoor unit have been switched on, do not cut off power off power supply in 1 minute, (the system automatically set) otherwise abnormal operation will be caused.
- Please connect the power cord and interconnecting cable according to the wiring diagram.
- Connect the wire firmly to the terminal block using crimps and secure in order to prevent external forces pulling on the wire causing risk of fire or electric shock.
- After the electrical connection is completed, all wires should be prevented from touching other parts such as tubing, compressor etc.

NOTE

- The definition of power cord is the power supply cable from the isolating switch attached to the dedicated power supply to the indoor unit or outdoor unit. Interconnecting cable for the indoor and outdoor unit is the power cable that connects indoor unit and outdoor unit.
- Above-mentioned definitions are the specifications of power supply, power cord and interconnecting cable of indoor unit and outdoor unit of all different types of air conditioners.
- To avoid voltage drops, when the cross sectional area of a power cable core reaches the minimum size, and the power cord is lengthened, you should choose another bigger power cable size.

Selection of Electrical Parts

The wiring cable specification that is needed in the installation:
(Recommended specifications)

Type	Model	Power line (AWG)	Power connection line(AWG)	Switch/fuse nominal value(A)	Certification Type
Regular	18K	3*14	4*18	20	UL
	24K	3*12			

Wiring Connection

- Open the outdoor unit electrical access panel and connect cables according to the circuit diagram on the backside of the access panel. And check all cables are connected safely, securely and correctly. Earth wire must be connected at the right location
1. Loosen the screws and remove E-parts cover from the unit.
 2. Connect the cables respectively to the corresponding terminals of the terminal board of the outdoor unit (see the wiring diagram), and if there are signals connected to the plug, just conduct butt joint.
 3. Ground wire: Remove the grounding screw out of the electric bracket, cover the grounding wire end onto the grounding screw and screw it into the grounding hole.
 4. Fix the cable reliably with fasteners.
 5. Put the E-parts cover back in its original place and fasten it with screws.

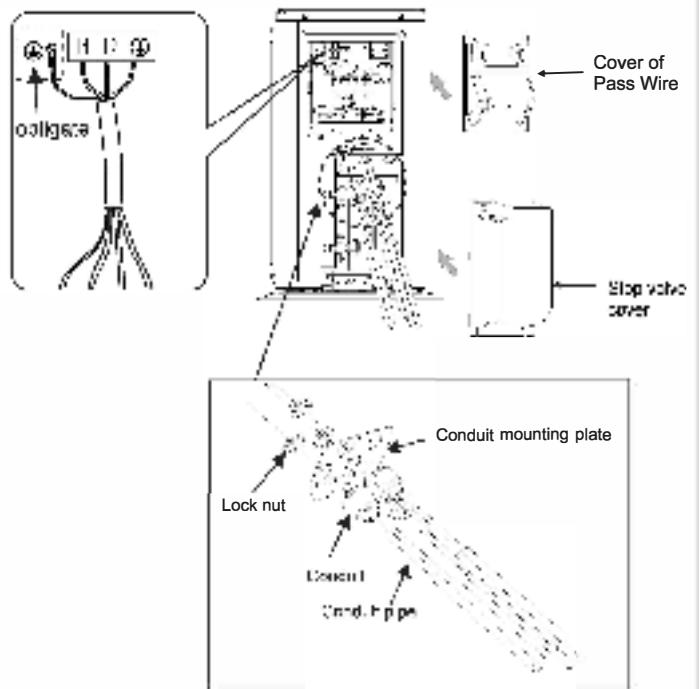

Electrical Connections

Connection wire between indoor and outdoor

The outdoor unit has three(AM2) terminal boards, they are connected to power supply, the indoor unit A, the indoor unit B, the indoor unit C.

Specific connection method as shown below:

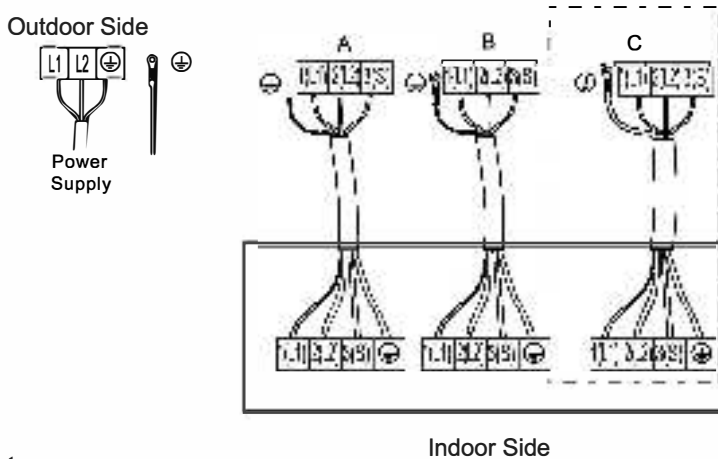

Note:

- The connection wire of indoor units should be connected to the corresponding terminal board, that is the power core of A can't connected to the outdoor terminal board for B, otherwise it will cause the unit failure or even damage the units.
- Make sure to connect correct piping and wiring to correct room.
- The PC board of outdoor unit whose power supply has phase sequence protection. Please pay attentions to it while connecting powercable.

Testing And Inspection

Check after Installation

●Electrical Safety Check

1. If the supply voltage is within tolerance.
2. If the indoor and outdoor units are properly wired.
3. If the grounding wire of the air conditioner is securely grounded.

●Installation Safety Check

- 1.If the unit is mounted properly and securely.
- 2.If the water drains smoothly from indoor unit to outdoor drain.
- 3.If the wiring and piping are correctly installed and free of leaks
- 4.Check that no foreign matter or tools are left inside the unit.
- 5.Check the refrigerant pipeline and connections are properly insulated.

●Leak test of the refrigerant

Depending on the installation method, the following methods may be used to check for suspect leak, on areas such as the connections of the outdoor unit and the cores of the cut-off valves and t-valves:

- 1.Bubble method: Apply of spray a uniform layer of soap water over the suspected leak spot and observe carefully for bubble.
- 2.Instrument method: Checking for leak by pointing the probe of the leak detector according to the instruction to the suspect points of leak.

Note:

Make sure that the ventilation is good before checking.

Test Operation

●Test Operation preparation:

1. Verify that all piping and wiring is properly connected.
2. Confirm that the valve at the gas side and the liquid-side are fully open.
3. Verify that power is turned on to the unit.
4. Install batteries in the remote control.

Note:

Make sure that the ventilation is good before testing.

●Test Operation method:

- 1.Turn on the power and push the ON/OFF switch button of the remote controller to start the air conditioner.
- 2.Select COOL or HEAT, adjust the SWING and other operation modes with the remote controller to verify proper operation.

Fault Code

Check the following before requesting on service centre of if the malfunction occurs.

Phenomenon	Troubleshooting																														
Air conditioner dose not operate at all	<ul style="list-style-type: none"> • Has the power been shut down? • Is the wiring loose? • Is the voltage higher than 1.1 times of max rated voltage or lower than 0.9 times of min rated voltage? • Is the fuse burnt? • Does it reach the set time for start up? 																														
Remote controller is not available	<ul style="list-style-type: none"> • Is the remote controller out of effective distance to the indoor unit? • Is the battery exhausted? • Are there any obstructions between the controller and the signal receptor? 																														
Cooling (Heating)efficiency is not good	<ul style="list-style-type: none"> • Is the setting temperature suitable? • Is the air inlet or outlet obstructed? • Are air filter dirty? • Is indoor fan speed set at low speed? • Is there any heat source in your room? 																														
Indoor unit does not operate immediatly when the air conditioner is restarted	Once the air conditioner is stopped, it will not operate in approximately 3 minutes to protect itself.																														
There is unusual smell blowing from the outlet after operation is started	This is caused by the odour in the room permeated from building material, furniture,or smoke.																														
Sound of water flow can be heard during cooling operation	This is caused by the refrigerant flowing insidethe unit.																														
Mist is emitted during cooling operation.	Because the air of the room is cooleddown rapidly by the cold wind and it looks likethe fog.																														
Mist is emitted during heating operation.	This generate due to moisture in defrosting process																														
A low hissing sound is caused by the refrigerant flowing.	<ul style="list-style-type: none"> • Low noise can be heard during operation • A low squeak sound is caused by the deformation of plastic due to temperature. 																														
<p>Mode interfere</p> <p>For the reason that all indoor units use one outdoor unit, outdoor unit can only run with same model cooling or heating),so,when the mode you set is different from the mode, that outdoor is running with, mode interfere occurs. Following shows the mode interfere scene.</p>	<table border="1"> <thead> <tr> <th></th> <th>cooling</th> <th>dry</th> <th>heating</th> <th>fan</th> <th></th> </tr> </thead> <tbody> <tr> <td>cooling</td> <td>√</td> <td>√</td> <td>×</td> <td>×</td> <td>√ --normal</td> </tr> <tr> <td>dry</td> <td>√</td> <td>√</td> <td>×</td> <td>×</td> <td>×</td> </tr> <tr> <td>heating</td> <td>×</td> <td>×</td> <td>√</td> <td>√</td> <td>×</td> </tr> <tr> <td>fan</td> <td>√</td> <td>√</td> <td>√</td> <td>√</td> <td>×</td> </tr> </tbody> </table> <p>outdoor unit always run with the mode of first indoor unit that turned on. When the setting mode of following indoor unit is interfere with it,3 beeps would be heard, and the indoor unit interfered with the normal running units would turn off automatically</p>		cooling	dry	heating	fan		cooling	√	√	×	×	√ --normal	dry	√	√	×	×	×	heating	×	×	√	√	×	fan	√	√	√	√	×
	cooling	dry	heating	fan																											
cooling	√	√	×	×	√ --normal																										
dry	√	√	×	×	×																										
heating	×	×	√	√	×																										
fan	√	√	√	√	×																										

ENGLISH

Fault Code

When the air conditioner fails, the LED light or digital tube on indoor display board will show the corresponding fault code according to different fault. For the unit with digital tube, it will show the corresponding fault codes; for the unit no digital tube only LED light, it will only show the corresponding fault codes with timer light.

Specific correspond is as follows:

Compact Cassette/Ceiling&Floor/Slim Duct/Console

Fault code	Fault description	Causes of possible failure
A1	Fault with the room temperature sensor on the N # indoor unit	<ul style="list-style-type: none"> ● Damage of the room temperature sensor on the indoor unit ● Poor contact of the room temperature sensor on the indoor unit ● Damage of wiring of the room temperature sensor on the indoor unit ● Damage of the main PCB on the indoor unit
A2	Fault with the temperature sensor in the Middle of N # indoor evaporator	<ul style="list-style-type: none"> ● Damage of the temperature sensor on the indoor unit ● Poor contact of the temperature sensor on the indoor unit ● Damage of wiring of the temperature sensor on the indoor unit ● Damage of the main PCB on the indoor unit
A3	Fault of temperature sensor at N# evaporator inlet	<ul style="list-style-type: none"> ● Damage of temperature sensor at N # evaporator inlet ● Poor contact of temperature sensor at N # evaporator inlet ● Damage of wiring of temperature sensor at N # evaporator inlet ● Damage of the main PCB on the outdoor unit
A4	Fault of temperature sensor at N# evaporator outlet	<ul style="list-style-type: none"> ● Damage of temperature sensor at N# evaporator outlet ● Poor contact of temperature sensor at N# evaporator outlet ● Damage of wiring of temperature sensor at N# evaporator outlet ● Damage of the main PCB on the outdoor unit
A5	Fault with the drainage on N# indoor unit	<ul style="list-style-type: none"> ● Float switch disconnected or poor wiring ● Error setting of model parameters ● Drain plug ● Damage of the pump
A6	Fault with the Fan motor of N# indoor unit	<ul style="list-style-type: none"> ● Low voltage ● Poor wiring ● Damage of the main PCB on the indoor unit ● Damage of the motor
A9	Communication error between the outdoor unit and the N # indoor unit	<ul style="list-style-type: none"> ● Damage of the main PCB on the indoor unit ● Damage of the main PCB on the outdoor unit ● Poor wiring
AA	Communication error between the wired controller and main PCB of the indoor unit	<ul style="list-style-type: none"> ● Damage of the main PCB on the indoor unit ● Damage of the display board on the indoor unit ● Poor wiring
H1	High Pressure Switch Protection	<ul style="list-style-type: none"> ● system dirty blocking ● Damage of High Pressure Switch
H4	Low pressure switch protection	<ul style="list-style-type: none"> ● Lack of the refrigerant ● Stop valve unopened ● Damage of low pressure switch
C1	Fault with the Environmental temperature sensor on the outdoor unit	<ul style="list-style-type: none"> ● Damage of the Environmental temperature sensor on the outdoor unit ● Poor contact of the Environmental temperature sensor on the outdoor unit ● Damage of wiring of the Environmental temperature sensor on the outdoor unit ● Damage of the main PCB on the outdoor unit
C2	Fault with the defrosting temperature sensor on the outdoor unit	<ul style="list-style-type: none"> ● Damage of the defrosting temperature sensor on the outdoor unit ● Poor contact of the defrosting temperature sensor on the outdoor unit ● Damage of wiring of the defrosting temperature sensor on the outdoor unit ● Damage of the main PCB on the outdoor unit
C3	Fault with the discharge temperature sensor	<ul style="list-style-type: none"> ● Damage of the discharge temperature sensor on the outdoor unit ● Poor contact of the defrosting temperature sensor on the outdoor unit ● Damage of wiring of the defrosting temperature sensor on the outdoor unit ● Damage of the main PCB on the outdoor unit
C6	Fault with the suction temperature sensor	<ul style="list-style-type: none"> ● Damage of the suction temperature sensor on the outdoor unit ● Poor contact of the suction temperature sensor on the outdoor unit ● Damage of wiring of the suction temperature sensor on the outdoor unit ● Damage of the main PCB on the outdoor unit

Fault Code

Fault code	Fault description	Causes of possible failure
C8	Fault with the temperature Sensor in the Middle of outdoor condenser	<ul style="list-style-type: none"> • Damage of the temperature sensor on the outdoor unit • Poor contact of the temperature sensor on the outdoor unit • Damage of wiring of the temperature sensor on the outdoor unit • Damage of the main PCB on the outdoor unit
J3	Communication error between the driver PCB and main PCB of the outdoor unit	<ul style="list-style-type: none"> • Damage of the driver PCB on the outdoor unit • Damage of the main PCB on the outdoor unit • Poor wiring
J7	Fault with the outdoor unit EEPROM	<ul style="list-style-type: none"> • Fault with the EE chip on the outdoor unit PCB
E1	Fault of four way valve	<ul style="list-style-type: none"> • Damage of four-way valve • Damage to coil of four-way valve
E3	Protection high temperature discharge	<ul style="list-style-type: none"> • Lack of the refrigerant • Stop valve unopened • Damage of the main PCB on the outdoor unit
E8	High Temperature Protection for Refrigeration Outdoor	<ul style="list-style-type: none"> • Poor outdoor heat transfer
F6	Low pressure protection	<ul style="list-style-type: none"> • Lack of the refrigerant • Heat exchange viscera
FH	Protection lower temperature discharge	<ul style="list-style-type: none"> • Temperature sensor shedding • Damage of the main PCB on the outdoor unit
31	Module protection failure	<ul style="list-style-type: none"> • Compressor damage • Compressor IPM Module damage • System blockage
32	Fault with the driver EEPROM	<ul style="list-style-type: none"> • Damage of the EE chip of driver board
34	Compressor protection failure	<ul style="list-style-type: none"> • Compressor power line not connected • Compressor sequence connection error • Damage of compressor • System blockage
35	AC Over-current Protection of the Whole Machine	<ul style="list-style-type: none"> • Excessive running current of the unit • Voltage drops abruptly during operation
36	Fault with the over-voltage or low voltage protection	<ul style="list-style-type: none"> • Excessive input voltage • Lower input voltage
39	IPM Temperature sensor faulte	<ul style="list-style-type: none"> • Compressor IPM Module sensor damage • Poor contact between compressor IPM module and radiator
3H	Fault with the Fan motor of outdoor unit	<ul style="list-style-type: none"> • Damage of motor
3C	Outdoor DC Fan motor over current protection	<ul style="list-style-type: none"> • The current of the outdoor DC fan motor is too large
3J	Overvoltage protection of outdoor DC fan motor	<ul style="list-style-type: none"> • The voltage of the outdoor DC fan is too large or too small
3E	Compressor drive PFC software protection	<ul style="list-style-type: none"> • Damage of the PFC circuit components • Reactor damage
3F	Compressor drive PFC hardware protection	<ul style="list-style-type: none"> • Damage of the PFC circuit components • Reactor damage
41	IPM Protection of Outdoor DC Fan	<ul style="list-style-type: none"> • The IPM Device of DC Motor is Bad
AD	Indoor anti-freezing pratection	<ul style="list-style-type: none"> • Dirty Blockage of Heat Exchanger in Refrigeration Indoor Unit Blockage of Internal Fan

Fault Code

Wall Mounted

Fault code	Fault description	Causes of possible failure
E1	Fault with the room temperature sensor on the N # indoor unit	<ul style="list-style-type: none"> ● Damage of the room temperature sensor on the indoor unit ● Poor contact of the room temperature sensor on the indoor unit ● Damage of wiring of the room temperature sensor on the indoor unit ● Damage of the main PCB on the indoor unit
E2	Fault with the Defrosting condenser Temperature Sensor in outdoor	<ul style="list-style-type: none"> ● Damage of the temperature sensor on the outdoor unit ● Poor contact of the temperature sensor on the outdoor unit ● Damage of wiring of the temperature sensor on the outdoor unit ● Damage of the main PCB on the outdoor unit
E3	Fault with the temperature sensor in the Middle of N # indoor evaporator	<ul style="list-style-type: none"> ● Damage of the temperature sensor on the indoor unit ● Poor contact of the temperature sensor on the indoor unit ● Damage of wiring of the temperature sensor on the indoor unit ● Damage of the main PCB on the indoor unit
E4	Fault with the Fan motor of N # indoor unit	<ul style="list-style-type: none"> ● Low voltage ● Poor wiring ● Damage of the main PCB on the indoor unit ● Damage of the motor
E5	Communication error between the outdoor unit and the N# indoor unit	<ul style="list-style-type: none"> ● Damage of the main PCB on the indoor unit ● Damage of the main PCB on the outdoor unit ● Poor wiring
E8	communication error between the display board and main PCB of the indoor unit	<ul style="list-style-type: none"> ● Damage of the main PCB on the indoor unit ● Damage of the main PCB on the outdoor unit ● Poor wiring
F0	Fault with the Fan motor of outdoor unit	<ul style="list-style-type: none"> ● Damage of motor
F1	Module protection failure	<ul style="list-style-type: none"> ● Compressor damage ● Compressor IPM Module damage ● System blockage
F2	Compressor drive PFC protection	<ul style="list-style-type: none"> ● Damage of the PFC circuit components ● Reactor damage
F3	Compressor protection failure	<ul style="list-style-type: none"> ● Compressor power line not connected ● Compressor sequence connection error ● Damage of compressor ● System blockage
F4	Fault with the discharge temperature sensor	<ul style="list-style-type: none"> ● Damage of the discharge temperature sensor on the outdoor unit ● Poor contact of the discharge temperature sensor on the outdoor unit ● Damage of wiring of the discharge temperature sensor on the outdoor unit ● Damage of the main PCB on the outdoor unit
F5	Temperature protection of compressor top cover	<ul style="list-style-type: none"> ● Damage of compressor top cover switch ● System blockage
F6	Fault with the Environmental temperature sensor on the outdoor unit	<ul style="list-style-type: none"> ● Damage of the Environmental temperature sensor on the outdoor unit ● Poor contact of the Environmental temperature sensor on the outdoor unit ● Damage of wiring of the discharge temperature sensor on the outdoor unit ● Damage of the main PCB on the outdoor unit
F7	Fault with the over-voltage or low voltage protection	<ul style="list-style-type: none"> ● Excessive input voltage ● Lower input voltage
F8	Communication error between the driver PCB and main PCB of the outdoor unit	<ul style="list-style-type: none"> ● Damage of the driver PCB on the outdoor unit ● Damage of the main PCB on the outdoor unit ● Poor wiring
F9	Fault with the outdoor unit EEPROM	<ul style="list-style-type: none"> ● Chip damage

Fault Code

Fault code	Fault description	Causes of possible failure
FA	Fault with the suction temperature sensor	<ul style="list-style-type: none"> • Damage of the suction temperature sensor on the outdoor unit • Poor contact of the suction temperature sensor on the outdoor unit • Damage of wiring of the suction temperature sensor on the outdoor unit • Damage of the main PCB on the outdoor unit
H1	Fault with the drainage on N# Indoor unit	<ul style="list-style-type: none"> • Float switch disconnected or poor wiring • Error setting of model parameters • Drain plug • Damage of the pump
H2	communication error between the wired controller and main PCB of the N# indoor unit	<ul style="list-style-type: none"> • Poor wiring • Damage of the wired controller • Damage of the main PCB on the indoor unit
H3	Fault of temperature sensor at N # evaporator inlet	<ul style="list-style-type: none"> • Damage of temperature sensor at N # evaporator inlet • Poor contact of temperature sensor at N# evaporator inlet • Damage of temperature sensor at N# evaporator inlet • Damage of the main PCB on the outdoor unit
H4	Fault of temperature sensor at N# evaporator outlet	<ul style="list-style-type: none"> • Damage of temperature sensor at N# evaporator outlet • Poor contact of temperature sensor at N# evaporator outlet • Damage of wiring of temperature sensor at N evaporator outlet • Damage of the main PCB on the outdoor unit
H5	Protection lower temperature discharge	<ul style="list-style-type: none"> • Temperature sensor shedding • Damage of the main PCB on the outdoor unit
H6	Low pressure switch protection	<ul style="list-style-type: none"> • Lack of the refrigerant • Stop valve unopened • Damage of low pressure switch
H7	Low pressure protection	<ul style="list-style-type: none"> • Lack of the refrigerant • Heat exchanger viscera
H8	Fault of four way valve	<ul style="list-style-type: none"> • Damage of four-way valve • Damage to coil of four-Way valve
H9	Inter-computer communication line connection fault	/
L0	Overvoltage and undervoltage protection of indoor DC motor	<ul style="list-style-type: none"> • Excessive input voltage • Lower input voltage
L1	Overvoltage protection of compressor	<ul style="list-style-type: none"> • Damage of compressor • System viscera
L2	Compressor operation failure	<ul style="list-style-type: none"> • Damage of compressor • System viscera
L3	Phase-absence protection of compressor	<ul style="list-style-type: none"> • Damage of compressor • Compressor power line not connected
L4	IPM Fault of compressor Drive module	<ul style="list-style-type: none"> • Compressor drive module damage
L5	Compressor drive PFC hardware protection	<ul style="list-style-type: none"> • Damage of the PFC circuit components • Reactor damage
L6	Compressor drive PFC software protection	<ul style="list-style-type: none"> • Excessive running current of the unit • Voltage drops abruptly in operation
L7	AD Abnormal protection for compressor current detection	<ul style="list-style-type: none"> • Sensor damage of compressor IPM module
L8	Compressor superpower protection	<ul style="list-style-type: none"> • Sampling resistance damage • Excessive operating power of compressor
L9	IPM Temperature sensor fault	<ul style="list-style-type: none"> • Compressor IPM Module sensor damage • Poor contact between compressor IPM module and radiator

Fault Code

Fault code	Fault description	Causes of possible failure
LA	Compressor start failure	<ul style="list-style-type: none"> ● Compressor power line not connected
LC	PFC Current Detection AD Abnormal Protection	<ul style="list-style-type: none"> ● Failure of PFC Module Circuit Device
LD	AD Abnormal Protection for Outdoor DC Fan Current Detection	<ul style="list-style-type: none"> ● Failure of DC Fan Module Circuit Device
LE	Phase-lacking protection of outdoor DC fans	<ul style="list-style-type: none"> ● DC fan line not connected ● Three wires of DC fan are disconnected
LF	Outdoor DC Fan Out-of-step Protection	<ul style="list-style-type: none"> ● DC motor failure ● High Speed of DC Fan ● System dirty blocking
LH	IPM Protection of Outdoor DC Fan	<ul style="list-style-type: none"> ● The IPM Device of DC Motor is Bad
P2	High Pressure Switch Protection	<ul style="list-style-type: none"> ● System dirty blocking ● Damage of High Pressure Switch
P3	Protection of System Lack of Fluid	<ul style="list-style-type: none"> ● Lack of refrigerant ● Globe Valve Not Opened
P4	High Temperature Protection for Refrigeration Outdoor	<ul style="list-style-type: none"> ● Poor outdoor heat transfer
P5	Protection high temperature discharge	<ul style="list-style-type: none"> ● Lack of the refrigerant ● Stop valve unopened ● Damage of the main PCB on the outdoor unit
P6	High Temperature Protection in heating room	<ul style="list-style-type: none"> ● Poor indoor heat transfer
P7	Indoor anti-freezing protection	<ul style="list-style-type: none"> ● Dirty Blockage of Heat Exchanger in Refrigeration Indoor Unit ● Blockage of Internal Fan
P8	AC Over-current Protection of the Whole Machine	<ul style="list-style-type: none"> ● Excessive running current of the unit ● Voltage drops abruptly in operation
5E	Communication error between the outdoor unit and the indoor unit	<ul style="list-style-type: none"> ● Damage of the main PCB on the indoor unit ● Damage of the main PCB on the outdoor unit ● Poor wiring

Maintenance Notice

Attention:

For maintenance or scrap, please contact a authorized contractor.

Maintenance by unqualified person may cause injury or damage to the unit.

Charge air conditioner with R32 refrigerant only, and maintain the air conditioner in a strict accordance with the manufacturer's requirements.

Qualification of Workers

1. Special training is required to work on equipment with A2L refrigerants. Only rely on qualified contractors to install, service, and repair this system.

2. The maintenance and repair of the air conditioner must be conducted according to the method recommended by the manufacturer.

If other professionals are needed to help maintain and repair the equipment, it should be conducted under the supervision of individuals who have the qualification to repair AC equipped with flammable refrigerants.

Inspection of the Site

Safety inspection must be conducted before maintaining equipment with R32 refrigerant to make sure the risk of fire is minimized.

Check whether the space is well ventilated and whether anti-static or fire prevention equipment is required.

While maintaining the refrigeration system, observe the following precautions before operating the system.

Operating Procedures

1. General work area:

All maintenance staff and others working in the local area shall be instructed on the nature of work being carried out. Work in confined spaces shall be avoided.

2. Checking for presence of refrigerant:

The area shall be checked with an appropriate refrigerant detector prior to and during work, to ensure the technician is aware of potentially toxic or flammable atmospheres. Ensure that the leak detection equipment being used is suitable for use with all applicable refrigerants, i.e. non-sparking, adequately sealed or intrinsically safe.

3. Presence of fire extinguisher:

If any hot work is to be conducted on the refrigerating equipment or any associated parts, appropriate fire extinguishing equipment shall be available to hand. Have a dry powder or CO2 fire extinguisher adjacent to the charging area.

4. No ignition sources:

No person carrying out work in relation to a REFRIGERATING SYSTEM which involves exposing any pipe work shall use any sources of ignition in such a manner that it may lead to the risk of fire or explosion. All possible ignition sources, including cigarette smoking, should be kept sufficiently far away from the site of installation, repairing, removing and disposal, during which refrigerant can possibly be released to the surrounding space. Prior to work taking place, the area around the equipment is to be surveyed to make sure that there are no flammable hazards or ignition risks. "No Smoking" signs shall be displayed.

5. Ventilated Area:

Ensure that the area is in the open or that it is adequately ventilated before breaking into the system or conducting any hot work. A degree of ventilation shall continue during the period that the work is carried out. The ventilation should safely disperse any released refrigerant and preferably expel it externally into the atmosphere.

6. Checks to the refrigeration equipment:

Where electrical components are being changed, they shall be fit for the purpose and to the correct specification. At all times the manufacturer's maintenance and service guidelines shall be followed. If in doubt, consult the manufacturer's technical department for assistance.

The following checks shall be applied to installations using FLAMMABLE REFRIGERANTS:

- The actual REFRIGERANT CHARGE is in accordance with the room size within which the refrigerant containing parts are installed;
- The ventilation machinery and outlets are operating adequately and are not obstructed;
- If an indirect refrigerating circuit is being used, the secondary circuit shall be checked for the presence of refrigerant;
- Marking to the equipment continues to be visible and legible. Markings and signs that are illegible shall be corrected;
- Refrigerating pipe or components are installed in a position where they are unlikely to be exposed to any substance which may corrode refrigerant containing components, unless the components are constructed of materials which are inherently resistant to being corroded or are suitably protected against being so corroded.

7. Checks to electrical devices:

Repair and maintenance to electrical components shall include initial safety checks and component inspection procedures. If a fault exists that could compromise safety, then no electrical supply shall be connected to the circuit until it is satisfactorily dealt with. If the fault cannot be corrected immediately but it is necessary to continue operation, an adequate temporary solution shall be used. This shall be reported to the owner of the equipment so all parties are advised.

Initial safety checks shall include:

- That capacitors are discharged: this shall be done in a safe manner to avoid possibility of sparking;
- That no live electrical components and wiring are exposed while charging, recovering or purging the system;
- That there is continuity of earth bonding.

Repairs to Sealed Components

● During repairs to sealed components, all electrical supplies shall be disconnected from the equipment being worked upon prior to any removal of sealed covers, etc. If it is absolutely necessary to have an electrical supply to equipment during servicing, then a permanently operating form of leak detection shall be located at the most critical point to warn of a potentially hazardous situation.

- Sealed electrical components shall be replaced.

Maintenance Notice

Repair to Intrinsically Safe Components

- Do not apply any permanent inductive or capacitance loads to the circuit without ensuring that this will not exceed the permissible voltage and current permitted for the equipment in use.

- Intrinsically safe components must be replaced.
- Replace components only with parts specified by the manufacturer. Other parts may result in the ignition of refrigerant in the atmosphere from a leak.

NOTE: The use of silicon sealant can inhibit the effectiveness of some types of leak detection equipment. Intrinsically safe components do not have to be isolated prior to working on them.

Cabling

Check that cabling will not be subject to wear, corrosion, excessive pressure, vibration, sharp edges or any other adverse environmental effects. The check shall also take into account the effects of aging or continual vibration from sources such as compressors or fans.

Detection of Flammable Refrigerants

- Under no circumstances shall potential sources of ignition be used in the searching for or detection of refrigerant leaks. A halide torch (or any other detector using a naked flame) shall not be used.

- The following leak detection methods are deemed acceptable for all refrigerant systems.

- Electronic leak detectors may be used to detect refrigerant leaks but, in the case of FLAMMABLE REFRIGERANTS, the sensitivity may not be adequate, or may need re-calibration. (Detection equipment shall be calibrated in a refrigerant-free area.) Ensure that the detector is not a potential source of ignition and is suitable for the refrigerant used. Leak detection equipment shall be set at a percentage of the LFL of the refrigerant and shall be calibrated to the refrigerant employed, and the appropriate percentage of gas (25 % maximum) is confirmed.

- Leak detection fluids are also suitable for use with most refrigerants but the use of detergents containing chlorine shall be avoided as the chlorine may react with the refrigerant and corrode the copper pipe-work.

NOTE:

Examples of leak detection fluids are

- bubble method,
- fluorescent method agents.

- If a leak is suspected, all naked flames shall be removed/extinguished.
- If a leakage of refrigerant is found which requires brazing, all of the refrigerant shall be recovered from the system, or isolated (by means of shut off valves) in a part of the system remote from the leak.

Removal and Evacuation

1. When breaking into the refrigerant circuit to make repairs – or for any other purpose – conventional procedures shall be used. However, for flammable refrigerants it is important that best practice be followed, since flammability is a consideration. The following procedure shall be adhered to:

- safely remove refrigerant following local and national regulations;
 - evacuate;
 - purge the circuit with inert gas (optional for A2L);
 - evacuate (optional for A2L);
 - purge with inert gas (optional for A2L);
 - continuously flush or purge with inert gas when using flame to open circuit, and open the circuit.
2. The refrigerant charge shall be recovered into the correct recovery cylinders if venting is not allowed by local and national codes. For appliances containing flammable refrigerants, the system shall be purged with oxygen-free nitrogen to render the appliance safe for flammable refrigerants. This process might need to be repeated several times. Compressed air or oxygen shall not be used for purging refrigerant systems.
3. For appliances containing flammable refrigerants, refrigerants purging shall be achieved by breaking the vacuum in the system with oxygen-free nitrogen and continuing to fill until the working pressure is achieved, then venting to atmosphere, and finally pulling down to a vacuum (optional for A2L). This process shall be repeated until no refrigerant is within the system (optional for A2L). When the final oxygen-free nitrogen charge is used, the system shall be vented down to atmospheric pressure to enable work to take place.
4. The outlet for the vacuum pump shall not be close to any potential ignition sources, and ventilation shall be available.

Charging Procedures

1. In addition to conventional charging procedures, the following requirements shall be followed.
- Ensure that contamination of different refrigerants does not occur when using charging equipment.
- Hoses or lines shall be as short as possible to minimise the amount of refrigerant contained in them.
- Cylinders shall be kept in an appropriate position according to the instructions.
 - Ensure that the REFRIGERATING SYSTEM is earthed prior to charging the system with refrigerant.
 - Label the system when charging is complete (if not already).
 - Extreme care shall be taken not to overfill the REFRIGERATING SYSTEM.
2. Prior to recharging the system, it shall be pressure-tested with the appropriate purging gas. The system shall be leak-tested on completion of charging but prior to commissioning. A follow up leak test shall be carried out prior to leaving the site.

Decommissioning

Before carrying out this procedure, it is essential that the technician is completely familiar with the equipment and all its detail. It is recommended good practice that all refrigerants are recovered safely. Prior to the task being carried out, an oil and refrigerant sample shall be taken in case analysis is required prior to re-use of recovered refrigerant. It is essential that electrical power is available before the task is commenced.

- a) Become familiar with the equipment and its operation.
- b) Isolate system electrically.

Maintenance Notice

Decommissioning

- c) Before attempting the procedure, ensure that:
- mechanical handling equipment is available, if required, for handling refrigerant cylinders;
 - all personal protective equipment is available and being used correctly;
 - the recovery process is supervised at all times by a competent person;
 - recovery equipment and cylinders conform to the appropriate standards.
- d) Pump down refrigerant system, if possible.
- e) If a vacuum is not possible, make a manifold so that refrigerant can be removed from various parts of the system.
- f) Make sure that cylinder is situated on the scales before recovery takes place.
- g) Start the recovery machine and operate in accordance with instructions.
- h) Do not overfill cylinders (no more than 80 % volume liquid charge).
- i) Do not exceed the maximum working pressure of the cylinder, even temporarily.
- j) When the cylinders have been filled correctly and the process completed, make sure that the cylinders and the equipment are removed from site promptly and all isolation valves on the equipment are closed off.
- k) Recovered refrigerant shall not be charged into another REFRIGERATING SYSTEM unless it has been cleaned and checked.

Labelling

Equipment shall be labelled stating that it has been de-commissioned and emptied of refrigerant. The label shall be dated and signed. For appliances containing FLAMMABLE REFRIGERANTS, ensure that there are labels on the equipment stating the equipment contains FLAMMABLE REFRIGERANT.

Recovery

1. When removing refrigerant from a system, either for servicing or decommissioning, it is recommended good practice that all refrigerants are removed safely.
2. When transferring refrigerant into cylinders, ensure that only appropriate refrigerant recovery cylinders are employed. Ensure that the correct number of cylinders for holding the total system charge is available. All cylinders to be used are designated for the recovered refrigerant and labelled for that refrigerant (i.e. special cylinders for the recovery of refrigerant). Cylinders shall be complete with pressure-relief valve and associated shut-off valves in good working order. Empty recovery cylinders are evacuated and, if possible, cooled before recovery occurs.
3. The recovery equipment shall be in good working order with a set of instructions concerning the equipment that is at hand and shall be suitable for the recovery of the flammable refrigerant. If in doubt, the manufacturer should be consulted. In addition, a set of calibrated weighing scales shall be available and in good working order. Hoses shall be complete with leak-free disconnect couplings and in good condition.
4. The recovered refrigerant shall be processed according to local legislation in the correct recovery cylinder, and the relevant waste transfer note arranged. Do not mix refrigerants in recovery units and especially not in cylinders.
5. If compressors or compressor oils are to be removed, ensure that they have been evacuated to an acceptable level to make certain that flammable refrigerant does not remain within the lubricant. The compressor body shall not be heated by an open flame or other ignition sources to accelerate this process. When oil is drained from a system, it shall be carried out safely.

AACIQ

The design and specifications are subject to change without prior notice for product improvement. Consult with the sales agency or manufacturer for details. Any updates to the manual will be uploaded to the service website, please check for the latest version.

DE-COMMISSIONING, DISMANTLING & DISPOSAL

This product contains refrigerant under pressure, rotating parts, and electrical connections which may be a danger & cause injury. All work must only be carried out by competent persons using suitable protective clothing and safety precautions.



Read the Manual



Risk of Electric Shock

RoHS



Unit is Remotely controlled
& may start without warning



1. Isolate all sources of electrical supply to the unit including any control system supplies switched by the unit. Ensure that all points of electrical and gas isolation are secured in the OFF position. The supply cables and gas pipe work may then be disconnected and removed. For points of connection refer to unit installation instructions.
2. Remove all refrigerant from each system of the unit into a suitable container using a refrigerant reclaim or recovery unit. This refrigerant may then be reused, if appropriate, or returned to the manufacturer for disposal. Under no circumstances should refrigerant be vented to atmosphere. Where appropriate, drain the refrigerant oil from each system into a suitable container and dispose of according to local laws and regulations governing disposal of oily wastes.
3. Packaged units can generally be removed in one piece after disconnection as above. Any fixing down bolts should be removed and then unit lifted from position using the points provided and equipment of adequate lifting capacity. Reference **MUST** be made to the unit installation instructions for unit weight and correct methods of lifting. Note that any residual or spilt refrigerant oil should be mopped up and disposed of as described above.
4. After removal from position the unit parts may be disposed of according to local laws and regulations.
5. Meaning of crossed Out wheeled dustbin: Do not dispose of electrical appliances as unsorted municipal waste, use separate collection facilities. Contact your local government for information regarding the collection systems available. If electrical appliances are disposed of in landfills or dumps, hazardous substances can leak into the groundwater and get into the food chain, damaging your health and well being. When replacing old appliances with new ones, the retailer is legally obligated to take back your old appliance for disposals at least free of charge.