

GENESIS

15kW-17kW Package Units

Installation and Commissioning Guide



Model Numbers

PRV15BT-TFFT-EV*

PRV17BT-TFFT-EV*

PRV15BT-TVFT-EV

PRV17BT-TVFT-EV

Under/Over Unit

* Front discharge Air Handling Option shown for illustration purposes only.

R32 LOW GWP
REFRIGERANT



A2L

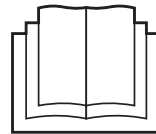

The system is charged with flammable refrigerant, safety checks are necessary to ensure that the risk of ignition is minimised.

IMPORTANT NOTE:

This unit is designed for use with R-32 refrigerant only. Please read the R-32 Safety Manual and this manual carefully before installing or operating your air conditioning unit. Information in this manual is to be used in conjunction with the R-32 Safety Manual. Make sure to save this manual for future reference.

ActronAir

Table of Contents

| | |
|---|-----------|
| Introduction | 4 |
| General Information | 5 |
| Safety Instructions | 7 |
| Installation Information | 8 |
| Operation Manual Access | 9 |
| Wall Controller Options | 10 |
| Wall Controller Options | 10 |
| Wiring Configuration : Recommended | 11 |
| Wiring Configuration : Alternate | 12 |
| Components Overview | 13 |
| Control Panel | 14 |
| Electrical Control Panel | 15 |
| Compressor Variable Speed Drive (VSD) Assembly - Front | 16 |
| Compressor Variable Speed Drive (VSD) Assembly - Back | 16 |
| Unit Dimensions, Clearances and Weights | 17 |
| PRV15BT-TFFT-EV / PRV17BT-TFFT-EV | 17 |
| Service Clearances, Airflow Allowances and Weights | 18 |
| Unit Lifting Procedure | 19 |
| Outdoor Unit Preparation | 21 |
| Condensate Drainage Instructions | 22 |
| Suggested Minimum Slope To Ensure Correct Drainage | 22 |
| Suggested Drain Trap Details | 22 |
| Electrical Installation | 23 |
| Wiring Diagram | 24 |
| Electrical Connection | 26 |
| Package Unit | 26 |
| Circuit Breaker Size Recommendation | 27 |
| Wiring Connections | 28 |
| LC7-2 Wall Control Wiring Connections | 28 |
| NEO Wall Control Wiring Connections | 28 |
| LM-RS-2 Optional Sensor Wiring Connections | 29 |
| AERSS Optional Duct Sensor Wiring Connections | 29 |
| Configuring and Commissioning Setup | 30 |
| Menu and Navigation | 30 |
| Configuring Compressor and Capacity(cnFg) | 31 |
| Configuring Control Source (CtrS) | 31 |
| Demand Response Management | 32 |
| Third Party Control Input (Indoor and/or Outdoor Board) | 33 |
| 0-10V Analogue Input for Compressor and Indoor Fan | 33 |
| 0-10V Analogue Input for Compressor with Fixed Indoor Fan Speed | 34 |
| Input for Fixed Compressor with Fixed Indoor Fan Speed | 35 |
| 0-10V Analogue Input for Indoor Fan with Fixed Speed Compressor | 35 |
| Run and Fault Indication Output (Outdoor Board) | 36 |
| Remote On/Off | 37 |

Table of Contents

| | |
|--|-----------|
| Indoor Fan Commissioning | 38 |
| PRV15BT | 38 |
| PRV17BT | 40 |
| Refrigerant Charging | 42 |
| Charging Method: Subcooling and Superheat | 43 |
| Maintenance | 46 |
| Maintenance Frequency Checklist | 48 |
| Version History | 50 |

Introduction

CONGRATULATIONS on your purchase of an ActronAir air conditioning system! This unit has been designed and engineered to provide optimum air conditioning and to achieve maximum energy efficiency.

Your air conditioning system has been manufactured from the highest quality materials. Numerous “in house” and “external” inspection and test procedures were conducted to your air conditioner to ensure satisfactory operation.

Information About This Guide

This guide provides installation instructions, specific to your ducted unit. Read this manual thoroughly and take into consideration all specifications and instructions to ensure correct installation and safe operation of your air conditioning system.

NOTE

Print a copy of this document and keep it for future reference. Ensure all technicians that work on the unit can refer to this manual at any time.

Product Inspections

Check your air conditioning unit and all items against the invoice upon receiving your shipment. Inspect the unit, components and accessories for any sign of damage. If there is any damage to the unit, contact ActronAir Customer Care Department immediately on: **1300 522 722** to obtain a Goods Return Number.

Check the unit nameplate to verify the model, serial number, electrical rated specifications are correct.

Codes, Regulations And Standards

The installer and/or contractor assumes responsibility to ensure that unit installation complies with the relevant council, state / federal codes, regulations and building code standards. All electrical wiring must be in accordance with current electrical authority regulations and all wiring connections to be as per electrical diagram provided with the unit in accordance with the latest edition of the AS/NZS 3000 (also known as Australian Wiring Rules) or AS/NZS 3008.

Important Safety Symbols And Labels

Safety Symbols and labels appear at appropriate sections throughout this manual to indicate immediate or potential hazards. Pay full attention and comply to the safety information and instructions. Failure to follow safety instructions increases the risks of personal injury, death and/or property damage. Damages to the product as a result of such failure may void warranty.

ActronAir has endeavoured to provide sufficient safety warnings and recommendations, however current and prevailing WH&S regulations must be observed and will take precedent whenever performing the installation instructions discussed in this manual.

General Information

ActronAir air conditioning units are designed for applications where superior performance, high efficiency, reliability, supply air quality and quiet operation are the prime priorities. The units are built with the latest technologies advanced variable speed driven inverter compressor, EC outdoor/indoor fans, low-noise outdoor fans, electronic expansion valve and an intelligent electronic control.

For optimum efficiency, your air conditioning unit will deliver just the right amount of cooling or heating capacity.

Energy Efficient Refrigeration Circuits

The ActronAir system is designed with a highly efficient refrigeration circuit that delivers only the amount of cooling or heating actually required to maintain your desired comfort at the most optimum efficiency.

Each refrigeration circuit consists of:

- High efficiency variable capacity scroll compressor with individual compressor drive
- Hydrophilic coated condenser coil designed for optimum performance and efficiency with corrugated fins and ruffled tubing
- Hydrophilic coated evaporator coil designed for optimum performance and efficiency with lanced fins and ruffled tubing
- Electronic expansion valve (EEV), to maintain efficiency at across a wide range of operating conditions

Evaporator Section

The evaporator section has EC fans which deliver just the right amount of airflow, depending on requirements. The fans provide superior performance for your comfort at optimum efficiency:

- Highly efficient variable speed EC motor that uses less energy than the traditional fixed speed induction motor
- Easy indoor fan commissioning via intelligent controllers
- Low noise operation
- Adjustable Indoor Airflow

Condenser Section

Uses two (2) EC axial fans and state of the art Inverter Compressor, with the following features:

- Efficient Tru-Inverter Compressor and Inverter Drive combination
- Efficient axial fans with direct drive EC motor
- Low noise operation
- Variable compressor capacity
- Variable speed outdoor fan

Electrical Section

The electrical section is composed of a panel for controls, protecting the components from the elements and a separate panel enclosure for the variable speed drive.

Durable Design and Construction

ActronAir is an Australian manufacturer with proven high quality air conditioning products. Known for their durability and reliable performance, these products are designed and built to withstand the extreme Australian weather conditions.

The galvanized steel cabinet, with powder coated epoxy enamel finish, resists the toughest conditions. The louvered outdoor coil guard protects the condenser coil from any potential damage brought by hail, stones and other solid objects that may be projected to the unit.

Blue Hydrophilic coil fins provide protection to your heat exchangers and enhanced heat transfer with increased performance efficiency.

External fasteners in all Outdoor and Package unit are stainless steel screws Gem-Cote coating.

System Flexibility

The ActronAir Variable Capacity range air conditioning units are the first choice for residential and commercial applications, both for new construction or retrofitting projects.

Refrigerant Handling and Accountability

ActronAir strongly urges that all service technicians make every effort possible to eliminate and/or vigorously reduce the emission of refrigerants to the atmosphere. Everyone must act in a responsible manner to conserve refrigerants in accordance to the industry code of practice.

Sustainability and Environmentally Friendly

The air conditioning system is supplied with zero ozone depleting refrigerant.

With cooling and heating performance capacity that are among the best in the market, the ActronAir air conditioning units provide the solution for the reduction of energy consumption, CO₂ emission, high fuel dependency and high network grid demand.

Safety Instructions

- Only licensed HVAC technicians* should install and service air conditioning equipment. Improper service or alteration by an unqualified technician could result in significant and major damage to the product or property which may render your warranty null and void. Such unqualified service could also lead to severe physical injury or death. Follow all safety instructions in this literature and all warning labels that are attached to the equipment.
- Prevailing WH&S regulations must be observed and will take precedence to the safety instructions contained on this manual. Safe work practices and environment must be the paramount importance in the performance of all the service procedures.
- Ensure that unit installation complies with relevant council regulations and building code standards.
- All electrical wiring must be in accordance with current electrical authority regulations and all wiring connections to be as per electrical diagram provided in accordance with the latest edition of the AS/NZS 3000 (also known as Australian Wiring Rules).
- Secure the fans against accidental contact. Beware of pinch point and sharp edges which can cause cutting injury.
- Always wear appropriate PPE, remove any dangling jewelery and protect long hair by wearing a cap.
- Make sure that safety guards and panel covers are always firmly secured and not damaged before and during operation of unit.
- This appliance is not intended for use by young children or infirm persons unless they have been adequately supervised by a responsible person to ensure that they can use the appliance safely. Young children should be supervised to ensure that they do not play with the appliance.
- Installer must incorporate a means of electrical disconnection (isolator) in the sub mains fixed wiring in accordance with the latest edition of the AS/NZS 3000 (also known as Australian Wiring Rules).
- Secure the power cords and control cables that goes in/out the unit. Use the cable ties provided in the control box.
- This unit is designed for use with R-32 refrigerant only.

*Qualifications required will be appropriate Electrical, Refrigeration and Refrigerant Handling License and Training dependent on local State/Territory regulations.

DANGER

Hazardous Voltage - Risk of Electrocutation.

TURN-OFF the power from main isolator before proceeding with any service work of the unit. Observe proper LOCK-OUT/TAG-OUT (LOTO) procedures for electrical appliances in order to prevent accidental switching-on of the power supply.

WARNING

EC Motors and Compressor Drives are fitted with high power capacitors and can have dangerous residual voltages at motor/drive terminals after power has been isolated. Wait at least 5 minutes after power isolation and test for any residual voltage before beginning service work.

CAUTION

Beware of Rotating Fans !

Ensure that indoor and outdoor fans are isolated and have come to a complete stand still before servicing the equipment. Beware of pinch point and sharp edges which can cause cutting injury. Secure the fans against accidental contact. Always wear appropriate PPE and remove any dangling jewellery and protect long hair by wearing a cap. Ensure that no loose clothing can be caught / entangled in moving parts.

VISUAL INSPECTION AND WORK ASSESSMENT

Work areas and conditions must first be assessed and evaluated for any potential hazardous conditions. It is also important to be familiar with the unit parts and components before proceeding with any service task.

Installation Information

All service technicians handling refrigerant must be licensed to handle refrigerant gases.

Recover and Recycle Refrigerants

Never release refrigerant to the atmosphere! It is an offence in Australia to do so. Always recover, recycle and reuse refrigerants. When removing from the system, properly contain and identify refrigerants in its dedicated container for proper disposal and/or storage. Always consider the recycle or reclaim requirements of the refrigerant before beginning the recovery procedures. Obtain a chemical analysis of the refrigerant if necessary. For the recovered refrigerant and acceptable refrigerant quality, refer to the existing standards and regulations.

Refrigerant Handling and Safety

Consult the refrigerant manufacturer's Material Safety Data Sheet (MSDS) for information on proper handling and to fully understand health, safety, storage and disposal requirements. Use the approved containment vessels and refer to appropriate safety standards. Comply with all applicable transportation standards when shipping refrigerant containers.

Service Equipment and Recovery Procedures

Always use refrigerant reclaiming equipment in order to minimise refrigerant emissions. Use equipment and methods which will pull the lowest possible system vacuum while recovering and condensing refrigerant. Equipment capable of pulling a vacuum of less than 500 microns is required.

Do not open the system to the atmosphere for service work until refrigerant is fully removed and/or recovered. Perform refrigeration system evacuation, prior to charging, in accordance with AIRAH / IRHACE Refrigerant handling code of practice.

Let the unit stand for 1 hour and with the vacuum not rising above 500 microns. A rise above 500 microns indicates a leak from the system and a leak test is required to locate and repair any leak.

CAUTION

A leak test is always required on any repaired section of the refrigeration system.

Charge refrigerant into the system only after the equipment does not leak or contain moisture. Take into consideration the correct amount of refrigerant charge specified for the system to ensure efficient unit operations. When charging is complete, reclaim refrigerant from charging lines into an approved refrigerant container. Seal all used refrigerant containers with approved closure devices to prevent unused refrigerant from escaping to the atmosphere. Take extra care to maintain all service equipment directly supporting refrigerant service work such as gauges, hoses, vacuum pumps and recycling equipment.

INSTALLATION PREPARATION (Pre-Installation considerations)

The following items must be considered before beginning the unit installation:

- Verify the unit capacities and ratings with the unit nameplate.
- Make certain the floor or foundation is level, solid and has sufficient structural strength to support the unit and accessories weight.
- Allow minimum recommended clearances for periodic maintenance and service access.
- Allow sufficient space above the unit for the outdoor air discharge. Condenser air inlet, located on the coil side of the unit, requires sufficient airflow clearance for the optimum unit performance.
- Note the conditioned supply air and return air location. Ensure sufficient spaces are allocated for these purposes.
- For the connection and location of condensate drain in the unit, refer to the drawings and dimensions section of this manual.

- Wiring connections must be in accordance with the wiring diagram provided with the unit.
- Make sure all wirings are in accordance with local electricity authority regulations and standards.
- Do not install the unit close to an area where there is a danger of fire due to volatile, explosive, flammable and/or hazardous materials.
- Ensure that spaces around the unit are free from any obstructions for optimum unit performance.
- Installer to ensure correct size/type that main circuit breaker and cable is installed in unit sub-mains to protect the sub-mains and unit wiring.
- Installer to ensure correctly rated residual current device (RCD) is installed as per the latest edition of the AS/NZS 3000 (also known as Australian Wiring Rules).
- Secure the power cords and control cables that goes in/out the unit. Use the cable ties provided in the control box.

 **CAUTION**

This outdoor unit is designed to match only with an ActronAir indoor unit as specified in the Technical Selection Catalogue. The unit is supplied with factory charged refrigerant as stated in the Rating Label. The use other material as a refrigerant may cause explosion and/or personal injury. Be aware of all the relevant regulations concerning the handling of refrigerant.

For units charged with R-32

R-32 refrigerant (CLASS A2L) is mildly flammable.

Thoroughly read and understand the accompanying R-32 Safety Guide for installation and maintenance instructions. Installation, service, maintenance, repairs and decommissioning of this unit must be performed by a licensed HVAC technician; qualified to handle R-32 refrigerant.

Appliance shall be installed, operated and stored in a well ventilated area:

- where the room size corresponds to the room area as specific for operation.
- without continuously operating open flames (for example an operating gas appliance) and ignition sources (for example an operating electric heater).
- away from other potential continuously operating sources that known to cause ignition of R-32 refrigerant.

R-32 refrigerant is odorless if the refrigerant gas comes into contact with fire, it may emit a poisonous gas.

 **WARNING**

- Do not use means to accelerate the defrosting process or to clean a unit, other than those recommended by manufacturer.
- The appliance shall be stored in a room without continuously operating ignition sources (for example: open flames, an operating gas appliance or an operating electric heater).
- Do not pierce or burn any component of the pipework or system.
- Be aware that the R-32 refrigerant may not contain an odour.
- The appliance shall be stored so as to prevent mechanical damage from occurring.

Operation Manual Access

Download from website

Operation manuals can be downloaded through our website shown below.

<https://actronair.com.au/manuals/>

Wall Controller Options

Wall Controller Options

A maximum of three (3) wall controllers in the below combinations is allowed per unit. See below table.

| Options | Wall Controllers | | |
|------------|------------------|-------|-------|
| | C1 | C2 | C3 |
| 1st Option | NEO | | |
| 2nd Option | NEO | NEO | |
| 3rd Option | NEO | NEO | LC7-2 |
| 4th Option | NEO | LC7-2 | |
| 5th Option | NEO | LC7-2 | LC7-2 |
| 6th Option | LC7-2 | | |
| 7th Option | LC7-2 | LC7-2 | |
| 8th Option | LC7-2 | LC7-2 | LC7-2 |

NOTES

- NEO - Available in White (NTW-1000) and Black (NTB-1000).
- LC7-2 and LM-RS-2 - Available in White and Grey.
- In the instance of a combination of NEO and LC7-2 being connected together, the NEO will always need to be addressed as C1.
- Refer to catalogue for available controller for this product.

Wiring Configuration : Recommended

NOTES

- Diagram shown below is a general representation only. Refer to individual unit wiring diagram for complete wiring connection details.
- Long runs beside Mains cables or TV antenna cables should be avoided.
- Daisy connection is not allowed for the NEO wall controller.
- Two Ferrite Clips*, if supplied, are to be placed 200mm and 400mm from the NEO controller respectively.

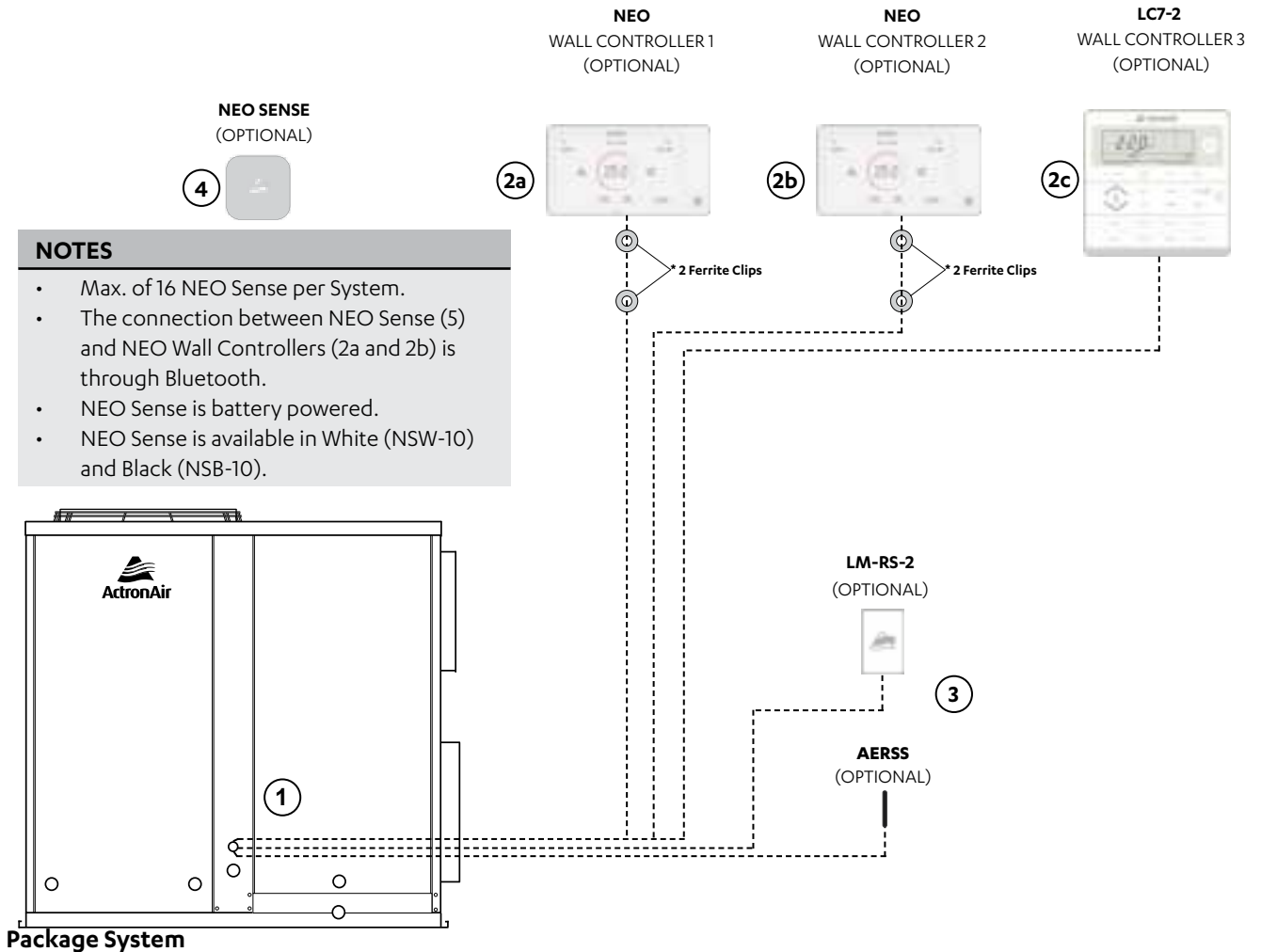

NOTES

- Max. of 16 NEO Sense per System.
- The connection between NEO Sense (5) and NEO Wall Controllers (2a and 2b) is through Bluetooth.
- NEO Sense is battery powered.
- NEO Sense is available in White (NSW-10) and Black (NSB-10).

| Item | Description | Maximum Cable Length |
|------------------|------------------------------------|----------------------|
| 1 to 2a, 1 to 2b | Indoor PCB to Wall Control 1 and 2 | 90 m |
| 1 to 2c | Indoor PCB to Wall Control 3 | 100 m |
| 1 to 3 | Indoor PCB to Remote Sensor | 100 m |

| Description | Cable Type |
|------------------------------------|-------------------------------|
| LC7-2 and NEO Field Control Wiring | Cat5E UTP (AWG 24) Data Cable |
| Indoor to Remote Sensor | Cat5E UTP (AWG24) Data Cable |

Wiring Configuration : Alternate

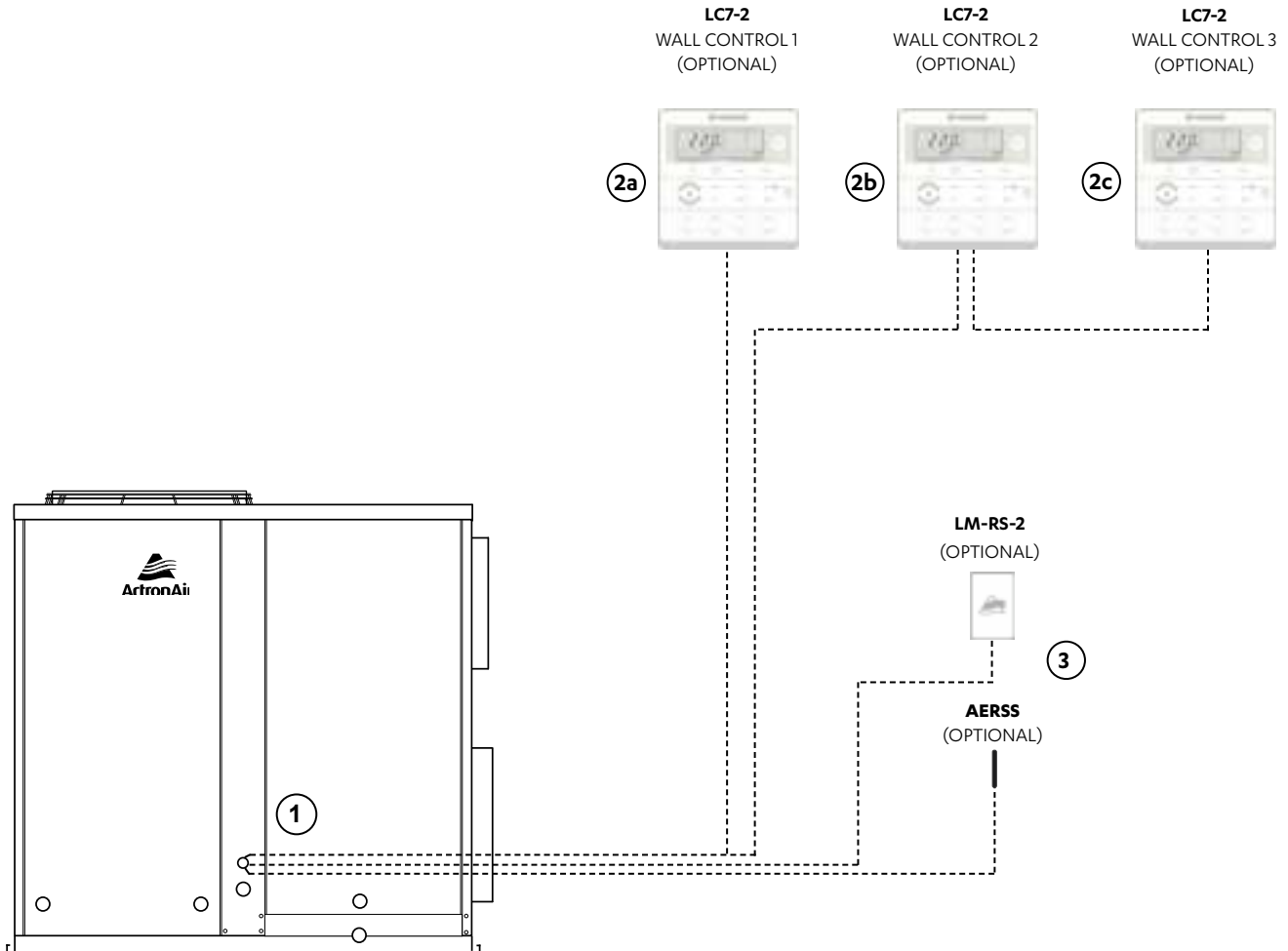

NOTES

- Diagram shown above is a general representation only. Refer to individual unit wiring diagram for complete wiring connection details.
- Long runs beside Mains cables or TV antenna cables should be avoided where possible.

Package System

| ITEM | DESCRIPTION | MAXIMUM CABLE LENGTH |
|---------|---|--------------------------|
| 1 to 2a | Indoor PCB to Wall Control 1 (optional) | 100 m |
| 1 to 2c | Indoor PCB to Wall Control 3 (optional) | 75m total (Daisy Chain)* |
| 1 to 3 | Indoor PCB to Remote Sensor | 100 m |

* Maximum Daisy Chain connection is up to 2 Wall Control.

| DESCRIPTION | CABLE TYPE |
|----------------------------|-------------------------------|
| LC7-2 Field Control Wiring | Cat5E UTP (AWG 24) Data Cable |
| Indoor to Remote Sensor | Cat5E UTP (AWG24) Data Cable |

Components Overview

NOTE

Drawing is for illustration purposes only. Model may vary depending on unit purchased.

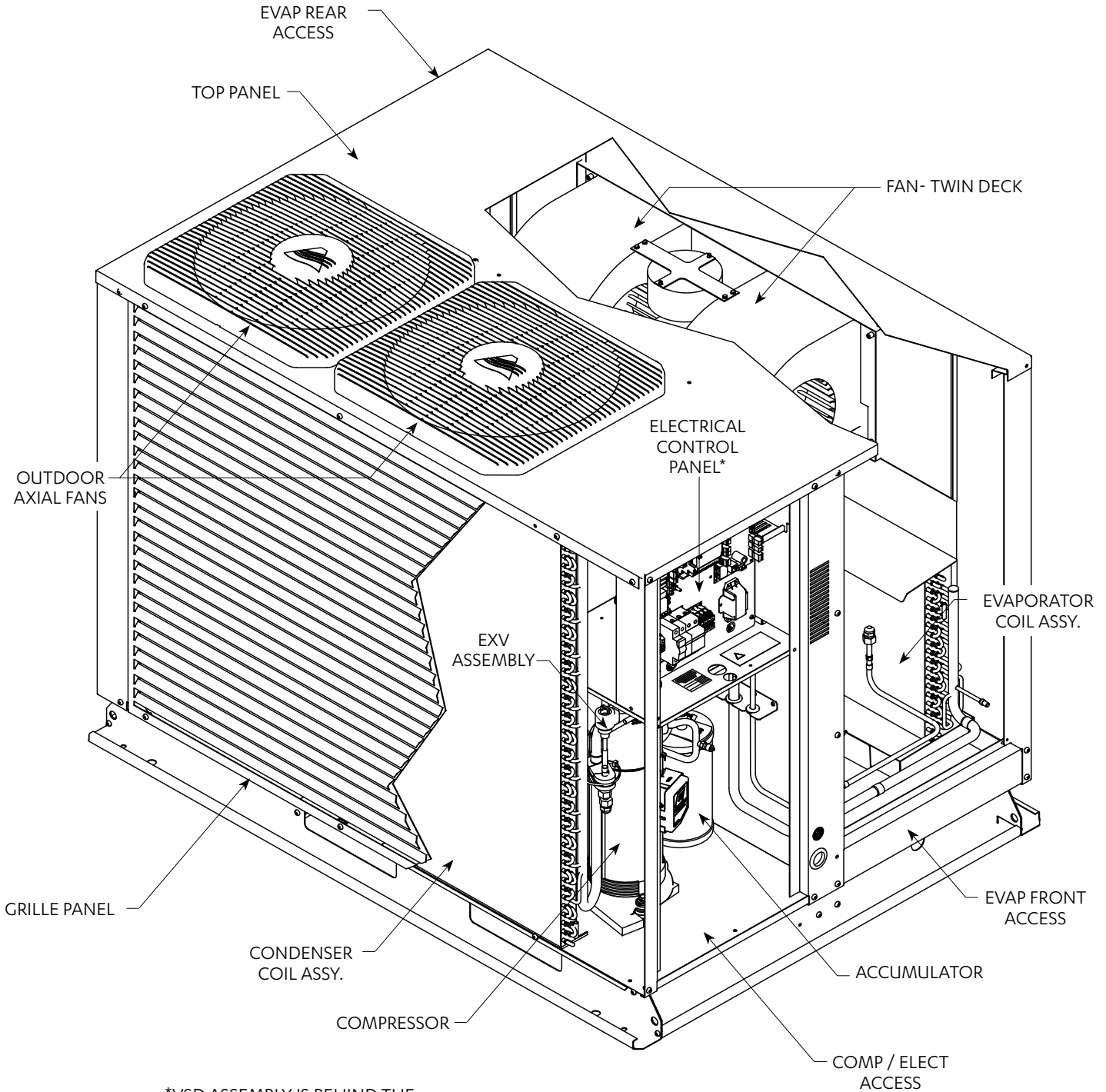

*VSD ASSEMBLY IS BEHIND THE ELECTRICAL CONTRL PANEL

Control Panel

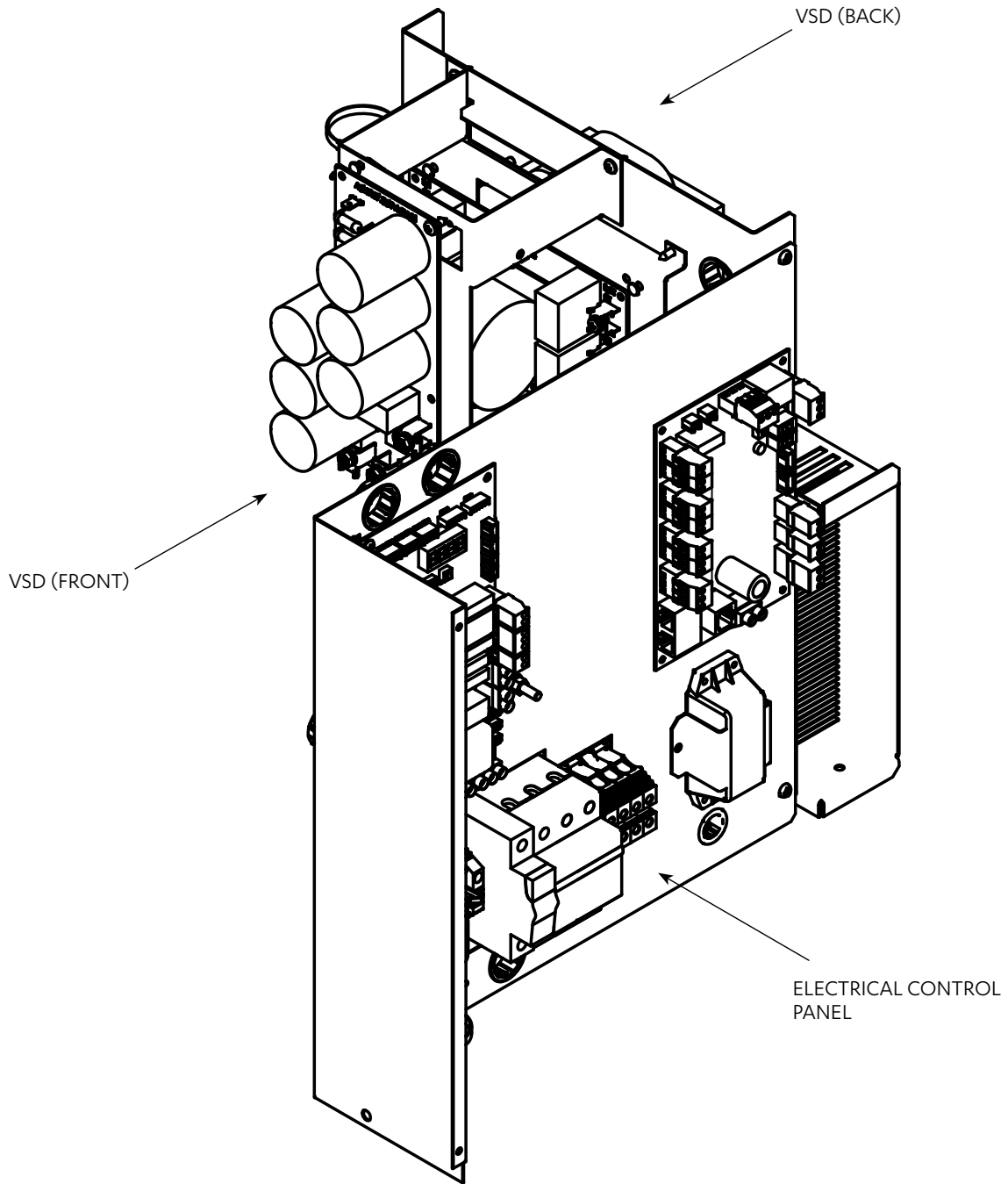

Electrical Control Panel

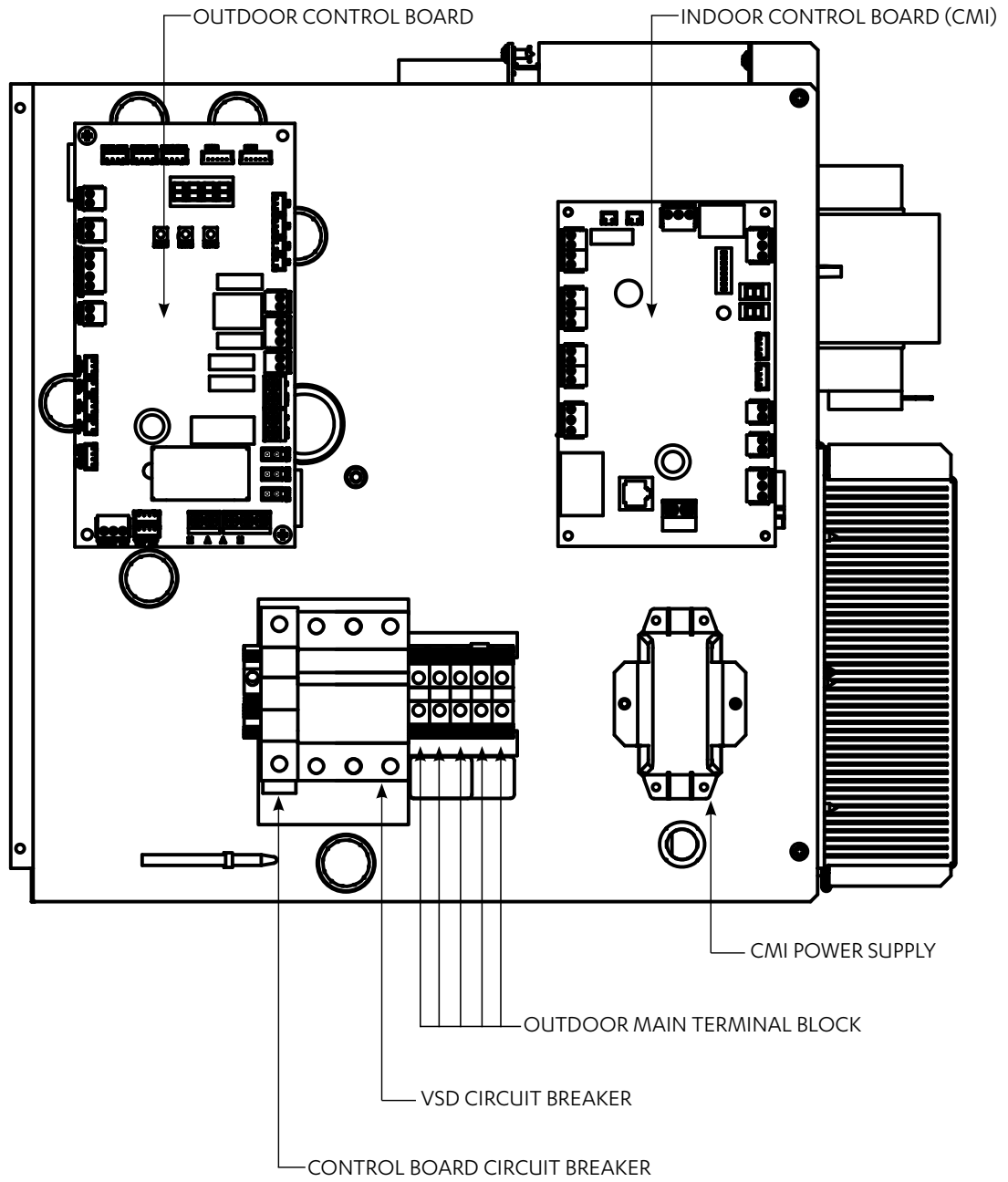

Compressor Variable Speed Drive (VSD) Assembly - Front

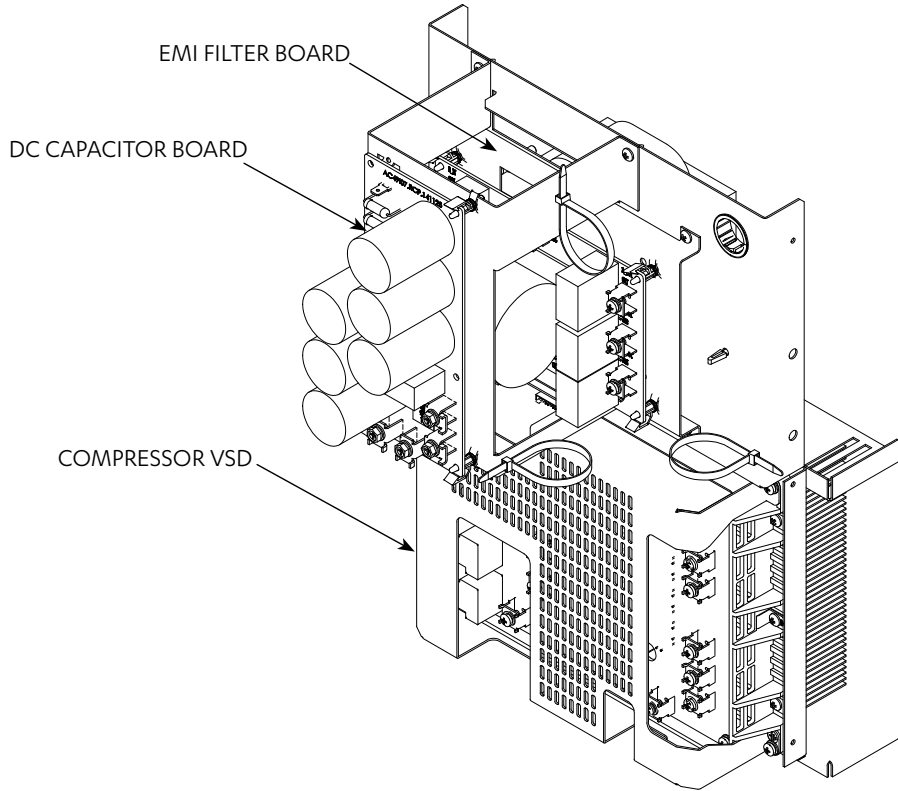

Compressor Variable Speed Drive (VSD) Assembly - Back

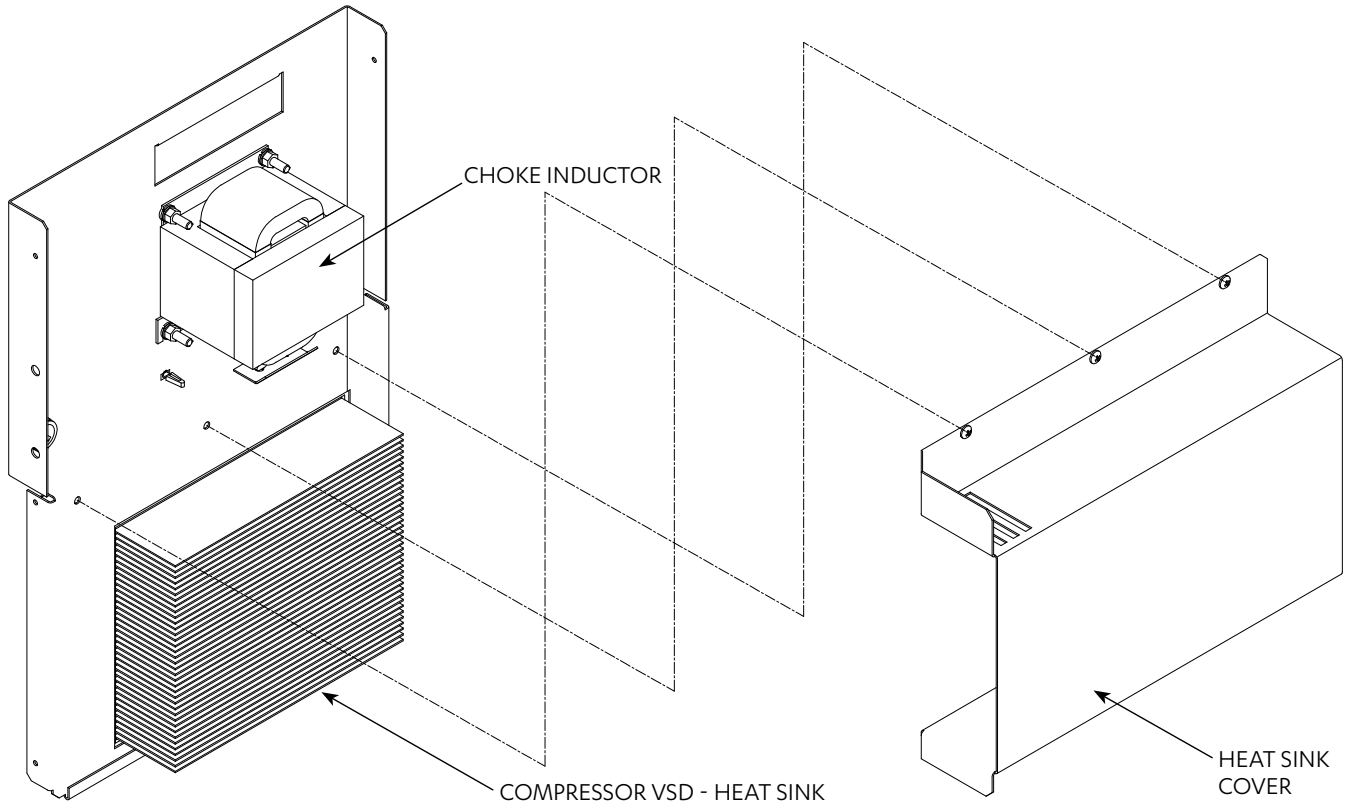

Unit Dimensions, Clearances and Weights

PRV15BT-TFFT-EV / PRV17BT-TFFT-EV

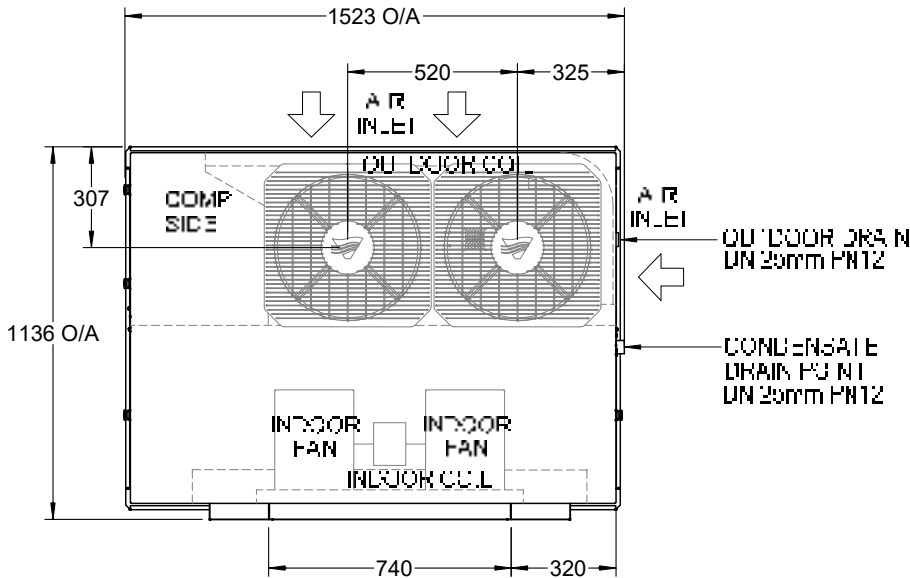

CONDENSATION POINTS ARE DESIGNED TO ENSURE ALL CONDENSATION IS REMOVED EFFICIENTLY TO AVOID WATER POOLING WITHIN THE CONDENSER. IF A SINGLE CONDENSATION DRAIN POINT IS REQUIRED, ACTRONAIR RECOMMENDS THE INSTALLATION OF A CONDENSER TRAY.

DRAWING IS SUBJECT TO CHANGE WITHOUT NOTICE

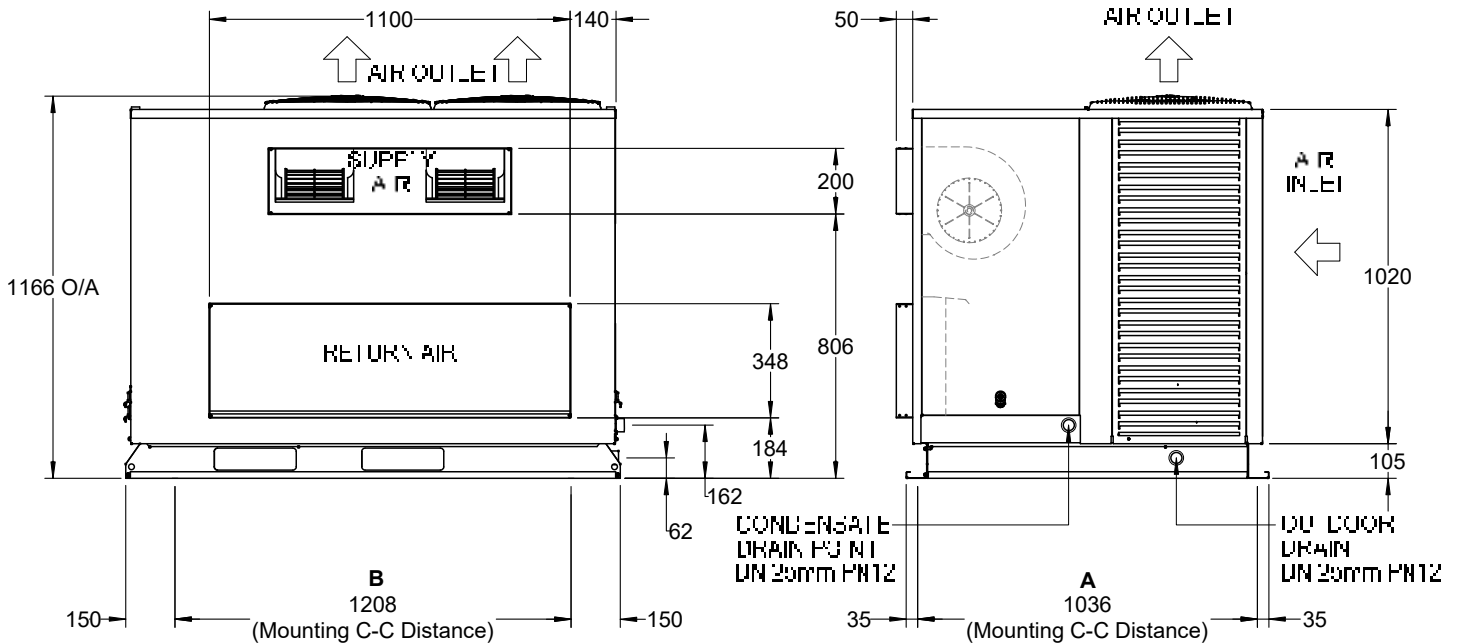

| Unit Model Number | Overall Nominal Dimension (OA) | | | Supply Duct | Return Duct | Mounting Distance Base Foot (Centre to Centre) | |
|-------------------|--------------------------------|------|------|-------------|-------------|--|------|
| | H | W | D | | | A | B |
| PRV15BT-T | 1166 | 1523 | 1136 | 200 x 740 | 348 x 1100 | 1036 | 1208 |
| PRV17BT-T | | | | | | | |

Service Clearances, Airflow Allowances and Weights

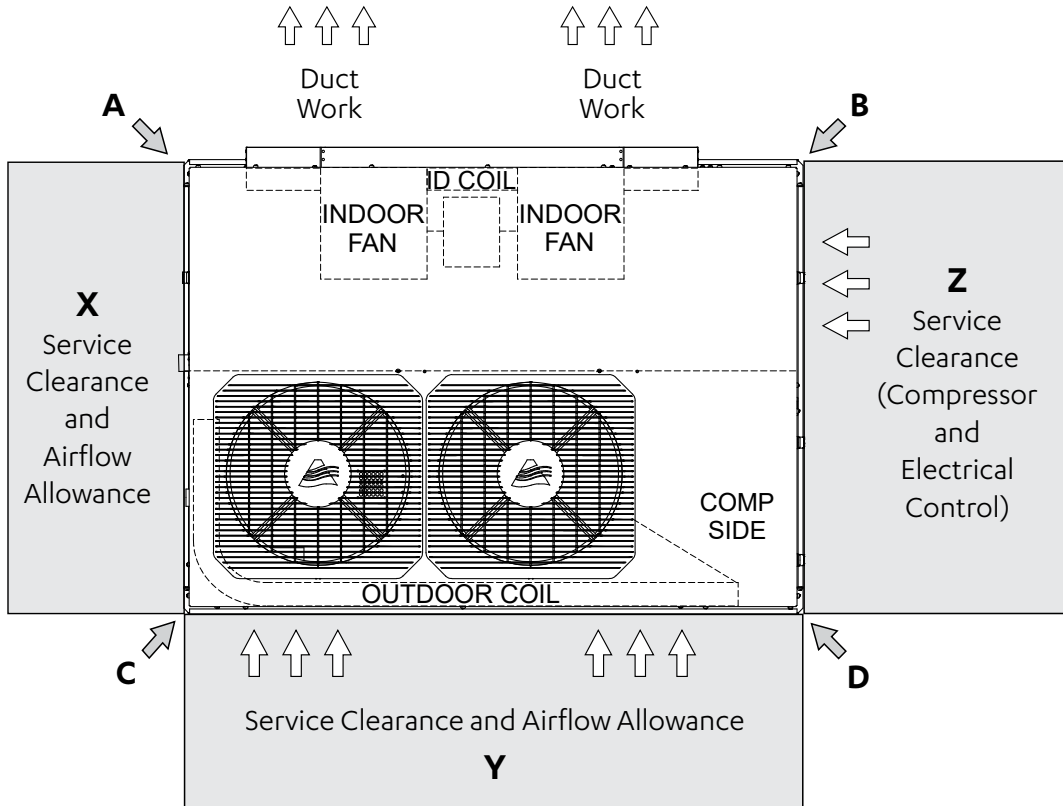

NOTES:

1. Do not scale drawing. All dimensions are in mm unless otherwise specified. Refer to corresponding unit dimensional drawing for mounting hole details.
2. Service Access Areas and Spaces for Airflow Clearances are suggested minimum based on the condition that the spaces around the units are free from any obstructions and a walkaway passage of 1000 mm between the units or between the unit and the outside perimeter is available.
3. Minimum service access areas and spaces for airflow clearances are responsibilities of the installer, ActronAir will not be held liable for any extra charges incurred due to lack of access and space for airflow.
4. Under all circumstances, condenser air must not recirculate back onto condenser coil. Keep all clearance free of any obstruction.
5. Mounting C-C Distance = Mounting Centre to Centre Distance.
6. Use M12 bolt for feet mounting.
7. Installation of this unit should be in accordance with Electrical Safety Standard, AS/NZS 60335.2.40.
8. Additional safety provision maybe needed such as leak detector sensor and/or ventilation to meet the minimum area requirement. For more details refer to Annex GG and Annex HH of the above standard.
9. Refer to R-32 Safety Manual for minimum required area of installation.

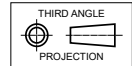

| Unit Model Number | Total Weight (Kg) | Corner Weights (Kg) | | | | Service Clearance and Airflow Allowance | | | Height Clearance |
|-------------------|-------------------|---------------------|----|----|----|---|-----|-----|------------------|
| | | A | B | C | D | X | Y | Z | |
| PRV15BT-T | 233 | 46 | 63 | 57 | 67 | 300 | 400 | 600 | 1500 |
| PRV17BT-T | 242 | 49 | 66 | 59 | 68 | | | | |

Unit Lifting Procedure

WARNING

WH&S regulations must be observed and will take precedence during lifting process.

NOTE

All drawings are for illustration purposes only. Actual unit may vary depending on the model.

Crane Lifting Method

Crane lifting method is recommended for high rise lifting.

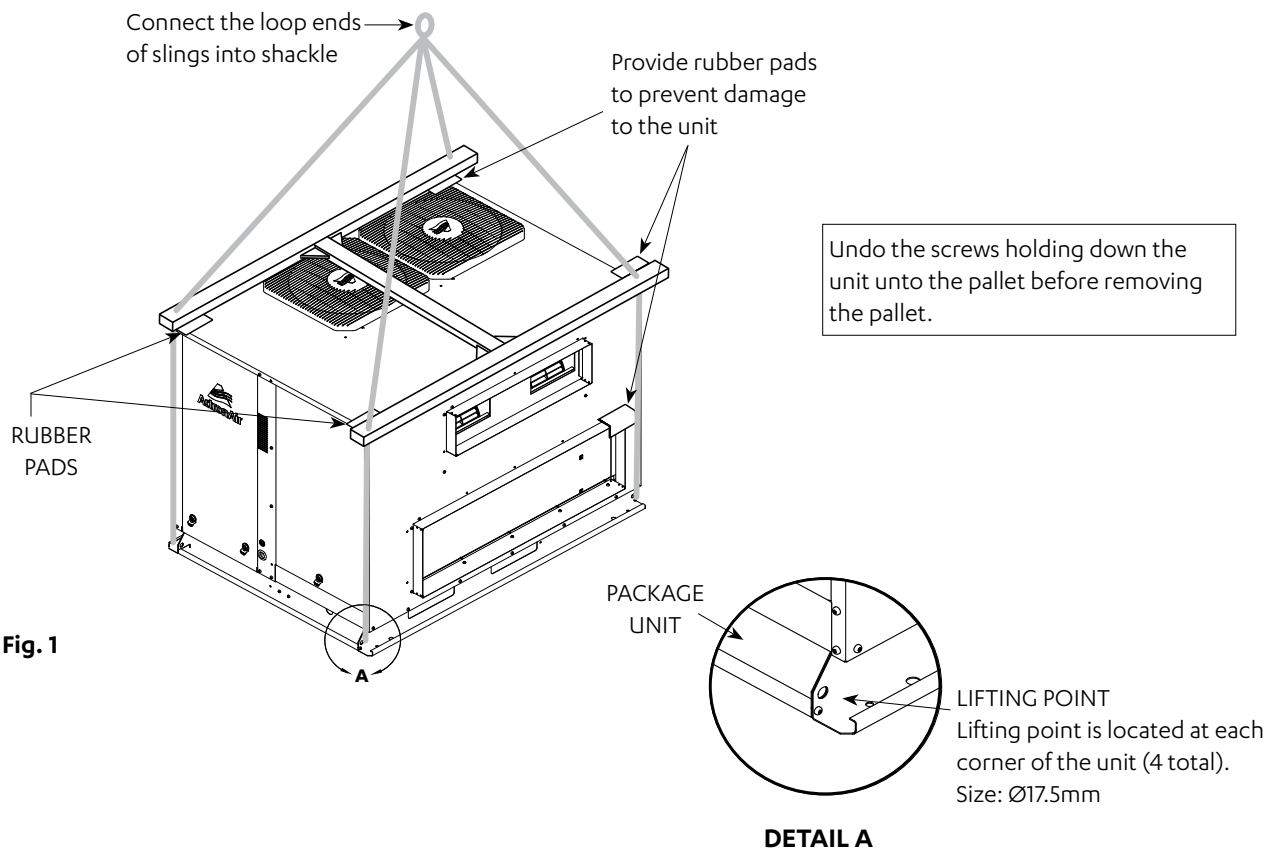

Fig. 1

Equipment Required For Crane Lifting:

- 1 Shackle
- 2 x Nylon Slings
- Spreader bars

NOTE

Refer to Unit Dimensions and Clearances section for unit weight before selecting shackle and slings.

Procedure:

1. Slip nylon slings through the pallet as shown in Fig. 1.
2. Use a Bow or Dee shackle to connect the slings.
3. Ensure slings are protected by rubber pads or similar if slings are draped across unit edges, corners, or air grilles. This will prevent the unit from being damaged during lifting.

4. SPREADER BARS must be used when lifting the unit. Ensure that the spreader bar is slightly larger than the base.
5. Test lift the unit to determine exact unit balance and stability before hoisting it to the installation location.

Fork Lift Method

DANGER

Make sure rigging equipment, accessories and plant are sufficiently and safely capable to lift the unit in order to prevent potential damage to property, severe personal injury or death. Please check unit weight and weight distribution points as shown in the unit drawing dimensions section.

Procedure:

1. To move the unit around with a forklift, insert the fork tines through the pallet, as shown in Fig. 2.
2. Only fork the unit through compressor end or side of the unit. (See illustration for location of compressor end)

Fig. 2

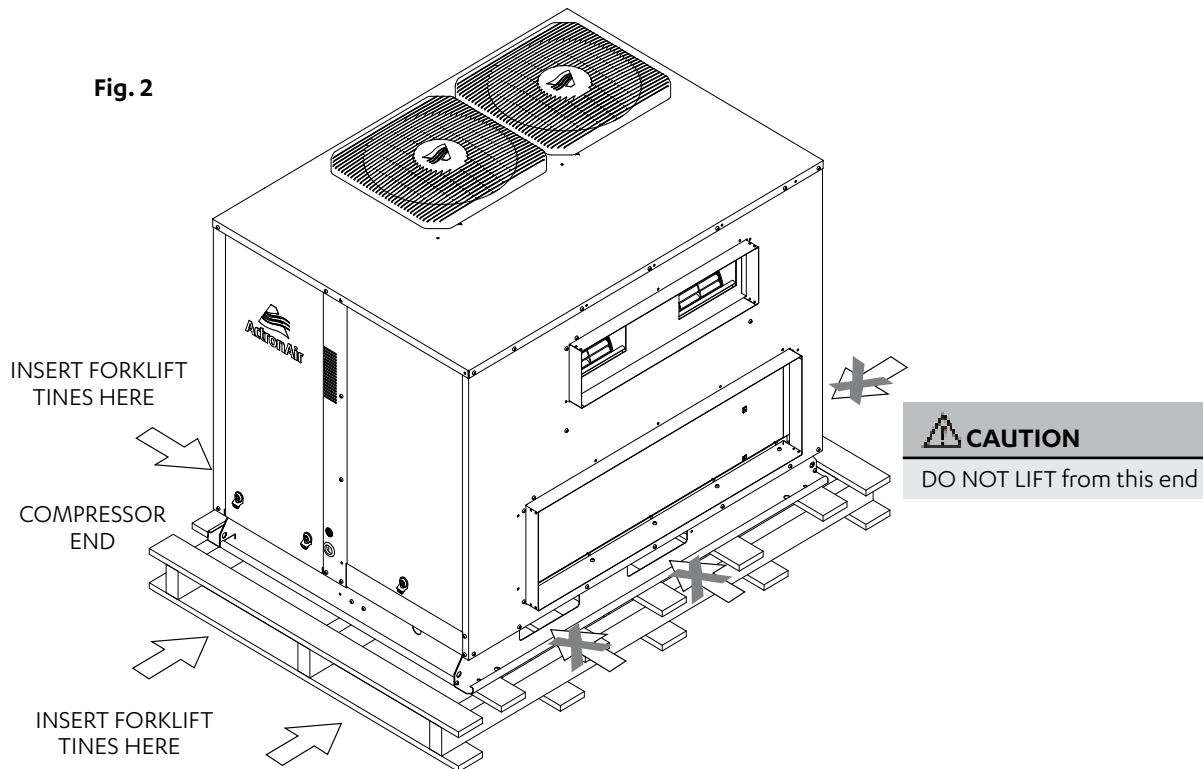

CAUTION

Length of fork lift tines must pass the unit middle section, in order to safely carry the unit.

Outdoor Unit Preparation



WARNING

Live electrical within enclosure. Isolate electrical supply before removing panels.
 Authorised technicians access only.

1. Rotate the Hex Recess 90 degrees using 8mm allen key and remove the Access Panel-Electrical as illustrated below.

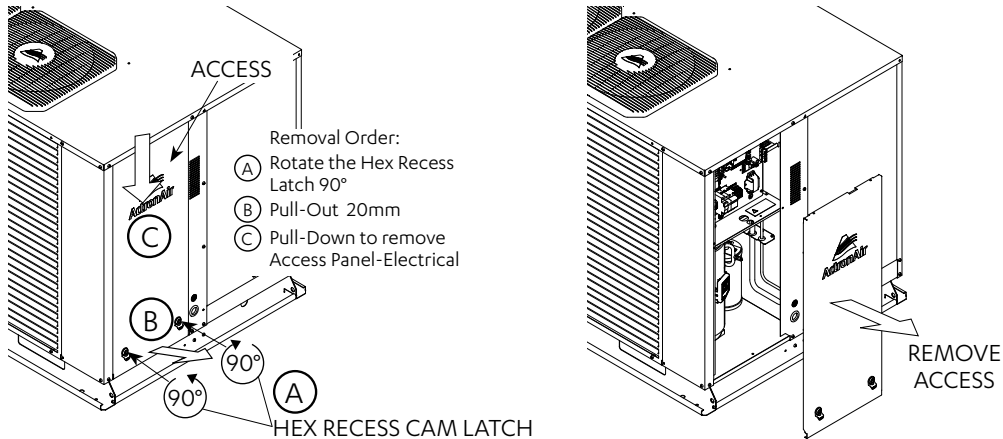

2. Remove the Shipping Blocks before installing.

- a. Loosen the set bolts that hold the compressors down onto the unit (3 pcs).

- b. Remove Shipping blocks as shown below.

- c. Tighten back the set bolts that hold the compressors down onto the unit (12 to 14Nm).

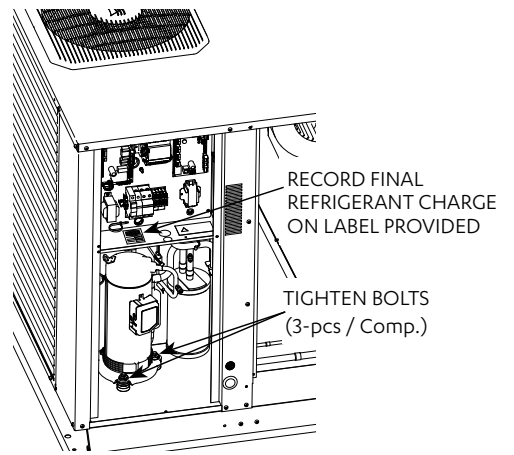
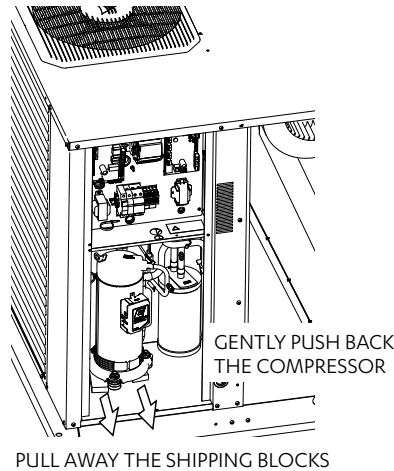
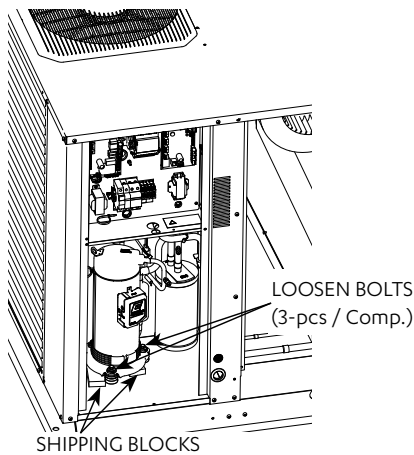

Condensate Drainage Instructions

NOTES

- Do not use pipes or tube coming out from the unit to lift the unit.
- Support drain line for long pipe run.
- Parts for the Condensate Trap are not supplied with the unit.
- Refer to unit dimension page for specification of drain connectors.
- Test condensate drain installation to ensure that water flows freely and does not leak. Also check that the drain tray does not overflow.
- To reduce the risk of condensation forming on the drain line, the drain line should be covered with appropriate thermal insulation.
- All drawings are for illustration purposes only. Actual unit may vary depending on the model.

Suggested Minimum Slope To Ensure Correct Drainage

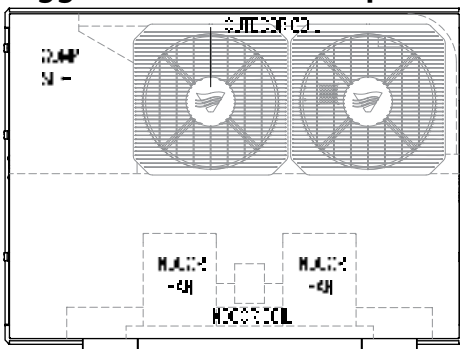

TOP VIEW

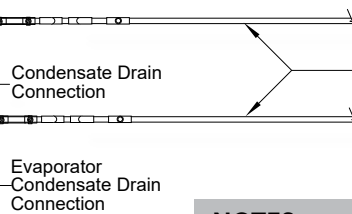

ENSURE DRAIN PIPE SLOPES DOWN FROM THE UNIT AT A MINIMUM OF 10MM PER METER. SEE SUGGESTED DRAIN TRAP DETAILS FOR REFERENCE.

NOTES

Condenser Drain must be run separately from the Evaporator Drain

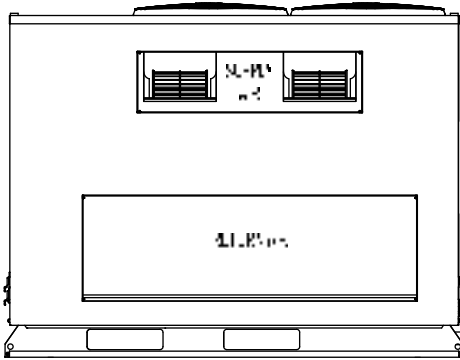

FRONT VIEW

ENSURE DRAIN PIPE SLOPES DOWN FROM THE UNIT AT A MINIMUM OF 10MM PER METER

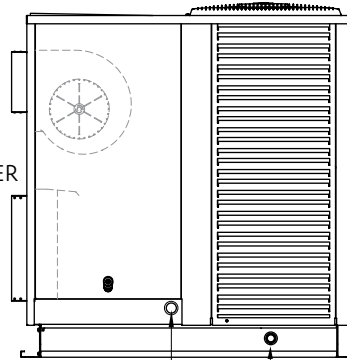
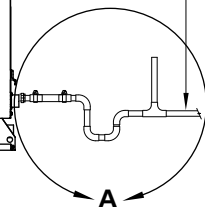

SIDE VIEW

SEAL CONNECTIONS WITH SILICON SEALANT

Suggested Drain Trap Details

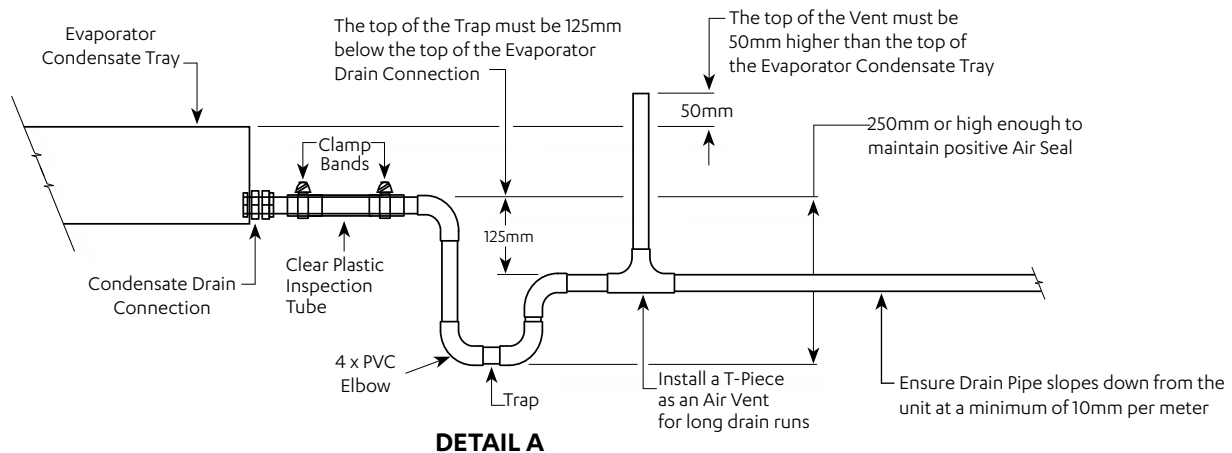

DETAIL A

Electrical Installation

All electrical work must be carried out by a qualified technician. Make sure all wiring is in accordance with local wiring rules. Wiring connections should be made in accordance with the wiring diagram provided in accordance with the latest edition of the AS/NZS 3000 "Australian / New Zealand Wiring Rules".

DANGER

Live Electrical Supply !

- During installation of your air conditioning unit, it may be necessary to work in close proximity to live electricity. Only qualified technicians are allowed to perform these tasks.
- Follow all electrical safety precautions when exposed to live electrical components.
- Always make sure that all power supply, including remote controls, are disconnected before performing maintenance. Observe proper LOCK-OUT / TAG-OUT (LOTO) procedures to ensure that power cannot be inadvertently energised. Failure to disconnect power before maintenance procedure can result in serious injury or death.
- All electrical wiring must be in accordance with the relevant electrical authority rules and regulations.

CAUTION

STATIC SENSITIVE ELECTRONIC DEVICES !

- DO NOT handle electronic devices unless you are wearing an Anti-Static Wrist Strap that is connected to a EARTH. Failure to protect the electronic devices from static electricity may cause unreparable damage.
- Static damaged electronic devices are NOT COVERED for replacement under warranty.

Wiring Diagram

The wiring diagrams specific for your air conditioning system are located on the inside of the electrical access panel.

Always refer all wiring installation, servicing and troubleshooting of this equipment to this diagram to ensure correct electrical connections are satisfied.

Supply and Power Requirements Procedure

It is the installer's responsibility to provide power supply wiring to the sub-mains isolator. Wiring should conform to the current electrical authority regulations and all wiring connections to be as per electrical diagram provided with the unit.

- Confirm that the power supply available is compatible with the unit nameplate ratings. The supply power must be within +6% to -6% of the rated voltage as per AS60335.1.
- Protect electrical service from over current and short circuit conditions in accordance with the latest edition of the AS/NZS 3000 "Australian / New Zealand Wiring Rules". Protection devices are to be sized accordingly as per to the electrical specifications of the unit.
- Complete the outdoor unit power supply wiring into the sub-mains isolator.
- Secure the power cords and control cables that enters in/exits out the unit. Use the cable ties provided in the electrical panels.
- Provide proper unit earthing in accordance with local and national wiring rules.
- Installer to connect an appropriate load break (AC3) isolator in sub mains wiring.

Compressor Voltage Balance Requirement

Check the voltage at the mains supply terminals to determine if it is balanced. Voltage imbalance on three phase systems can cause motor overheating and premature failure. The maximum allowable imbalance is + 2.0% should voltage imbalance exceed this value, check unit wiring connections to locate and rectify faults or contact local supply authority.

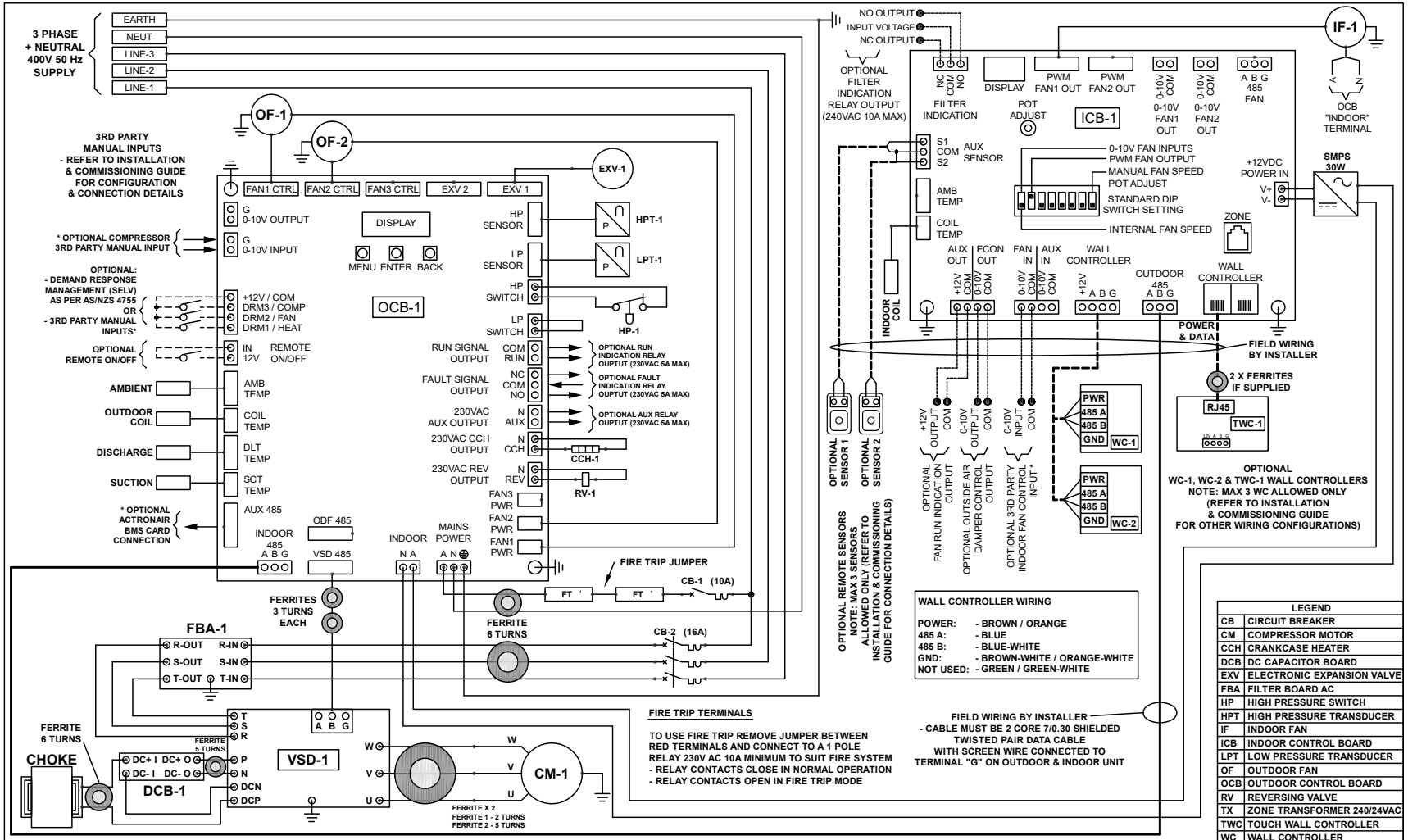

Installation and Commissioning Guide

Wiring Diagram

PRV15BT-T

| | | | | | | | | | | |
|------|-------------|------|----|------------|---|--|-----------------|--------------------------|---------------|----------------|
| A | New Release | 3881 | LC | 14/03/2025 | | Base Model No: PRV15BT | Variation Code: | Variation: STANDARD | | |
| | | | | | | Description: UNOPRO SERIES CONTROL SYSTEM WIRING DIAGRAM WITH CMI INDOOR BOARD & WALL CONTROL | | | | |
| Rev. | Description | PCR | By | Date | This drawing remains the intellectual property of Actron Engineering Pty Ltd. Reproduction, modification and/or distribution are prohibited without written consent. | Drawn: LC | 14/03/2025 | Drawing No: 0515-1119 | Sheet: 1/1 | Revision: A |
| | | | | | | Approved: JL | 14/03/2025 | | | |

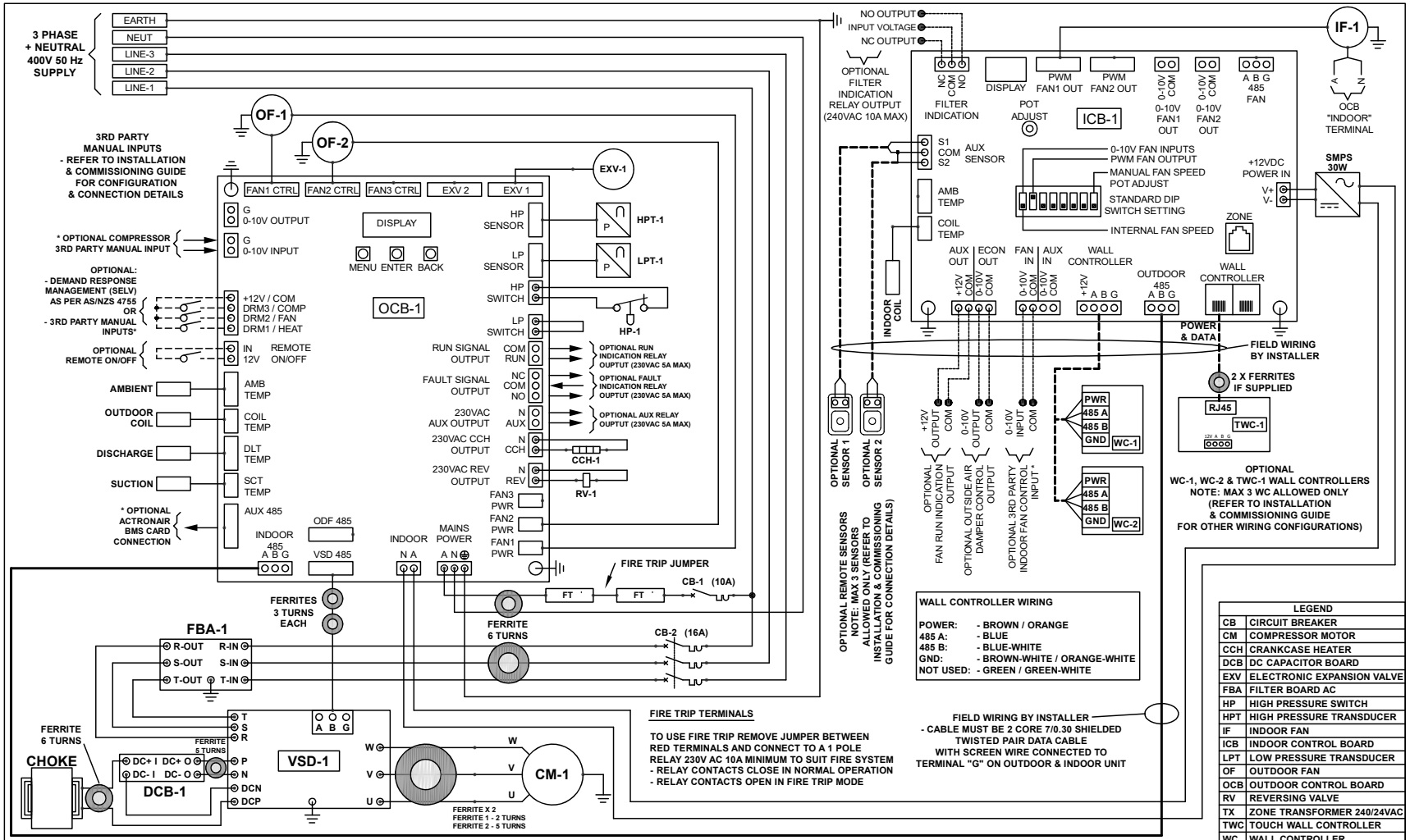

Installation and Commissioning Guide - Genesis Package Unit
Doc. No. 0525-147 Ver. 1 250408

| | | | | |
|------|-------------|------|----|------------|
| Rev. | Description | PCR | By | Date |
| A | New Release | 3881 | LC | 14/03/2025 |



| | | | | |
|----------------|--|-----------------|-------------|-----------|
| Base Model No: | PRV17BT | Variation Code: | Variation: | STANDARD |
| Description: | UNOPRO SERIES CONTROL SYSTEM WIRING DIAGRAM WITH CMI INDOOR BOARD & WALL CONTROL | | | |
| Drawn: | LC | 14/03/2025 | Drawing No: | 0515-1120 |
| Approved: | JL | 14/03/2025 | Sheet: | 1/1 |
| | | | Revision: | A |

This drawing remains the intellectual property of Actron Engineering Pty Ltd. Reproduction, modification and/or distribution are prohibited without written consent.

Electrical Connection

NOTES

- To minimise noise interference, Data and Power cable clearance should be maintained as much as possible.
- All drawings are for illustration purposes only. Actual unit may vary depending on the model.
- All electrical components do not come with the unit, must be purchased separately.
- All electrical work must be carried out by a qualified technician.
- Make sure all wiring is in accordance with local wiring rules.
- Wiring connections should be made in accordance with the provided wiring diagram. The unit wiring diagram is located in the Access Panel - Electrical.

Package Unit

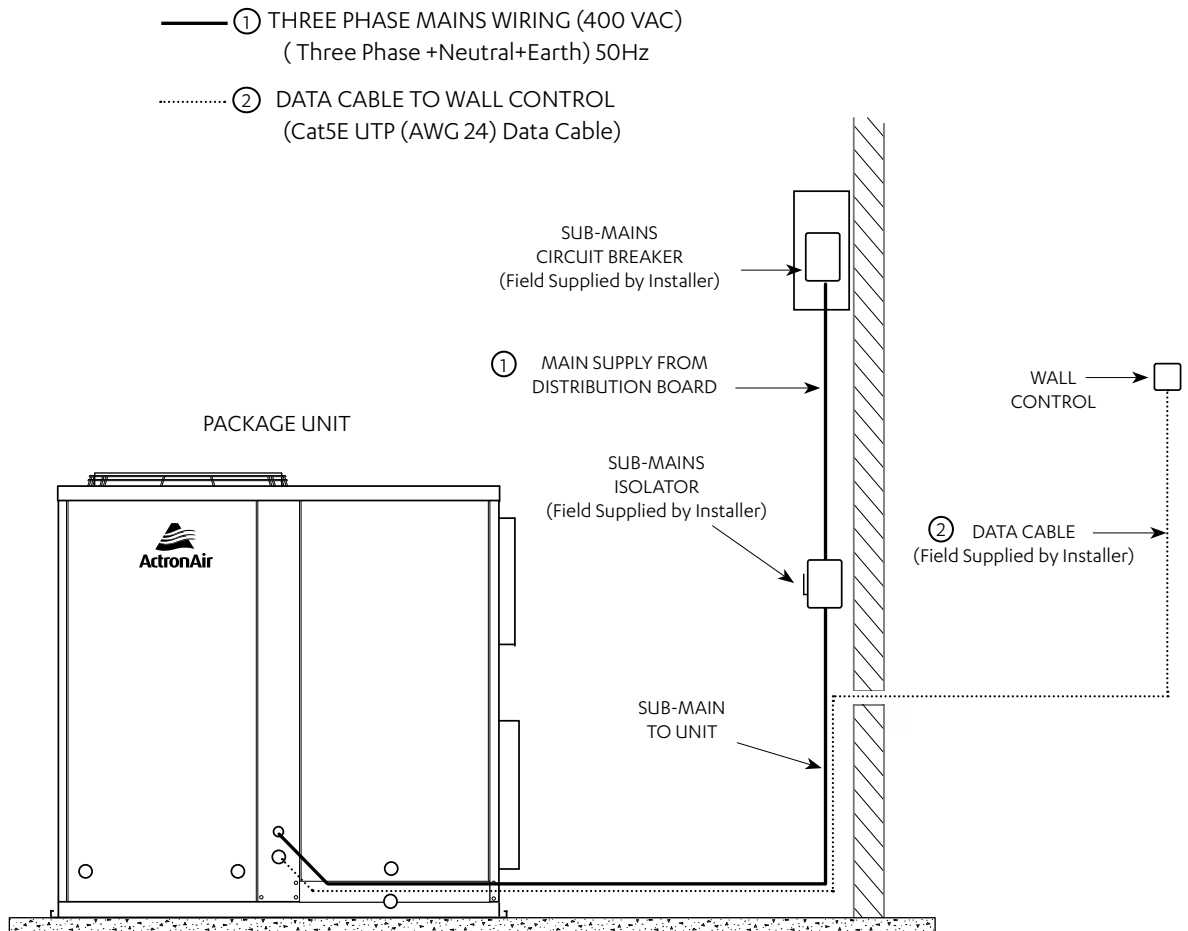

Circuit Breaker Size Recommendation

| Model | Circuit Breaker Size |
|---------|----------------------|
| | Amps |
| PRV15BT | 16A |
| PRV17BT | |

NOTE

Refer to latest edition of AS/NZS 3000 or AS/NZS 3008 Australian/New Zealand Wiring Rules to determine required cable size.

Wiring Connections

LC7-2 Wall Control Wiring Connections

WALL CONTROL WIRING

POWER: - BROWN / ORANGE
 485 A: - BLUE
 485 B: - BLUE-WHITE
 GND: - BROWN-WHITE / ORANGE-WHITE
 NOT USED: - GREEN / GREEN-WHITE

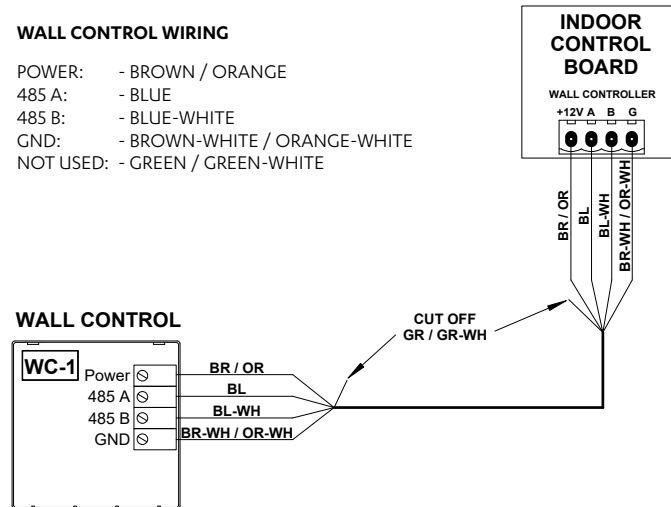

NEO Wall Control Wiring Connections

NOTES

Two FERRITE CLIPS, if supplied, should be installed 200 mm away and FERRITE 2 should be 400 mm away from the Wall Control.

NEO Hard Wiring

WALL CONTROL WIRING

POWER: - BROWN / ORANGE
 485 A: - BLUE
 485 B: - BLUE-WHITE
 GND: - BROWN-WHITE / ORANGE-WHITE
 NOT USED: - GREEN / GREEN-WHITE

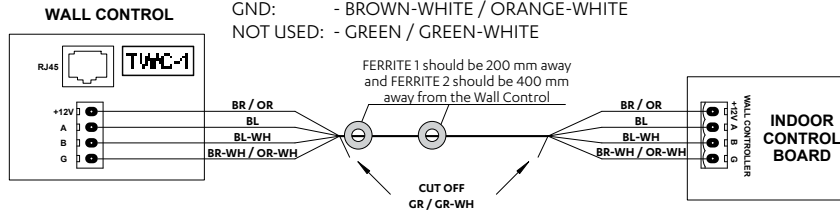

NEO RJ45 Wiring

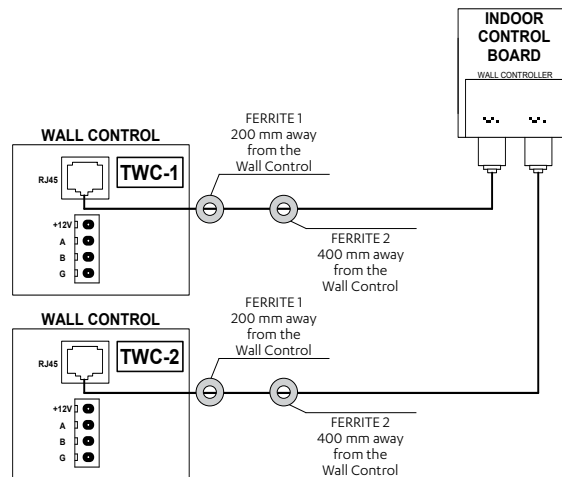

LM-RS-2 Optional Sensor Wiring Connections

REMOTE SENSOR WIRING

- PAIR 1: - BLUE / BLUE-WHITE
- PAIR 2: - ORANGE / ORANGE-WHITE
- PAIR 3: - GREEN / GREEN-WHITE
- PAIR 4: - BROWN / BROWN-WHITE

NOTE:

- PAIR 1 AND 2 USED FOR ILLUSTRATION PURPOSES ONLY.
- CUT OFF AND TERMINATE ANY UNUSED PAIRS TO ENSURE NO WIRING IS LEFT EXPOSED.

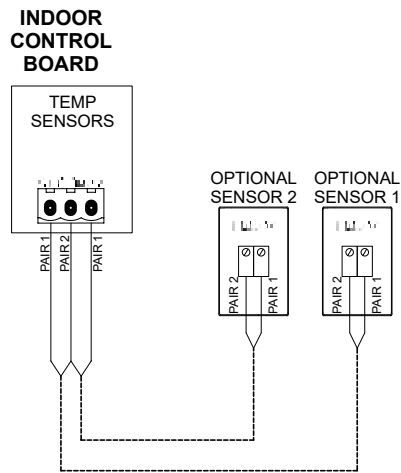

AERSS Optional Duct Sensor Wiring Connections

REMOTE SENSOR WIRING

- PAIR 1: - BLUE / BLUE-WHITE
- PAIR 2: - ORANGE / ORANGE-WHITE
- PAIR 3: - GREEN / GREEN-WHITE
- PAIR 4: - BROWN / BROWN-WHITE

NOTE:

- PAIR 1 AND 2 USED FOR ILLUSTRATION PURPOSES ONLY.
- CUT OFF AND TERMINATE ANY UNUSED PAIRS TO ENSURE NO WIRING IS LEFT EXPOSED.

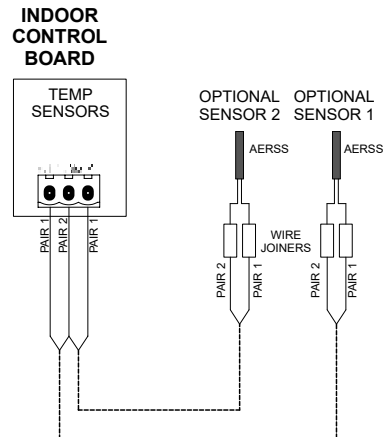

Configuring and Commissioning Setup

Menu and Navigation

| | | | |
|---------------------------------|--|--|--------------------------------|
| diS (Display) | Display system's status and settings | | |
| SEr (Service) | Service use only | | |
| SEt (Settings) | cnFg | 03.00 = Family* | |
| | | 03.00 = Capacity* | |
| | | Ct. | Ct. 0 = 3rd Party |
| | | | Ct. 1 = Wall Control (default) |
| | | | Ct. 2 = Basic BMS |
| | Ct. 3 = Wall Control + Basic BMS | | |
| | Ct. 4 = Advanced BMS | | |
| | CtrS | Ct. 0 = 3rd Party | |
| | | Ct. 1 = Wall Control (default) | |
| | | Ct. 2 = Basic BMS | |
| | | Ct. 3 = Wall Control + Basic BMS | |
| | | Ct. 4 = Advanced BMS | |
| | iduS | FP1 = IDU Fan Low PWM setting | |
| | | FP2 = IDU Fan Med PWM setting | |
| | | FP3 = IDU Fan High PWM setting | |
| | | Fr1 = IDU Fan Low RPM setting | |
| | | Fr2 = IDU Fan Med RPM setting | |
| | | Fr3 = IDU Fan High RPM setting | |
| | | FPd = IDU Fan Defrost PWM setting | |
| | | FPc = IDU Reduced Airflow PWM setting | |
| | | FIL = IDU Fan Filter Hours setting | |
| | | Econ = IDU Econ 0-10V Output setting | |
| | FnSE = Indoor Fan Setting | | |
| | SoFt | no = Soft Start not enabled (default) | |
| | | YES = Soft Start enabled | |
| | run | no = Indoor Fan and Compressor (default) | |
| | | YES = Compressor only | |
| | odFS | Pc = Pressure control | |
| | | tc = Temperature control | |
| | | CrS = Cooling rated speed. | |
| | | CHS = Cooling max. speed. | |
| | | CtrS = Temp. restricted speed. | |
| | | Crt1 = Cooling restricted temp. | |
| | | Crt2 = Cooling restricted temp. | |
| | | Crt3 = Cooling restricted temp. | |
| | | HrS = Heating rated speed. | |
| | | HHS = Heating max. speed. | |
| | | HtrS = Heating temp. restricted speed. | |
| | | Hrt1 = Heating restricted temp. | |
| | | Hrt2 = Heating restricted temp. | |
| Hrt3 = Heating restricted temp. | | | |
| qS | | CCS = Cooling compressor speed | |
| | HCS = Heating compressor speed | | |
| | CCt = Cooling mode critical temp condition | | |
| | HCT = Heating mode critical temp condition | | |

Continuation of SEt (Settings)

| | |
|--------|--|
| EEU | SEEU = Single EEV |
| | dEEU = Double EEV |
| **EEUt | tE1 = UKV Type (Versions 0100) |
| | tE2 = UKV-SE Type (Versions 0200) |
| | tE3 = DPF-TS11 Type (B Series) - Default |

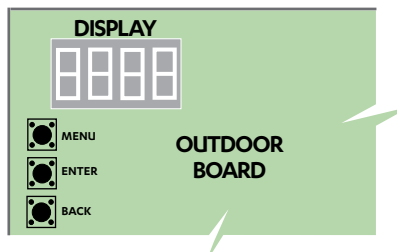

MENU Scroll through the items at the same menu level.

Increment the value being set.

ENTER Go into the selected menu. Lock in selected value.

BACK Go back to the parent menu. Press and hold to go back to main menu.

* Family and Capacity are the representative values only and may vary depend on the model purchased as seen below table. **Do not change setting.**

| Model | | PRV15BT-T | PRV17BT-T |
|--------|-------------|---------------|-----------|
| Family | Family Name | Capacity (kW) | |
| 11 | Genesis | 15 | 17 |

Configuring Compressor and Capacity(cnFg)

Configure the compressor type and capacity. The unit is factory configured. **Do not change this setting.**

Configuring Control Source (CtrS)

This commissioning is applicable for BMS and third party control.

Configurable settings are as follows:

Third Party Control

The unit can be controlled by non-ActronAir wall control. To do this, **CtrS** on the Outdoor Board has to be set to **Ct. 0**. For connection details, see the wiring diagram supplied with the outdoor unit.

Wall Control

ActronAir offers NEO, LR7-1 and LC7-2, wall controls that can control the available features and maximise the function and operation of the air conditioner. To do this, **CtrS** on the Outdoor Board must be set to **Ct. 1**.

Basic BMS

The unit can be connected to a network through a BMS card (ICUNO-MOD). This allows the unit to be operated in the same way the as the NEO, LR7-1 and LC7-2 does. To do this, **CtrS** on the Outdoor Board must be set to **Ct. 2**.

Wall Control + Basic BMS

The unit can be connected to a network (Basic BMS) and at the same time be controlled using the NEO, LR7-1 or LC7-2 controller. Priority will be given to the most recent command. To do this, **CtrS** on the Outdoor Board must be set to **Ct. 3**.

Advanced BMS

The unit can be connected for system that requires customised functions not included in the existing software or logic in the Outdoor Board but still retaining the safety logic. To do this, **CtrS** on the Outdoor Board must be set to **Ct. 4**.

Demand Response Management

These products are compliant to AS/NZS 4577.3.1:2012

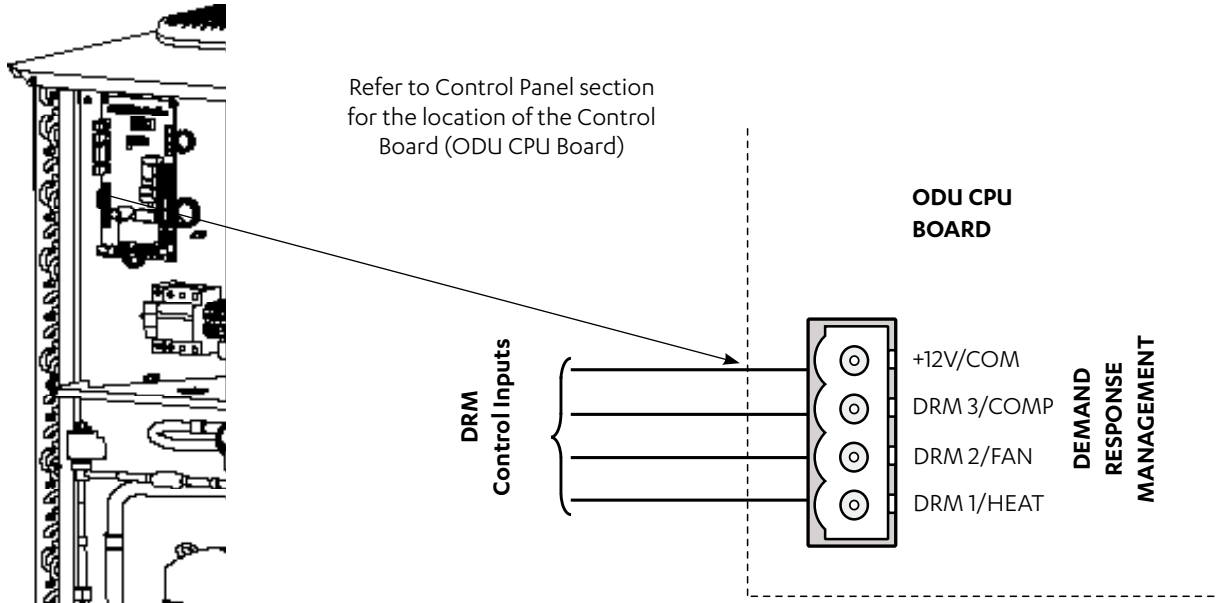

1. Route DRM input cables into the Unit (as per previous wiring installation procedure).
2. Connect cables into terminals (as per wiring diagram provided with the unit).

| Demand Management Mode | Description Of Mode Allowable Range (%) | Operating Mode |
|------------------------|---|---|
| DRM1 | Compressor Off Mode | Compressor <u>ONLY</u> will cycle Off and remain Off for the entire Demand Response event. All other functions will operate as normal (i.e. Indoor Fan) |
| DRM2 | Maximum 50% power use mode with 0 to <50% allowable power use range | Compressor 0 to <50% operation range for the total Demand Response event. |
| DRM3 | Maximum 75% power use mode with 0 to <75% allowable power use range | Compressor 0 to <75% operation range for the total Demand Response event. |

DEMAND RESPONSE ENABLING DEVICE CIRCUIT DIAGRAM

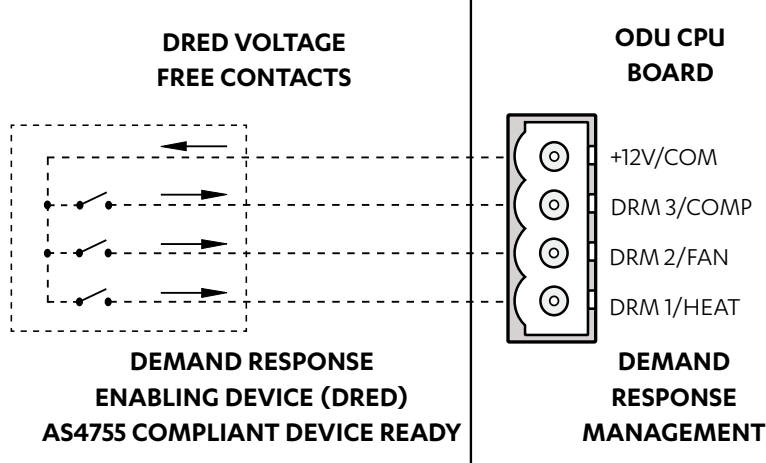

NOTES

- Demand Response Management is not applicable when using third party control.
- Contact your electricity authority to install and activate DRED.
- All drawings are for illustration purposes only. Actual unit may vary depending on the model.

Third Party Control Input (Indoor and/or Outdoor Board)

This option allows Fan, Compressor and Reversing Valve to be controlled by a Third Party Control. There are two ways on how the Indoor Fan may be controlled, using 0-10V Analogue Input or Fixed Indoor Fan Speed.

NOTE

- Demand Response Management (DRM) is not available if Third Party Control Option is used.
- Ensure control source has been configured for Control Mode 0.
 1. On the Outdoor Board, set Control Source to Third Party. Using the MENU and the ENTER buttons, navigate to SEt (Settings) --> CtrS (Control Source).
 2. Use the MENU button to navigate to 0 to select Third Party Control as the control source. Press the ENTER button to save the setting.

0-10V Analogue Input for Compressor and Indoor Fan

Indoor Fan Connection (Indoor Board)

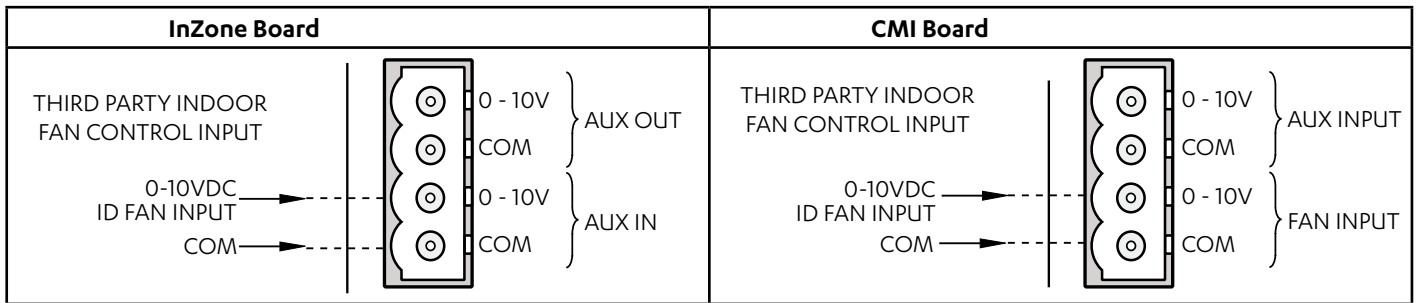

Indoor Fan Setting (Indoor Board)

| InZone Board | CMI Board |
|---------------------------------|---|
| No additional setting required. | On the indoor board ensure dip switch ONE and TWO are ON . |
| | <p>ON</p> <p>OFF</p> <p>1 2 3 4 5 6 7 8</p> |

| Input (DC) | Output | Fan Status |
|----------------|-------------|------------|
| 0.0V to 0.99 V | 0% | Off |
| 1.0V to 1.49 V | 0 or 20% | Off or On |
| 1.5V to 9.5 V | 20% to 100% | On |
| 9.5V to 10 V | 100% | On |

Compressor and Reversing Valve Connection (Outdoor Board)

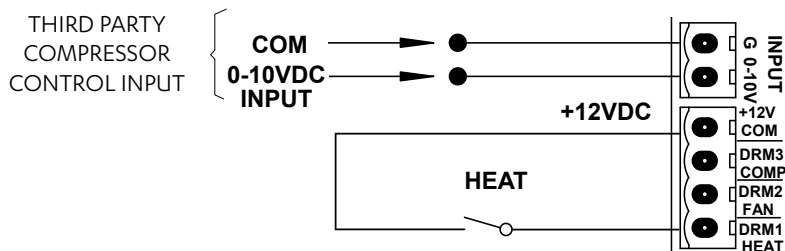

| Input (DC) | Output | Compressor Status |
|-------------|-------------|---------------------|
| 0 - 0.99 V | 0% | Off |
| 1 - 1.49 V | 0 or 20% | Off/On (hysteresis) |
| 1.5 - 9.5 V | 20% to 100% | On |
| 9.5 - 10 V | 100% | On |

NOTES

- As the compressor turns ON and the Indoor fan signal is not available then indoor fan will start to run on medium PWM speed.
- Indoor fan low and high PWM limits depends upon the model. Refer to Indoor Fan Table and Fan Curve Section.
- The Voltage can be linearly interpolated using the above table to determine the desired PWM or unit output.
- Only applicable for CMI board: If the compressor turn ON, during reduced fan operation, the controller will increase the fan speed to the "low PWM fan limit" if it is running less than the low PWM Limits.

0-10V Analogue Input for Compressor with Fixed Indoor Fan Speed

This feature allows for the Indoor Fan to be controlled externally (ON/OFF only).

Indoor Fan Connection (Indoor Board) AS IS

When using fixed speed indoor fan, there would be no wiring onto the InZone nor CMI.

Indoor Fan Setting (Indoor Board)

| InZone Board | CMI Board |
|---------------------------------|--|
| No additional setting required. | On the indoor board ensure that only dip switch TWO is ON . |

Fan, Compressor and Reversing Valve Connection (Outdoor Board)

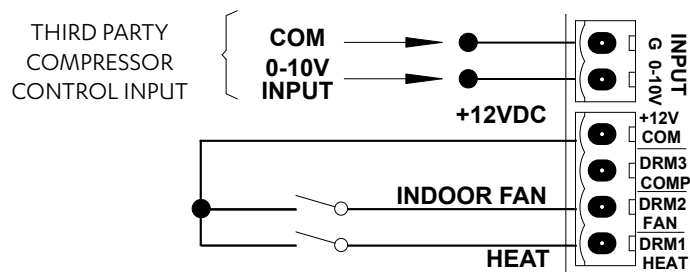

NOTES

- As the compressor turns ON and the Indoor fan signal is not available then indoor fan will start to run on medium PWM speed.
- Indoor fan operation when fan signal is available:
 - Compressor ON : Indoor fan will run on medium speed.
 - Compressor OFF :
 - » CMI: Indoor fan will run on reduce airflow operation.
 - » InZone: Indoor fan is dependent of the controller setting.

Input for Fixed Compressor with Fixed Indoor Fan Speed

This feature allows for both Compressor and Indoor Fan to be controlled externally (ON/OFF only).

Indoor Fan Setting (Indoor Board)

| InZone Board | CMI Board |
|---------------------------------|--|
| No additional setting required. | On the indoor board ensure that only dip switch TWO is ON . |
| | <p>ON</p>  <p>OFF</p> |

Fan, Compressor and Reversing Valve Connection (Outdoor Board)

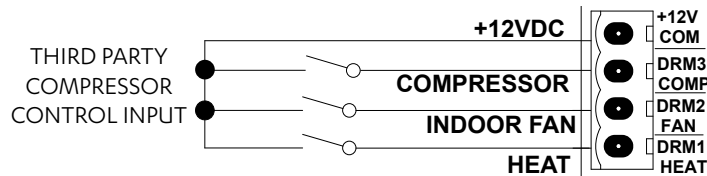

NOTES

- As the compressor turns ON and the Indoor fan signal is not available then indoor fan will start to run on medium PWM speed.
- Indoor fan operation when fan signal is available:
 - Compressor ON : Indoor fan will run on medium speed.
 - Compressor OFF :
 - » CMI: Indoor fan will run on reduce airflow operation
 - » InZone: Indoor fan is dependent of the controller setting.
- Compressor turns on with 100% speed request.
- Although the compressor will have 100% speed request, the speed may vary depending on compressor safety requirements. This will be shown on the outdoor board display.

0-10V Analogue Input for Indoor Fan with Fixed Speed Compressor

This feature allows for the compressor to be controlled externally (ON/OFF only).

Indoor Fan Connection (Indoor Board)

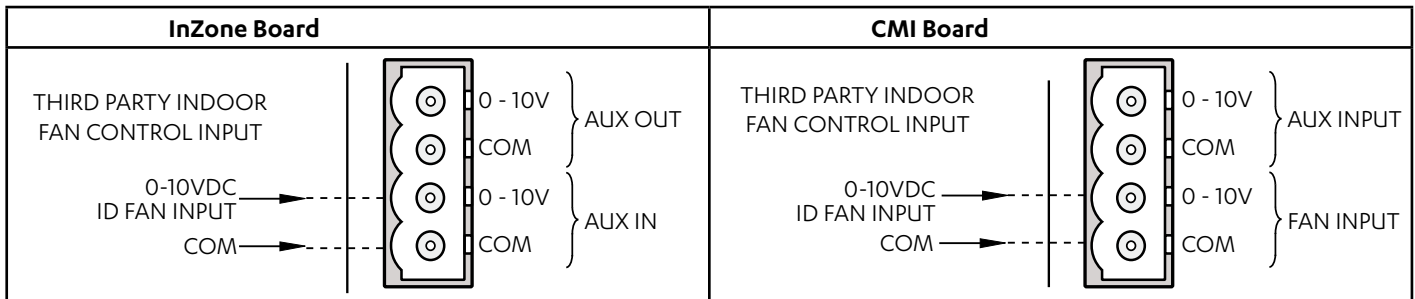

Indoor Fan Setting (Indoor Board)

| InZone Board | CMI Board |
|---------------------------------|--|
| No additional setting required. | On the indoor board ensure dip switch ONE and TWO are ON . |
| | <p>ON</p>  <p>OFF</p> |

| Input (DC) | Output | Fan Status |
|-----------------|-------------|------------|
| 0.0 V to 0.99 V | 0% | Off |
| 1.0 V to 1.49 V | 0 or 20% | Off or On |
| 1.5 V to 9.5 V | 20% to 100% | On |
| 9.5 V to 10 V | 100% | On |

Fan, Compressor and Reversing Valve Connection (Outdoor Board)

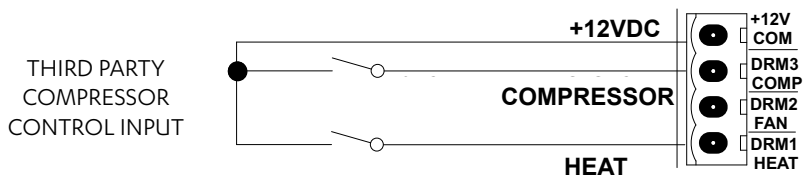

NOTES

- As the compressor turns ON and the Indoor fan signal is not available then indoor fan will start to run on medium PWM speed.
- If the compressor turn ON, during reduced fan operation, the controller will increase the fan speed to the "low PWM fan limit" if it is running less than the low PWM Limits.
- Indoor fan low and high PWM limits depends upon the model.
- The Voltage can be linearly interpolated using the above table to determine the desired PWM or unit output.
- Compressor turns on with 100% speed request.

Run and Fault Indication Output (Outdoor Board)

To activate, the unit must be wired as illustrated below. If required, a fault output connection terminal is also available to show any error/fault with the a/c system. RUN/FAULT relay outputs (230VAC/5A MAX) connection.

Run Indication

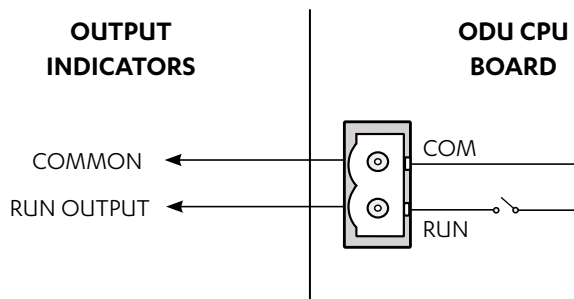

Run Output is configurable to indicate that the unit is running. There are two configurations in which this can be set:

- Either the compressor or the Indoor Fan only is running
- Only Compressor is running.

By default, this is set to turn on when either indoor fan or compressor is operating. To set up to compressor run indication only, in OD Board Menu follow below steps.

1. Using the **MENU** and the **ENTER** Buttons on the outdoor PCB, navigate to **Set** (Settings) → **run** (Unit Operation Indicator Settings).
2. If required, press **MENU** to navigate to **YES**.

Fault Indication

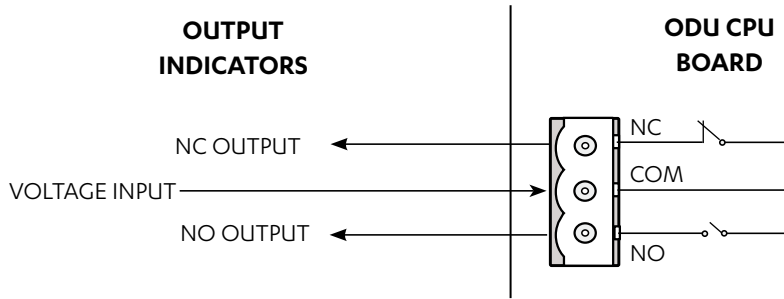

To indicate any system fault, outdoor controller will provide a signal through the Fault Indication relay. An installer can use either NC or NO output as per their requirements.

Remote On/Off

To activate, the unit must be wired as illustrated below. This will enable unit to be turned ON and OFF from the Outdoor board.

NOTES

The system must be operating in Wall Controller only (control mode 1) or BMS + Wall Controller (control mode 3) for this function to work.

1. On the Outdoor Board, set Control Source to Third Party. Using the MENU and the ENTER buttons, navigate to SEt (Settings) --> CtrS (Control Source).
2. Use the MENU button to navigate to "1" or "3" to select "Wall Controller only" or "BMS + Wall Controller" as the control source. Press the ENTER button to save the setting.

Turning the system On and Off by remote method

| | |
|------------------------|---|
| Turning the system On | Status 1: The system is Off and the remote switch/relay has been left in the open position. 1. Close remote switch/relay. 2. System will start in approximately in 30 seconds. |
| | Status 2: The system is Off and the remote switch/relay has been left in the closed position. 1. Open remote switch/relay for a minimum of 5 seconds. 2. Close remote switch/relay. 3. System will start in approximately in 30 seconds. |
| Turning the system Off | Status 3: The system is On and the remote switch/relay has been left in the closed position. 1. Open remote switch/relay. 2. System will turn Off in approximately in 30 seconds. |
| | Status 4: The system is On and the remote switch/relay has been left in the open position. 1. Close remote switch/relay for a minimum of 5 seconds. 2. Open remote switch/relay. 3. System will turn Off in approximately in 30 seconds. |

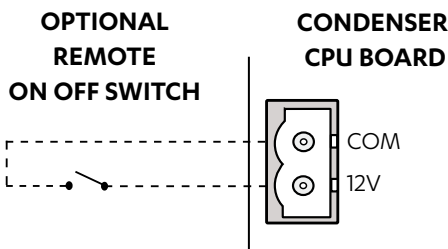

Indoor Fan Commissioning

PRV15BT

FAN DATA*

| AIRFLOW (l/s) | EXTERNAL STATIC PRESSURE (Pa) | | | | | | | | | |
|------------------|-------------------------------|-----|-----------|------------|-------|-----|----------------------|-----|-------|-----|
| | 50 | | 100 | | 150 | | 200 | | 250 | |
| | % PWM | W | % PWM | W | % PWM | W | % PWM | W | % PWM | W |
| 620 | 41 | 164 | 48 | 224 | 55 | 288 | 62 | 376 | 67 | 458 |
| 650 | 45 | 180 | 52 | 244 | 58 | 310 | 63 | 386 | 71 | 480 |
| 675 | 48 | 196 | 55 | 261 | 61 | 336 | 65 | 411 | 75 | 501 |
| 700 | 51 | 211 | 58 | 280 | 63 | 357 | 67 | 419 | 96 | 545 |
| 725 | 55 | 238 | 61 | 306 | 64 | 360 | 69 | 434 | | |
| 750 | 58 | 255 | 62 | 309 | 67 | 390 | 72 | 456 | | |
| 770 | 60 | 261 | 64 | 324 | 69 | 396 | 75 | 479 | | |
| 775 | 60 | 263 | 64 | 327 | 69 | 397 | 76 | 485 | | |
| 800 | 62 | 282 | 67 | 352 | 73 | 432 | 80 | 510 | | |
| 825 | 64 | 297 | 70 | 371 | 76 | 452 | 87 | 539 | | |
| 850 | 67 | 321 | 74 | 407 | 80 | 480 | MOTOR / BLOWER LIMIT | | | |
| 875 | 71 | 352 | 78 | 437 | 84 | 511 | | | | |
| 900 | 75 | 382 | 81 | 456 | 90 | 547 | | | | |
| 920 | 77 | 397 | 84 | 486 | | | | | | |

REDUCED AIRFLOW** (COMPRESSOR OFF)

| AIRFLOW (l/s) | EXTERNAL STATIC PRESSURE (Pa) | | | | | | | | | |
|------------------|-------------------------------|-----|-------|-----|-------|-----|-------|-----|-------|-----|
| | 50 | | 100 | | 150 | | 200 | | 250 | |
| | % PWM | W | % PWM | W | % PWM | W | % PWM | W | % PWM | W |
| 260 | 14 | 46 | 19 | 84 | 24 | 118 | 28 | 152 | 33 | 195 |
| 275 | 15 | 48 | 20 | 86 | 25 | 124 | 29 | 159 | 34 | 202 |
| 300 | 17 | 60 | 22 | 97 | 27 | 136 | 31 | 171 | 35 | 209 |
| 325 | 18 | 64 | 23 | 99 | 28 | 138 | 33 | 183 | 38 | 229 |
| 350 | 19 | 68 | 25 | 108 | 30 | 148 | 35 | 193 | 40 | 237 |
| 375 | 20 | 70 | 27 | 117 | 32 | 159 | 37 | 207 | 41 | 252 |
| 400 | 23 | 84 | 29 | 126 | 35 | 177 | 39 | 220 | 45 | 277 |
| 425 | 24 | 86 | 31 | 136 | 37 | 189 | 42 | 240 | 49 | 303 |
| 450 | 26 | 95 | 34 | 151 | 39 | 200 | 45 | 256 | 52 | 318 |
| 475 | 28 | 104 | 36 | 161 | 42 | 216 | 48 | 279 | 52 | 328 |
| 500 | 30 | 111 | 37 | 164 | 45 | 231 | 51 | 296 | 56 | 351 |
| 525 | 32 | 119 | 39 | 176 | 47 | 244 | 53 | 307 | 58 | 367 |
| 600 | 39 | 152 | 46 | 210 | 54 | 287 | 61 | 369 | 65 | 437 |

NOTES

* Above Fan Data table is only applicable only to Third Party Controller

** Reduced fan airflow is the airflow during compressor OFF operation (optional feature)

W = Indoor Fan Power, Watts

PWM = Pulse Width Modulation Setting, 73% PWM (Adjustable through the LC7-2, NEO or Outdoor Board).

| Default Fan Speed Value at 100 Pa | |
|-----------------------------------|--------------------------|
| Speed | Default PWM (adjustable) |
| High PWM (%) | 84 |
| Medium PWM (%) | 64 |
| Low PWM (%) | 48 |

| Indoor Fan PWM Limits | |
|-----------------------|----|
| High PWM Limit (%) | 99 |
| Low PWM Limit (%) | 41 |

PRV15BT : Third Party Application Fan Curve

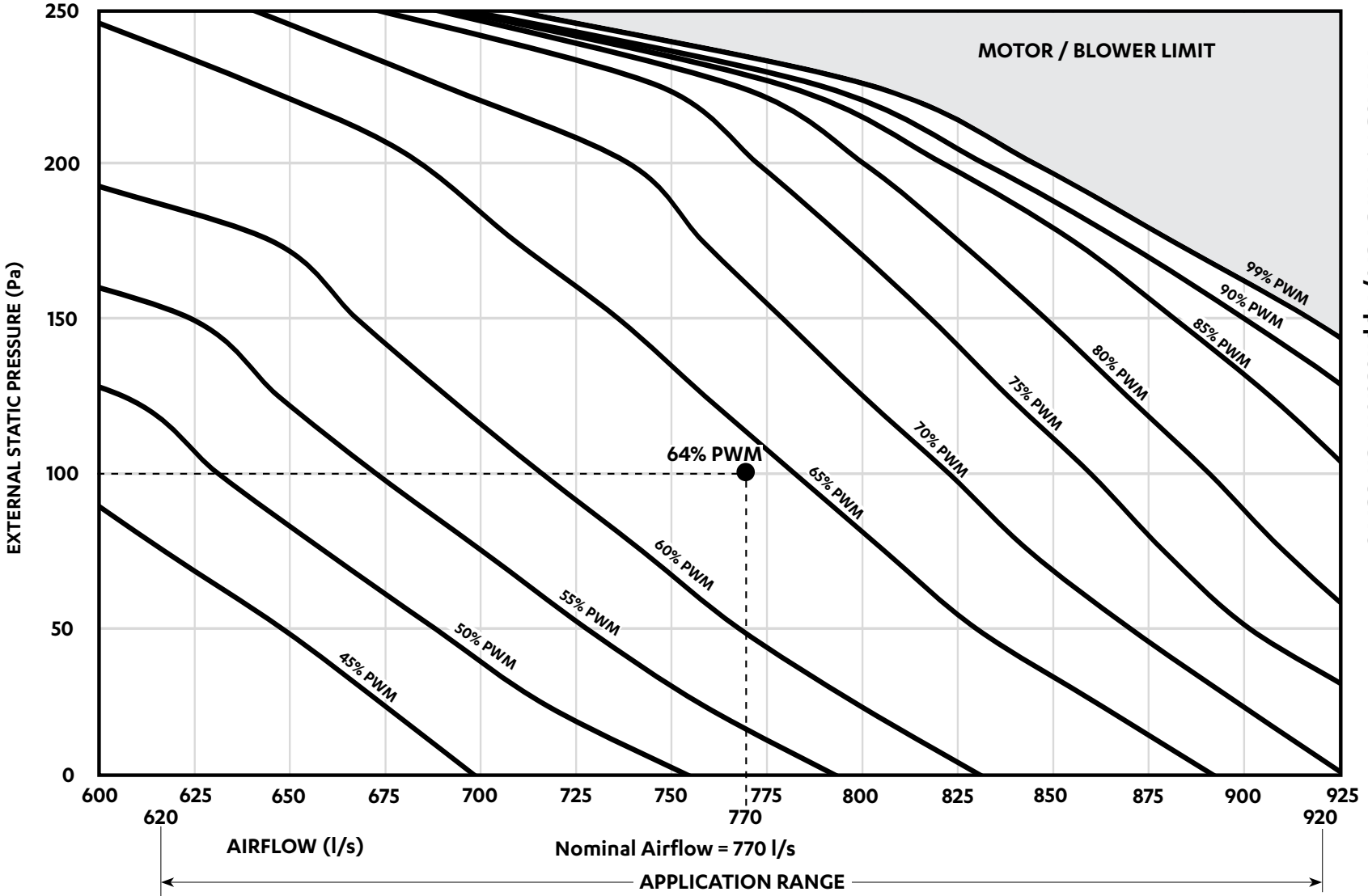

NOTE

Fan Performance Data and Fan Curve shown is at dry coil and with no air filters installed. Consider external static pressure drop specific to your design requirements. Airflow should be reduce with respect to the moisture content in the air. Please review filter manufacturer for application. 2.5 m/s face velocity point will occur outside the application range.

**PRV17BT
FAN DATA***

| AIRFLOW (l/s) | EXTERNAL STATIC PRESSURE (Pa) | | | | | | | | | |
|------------------|-------------------------------|-----|-----------|------------|-------|-----|-------|-----|----------------------|-----|
| | 50 | | 100 | | 150 | | 200 | | 250 | |
| | % PWM | W | % PWM | W | % PWM | W | % PWM | W | % PWM | W |
| 710 | 46 | 185 | 52 | 247 | 58 | 317 | 64 | 397 | 70 | 468 |
| 725 | 48 | 196 | 54 | 259 | 60 | 330 | 66 | 411 | 72 | 485 |
| 750 | 50 | 202 | 57 | 279 | 63 | 355 | 69 | 433 | 76 | 502 |
| 775 | 53 | 220 | 60 | 299 | 66 | 378 | 72 | 453 | 90 | 534 |
| 800 | 56 | 237 | 62 | 308 | 69 | 401 | 75 | 477 | MOTOR / BLOWER LIMIT | |
| 825 | 59 | 255 | 65 | 328 | 72 | 422 | 80 | 503 | | |
| 850 | 62 | 273 | 68 | 349 | 75 | 444 | 87 | 534 | | |
| 875 | 65 | 293 | 72 | 382 | 79 | 471 | 99 | 555 | | |
| 890 | 67 | 303 | 73 | 395 | 81 | 485 | | | | |
| 900 | 68 | 310 | 75 | 403 | 83 | 495 | | | | |
| 925 | 71 | 328 | 78 | 419 | 88 | 523 | | | | |
| 950 | 75 | 360 | 82 | 446 | 95 | 552 | | | | |
| 975 | 78 | 377 | 87 | 480 | | | | | | |
| 1000 | 82 | 404 | 92 | 509 | | | | | | |
| 1025 | 87 | 438 | | | | | | | | |
| 1050 | 92 | 467 | | | | | | | | |
| 1060 | 95 | 487 | | | | | | | | |

REDUCED AIRFLOW (COMPRESSOR OFF)**

| AIRFLOW (l/s) | EXTERNAL STATIC PRESSURE (Pa) | | | | | | | | | |
|------------------|-------------------------------|-----|-------|-----|-------|-----|-------|-----|-------|-----|
| | 50 | | 100 | | 150 | | 200 | | 250 | |
| | % PWM | W | % PWM | W | % PWM | W | % PWM | W | % PWM | W |
| 300 | 15 | 47 | 19 | 80 | 24 | 120 | 28 | 156 | 33 | 202 |
| 325 | 16 | 52 | 21 | 91 | 26 | 131 | 30 | 167 | 35 | 212 |
| 350 | 17 | 56 | 22 | 94 | 27 | 134 | 32 | 178 | 37 | 222 |
| 375 | 19 | 67 | 24 | 104 | 29 | 145 | 34 | 193 | 38 | 232 |
| 400 | 20 | 70 | 26 | 114 | 31 | 156 | 36 | 205 | 40 | 248 |
| 425 | 22 | 79 | 27 | 116 | 33 | 168 | 37 | 207 | 42 | 260 |
| 450 | 23 | 80 | 29 | 126 | 35 | 178 | 39 | 219 | 44 | 271 |
| 475 | 25 | 88 | 31 | 135 | 37 | 190 | 41 | 231 | 46 | 288 |
| 500 | 27 | 97 | 33 | 145 | 39 | 201 | 44 | 255 | 49 | 310 |
| 525 | 29 | 105 | 35 | 155 | 41 | 212 | 46 | 266 | 51 | 327 |
| 550 | 31 | 114 | 37 | 165 | 43 | 223 | 48 | 279 | 53 | 338 |
| 575 | 33 | 122 | 39 | 174 | 45 | 233 | 50 | 290 | 55 | 355 |
| 600 | 35 | 129 | 42 | 193 | 47 | 245 | 53 | 315 | 58 | 378 |
| 625 | 38 | 147 | 44 | 203 | 50 | 265 | 55 | 326 | 60 | 386 |
| 650 | 40 | 154 | 46 | 212 | 52 | 276 | 58 | 351 | 63 | 417 |
| 675 | 42 | 162 | 49 | 231 | 55 | 298 | 60 | 363 | 65 | 431 |
| 700 | 45 | 178 | 51 | 239 | 57 | 309 | 63 | 388 | 68 | 457 |
| 725 | 48 | 196 | 54 | 259 | 60 | 330 | 66 | 411 | 72 | 485 |

NOTES

- * Above Fan Data table is only applicable only to Third Party Controller
- ** Reduced fan airflow is the airflow during compressor OFF operation (optional feature)
- W = Indoor Fan Power, Watts
- PWM = Pulse Width Modulation Setting, 73% PWM (Adjustable through the LC7-2, NEO or Outdoor Board).

| Default Fan Speed Value at 100 Pa | |
|-----------------------------------|--------------------------|
| Speed | Default PWM (adjustable) |
| High PWM (%) | 92 |
| Medium PWM (%) | 73 |
| Low PWM (%) | 52 |

| Indoor Fan PWM Limits | |
|-----------------------|----|
| High PWM Limit (%) | 99 |
| Low PWM Limit (%) | 46 |

PRV17BT : Third Party Application Fan Curve

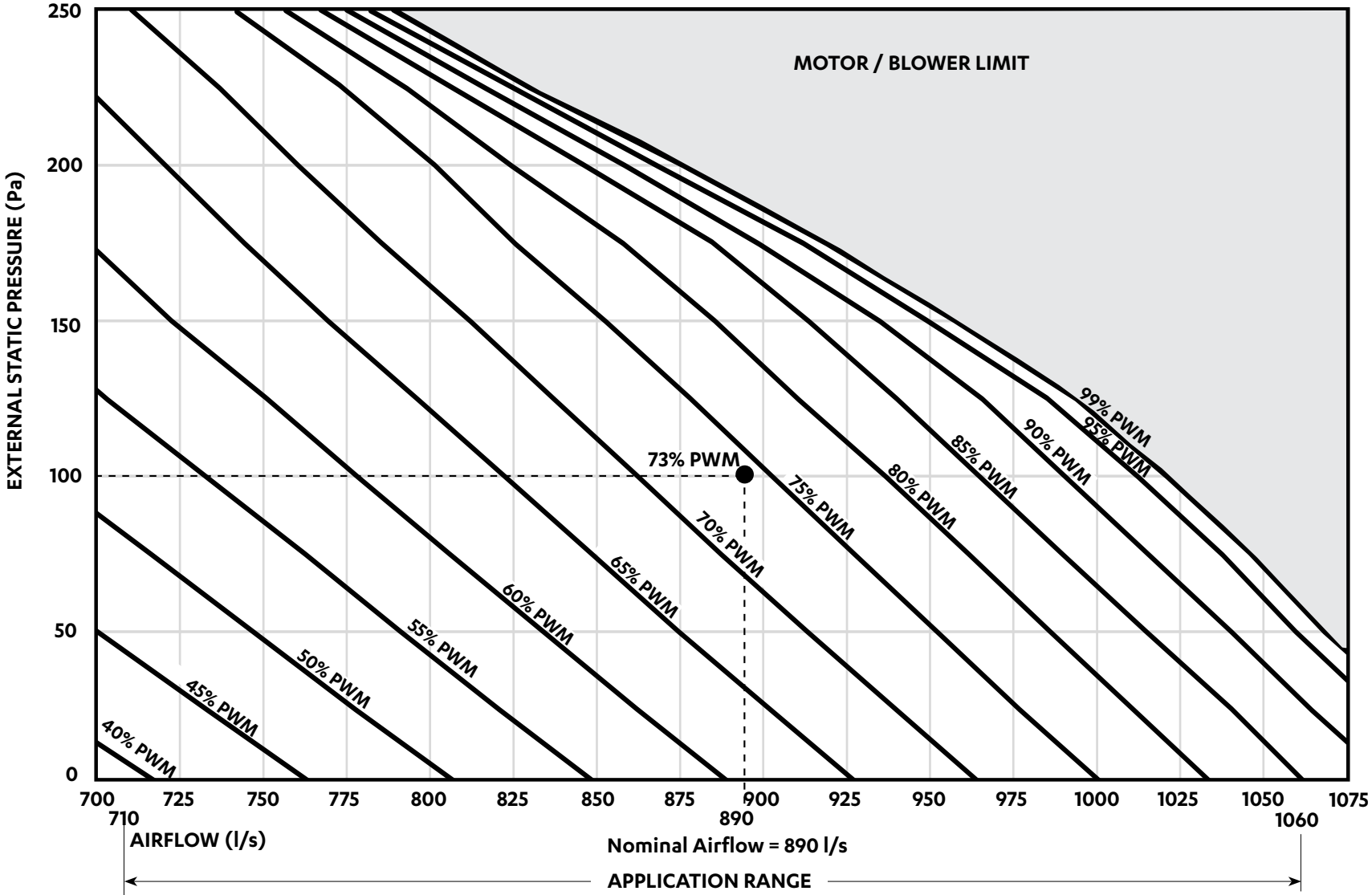

NOTE

Fan Performance Data and Fan Curve shown is at dry coil and with no air filters installed. Consider external static pressure drop specific to your design requirements. Airflow should be reduce with respect to the moisture content in the air. Please review filter manufacturer for application. 2.5 m/s face velocity point will occur outside the application range.

Refrigerant Charging

- The unit is supplied with factory charged refrigerant as stated in the Rating Label. The use of other material as a refrigerant may cause explosion and/or personal injury.
- Be aware of all the relevant regulations concerning the handling of refrigerant.
- The refrigeration system operates with Polyester (POE-46)* oil.
- It is important to work with absolute cleanliness.
- Brazing must be done with the use of Nitrogen to avoid carbon deposits into the pipes.
- The system must be evacuated thoroughly to 500 microns (see evacuation procedure).
- Never allow refrigerant to vent into the atmosphere. It is an offence to release refrigerant in Australia.
- Always reclaim refrigerant using equipment and container dedicated for the refrigerant used in the system.
- Only qualified technicians are allowed to perform any work described in this guide.
- All work must be carried out in accordance with Australia and New Zealand refrigerant handling code of practice.

CAUTION

*POE-46 oil that rapidly absorbs moisture. The maximum time any system can be opened to atmosphere is 15 minutes. This unit is charged with R-32 refrigerant.

- R-32 refrigerant (CLASS A2L) is mildly flammable. Thoroughly read and understand the accompanying R-32 Safety Guide for installation and maintenance instructions.
- R-32 refrigerant is odorless if the refrigerant gas comes into contact with fire, it may emit a poisonous gas.
- Installation, service, maintenance, repairs and decommissioning of this unit must be performed by a licensed HVAC technician; qualified to handle R-32 refrigerant.
- Appliance shall be installed, operated and stored in a well ventilated area:
 - away from other potential continuously operating sources that known to cause ignition of R-32 refrigerant.
 - where the room size corresponds to the room area as specific for operation.
 - without continuously operating open flames (for example an operating gas appliance) and ignition sources (for example an operating electric heater).

| REFRIGERANT CHARGE DETAILS (R-32) | |
|-----------------------------------|------------------------|
| Model | Refrigerant Charge (g) |
| PRV15BT-T | 2450 |
| PRV17BT-T | 2730 |

Charging Method: Subcooling and Superheat

Parameters:

LLT = Liquid Line Temperature

SLT = Suction Line Temperature

SCT = Saturated Condensing Temperature

SST = Saturated Suction Temperature

Cooling and Heating Operation:

Adjust the refrigerant charge to obtain the correct super heat and sub-cool for optimal performance as follows:

1. Ensure that air filters are fitted and total system airflows are achieved. (Air filters are not supplied with the unit, it is the responsibility of the installing contractor to provide and fit adequate return air and fresh air filters).
2. Connect service gauges to the shut off valves.
3. Start the unit in cool mode ensuring that the compressor is in operation before taking service gauges reading. Allow the system to stabilise for next 15 - 30 minutes before recording.
4. Record the discharge pressure, suction pressure, liquid line temperature and suction line temperature for all the refrigeration circuits.

Discharge Pressure = _____ kPa

Suction Pressure = _____ kPa

Liquid Line Temperature (**LLT**) = _____ °C

Suction Line Temperature (**SLT**) = _____ °C

NOTES

- Accurate pressure and temperature measuring tools should be used to achieve satisfactory results.
- The sensors of thermocouple must be in good contact with the area being measured and must be insulated in order to obtain correct reading.

Checking for Subcooling

1. From the Pressure / Temperature Chart, record the corresponding Saturated Condensing Temperature (**SCT**) at the given discharge pressure.
2. Calculate the system subcooling using the formula below:

$$\text{Subcooling} = \text{SCT} - \text{LLT}$$

3. If subcooling is within the range (see charging table), there is no need to add/remove refrigerant.
 - If subcooling is lower than minimum, the system is undercharged, it is necessary to add refrigerant.
 - If subcooling is higher than maximum, the system is overcharged, it is necessary to remove refrigerant.

Allow the systems to stabilise (15 - 30 mins) and repeat the steps 1-3 until subcooling falls within the range specified in the Subcooling/Superheat Table below.

Checking for Superheat

Maintaining the correct superheat is important for ensuring the evaporator is achieving maximum capacity and avoiding excessive liquid refrigerant returning to the compressor.

1. From the Pressure/Temperature Chart, record the corresponding Saturated Suction Temperature (**SST**) at the given suction pressure.
2. Calculate the system super heat using the formula below:

$$\text{Superheat} = \text{SLT} - \text{SST}$$

3. If superheat is within the range (see charging table), there is no need to add/remove refrigerant.
 - If superheat is lower than minimum, it means that liquid refrigerant may be returning to compressor. It is necessary to remove refrigerant or check EEV settings.
 - If superheat is higher than maximum, it means that refrigeration capability of evaporator is not fully maximised. It is necessary to add refrigerant charge or check EEV settings.

Allow the systems to stabilise (15 - 30 mins) and repeat the steps 1-3 until superheat falls within the range specified in the table below.

| Subcooling/Superheat Table | | | |
|----------------------------|-----------|------------|-----------|
| Cooling | | Heating | |
| Subcooling | Superheat | Subcooling | Superheat |
| 4 - 8 | 4 - 8 | 10 - 14 | 2.5 - 6 |

NOTES

The above subcooling and superheat recommendations are based on the following rated conditions:

- Cooling: 35°C DB outdoor, air entering indoor at 27°C DB / 19°C WB.
- Heating: 7°C DB / 6°C WB outdoor, air entering indoor at 20°C DB Nominal indoor airflow.

CHARGING TABLE

| Temp °C | Pressure KPa | Temp °C | Pressure KPa | Temp °C | Pressure KPa | Temp °C | Pressure KPa |
|------------|-----------------|------------|-----------------|------------|-----------------|------------|-----------------|
| -50 | 9 | -19 | 320 | 11 | 1040 | 41 | 2439 |
| -49 | 15 | -18 | 336 | 12 | 1073 | 42 | 2500 |
| -48 | 20 | -17 | 353 | 13 | 1108 | 43 | 2564 |
| -47 | 27 | -16 | 369 | 14 | 1143 | 44 | 2628 |
| -46 | 33 | -15 | 387 | 15 | 1180 | 45 | 2694 |
| -45 | 40 | -14 | 405 | 16 | 1217 | 46 | 2760 |
| -44 | 46 | -13 | 424 | 17 | 1255 | 47 | 2829 |
| -43 | 54 | -12 | 442 | 18 | 1293 | 48 | 2898 |
| -42 | 61 | -11 | 462 | 19 | 1333 | 49 | 2969 |
| -41 | 69 | -10 | 481 | 20 | 1373 | 50 | 3040 |
| -40 | 76 | -9 | 502 | 21 | 1415 | 51 | 3114 |
| -39 | 85 | -8 | 523 | 22 | 1457 | 52 | 3187 |
| -38 | 93 | -7 | 545 | 23 | 1501 | 53 | 3264 |
| -37 | 102 | -6 | 567 | 24 | 1544 | 54 | 3340 |
| -36 | 111 | -5 | 590 | 25 | 1589 | 55 | 3419 |
| -35 | 121 | -4 | 613 | 26 | 1634 | 56 | 3498 |
| -34 | 130 | -3 | 637 | 27 | 1681 | 57 | 3580 |
| -33 | 140 | -2 | 661 | 28 | 1728 | 58 | 3662 |
| -32 | 150 | -1 | 687 | 29 | 1777 | 59 | 3747 |
| -31 | 161 | 0 | 712 | 30 | 1826 | 60 | 3832 |
| -30 | 172 | 1 | 739 | 31 | 1877 | 61 | 3920 |
| -29 | 184 | 2 | 765 | 32 | 1928 | 62 | 4008 |
| -28 | 195 | 3 | 793 | 33 | 1981 | 63 | 4099 |
| -27 | 208 | 4 | 821 | 34 | 2034 | 64 | 4190 |
| -26 | 220 | 5 | 851 | 35 | 2089 | 65 | 4284 |
| -25 | 234 | 6 | 880 | 36 | 2144 | 66 | 4378 |
| -24 | 247 | 7 | 911 | 37 | 2201 | 67 | 4476 |
| -23 | 261 | 8 | 941 | 38 | 2258 | 68 | 4573 |
| -22 | 275 | 9 | 974 | 39 | 2318 | 69 | 4675 |
| -21 | 290 | 10 | 1006 | 40 | 2377 | 70 | 4776 |
| -20 | 304 | | | | | | |

Maintenance

Maintenance Procedures

This section describes the procedures that must be performed as a part of normal maintenance program. Regular servicing of equipment by licensed technician is highly recommended. Regular servicing of your unit helps in maintaining its optimum performance and reliability. **The checklist and service periods provided on this manual are guides only, as some sites may require more frequent servicing.** Always disconnect electrical power to the unit before performing these procedures unless otherwise required. It is always a safe practice to observe all safety warnings and cautions when conducting maintenance tasks.



DANGER

Live Electrical Connections!

It may be necessary to work with live electrical components on certain maintenance tasks. Only licensed electricians and qualified technicians are allowed to perform these tasks.

Beware of Rotating Fan Blades!

Always make sure that all power supplied to the fans are turned Off and isolated.

Observe WH&S safety procedures, do not wear loose clothing and any jewellery when working near the fans.

Wear PPE whenever performing any maintenance procedures.

Observe all necessary procedures when working on a confined space.



WARNING

Hazardous Voltage!

Always make sure that all power supply, including remote controls, are disconnected before performing maintenance.

Observe proper LOCK-OUT/TAG-OUT procedures to ensure that power cannot be inadvertently energised. Failure to disconnect power before maintenance procedures can result in serious injury and/or death.

EC Motors are fitted with high power capacitors and can have dangerous residual voltages at motor terminals after power has been isolated. Wait at least 5 minutes after power isolation and test for any residual voltage before beginning service work.

Annual Maintenance Checklists

- Perform general maintenance inspections.
- Perform scheduled start-up checks.
- Leak test refrigerant circuits.
- Inspect contacts of all contactors and relays. Replace all worn contacts as required.
- Inspect, clean and tighten all electrical connections.
- Check fans for balanced operation. Make sure that there are no loose screws / bolts, no fan blades interference and no damage to the fans and guards.
- Inspect the air filters, clean or replace as required.
- Clean and repaint any corroded panel section.
- Ensure no blockage of airflow through variable speed drive.

Cleaning the Condenser Coils

Clean the coils at least once a year or more frequently if unit is located in a dusty and dirty environment, in order to maintain your system's proper operating performance. High discharge pressures are good indication that the coils need cleaning. When using detergent or solvents to clean the coils, follow the manufacturer's instructions to avoid potential damage to the coils and to the unit.

To clean the refrigerant coils, use a soft brush and water spray, such as garden hose or pressure washer with low pressure nozzle.

 **WARNING****Do Not Use High Alkaline Detergent!**

When using detergent for coil cleaning, ensure that the alkaline level is no higher than 8.5, which can cause corrosion damage to the coils.

 **DANGER****No Water into the Electrical Compartments!**

Ensure consideration is given to the possibility of water entering the electrical compartments during cleaning of the condenser coil.

Coil Cleaning Procedures

- Disconnect power to the unit.
- Remove the louvered panels from the unit to gain access to the air inlet side of the coils.
- Use a soft brush to remove loose dirt and debris from both sides of the coils.
- Straighten bent coil fins with fin comb.
- Prepare the detergent solutions according to the manufacturer's instructions.
- Spray solution at a 90° angle to the coils, keeping a minimum nozzle spray angle of 15°, with at least a 1800mm distance from the coils and 600 psi pressure.
- Spray leaving air side of the coils first then the air inlet side. Allow the solution to stand on the coils for five minutes.
- Rinse both sides of the coils with cool clean water.
- Inspect the coils, if they are still dirty, repeat the cleaning procedure.
- Clean and wipe dry the outer and inner sides of the unit, the refrigerating parts and other components.
- Ensure that the condensate drain lines are not blocked.
- Reinstall all unit panels, covers and guards.
- Restore electrical power to the unit.

Maintenance Frequency Checklist

Regular servicing of equipment by a qualified technician is recommended every 12 months for residential applications and every quarter for commercial applications. Regular servicing of your unit helps in maintaining its optimum performance and reliability. **The following checklist and service periods are provided as a guide only, as some sites may require more frequent servicing.**

| ELECTRICAL | | | | | | | | | | | |
|------------------------|----------------|-------|-------|------|-------|-------------------------|-----------------|-------|-------|--|--|
| Parts | Service Period | | | | | Detail of Service Check | Service Methods | | | | |
| | 1 Mth | 3 Mth | 6 Mth | 1 Yr | 2 Yrs | | | 3 Yrs | 4 Yrs | 5 Yrs | |
| Printed Circuit Boards | | | | ✓ | | | | | | Visual Inspection | Tighten Terminals as necessary on printed circuit boards |
| Electrical Connections | | | | ✓ | | | | | | Check all electrical terminals, mains, communications, etc | Re-tighten if loose. |

| INDOOR UNIT | | | | | | | | | | | |
|------------------------------|----------------|-------|-------|--------|-------|-------------------------|-----------------|-------|-------|--|--|
| Parts | Service Period | | | | | Detail of Service Check | Service Methods | | | | |
| | 1 Mth | 3 Mth | 6 Mth | 1 Yr | 2 Yrs | | | 3 Yrs | 4 Yrs | 5 Yrs | |
| Casing / Panels and Frames | | | | ✓ | | | | | | Visual check for damage, rust and dust accumulation. | For highly corrosive environment, wash panels quarterly with water and neutral detergent solution. Wax panels. Repair / re-paint where required. |
| Insulation | | | | ✓ | | | | | | Visual check for insulation conditions. | Repair / replace insulation material. |
| Fan | | | | ✓ | | | | | | Visual check for run out of balance and dust attached | Clean off dust as necessary to negate possibility of fan running out of balance |
| Motor | | | | ✓ Ω | | | | | | Visual check on wiring. Insulation resistance check to be carried out annually | Measure insulation resistance. Reading should be more than 1MΩ. |
| Heat Exchanger | | | | ✓ | | | | | | Check for clogging by dust. Check for leaks / damage. | Clean air inlet side as necessary. Straighten any bent fins using fins comb. |
| Drain Pan/ Condensation line | | | | ✓ | | | | | | Check for obstructions and free flow of water | Clean to eliminate obstructions/ sludge and check condition of pan. Pour water to ensure flow |
| Filter* | | ✓ | | | | | | | | Check for clogging by dust. | Clean Filter |
| Temperature Readings | | | | ✓ | | | | | | Measure air on and air off | Place temperature probe in return and supply air of unit. |
| Damper Motors (if fitted) | | | | ✓ | | | | | | Visual inspection of motors open/closing. Ensure no obstructions | Drive motors opened and closed. Ensure correct operation |
| Duct Works | | | | ✓ | | | | | | Inspect duct works for air gaps. | Re-tape any loose ducts. |

* Service period for filter cleaning may vary depending on operating time and surrounding environment.

| OUTDOOR UNIT | | | | | | | | | | Detail of Service Check | Service Methods |
|--------------------------------------|----------------|----------|----------|---------|----------|----------|----------|----------|--|--|--|
| Parts | Service Period | | | | | | | | | | |
| | 1 Mth | 3 Mth | 6 Mth | 1 Yr | 2 Yrs | 3 Yrs | 4 Yrs | 5 Yrs | | | |
| Casing / Panels and Frames | | | | ✓ | | | | | | Visual check for damage, rust and dust accumulation. | For highly corrosive environment, wash panels quarterly with water and neutral detergent solution. Wax panels. Repair / re-paint where required. |
| Insulation | | | | ✓ | | | | | | Visual check for insulation conditions. | Repair / replace insulation material. |
| Fan | | | | ✓ | | | | | | Visual check for run out of balance and dust attached | Clean off dust as necessary to negate possibility of fan running out of balance |
| Motor | | | | ✓ Ω | | | | | | Visual check on wiring. Insulation resistance check to be carried out annually | Measure insulation resistance. Should be more than 1MΩ |
| Heat Exchanger | | | | ✓ | | | | | | Check for clogging by dust. Check for leaks / damage. | Clean air inlet side as necessary. Straighten any bent fins using fins comb. |
| Condensate Drain Line (if available) | | | | ✓ | | | | | | Check for obstructions and free flow of water | Clean to eliminate obstructions/ sludge and check condition of drain line. Pour water to ensure free flow. |
| Compressor | | | | ✓ Ω | | | | | | Check for high / low pressure. Measure insulation resistance. Check compressor for abnormal noise/vibrations | Measure insulation resistance. Should be more than 1MΩ. |
| Refrigeration Operational Readings | | | | ✓ | | | | | | Make note of operational reading in test cool/heat | Check operating pressures, record superheat and subcooling values |
| Safety Devices | | | | ✓ | | | | | | Check calibration of safety devices such as HP and LP controls, sensors, etc | Check resistance of sensors, pressure cut in / cut out of pressure controls |
| Faults | | | | ✓ | | | | | | Check for any previous fault history on unit. | Investigate any causes for previous faults, reset fault history. |

Version History

| DOCUMENT VERSION | BOM VERSION | UPDATE HISTORY |
|------------------|-------------|----------------|
| Ver 1 | -01 | Released |



©Copyright 2025 Actron Engineering Pty Limited ABN 34 002767240. ®Registered Trade Marks of Actron Engineering Pty Limited. ActronAir is constantly seeking ways to improve the design of its products. Therefore, specifications are subject to change without notice.