



# Factor Horticulture LED Lighting System



## BEFORE YOU BEGIN / AVANT DE COMMENCER

Read these instructions completely and carefully. Lisez attentivement ces instructions dans leur intégralité. For Commercial or Industrial use only.

**RISK OF SAFETY AND PRODUCT DAMAGE. DO NOT MAKE OR BREAK ELECTRICAL CONNECTION WHILE POWER IS APPLIED.**

### ⚠ WARNING / AVERTISSEMENT / ADVERTENCIA

#### RISK OF ELECTRIC SHOCK

Turn power off before installation, inspection, cleaning or removal.

#### RISQUE DE CHOC ELECTRIQUE

Coupez l'alimentation avant l'installation, l'inspection, le nettoyage ou le retrait.

#### RIESGO DE SHOCK ELÉCTRICO

Apague la energía antes de la instalación, inspección, limpieza o remoción.

### ⚠ WARNING / AVERTISSEMENT

#### RISK OF ELECTRIC SHOCK

- Follow appropriate lock out/tag out safety procedure.
- Properly ground electrical enclosure.
- Follow all National Electric Codes (NEC) and local codes.
- This product must be installed in accordance with the applicable installation code by a person familiar with the construction and operation of the product and the hazards involved.**
- The installation and associated structures are subject to approval by the authority having jurisdiction.
- Use only with components identified in this document.
- Suitable for dry, damp, and wet locations; Do not immerse any component.
- Wear suitable Personal Protective Equipment (PPE) during installation/maintenance. Highly recommend safety glasses, helmet and leather glove for luminaire mounting.

#### RISK OF FIRE

- Minimum 3 inch distance from lightbar & driver to any combustible material.
- Minimum 3 inch clearance between, lightbar & driver, lightbar & lightbar, driver & driver.
- The lightbar shall be installed lens down with a minimum 6 inch distance to anything below.
- All cables including connectors shall not be concealed or extended through a wall, floor, ceiling, or other parts of the building structure; located above a suspended ceiling or dropped ceiling; permanently affixed to the building structure.
- Cables shall be routed so that they are not subject to strain and are protected from physical damage; visible over their entire length; and used within their rated ampacity as determined for the maximum temperature of the installed environment specified in the instructions.
- For safe operation, and to maximize the longevity of the luminaire; ensure that the lightbar and driver are clean and free of dirt, dust, oil, or any other debris. Do not apply any kind of film on the lens or otherwise cover the driver or light engine in any way.

#### RISQUE DE CHOC ELECTRIQUE

- Suivez la procédure de sécurité appropriée de verrouillage/étiquetage.
- Reliez correctement le boîtier électrique à la mise à la terre.
- Suivre tous les codes électriques locaux applicables.
- Ce produit doit être installé selon le code d'installation pertinent, par une personne qui connaît bien le produit et son fonctionnement ainsi que les risques inhérents.**
- L'installation et les structures associées sont soumises à l'approbation des autorités compétentes.
- Utilisez uniquement avec les composants identifiés dans ce document.
- Convient aux endroits secs, humides et mouillés. Ne doit pas être immergé.
- Portez les équipements de protection individuelle appropriés pendant l'installation et la maintenance. L'utilisation de lunettes de sécurité, d'un casque et des gants de cuir pour le montage du luminaire est fortement recommandée.

#### RISQUE D'INCENDIE

- Distance minimale de 3 pouces entre l'équipement d'éclairage et toute matière combustible.
- Distance minimale de 3 pouces entre tout équipement d'éclairage, lightbar d'éclairage ou lightbar d'alimentation.
- Le luminaire doit être installé avec l'objectif pointé vers le bas avec une distance minimale de 6 pouces entre le luminaire et tout objet.
- Les câbles et connecteurs ne doivent pas être dissimulés à l'intérieur, ou passer à travers, d'un mur, d'un plancher, d'un plafond ou de toute autre partie de la structure du bâtiment; ne doivent pas être placés au-dessus d'un plafond suspendu; ne doivent pas faire partie intégrante de la structure du bâtiment.
- Les câbles doivent être installés de façon à être protégés contre l'étirement et tout autre bris physique; visibles sur toute leur longueur; utilisés dans la limite de leur courant admissible, déterminée pour les limites de température de l'environnement spécifiées dans le guide d'instruction.
- Pour une opération sécurisée et pour maximiser la longévité du luminaire; S'assurer que le lightbar d'éclairage et le lightbar d'alimentation sont propres et sans saleté, poussière, huile ou autres débris. Ne pas appliquer tout type de film sur les lentilles et ne pas couvrir le lightbar d'alimentation ou le lightbar d'éclairage de quelque manière.

Suitable for operation in an ambient temperature as follows: 32°F-86°F (0-30°C) for VAFS 2, 32°F-104°F (0-40°C) for VAFS 4, 5, or 6. A mechanical ventilation or cooling system is required to maintain the temperature as above when the lightbar is in operation.

Convient pour un fonctionnement à une température ambiante comme suit: 0-30°C (32°F-86°F) pour VAFS 2, 0-40°C (32°F-104°F) pour VAFS 4, 5, or 6. Un système de ventilation ou de refroidissement mécanique est nécessaire pour maintenir la température comme ci-dessus lorsque le lightbar d'éclairage est en fonctionnement.



## Components

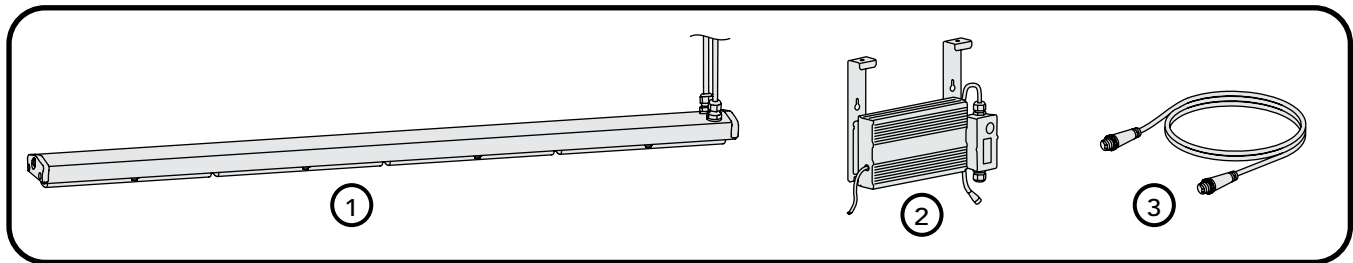

- ① Factor Series lightbars (See *Lightbar Specifications* table on page 2 for details)
- ② GEPS210-600\*-A\*\*NA Series LED Driver
- ③ *Optional:* Interconnection cable (VAFEX3FT, VAFEX)

## Lightbar Specifications ①

Product Code	Detailed Description	Weight	Series Load per Driver	System Watts per Lightbar
VAFS-HPKRW1*	VAFS 2, PKR	2.6 kg (5.7lbs)	2	319W
VAFS-HPKBW1*	VAFS 2, PKB	2.6 kg (5.7lbs)	2	313W
VAFS-HPKFW1	VAFS 2, PKF	2.6 kg (5.7lbs)	2	313W
VAFS-HBRIW1*	VAFS 2, BRI	2.6 kg (5.7lbs)	2	319W
VAFS-HBRVW1*	VAFS 2, BRV	2.6 kg (5.7lbs)	2	316W
VAFS-MPKRW1	VAFS 4, 5, or 6, PKR	2.6 kg (5.7lbs)	4, 5, or 6	104W
VAFS-MPKBW1	VAFS 4, 5, or 6, PKB	2.6 kg (5.7lbs)	4, 5, or 6	104W
VAFS-MPKFW1	VAFS 4, 5, or 6, PKF	2.6 kg (5.7lbs)	4, 5, or 6	106W
VAFS-MBRIW1	VAFS 4, 5, or 6, BRI	2.6 kg (5.7lbs)	4, 5, or 6	106W
VAFS-MBRVW1	VAFS 4, 5, or 6, BRV	2.6 kg (5.7lbs)	4, 5, or 6	106W
VAFS-EPKBW1	VAFS 4, 5, or 6, PKB	2.6 kg (5.7lbs)	5, 6, 7, or 8	82W

\* Risk Group 1 for photobiological per IEC 62471. All others in Exempt group.

## LED Driver Specifications ②

Description	Detailed Description	Weight	Driver Max Input Ratings	
			Voltage	Current
GEPS210-600D-ADGNA-D1XA1	Cord /w Leads	3.33 kg (7.3lbs)	120/208/240/277 VAC	6 / 3.5 / 3 / 2.6A
GEPS210-600D-ADGNA-D15A1	NEMA 5-15P	3.48 kg (7.33lbs)	120 VAC	6A
GEPS210-600D-ADGNA-D16A1	NEMA L6-15P	3.48 kg (7.33lbs)	240 VAC	3A
GEPS210-600D-ADGNA-D17A1	NEMA L7-15P	3.48 kg (7.33lbs)	277 VAC	2.6A
GEPS210-600G-AGJNA-D1XA1	Cord /w Leads	3.33 kg (7.3lbs)	277/347/480 VAC	2.5 / 2 / 1.5A
GEPS210-600G-AGJNA-D17A1	NEMA L7-15P	3.48 kg (7.33lbs)	277 VAC	2.5A

## Interconnection Cables Specifications ③

Ordering Nomenclature	Detailed Description	Weight
VAFEX3FT	Interconnection cable greenhouse 3 feet, UL	0.16kg (0.4 lbs)
VAFEX	Interconnection cable greenhouse 6 feet, UL	0.32kg (0.7 lbs)

## Mounting Accessories

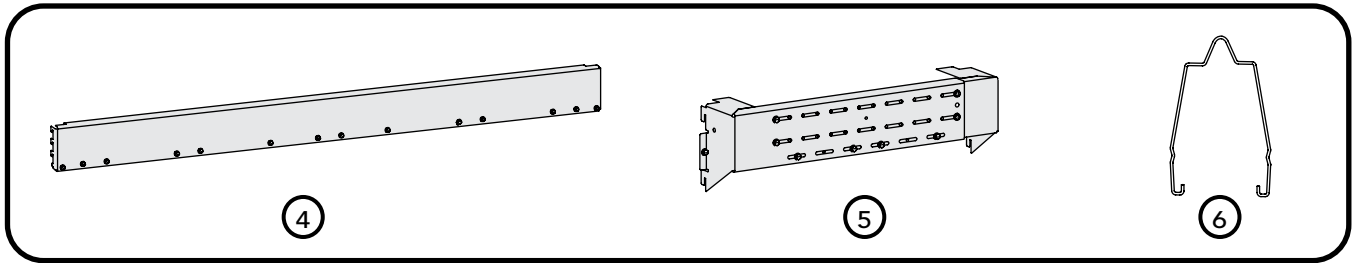

- ④ Rolling Rack Mount, 48" (VAFMTRR48)
- ⑤ Rolling Rack Mount, 24" (VAFMTRR24)
- ⑥ Suspended Wire Form Support (VAFMTSB)

## Mounting Accessories

Ordering Nomenclature	Detailed Description	Weight
④ VAFSMTRR48	Factor rolling rack mount, 48 inch pitch	3.69 kg (8.1 lbs)
⑤ VAFSMTRR24	Factor rolling rack mount, 24 inch pitch	1.756 kg (3.86 lbs)
⑥ VAFSMTSB	Factor suspended mount wireform support	0.012 kg (0.026lbs)
⑦ VAFMTBLE	Factor light engine mount	3.82 kg (8.4 lbs)
⑧ VAFAC12	Driver universal 1' remote mount kit	0.2kg (0.4 lbs)
⑨ RK8VAF SC	Shorting cap	0.05kg (0.11lb)

## Mounting Distance

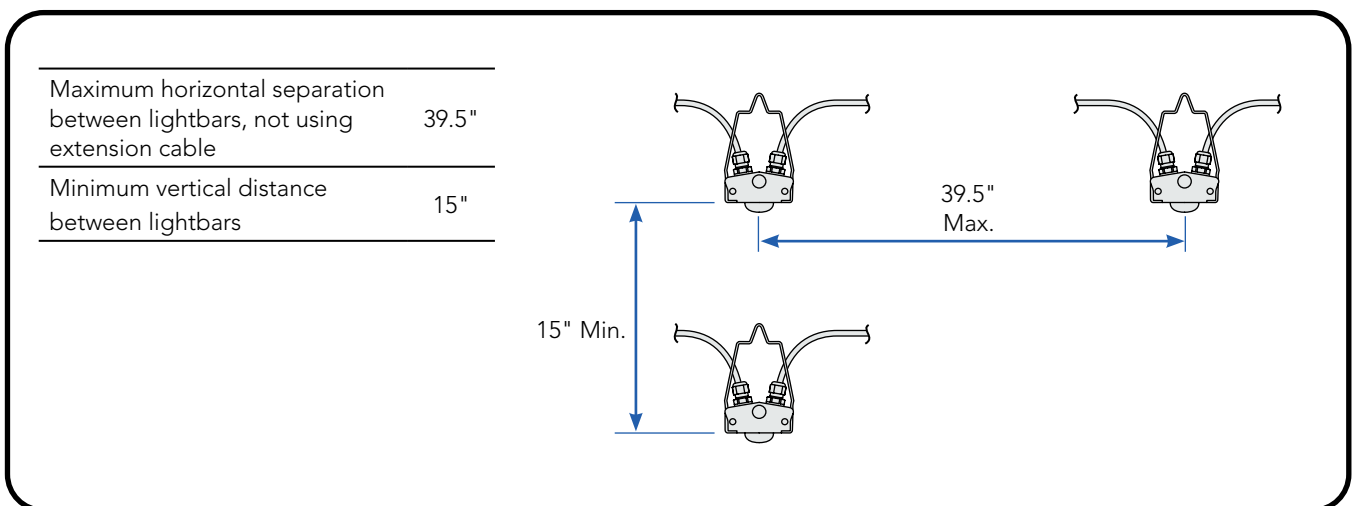

## Factor Series Rolling Rack Mount

### VAFS 2 Rolling Rack Mount, 48"

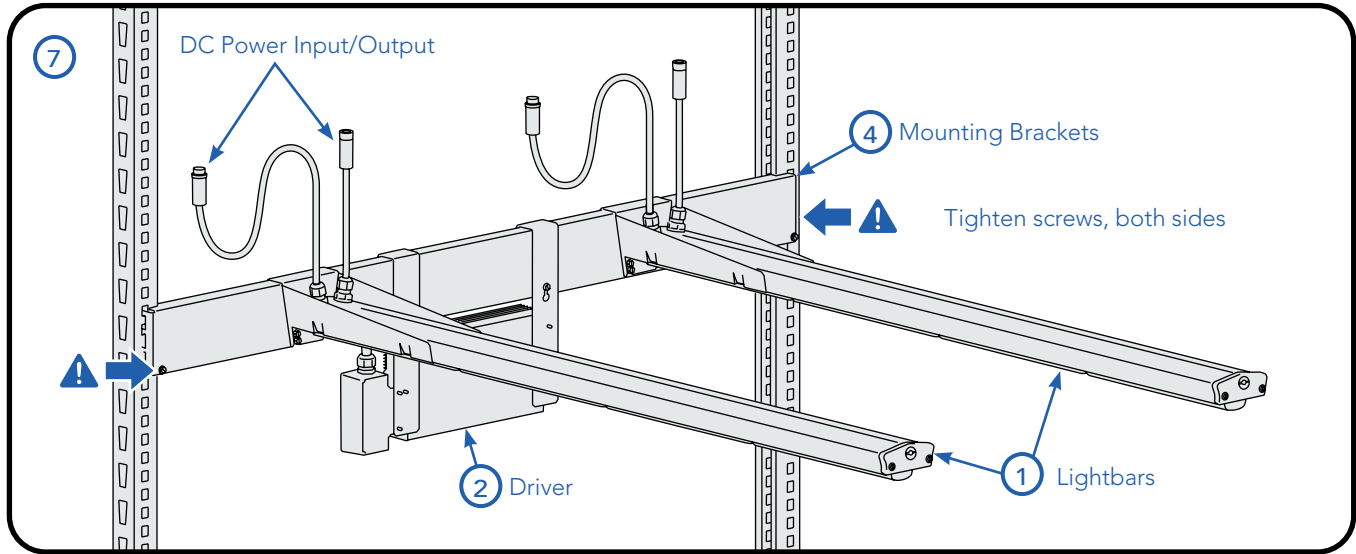

⚠ After the horizontal bracket is attached to the strut, secure the bracket to the strut by tightening the two screws located at each end of the bracket.

### VAFS 4, 5, or 6 Rolling Rack Mount, 24"

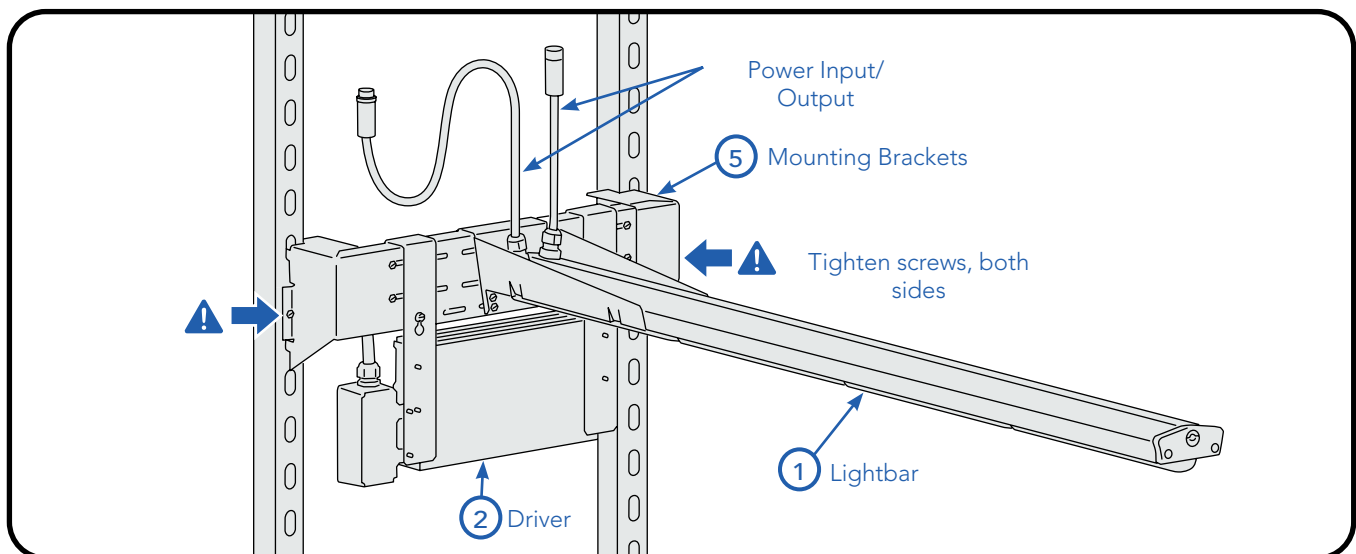

⚠ After the horizontal bracket is attached to the strut, secure the bracket to the struts by tightening the two screws, located each end of the bracket.

### Rolling Rack Installation Steps

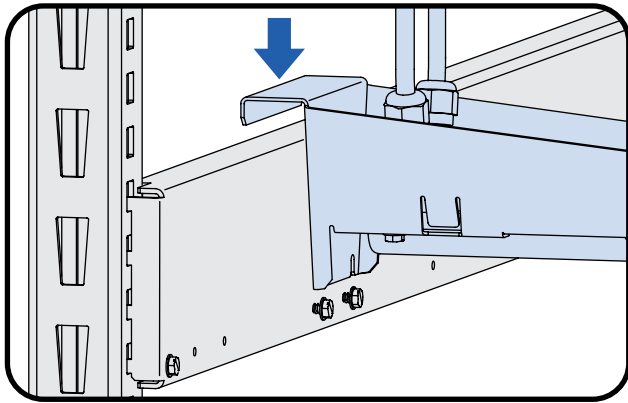

1 Place lightbar on VAFMTRR48 as shown, push down with screwdriver to secure on bracket

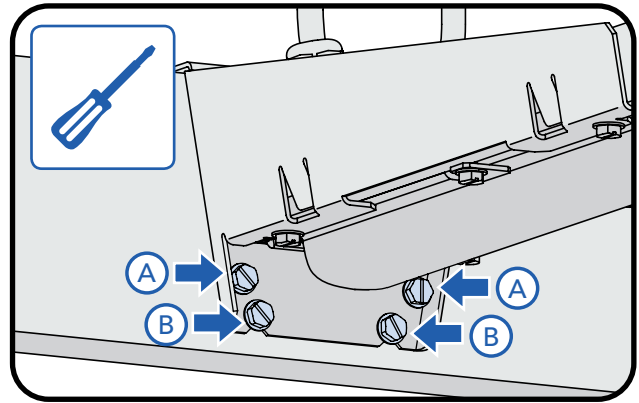

2 **A)** Adjust screws to level the lightbar with screwdriver. **B)** After lightbar is leveled, tighten the 2 screws at the bottom.

### Suspended Mount Installation Steps

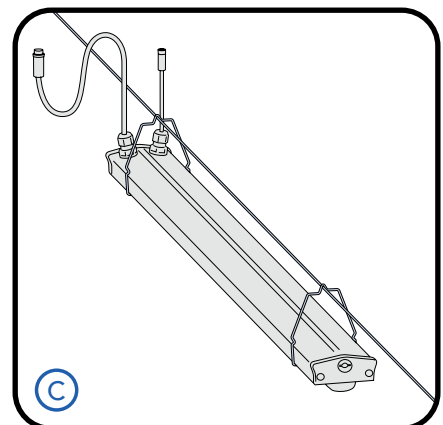
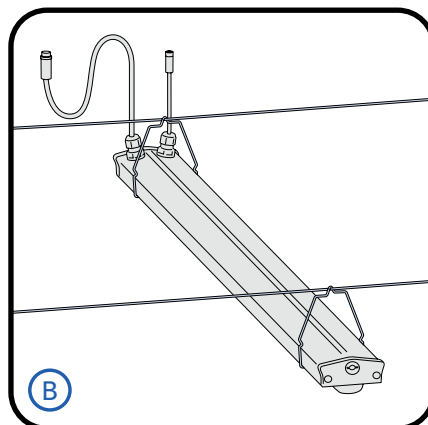
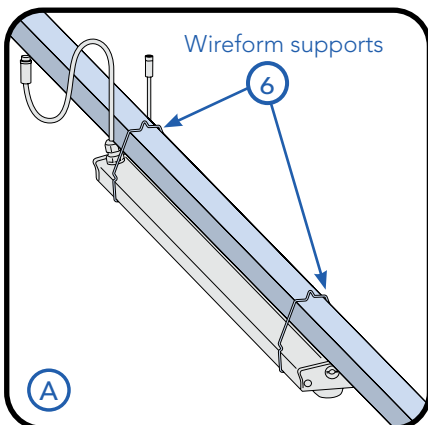

Using two wireform supports (VAFMTSB), the Factor Series lightbar can be suspended on a support structure (A) or on cables as shown above (B and C).

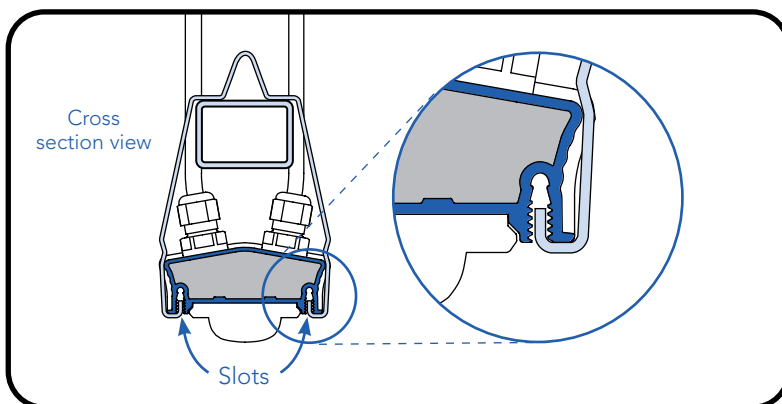

Attach wireform supports by pushing up into the slots on the underside of the lightbar.

### LED Driver Bracket Mount

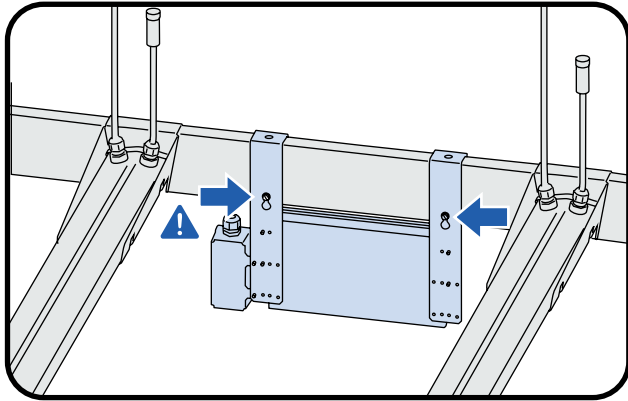

VAFS 2 LED Driver Mounting Option A Installation

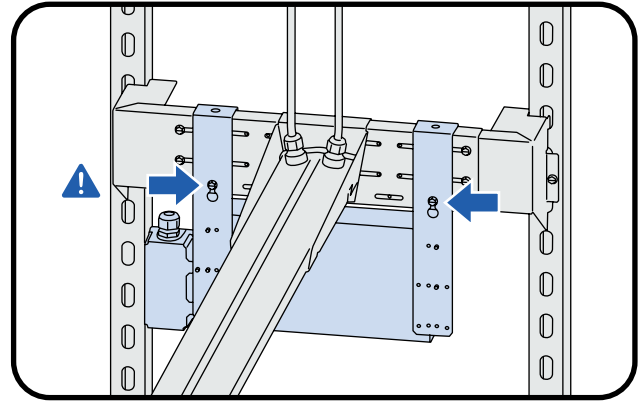

VAFS 4, 5, or 6 LED Driver Mounting Option A Installation

**⚠** After placing driver on mounting bracket, secure driver by tightening the screws shown.

### LED Driver Suspended Mount

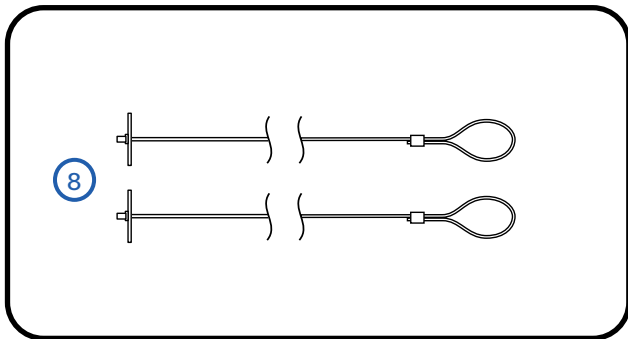

**1** **Components required:** VAFAC12 Driver universal 1' remote mount kit, 2 required.

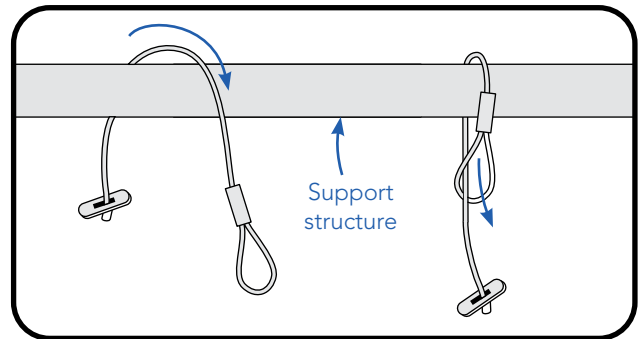

**2** Wrap the two toggle cables around the support structure. Thread the toggle through the loop in each toggle cable.

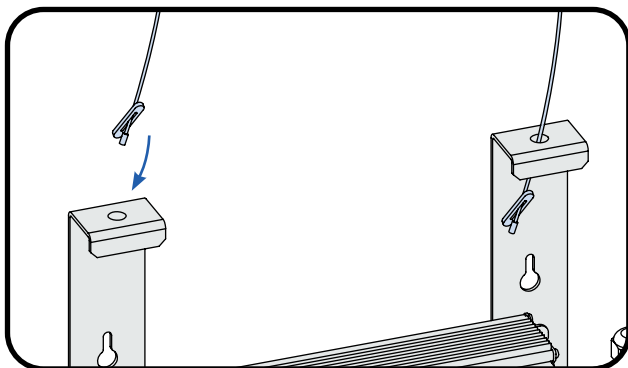

**3** Insert each toggle into the hole in the top of each driver bracket.

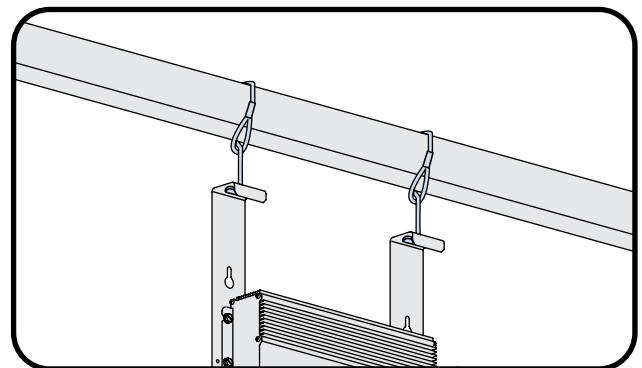

**4** Hang the driver from the support structure.

## Shorting Cap Installation



**RISK OF SAFETY AND PRODUCT DAMAGE. DO NOT MAKE OR BREAK ELECTRICAL CONNECTION WHILE POWER IS APPLIED.**

Connect the output of the driver to the first light bar using the 30" interconnection cable. The output of first light bar (6" cable) must be connected to the 30" cable of the 2nd lightbar, and so on.

- For VAFS 2, only 2 lightbars should be connected as shown.
- For VAFS 4, 5, or 6, a minimum of 4, and a maximum of 6 light bars can be connected. Connecting less than 4 VAFS light bars may damage the product.
- Connect the shorting cap to the last 6" lightbar cable, as shown, or else the array will not light. The shorting cap must be secured such that it does not touch the light bar.

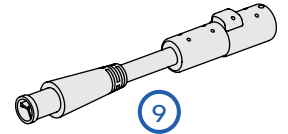

Shorting Cap

### VAFS 2 Electrical Connection: 2 Lightbars only

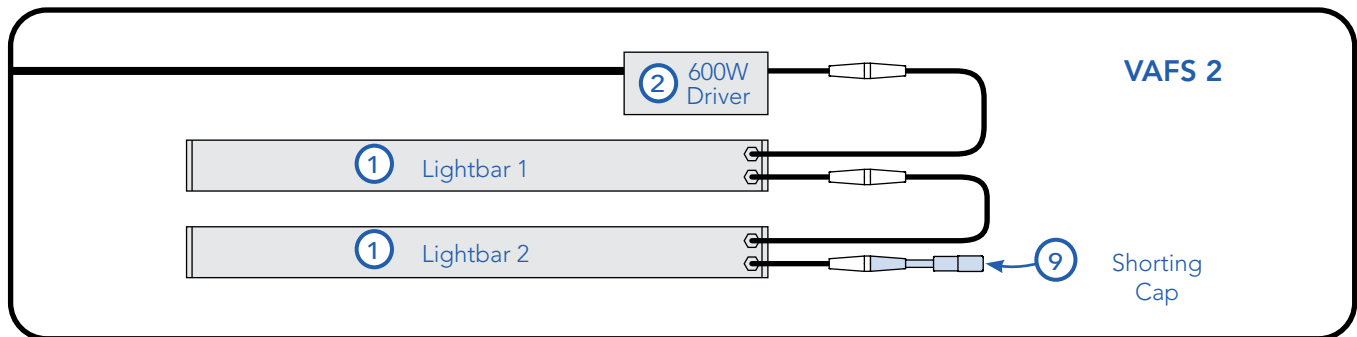

### VAFS 4, 5, or 6 Electrical connection: 4, 5, or 6 Lightbars only

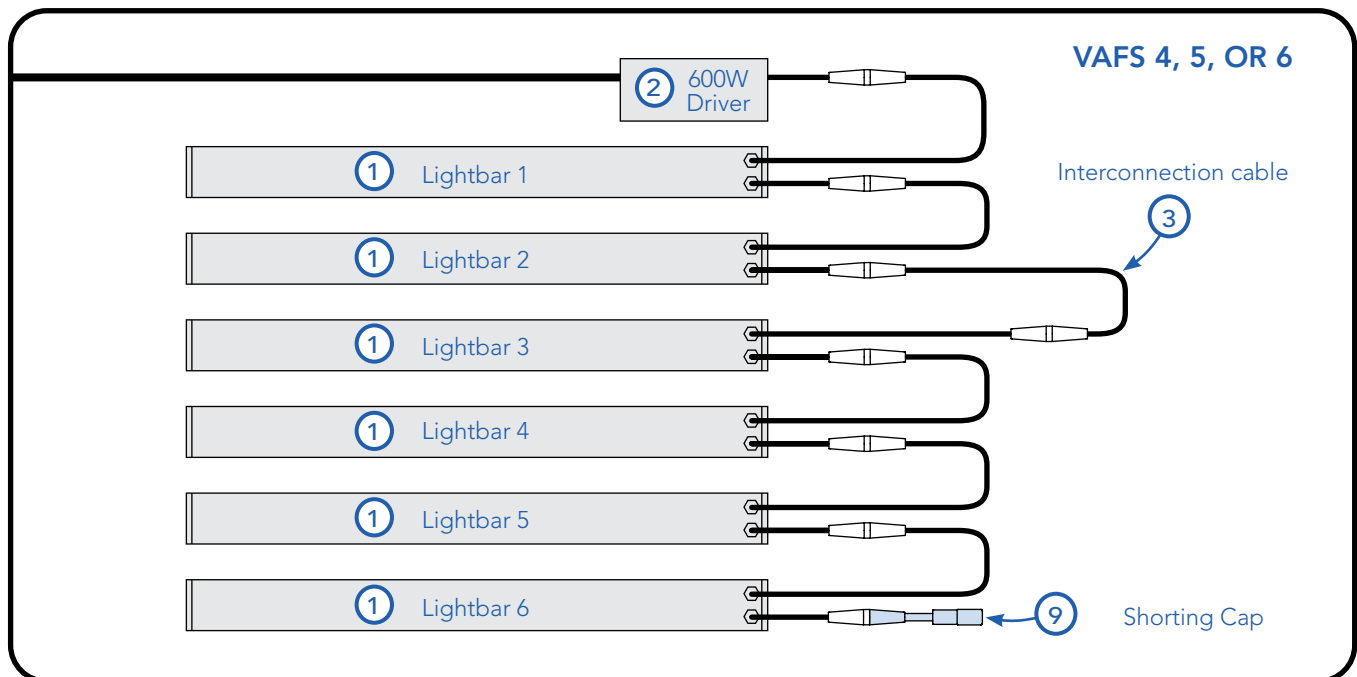

**!** For all configurations greater than 5 bars, only use 3ft or 6ft extension cable (VAFEX3FT or VAFEX interconnection cables) in conjunction with LED Drivers without NEMA plugs (GEPSC210-600D-ADGNA-D1XA1 and GEPSC210-600G-AGJNA-D1XA1).

## Driver Output and Lightbar Electrical Connections

### ⚠ WARNING / AVERTISSEMENT

RISK OF ELECTRIC SHOCK OR PRODUCT DAMAGE  
Turn power OFF before inspection, installation or removal.

RISQUE DE CHOC ÉLECTRIQUE OU DE DOMMAGE AU PRODUIT  
Coupez l'alimentation avant l'inspection, l'installation ou la désinstallation.

**DO NOT MAKE OR BREAK ELECTRICAL CONNECTION WHILE POWER IS APPLIED.**

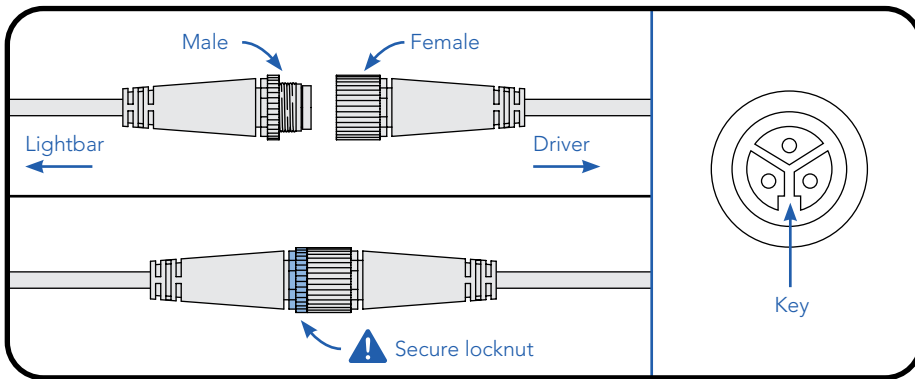

① Mate male connector from lightbar with female connector from DC output of driver. Ensure matching up the key guides from Male to Female connector.

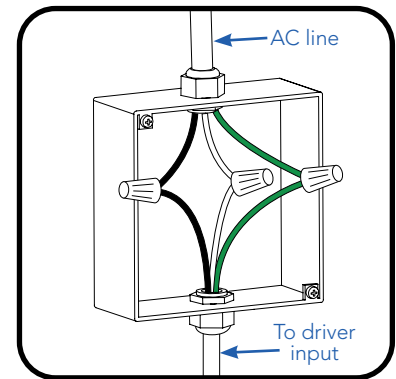

② Connect the green wire to the incoming ground conductor. Connect the black wire to Line 1 and white wires to Neutral or Line 2 of the incoming AC line.

## Connection Schematic

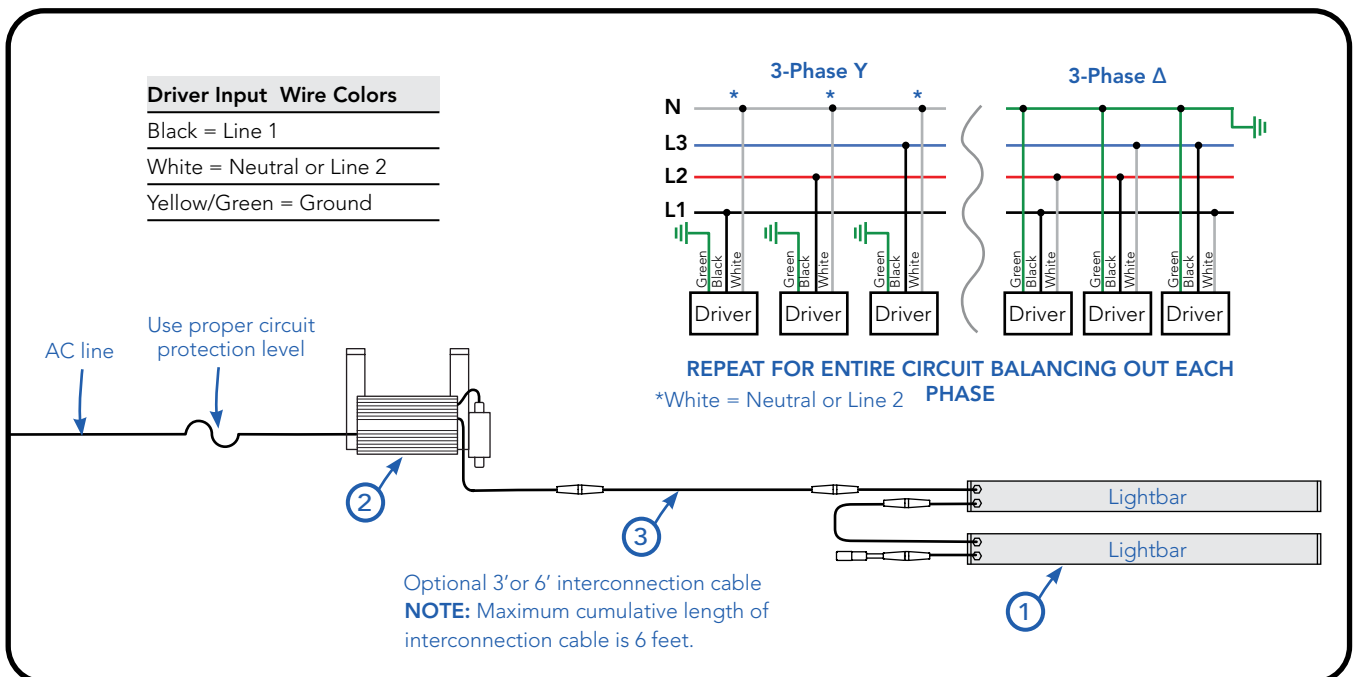

## Wired Dimming Connections (Optional)

### ⚠ WARNING / AVERTISSEMENT

#### RISK OF ELECTRIC SHOCK OR PRODUCT DAMAGE

- Turn power off before installation, inspection, cleaning or removal. Follow appropriate lock out/tag out safety procedure.
- This product must be installed in accordance with the applicable installation code by a person familiar with the construction and operation of the product and the hazards involved.

#### RISQUE DE CHOC ÉLECTRIQUE OU DE DOMMAGE AU PRODUIT

- Coupez l'alimentation avant l'inspection, l'installation ou la désinstallation. Suivez la procédure de sécurité appropriée de verrouillage/étiquetage.
- Ce produit doit être installé selon le code d'installation pertinent, par une personne qui connaît bien le produit et son fonctionnement ainsi que les risques inhérents.

**NOTE:** Arize Factor dimming allows user to adjust the light output from 0%/10-100%. When set to 0%, the system will enter standby mode, consuming 0.5-1.5W and LEDs may remain very faintly lit. If 0 light is preferred, switch off the unit via the mains (AC line).

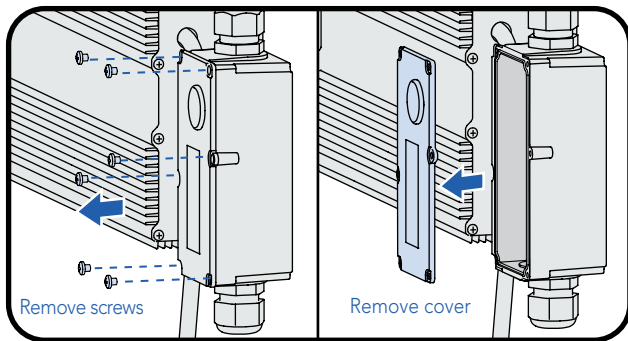

### 1 Junction Box Cover Removal

- Using a #1 Phillips screwdriver, unscrew the 6 screws on the junction box cover.
- Remove the junction box cover from the junction box enclosure.

**NOTE:** Be sure to hold on to the screws, junction box cover, and gasket for future use.

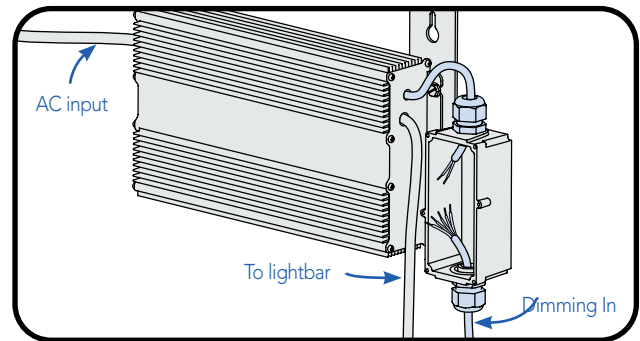

### 2 Wall Dimming Wire Insertion

- Remove the sealed gland in the bottom of the junction box enclosure, and install an appropriate Listed 1/2" NPT fitting rated for the environment into the open threaded open conduit connection.
- Bring the conductors for the building dimming network into this fitting.

**NOTE:** Customer is responsible for the 1/2" NPT- 14 thread per inch fitting.

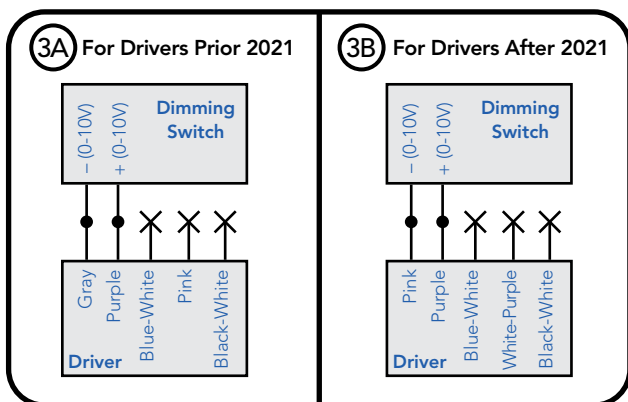

### 3 Wire Dimming Electrical Connections

- **3A - For Drivers Prior 2021**  
Connect the appropriate wiring to Dim + (0-10V) and Dim - (0-10V) from driver. Insulate the black-white, pink and blue-white wires. Follow dimming switch instructions for rest of connection.
- **3B - For Drivers After 2021**  
Connect the appropriate wiring to Dim + (0-10V) and Dim - (0-10V) from driver. Insulate the black-white, white-purple, and blue-white wires. Follow dimming switch instructions for rest of connection.

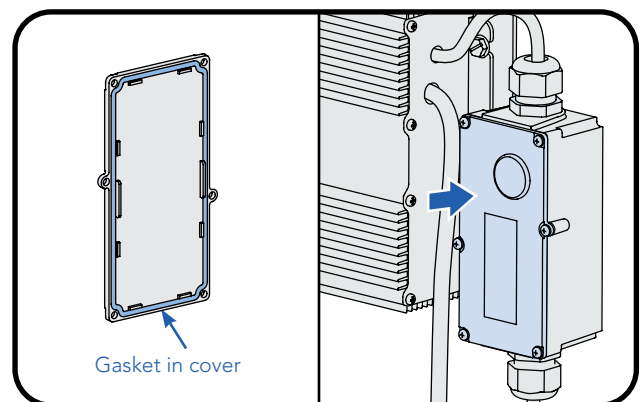

### 4 Junction Box Cover Replacement

- Ensure gasket is sitting in place on the inner edge of the junction box cover.
- Fasten all 6 screws to ensure water tight seal.

**NOTE:** Be careful not to strip out the junction box enclosure by over tightening the screws.

**⚠ RISK GROUP 1 - CAUTION / ATTENTION - RAYONNEMENT LUMINEUX GROUPE 1\***

Possibly hazardous optical radiation emitted from this product. Do not stare at operating lamp. May be harmful to the eyes.

Le rayonnement lumineux émis par ce produit est potentiellement dangereux. Ne pas regarder la lumière émise directement car elle pourrait occasionner des dommages aux yeux.

\* See Specification Table for Risk Group 1 models.

- These photobiological safety markings are based on testing of the light output characteristic of a single horticultural luminaire. Increased exposure risk to facility personnel may be present depending upon the number of horticultural luminaires and their placement and/or positioning within the plant growth facility.
- It is the responsibility of the plant growth facility to address these risks at the facility level and to ensure that people entering the plant growth areas while the lights are on, are aware of these risks and that appropriate safeguards are in place.
- Ces avertissements de sécurité photobiologiques sont basés sur des tests du rendement lumineux d'un seul luminaire horticole. Les employés risquent de souffrir d'une exposition accrue selon le nombre de luminaires horticoles et leur placement et / ou positionnement au sein de la serre / chambre de culture.
- Il relève de la responsabilité de l'opérateur de l'installation de gérer les risques au niveau de l'installation et de s'assurer que les personnes qui pénètrent dans les zones de croissance des plantes pendant que les lumières sont allumées soient conscientes des risques et que des mesures de protection appropriées soient en place.

## Save These Instructions

Use only in the manner intended by the manufacturer. If you have any questions, contact the manufacturer.

This device complies with part 15 of the FCC Rules. Operation is subject to the following two conditions: (1) This device may not cause harmful interference, and (2) this device must accept any interference received, including interference that may cause undesired operation.

NOTE: This equipment has been tested and found to comply with the limits for a Class A digital device, pursuant to part 15 of the FCC Rules. These limits are designed to provide reasonable protection against harmful interference when the equipment is operated in a commercial environment. This equipment generates, uses, and can radiate radio frequency energy and, if not installed and used in accordance with the instruction manual, may cause harmful interference to radio communications. Operation of this equipment in a residential area is likely to cause harmful interference in which case the user will be required to correct the interference at his own expense.

This Class [A] RFLD complies with the Canadian standard ICES-005. /CeDEFR de la classe [A] est conforme à la NMB-005 du Canada.



Electrical products must not be thrown out with domestic waste. They must be taken to a communal collecting point for environmentally friendly disposal in accordance with local regulations. Contact your local authorities or stockist for advice on recycling. The packaging material is recyclable. Dispose of the packaging in an environmentally friendly manner and make it available for the recyclable material collection-service.



For the latest install guides for your product go to:

<https://www.acuitybrands.com/verjure-horticulture-lighting>