



I8P HEX



User Instructions



©2021 ADJ Products, LLC all rights reserved. Information, specifications, diagrams, images, and instructions herein are subject to change without notice. ADJ Products, LLC logo and identifying product names and numbers herein are trademarks of ADJ Products, LLC. Copyright protection claimed includes all forms and matters of copyrightable materials and information now allowed by statutory or judicial law or hereinafter granted. Product names used in this document may be trademarks or registered trademarks of their respective companies and are hereby acknowledged. All non-ADJ Products, LLC brands and product names are trademarks or registered trademarks of their respective companies.

ADJ Products, LLC and all affiliated companies hereby disclaim any and all liabilities for property, equipment, building, and electrical damages, injuries to any persons, and direct or indirect economic loss associated with the use or reliance of any information contained within this document, and/or as a result of the improper, unsafe, insufficient and negligent assembly, installation, rigging, and operation of this product.

DOCUMENT VERSION



Due to additional product features and/or enhancements, an updated version of this document may be available online. Please check www.adj.com for the latest revision/update of this manual before beginning installation and/or programming.

Date	Document Version	Software Version >	DMX Channel Mode	Notes
10/18/21	1	1.10	6/7/8/12	Initial Release (previous manuals issued separately for 3-pin and 5-pin models; current model features both socket types)

Europe Energy Saving Notice
 Energy Saving Matters (EuP 2009/125/EC)
 Saving electric energy is a key to help protecting the environment. Please turn off all electrical products when they are not in use. To avoid power consumption in idle mode, disconnect all electrical equipment from power when not in use. Thank you!

INTRODUCTION

Unpacking: Thank you for purchasing the 18P Hex by ADJ Products, LLC. Every 18P Hex has been thoroughly tested and has been shipped in perfect operating condition. Carefully check the shipping carton for damage that may have occurred during shipping. If the carton appears to be damaged, carefully inspect your fixture for any damage and be sure all accessories necessary to operate the unit have arrived intact. In the event that damage has been found or parts are missing, please contact our toll free customer support number for further instructions. Do not return this unit to your dealer without first contacting customer support.

Introduction: The 18P Hex is a DMX intelligent, LED par fixture. This fixture can be used in a stand alone mode or connected in a primary/secondary configuration. This par has five operating modes: Sound Active mode, Program mode, RGBWA + UV dimmer mode, Static Color mode, and DMX control mode. The 18P has 4 DMX channel modes: 6, 7, 8, & 12.

Customer Support: ADJ Products, LLC provides a customer support line to provide set up help and to answer any question that may arise during your set up or initial operation. You may also visit us on the web at www.adj.com for any comments or suggestions. Service Hours are Monday through Friday 8:00 a.m. to 4:30 p.m. Pacific Standard Time.

Voice: (323) 582-2650
Fax: (323) 582-2941
E-mail: support@adj.com

Warning! To prevent or reduce the risk of electrical shock or fire, do not expose this unit to rain or moisture.

Caution! There are no user serviceable parts inside this unit. Do not attempt any repairs yourself, as doing so will void your manufacturer's warranty. In the unlikely event that your unit requires service, please contact ADJ Products, LLC.

PLEASE recycle the shipping carton when ever possible.

FEATURES

- Multi-Colors
- Five Operating Modes
- Electronic Dimming 0-100%
- 5 Dimmer Curves
- Built in Microphone
- DMX-512 protocol
- 3-Pin & 5-pin DMX Connection (previous manuals issued separately for 3-pin and 5-pin models; current model features both socket types)
- 4 DMX Modes: 6 Channel Mode, 7 Channel Mode, 8 Channel Mode, & 12 Channel Mode.
- Dotz Par RF compatible (Not Included)
- Power Cord Daisy Chain (see **Multi Unit Power Linking** section of this manual)

WARRANTY REGISTRATION

The 18P Hex carries a 2 year limited warranty. Please fill out the enclosed warranty card to validate your purchase. All returned service items, whether under warranty or not, must be freight pre-paid and accompanied by a return authorization (R.A.) number. The R.A. number must be clearly written on the outside of the return package. A brief description of the problem as well as the R.A. number must also be written down on a piece of paper included in the shipping carton. If the unit is under warranty, you must provide a copy of your proof of purchase invoice. You may obtain an R.A. number by contacting our customer support team on our customer support number. All packages returned to the service department not displaying an R.A. number on the outside of the package will be returned to the shipper.

INSTALLATION

The unit should be mounted using a mounting clamp (not provided), affixing it to the mounting bracket that is provided with the unit. Always ensure that the unit is firmly fixed to avoid vibration and slippage while operating. Always ensure that the structure to which you are attaching the unit is secure and is able to support at least 10 times the unit's weight. Also, always use a safety cable that can hold 12 times the weight of the unit when installing the fixture. The equipment must be installed by a professional, and it must be installed in a place where it is out of the reach of people's grasp.

SAFETY PRECAUTIONS

- To reduce the risk of electrical shock or fire, do not expose this unit to rain or moisture.
- Do not spill water or other liquids into or on to your unit.
- Do not attempt to operate this unit if the power cord has been frayed or broken.
- Do not attempt to remove or break off the ground prong from the electrical cord. This prong is used to reduce the risk of electrical shock and fire in case of an internal short.
- Disconnect from main power before making any type of connection.
- Do not remove the cover for any reason. There are no user serviceable parts inside.
- Never operate this unit with the cover removed.
- Never plug this unit in to a dimmer pack.
- Always be sure to mount this unit in an area that will allow proper ventilation. Allow about 6" (15cm) between this device and a wall.
- Do not attempt to operate this unit if it has been damaged in any way.
- This unit is intended for indoor use only. Use of this product outdoors voids all warranties.
- During long periods of non-use, disconnect the unit's main power.
- Always mount this unit in a safe and stable matter.
- Power supply cords should be routed so that they are not likely to be walked on or pinched by items placed upon or against them, paying particular attention to the point at which they exit from the unit.
- Cleaning - The fixture should be cleaned only as recommended by the manufacturer. See the **Cleaning** section of this manual for details.
- Heat - The appliance should be situated away from heat sources, such as radiators, heat registers, stoves, or other appliances (including amplifiers) that produce heat.
- The fixture should be serviced by qualified service personnel when:
 - A. The power supply cord or the plug has been damaged.
 - B. Objects have fallen onto, or liquid has been spilled into, the appliance.
 - C. The appliance has been exposed to rain or water.
 - D. The appliance does not appear to operate normally or exhibits a marked change in performance.

SAFETY PRECAUTIONS



**HIGH
INTENSITY
ULTRAVIOLET
LIGHT**



**AVOID DIRECT EYE & SKIN EXPOSURE.
WEAR PROPER EYE & SKIN PROTECTION.
SEE MANUAL FOR SAFETY INSTRUCTIONS.**

RISK GROUP 3 - RISK OF EXPOSURE TO ULTRAVIOLET (UV) RADIATION!

- **FIXTURE EMITS HIGH INTENSITY ULTRAVIOLET (UV) LIGHT AT A WAVELENGTH OF 390NM TO 410NM.**
- **WEAR PROPER EYE AND SKIN PROTECTION.**
- **AVOID PROLONGED PERIODS OF EXPOSURE.**
- **AVOID WEARING WHITE COLOR CLOTHING AND/OR USING (UV) PAINTS ON SKIN.**
- **AVOID DIRECT EYE AND/OR SKIN EXPOSURE AT DISTANCES SHORTER THAN 11 feet (3.3m).**
- **DO NOT OPERATE FIXTURE WITH DAMAGED OR MISSING EXTERNAL COVER PROTECTIVE LENS.**
- **DO NOT LOOK DIRECTLY INTO THE (UV) LIGHT AND/OR VIEW (UV) LIGHT DIRECTLY WITH OPTICAL INSTRUMENTS THAT MAY CONCENTRATE THE LIGHT/RADIATION OUTPUT.**
- **INDIVIDUALS SUFFERING FROM A RANGE OF EYE CONDITIONS, SUN-LIGHT EXPOSURE DISORDERS, OR INDIVIDUALS USING PHOTOLEN-SITIVE MEDICATION, MAY EXPERIENCE DISCOMFORT IF EXPOSED TO THE ULTRAVIOLET (UV) LIGHT EMITTED FROM THIS FIXTURE.**

SET UP

Power Supply: The ADJ 18P Hex contains an automatic voltage switch, which will automatically sense the voltage when it is plugged into the power source. With this switch there is no need to worry about the correct power voltage, and this unit can be plugged in anywhere.

DMX-512: DMX is short for Digital Multiplex. This is a universal protocol used as a form of communication between intelligent fixtures and controllers. A DMX controller sends DMX data instructions from the controller to the fixture. DMX data is sent as serial data that travels from fixture to fixture via the DATA “IN” and DATA “OUT” XLR terminals located on all DMX fixtures (most controllers only have a DATA “OUT” terminal).

DMX Linking: DMX is a language allowing all makes and models of different manufacturers to be linked together and operate from a single controller, as long as all fixtures and the controller are DMX compliant. To ensure proper DMX data transmission, try to use the shortest cable path possible when linking several DMX fixtures. The order in which fixtures are connected in a DMX line does not influence the DMX addressing. For example, a fixture assigned a DMX address of 1 may be placed anywhere in a DMX line: at the beginning, at the end, or anywhere in the middle. When a fixture is assigned a DMX address of 1, the DMX controller knows to send DATA assigned to address 1 to that unit, no matter where it is located in the DMX chain.

Data Cable (DMX Cable) Requirements (For DMX Operation): The 18P Hex can be controlled via DMX protocol. The 18P Hex has 4 DMX channel modes. Your unit and your DMX controller can accept either a standard 3-pin or 5-pin XLR connector for data input and data output. We recommend Accu-Cable DMX cables. If you are making your own cables, be sure to use standard 110-120 Ohm shielded cable (This cable may be purchased at almost all pro lighting stores). Your cables should be made with a male XLR connector at one end of the cable and a female XLR connector at the other. Also remember that DMX cable must be daisy chained and cannot be split.

Notice: If you opt to make your own cables, do not use the ground lug on the XLR connector. Do not connect the cable’s shield conductor to the ground lug or allow the shield conductor to come into contact with the XLR’s outer casing. Grounding the shield could cause a short circuit and erratic behavior.

Special Note: Line Termination. When longer runs of cable are used, you may need to use a terminator on the last unit to avoid erratic behavior. A terminator is a 110-120 ohm 1/4 watt resistor which is connected between pins 2 and 3 of a male XLR connector (DATA + and DATA -). This unit is inserted in the female XLR connector of the last unit in your daisy chain to terminate the line. Using a cable terminator (ADJ part number Z-DMX/T) will reduce the risk of erratic behavior.

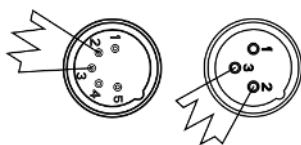

A DMX512 terminator reduces signal errors, avoiding most signal reflection interference. Connect PIN 2 (DMX-) and PIN 3 (DMX+) of the last fixture in series with a 120 Ohm, 1/4 W Resistor to terminate the DMX512.

SYSTEM MENU

MAIN MENU	OPTIONS / VALUES		DESCRIPTION	
Axxx	Axxx	A001 - A512	DMX Address Setting	
	CHxx	06 / 07 / 08 / 12	Select Channel Mode	
	dCxx	00 (Standard)		Select Dimming Curve Mode
		01 (Stage)		
		02 (TV)		
		03 (Architec)		
		04 (Theatre)		
	HOLd		Set fixture to HOLD state when DMX signal is lost	
bLC		Set fixture to BLACK OUT state when DMX signal is lost		
Soun		Set fixture to SOUND ACTIVE state when DMX signal is lost		
SEcd	SEcd		Set fixture to Secondary mode	
rxxx	rxxx	r000 - r255	Manual Dimming of RED LED	
	Gxxx	G000 - G255	Manual Dimming of GREEN LED	
	bxxx	b000 - b255	Manual Dimming of BLUE LED	
	wxxx	w000 - w255	Manual Dimming of WHITE LED	
	Axxx	A000 - A255	Manual Dimming of AMBER LED	
	Uxxx	U000 - U255	Manual Dimming of UV LED	
C-xx	C-xx	C-01 - C-64	Select Static Color	
P-xx	P-xx	P-01	Internal Program 01: 64 Color Change (Fade Speed)	
		P-02	Internal Program 02: 64 Color Change (No Fade Speed)	
		P-03	Internal Program 03: 64 Color Fade	
		P-04	Internal Program 04: 6 Color Change (No Fade Speed)	
		P-05	Internal Program 05: 6 Color Fade	
		P-06	Internal Program 06: 64 Color Fade + Sound Control (No Fade Speed / Speed Control)	
		P-07	Internal Program 07: 64 Color Change + Sound Control (No Fade Speed / Speed Control)	
	F-xx	F-00 - F-30	Select Fade Speed, fast to slow	
	S-xx	S-01 - S-30	Select Change Speed, fast to slow	
rFxx	rFof / rFon		Select RF mode, off or on	
Soxx	So00 - So30		Select Sound Control Sensitivity	

OPERATING INSTRUCTIONS

Control Panel Lock: The control panel will lock itself after 30 seconds of inactivity. To unlock the control panel, press and hold the MODE button for 3 seconds.

Operating Modes: The 18P Hex has five operating modes:

- DMX control mode - This function will allow you to control each individual fixtures traits with a standard DMX 512 controller.
- RGBWA + UV Mode - Choose one of the six colors to remain static or adjust the intensity of each color to create your own custom color.
- Sound Active Mode - The unit will react to sound, chasing through the built in programs. The sound sensitivity is adjustable.
- Program Mode - There are 7 built in programs to choose from. Color change and color fade speeds are adjustable.
- Static Color Mode - There are 64 colors to choose from.

DMX Mode: Operating through a DMX controller gives the user the freedom to create their own programs tailored to their own individual needs. The 18P Hex has 4 DMX modes: 6 Channel mode, 7 Channel mode, 8 Channel mode, and a 12 Channel mode. See the **DMX Traits** section of this manual for detailed information.

1. This function will allow you to control each individual fixture's traits with a standard DMX 512 controller.
2. To run your fixture in DMX mode press the MODE button until "Axxx" is displayed. "xxx" represents the currently selected address. Use the UP or DOWN buttons to select your desired DMX address, then press the ENTER button to select your DMX Channel mode.
3. Use the UP or DOWN buttons to scroll through the DMX Channel modes.
4. Connect your fixture to any standard DMX controller via the XLR connections.

RGBWA + UV Dimmer Mode: In this mode you can adjust the individual colors to make your desired color.

1. Plug the fixture in and press the MODE button until "rxxx" is displayed. You are in Red dimming mode. Press the UP and DOWN buttons to adjust the intensity. After you have finished adjusting the intensity, or if you would like to skip to the next color, press the ENTER button.
2. When "Gxxx" is displayed you are in Green dimming mode. Press the UP and DOWN buttons to adjust the intensity.
3. When "bxxx" is displayed you are in Blue dimming mode. Press the UP and DOWN buttons to adjust the intensity.
4. When "uxxx" is displayed you are in White dimming mode. Press the UP and DOWN buttons to adjust the intensity.
5. When "Axxx" is displayed you are in Amber dimming mode. Press the UP and DOWN buttons to adjust the intensity.
6. When "Uxxx" is displayed you are in UV dimming mode. Press the UP and DOWN buttons to adjust the intensity.

Static Color Mode:

1. Plug the fixture in and press the MODE button until "C-xx" is displayed. "xx" is the number of currently selected color.
2. There are 64 colors to choose from. Select your desired color by pressing the UP and DOWN buttons.

OPERATING INSTRUCTIONS

Program Mode: In this mode you can choose 1 of 7 programs to run. The fade speed and program speed are both adjustable.

1. Plug the fixture in and press the MODE button until “P-xx” is displayed. “xx” is the currently selected program number.
2. Use the UP or DOWN button to find your desired program.
3. Press the ENTER button to adjust the fade speed, “00” being the slowest, “30” the fastest.
4. Press the ENTER button again to adjust the color change speed, “00” being the slowest, “30” the fastest.
 - P-01 - 64 Color Change with Fade Control
 - P-02 - 64 Color Change No Fade
 - P-03 - 64 Color Fade
 - P-04 - 6 Color Change No Fade
 - P-05 - 6 Color Change With Fade
 - P-06 - 64 Color Fade with Sound Control
 - P-07 - 64 Color Change with Sound Control

Sound Active Mode: In this mode the 18P Hex will react to sound, and chase through the different colors.

1. Plug the fixture in and press the MODE button until “Soxx” is displayed. “xx” represents the sound sensitivity level.
2. Use the UP and DOWN buttons to adjust the sensitivity. “00” is the lowest sensitivity, “30” is the highest.

Activate RF Control: This function is used to activate and deactivate the RF Remote Control. When this function is activated you can control the fixture using the Dotz Par RF remote. Please see the **Dotz Par RF Operation** section of this manual for details.

1. Plug the fixture in and press the MODE button until “rFxx” is displayed. “xx” represents either “on” or “off”.
2. Press the UP or DOWN buttons to either activate the remote function (On) or deactivate it (Off).

Dimmer Curve: This is used to set the dimmer curve used with DMX mode. See the **Dimmer Curve Chart** section of this manual for more information.

1. Plug the fixture in and press the MODE button until the DMX address is displayed.
2. Press the ENTER button until “dCxx” is displayed. This is the dimmer setting. “xx” represents the currently selected dimming mode.
3. Use the UP and DOWN buttons to find your desired dimmer curve. Press SET UP when you are finished.
 - dC00 - Standard
 - dC01 - Stage
 - dC02 - TV
 - dC03 - Architectural
 - dC04 - Theater

OPERATING INSTRUCTIONS

DMX State: This mode is used as a precaution mode, that in case the DMX signal is lost, the operating mode chosen in this setup is the running mode the fixture will go into when the DMX signal is lost. You can also set this as the operating mode you would like the unit to return to when power is applied.

1. Press the MODE button until the DMX address is displayed. Press the ENTER button until either “Soun,” “HOLd,” or “bLC” is displayed.
2. Use the UP or DOWN buttons to find the desired mode of operation in the event that the DMX connection is lost.
 - “bLC” (Blackout) - If the DMX signal is lost or interrupted, the unit will automatically go into stand by mode.
 - “HOLd” (Last State) - If the DMX signal is lost or interrupted, the fix-ture will stay in the last DMX set up. If power is applied and this mode is set, the unit will automatically go into the last DMX set up.
 - “Soun” (Sound Active) - If the DMX signal is lost or interrupted, the unit will automatically go into sound active mode.
3. Find your desired setting and press ENTER. Your setting will be saved automatically.

PRIMARY-SECONDARY CONFIGURATION

This function will allow you to link units together to run in a Primary-Secondary mode. In Primary-Secondary operation, one unit will act as the controlling unit and the others will react to the controlling unit's built-in programs. Any unit can act as a Primary or as a Secondary, but only one unit can be programmed to act as the "Primary."

Primary-Secondary Connections and Settings:

1. Daisy chain your units via the XLR connector on the rear of the unit. Use standard XLR data cables to link your units together. Remember that the Male XLR connector is the input and the Female XLR connector is the output. The first unit in the chain (primary) will use the female XLR connector only. The last unit in the chain will use the male XLR connector only.
2. Set the "Primary" unit to your desired mode of operation.
3. Connect the first "Secondary" unit to the "Primary."
4. On the "Secondary" unit press the MODE button until "SEcd" is displayed. The "Secondary" unit will now follow the "Primary".

MULTIPLE UNIT POWER LINKING

With this feature you can connect the fixtures to one another using the power input and output sockets. The maximum quantity that can be connected in this manner is as follows:

- **4 fixtures maximum for 120V**
- **8 fixtures maximum for 240V**

DO NOT EXCEED THE NUMBER OF UNITS AS LISTED ABOVE.

NOTE: USE CAUTION WHEN POWER LINKING OTHER FIXTURES TO THE 18P HEX. POWER CONSUMPTION OF OTHER LIGHTING FIXTURES WILL VARY. ALWAYS CHECK THE MAX AMP OUT RATING OF EACH FIXTURE!

DOTZ PAR RF OPERATION

The Dotz Par RF remote (sold separately) has many different functions which allow you to control the 18P HEX from a distance of up to 82 feet (25meters). To use the remote, the RF feature must first be activated on the fixture, as described in the ***Operating Instructions*** section of this manual.

BLACKOUT - Press to blackout the fixture.

FADE - Press to activate Fade Program.

COLOR - Press to activate Static Color Mode.

PROGRAMS - Press to activate Built-In Program Mode.

SOUND ACTIVE - Press to activate Sound Active Mode.

(+) (-) - Press to scroll/adjust programs, colors, and speed.

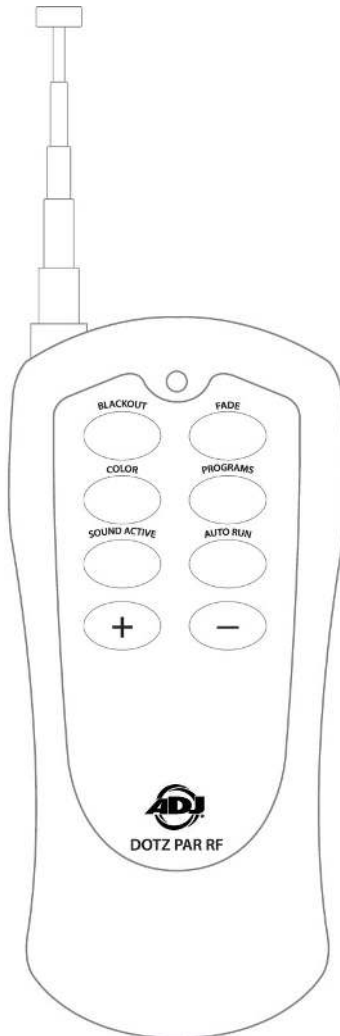

DMX TRAITS

CHANNEL				DMX VALUE	FUNCTION
6-CH	7-CH	8-CH	12-CH		
1	1	1	1	000 - 255	Red , 0% - 100%
2	2	2	2	000 - 255	Green , 0% - 100%
3	3	3	3	000 - 255	Blue , 0% - 100%
4	4	4	4	000 - 255	White , 0% - 100%
5	5	5	5	000 - 255	Amber , 0% - 100%
6	6	6	6	000 - 255	UV , 0% - 100%
	7	7	7	000 - 255	Master Dimmer , 0% - 100%
		8	8		Strobing
				000 - 031	LED Off
				032 - 063	LED On
				064 - 095	Strobing, slow to fast
				096 - 127	LED On
				128 - 159	Pulse Strobing, slow to fast
				160 - 191	LED On
				192 - 223	Random Strobe, slow to fast
				224 - 255	LED On
			9	000 - 255	Color Macros , see Color Macros Chart
			10		Programs
				000 - 020	No Program
				021 - 040	30 Color Change
				041 - 060	6 Color Change
				061 - 080	Color Fade
				081 - 100	Sound Active 30 Color Change
				101 - 120	Sound Active 6 Color Change
				121 - 140	Sound Active 6 Color Fade
				141 - 255	No Program
			11	000 - 255	Program Speed , slow to fast Sound Sensitivity , least to most sensitive
			12		Dimmer Mode
				000 - 020	Standard
				021 - 040	Stage
				041 - 060	TV
				061 - 080	Architectural
				081 - 100	Theatre
				101 - 255	Default Dimmer Setting

When Channel 10 is between the values of 21-80, Channel 11 will control the color change speed and color fade speed.
When Channel 10 is between the values of 81-140, Channel 11 will control the sound sensitivity.

COLOR MACRO CHART

COLOR NO.	DMX VALUE	RED	GREEN	BLUE	WHITE	AMBER	UV
OFF	000	0	0	0	0	0	0
Color1	001 - 004	80	255	234	80	0	0
Color2	005 - 008	80	255	164	80	0	0
Color3	009 - 012	77	255	112	77	0	0
Color4	013 - 016	117	255	83	83	0	0
Color5	017 - 020	160	255	77	77	0	0
Color6	021 - 024	223	255	8	83	0	0
Color7	025 - 028	255	243	77	77	0	0
Color8	029 - 032	255	200	74	74	0	0
Color9	033 - 036	255	166	77	77	0	0
Color10	037 - 040	255	125	74	74	0	0
Color11	041 - 044	255	97	77	74	0	0
Color12	045 - 048	255	71	77	71	0	0
Color13	049 - 052	255	83	134	83	0	0
Color14	053 - 056	255	93	182	93	0	0
Color15	057 - 060	255	96	236	96	0	0
Color16	061 - 064	238	93	255	93	0	0
Color17	065 - 068	196	87	255	87	0	0
Color18	069 - 072	150	90	255	90	0	0
Color19	073 - 076	100	77	255	77	0	0
Color20	077 - 080	77	100	255	77	0	0
Color21	081 - 084	67	148	255	67	0	0
Color22	085 - 088	77	195	255	77	0	0
Color23	089 - 092	77	234	255	77	0	0
Color24	093 - 096	158	255	144	144	0	0
Color25	097 - 100	255	251	153	153	0	0
Color26	101 - 104	255	175	147	147	0	0
Color27	105 - 108	255	138	186	138	0	0
Color28	109 - 112	255	147	251	147	0	0
Color29	113 - 116	151	138	255	138	0	0
Color30	117 - 120	100	138	255	138	0	0
Color31	121 - 124	138	169	255	138	0	0
Color32	125 - 128	255	255	255	255	0	0

CAD DRAWING

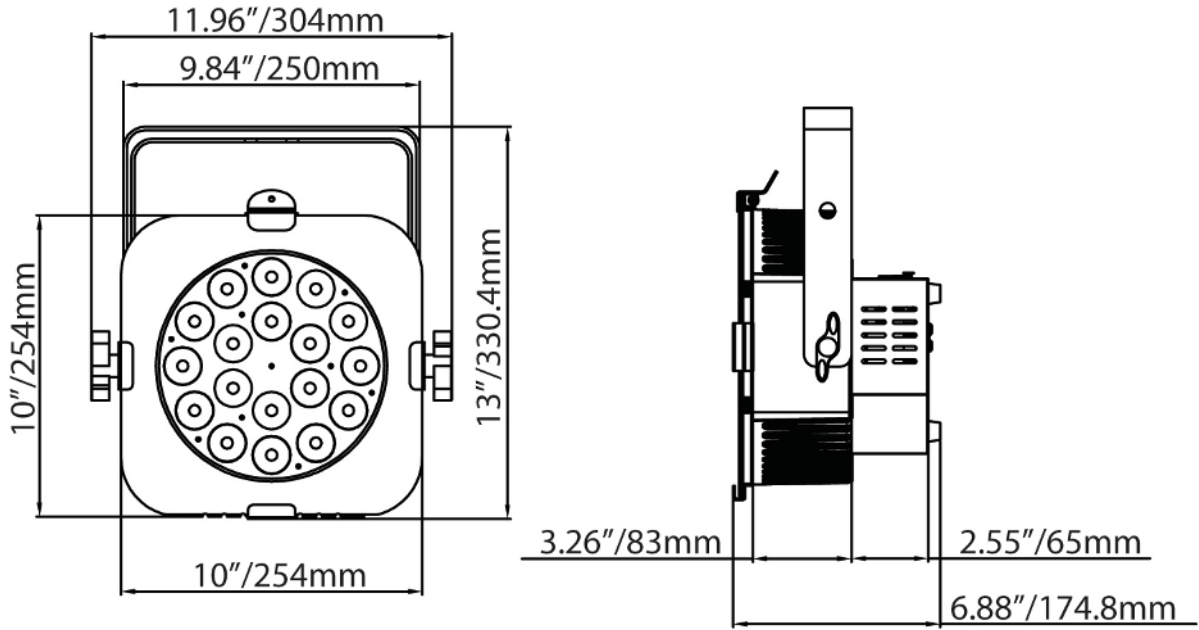

DIMMER CURVE CHART

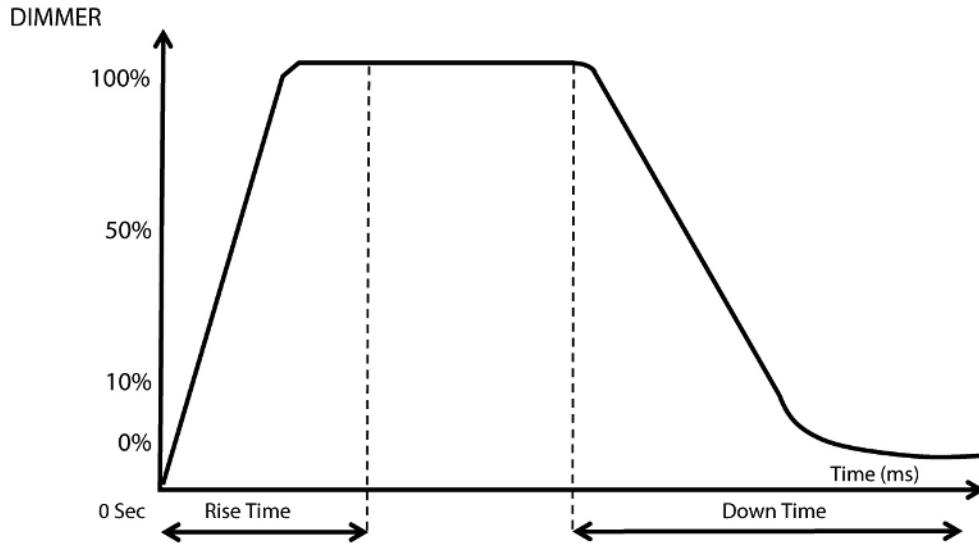

Dimming Curve Ramp Effect	0 sec Fade Time		1 sec Fade Time	
	Rise Time (ms)	Down Time (ms)	Rise Time (ms)	Down Time (ms)
Standard (default)	0	0	0	0
Stage	780	1100	1540	1660
TV	1180	1520	1860	1940
Architectural	1380	1730	2040	2120
Theatre	1580	1940	2230	2280

FUSE REPLACEMENT

Disconnect the unit from its power source. Remove the power cord from the unit. Once the cord has been removed, use a flat head screw-driver to unscrew the fuse holder, then remove the fuse holder and replace the bad fuse with new fuse. Replace the fuse holder and use the screws to secure the fuse holder in place.

TROUBLE SHOOTING

Listed below are a few common problems the user may encounter, with solutions.

Unit not responding to DMX:

Check that the DMX cables are connected properly and are wired correctly (pin 3 is “hot”; on some other DMX devices pin 2 may be ‘hot’). Also, check that all cables are connected to the right connectors, as the order in which they are connected can affect the operation of the device.

Unit does not respond to sound:

- Quiet or high pitched sounds will not activate the unit.
- Make sure that Sound Active mode is activated.

CLEANING

Due to fog residue, smoke, and dust cleaning the internal and external optical lenses must be carried out periodically to optimize light output.

- Use normal glass cleaner and a soft cloth to wipe down the outside casing.
- Clean the external optics with glass cleaner and a soft cloth every 20 days.
- Always be sure to dry all parts completely before plugging the unit back in.

Cleaning frequency depends on the environment in which the fixture operates (i.e. smoke, fog residue, dust, dew).

WARRANTY

- A. ADJ Products, LLC hereby warrants, to the original purchaser, ADJ Products, LLC products to be free of manufacturing defects in material and workmanship for a prescribed period from the date of purchase (see specific warranty period on reverse). This warranty shall be valid only if the product is purchased within the United States of America, including possessions and territories. It is the owner's responsibility to establish the date and place of purchase by acceptable evidence, at the time service is sought.
- B. For warranty service, you must obtain a Return Authorization number (RA#) before sending back the product—please contact ADJ Products, LLC Service Department at 800-322-6337. Send the product only to the ADJ Products, LLC factory. All shipping charges must be pre-paid. If the requested repairs or service (including parts replacement) are within the terms of this warranty, ADJ Products, LLC will pay return shipping charges only to a designated point within the United States. If the entire instrument is sent, it must be shipped in its original package. No accessories should be shipped with the product. If any accessories are shipped with the product, ADJ Products, LLC shall have no liability whatsoever for loss of or damage to any such accessories, or for the safe return thereof.
- C. This warranty is void if the serial number has been altered or removed; if the product is modified in any manner which ADJ Products, LLC concludes, after inspection, affects the reliability of the product, if the product has been repaired or service by anyone other than ADJ Products, LLC factory unless prior written authorization was issued to purchaser by ADJ Products, LLC; if the product is damaged because not properly maintained as set forth in the instruction manual.
- D. This is not a service contract, and this warranty does not include maintenance, cleaning or periodic check up. During the period specified above, ADJ Products, LLC will replace defective parts at its expense with new or refurbished parts, and will absorb all expenses for warranty service and repair labor by reason of defects in material or workmanship. The sole responsibility of ADJ Products, LLC under this warranty shall be limited to the repair of the product, or replacement thereof, including parts, at the sole discretion of ADJ Products, LLC. All products covered by this warranty were manufactured after August 15, 2012, and bear identifying marks to that effect.
- E. ADJ Products, LLC reserves the right to make changes in design and/or improvements upon its products without any obligation to include these changes in any products theretofore manufactured.
- F. No warranty, whether expressed or implied, is given or made with respect to any accessory supplied with products described above. Except to the extent prohibited by applicable law, all implied warranties made by ADJ Products, LLC in connection with this product, including warranties of merchantability or fitness, are limited in duration to the warranty period set forth above. And no warranties, whether expressed or implied, including warranties of merchantability or fitness, shall apply to this product after said period has expired. The consumer's and/or Dealer's sole remedy shall be such repair or replacement as is expressly provided above; and under no circumstances shall ADJ Products, LLC be liable for any loss or damage, direct or consequential, arising out of the use of, or inability to use, this product.

This warranty is the only written warranty applicable to ADJ Products, LLC Products and supersedes all prior warranties and written descriptions of warranty terms and conditions heretofore published.

LIMITED WARRANTY PERIODS

- **Non L.E.D. Lighting Products = 1-year (365 days) Limited Warranty** (Such as: Special Effect Lighting, Intelligent Lighting, UV lighting, Strobes, Fog Machines, Bubble Machines, Mirror Balls, Par Cans, Trussing, Lighting Stands etc. excluding LED and lamps)
- **Laser Products = 1 Year (365 Days) Limited Warranty** (excludes laser diodes which have 6 month limited warranty)
- **L.E.D. Products = 2-year (730 days) Limited Warranty** (excluding batteries which have a 180 day limited warranty) Note: 2 Year Warranty only applies to purchases within the United States.
- **StarTec Series = 1 Year Limited Warranty** (excluding batteries which have a 180 day limited warranty)
- **ADJ DMX Controllers = 2 Year (730 Days) Limited Warranty**

SPECIFICATIONS

Model:	18P Hex
Voltage:	100V ~ 240V / 50~60 Hz
LEDs:	18 x 12W 6-in-1 Hex LEDs
Working Position:	Any safe working position
Power Draw:	155W
Power Cord Daisy Chain:	7 Fixtures Max (120V - 10 Amps) 16 Fixtures Max (240V - 11 Amps)
Fuse:	2 Amp
Weight:	12.9 lbs. / 5.9 Kgs.
Dimensions:	11.96" (L) x 6.88" (W) x 13" (H) 304mm x 174.8mm x 330.4mm
Colors:	RGBAW + UV Color Mixing
DMX Channels:	4 DMX Modes: 6-, 7-, 8-, and 12-channel mode
Warranty:	2 Year (730 Days)
Control:	DMX, RDM (Remote Device Management)

Auto Sensing Voltage: *This fixture contains an automatic voltage switch, which will automatically sense the voltage when it is plugged into the power source.*

Please Note: Specifications and improvements in the design of this unit and this manual are subject to change without any prior written notice.

Follow Us!



[Facebook.com/adjlighting](https://www.facebook.com/adjlighting)
[YouTube.com/adjlighting](https://www.youtube.com/adjlighting)

[Twitter.com/adjlighting](https://twitter.com/adjlighting)
[Instagram: adj_lighting](https://www.instagram.com/adj_lighting)

ADJ Products, LLC
6122 S. Eastern Ave. Los Angeles, CA 90040 USA
Tel: 323-582-2650 / Fax: 323-582-2941
www.adj.com / info@americandj.com

A.D.J. Supply Europe B.V.
Junostraat 2
6468 EW Kerkrade The Netherlands
www.adj.eu / support@adjgroup.eu
Tel: +31 45 546 85 00 / Fax: +31 45 546 85 99

