



INNO POCKET SCAN



User Manual

©2022 ADJ Products, LLC all rights reserved. Information, specifications, diagrams, images, and instructions herein are subject to change without notice. ADJ Products, LLC logo and identifying product names and numbers herein are trademarks of ADJ Products, LLC. Copyright protection claimed includes all forms and matters of copyrightable materials and information now allowed by statutory or judicial law or hereinafter granted. Product names used in this document may be trademarks or registered trademarks of their respective companies and are hereby acknowledged. All non-ADJ Products, LLC brands and product names are trademarks or registered trademarks of their respective companies.

ADJ Products, LLC and all affiliated companies hereby disclaim any and all liabilities for property, equipment, building, and electrical damages, injuries to any persons, and direct or indirect economic loss associated with the use or reliance of any information contained within this document, and/or as a result of the improper, unsafe, insufficient and negligent assembly, installation, rigging, and operation of this product.

Europe Energy Saving Notice

Energy Saving Matters (EuP 2009/125/EC)

Saving electric energy is a key to help protecting the environment. Please turn off all electrical products when they are not in use. To avoid power consumption in idle mode, disconnect all electrical equipment from power when not in use. Thank you!

GENERAL INFORMATION

Unpacking: Thank you for purchasing the Inno Pocket Scan by ADJ Products, LLC. Every Inno Pocket Scan has been thoroughly tested and has been shipped in perfect operating condition. Carefully check the shipping carton for damage that may have occurred during shipping. If the carton appears to be damaged, carefully inspect your fixture for any damage and be sure all equipment necessary to operate the unit has arrived intact. In the event that damage has been found or parts are missing, please contact our toll free customer support number for further instructions. Please do not return this unit to your dealer without contacting customer support first.

Introduction: The Inno Pocket Scan is a mini DMX intelligent LED scanner. The Inno Pocket Scan has 6 DMX channels. The Inno Pocket Scan has three operating modes: sound active mode, show mode, and DMX control. The Inno Pocket Scan can operate as a stand alone fixture or in a Primary/Secondary configuration. For best results use fog or special effects smoke to enhance the projections.

Customer Support: ADJ Products, LLC provides a toll free customer support line, to provide set up help and to answer any questions should you encounter problems during your set up or initial operation. You may also visit us on the web at www.adj.com for any comments or suggestions. Service Hours are Monday through Friday 8:00 a.m. to 4:30 p.m. Pacific Standard Time.

Voice: (323) 582-2650
Fax: (323) 582-2941
E-mail: support@adj.com

To purchase parts online visit parts.adj.com.

Warning! To prevent or reduce the risk of electrical shock or fire, do not expose this unit to rain or moisture.

Warning! *This may cause severe eye damage. Never look directly into the light source!*

GENERAL INSTRUCTIONS

To optimize the performance of this product, please read these operating instructions carefully to familiarize yourself with the basic operations of this unit. These instructions contain important safety information regarding the use and maintenance of this unit. Please keep this manual with the unit for future reference.

FEATURES

- 6 DMX Channels
- 3 Operating Modes - Sound Active Mode, Show Mode, & DMX Control
- Internal Microphone
- Digital Display for Address and Function Setting
- 12 Preprogrammed Shows
- 8 fixed Gobos/Colors + Spot/White
- Power Cord Daisy Chain (See **Power Cord Daisy Chain** section of this manual)
- UC IR Compatible (Sold Separately)

WARRANTY REGISTRATION

The Inno Pocket Scan carries a 2 year (730 days) limited warranty. Please fill out the enclosed warranty card to validate your purchase and warranty. You may also register your product online at www.adj.com. All returned service items, whether under warranty or not, must be freight pre-paid and accompanied by a return authorization (R.A.) number. If the unit is under warranty, you must provide a copy of your proof of purchase invoice. Please contact ADJ customer support for an R.A. number.

HANDLING PRECAUTIONS

Caution! There are no user serviceable parts inside this unit. Do not attempt any repairs yourself, as doing so will void your manufacturer's warranty. In the unlikely event that your unit requires service, please contact ADJ Products, LLC.

During operation the housing may become extremely hot. Avoid touching the unit with bare hands while in use.

ADJ will not accept any liability for any resulting damages caused by the non-observance of this manual or any unauthorized modification to this unit.

SAFETY PRECAUTIONS

For Your Own Personal Safety, Please Read and Understand This Manual In Its Entirety Before You Attempt To Install Or Operate This Unit!

- To reduce the risk of electrical shock or fire, do not expose this unit rain or moisture
- Do not spill water or other liquids into or on to your unit.
- Do not attempt to operate this unit if the power cord is frayed or broken.
- Do not attempt to remove or break off the ground prong from the electrical cord. This prong is used to reduce the risk of electrical shock and fire in case of an internal short.
- Disconnect from main power before making any type of connection.
- Do not remove the cover for any reason. There are no user serviceable parts inside.
- Never operate this unit with the cover removed.
- Always be sure to mount this unit in an area that will allow proper ventilation. Allow about 6” (15cm) between this device and a wall.
- Do not attempt to operate this unit if it has been damaged in any way.
- This unit is intended for indoor use only. Use of this product outdoors voids all warranties.
- Always mount this unit in safe and stable matter.
- Power-supply cords should be routed so that they are not likely to be walked on or pinched by items placed upon or against them. Particular attention should be paid to cords at plugs, convenience receptacles, and the point where they exit from the appliance.
- **Cleaning** - The fixture should be cleaned only as recommended by the manufacturer. See the **Cleaning** section of this manual for details.
- **Heat** - This fixture should be situated away from heat sources such as radiators, heat registers, stoves, or other appliances (including amplifiers) that produce heat.
- The fixture should be serviced by qualified service personnel when:
 - A. Objects have fallen onto, or liquid has been spilled into, the appliance.
 - B. The appliance has been exposed to rain or water.
 - C. The appliance does not appear to operate normally or exhibits a marked change in performance.

SET UP

Power Supply: The ADJ Inno Pocket Scan contains an automatic voltage switch, which will automatically sense the voltage when it is plugged into a power source. With this switch there is no need to worry about the correct power voltage, and this unit can be plugged in anywhere.

DMX-512: DMX is short for Digital Multiplex. This is a universal protocol used by most lighting and controller manufacturers as a form of communication between intelligent fixtures and controllers. A DMX controller sends DMX data instructions from the controller to the fixture. DMX data is sent as serial data that travels from fixture to fixture via the DATA “IN” and DATA “OUT” XLR terminals located on all DMX fixtures (most controllers only have a DATA “OUT” terminal).

DMX Linking: DMX is a language allowing all makes and models of different manufacturers to be linked together and operate from a single controller, as long as all fixtures and the controller are DMX compliant. To ensure proper DMX data transmission, try to use the shortest cable path possible when linking multiple fixtures. The order in which fixtures are connected in a DMX line does not influence the DMX addressing. For example: a fixture assigned a DMX address of 1 may be placed anywhere in a DMX line, at the beginning, at the end, or anywhere in the middle. When a fixture is assigned a DMX address of 1, the DMX controller knows to send DATA assigned to address 1 to that unit, no matter where it is located in the DMX chain.

Data Cable (DMX Cable) Requirements (For DMX and Primary/Secondary Operation): The Inno Pocket Scan can be controlled via DMX-512 protocol. The Inno Pocket Scan is a 6 channel DMX unit. The DMX address is set electronically using the controls on the side panel of the unit. Your unit and your DMX controller require a approved DMX-512 110 Ohm Data cable for data input and data output (Figure 1). We recommend Accu-Cable DMX cables. If you are making your own cables, be sure to use standard 110-120 Ohm shielded cable (This cable may be purchased at almost all professional sound and lighting stores). Your cables should be made with a male and female XLR connector on either end of the cable. Also remember that DMX cable must be daisy chained and cannot be split.



Figure 1

SET UP

Notice: Be sure to follow figures two and three when making your own cables. Do not use the ground lug on the XLR connector. Do not connect the cable's shield conductor to the ground lug or allow the shield conductor to come in contact with the XLR cable's outer casing. Grounding the shield could cause a short circuit and erratic behavior.

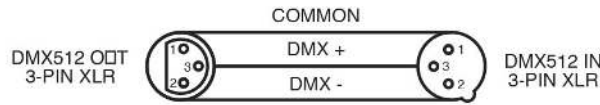

Figure 2

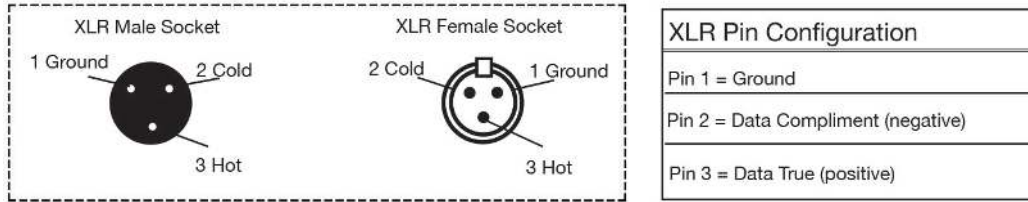
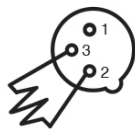

Figure 3

Special Note: Line Termination. When longer runs of cable are used, you may need to use a terminator on the last unit to avoid erratic behavior. A terminator is a 110-120 ohm 1/4 watt resistor which is connected between pins 2 and 3 of a male XLR connector (DATA+ and DATA-). This unit is inserted in the female XLR connector of the last unit in your daisy chain to terminate the line. Using a cable terminator (ADJ part number **Z-DMX/T**) will decrease the chances of erratic behavior.



Termination reduces signal errors and avoids signal transmission problems and interference. It is always advisable to connect a DMX terminal, (Resistance 120 Ohm 1/4 W) between PIN 2 (DMX-) and PIN 3 (DMX +) of the last fixture.

Figure 4

5-Pin XLR DMX Connectors. Some manufacturers use 5-pin DMX-512 data cables for DATA transmission in place of 3-pin. 5-pin DMX fixtures may be implemented in a 3-pin DMX line. When inserting standard 5-pin data cables in to a 3-pin line a cable adaptor must be used. These adaptors are readily available at most electronics stores. The chart below details a proper cable conversion.

3-Pin XLR to 5-Pin XLR Conversion		
Conductor	3-Pin XLR Female (Out)	5-Pin XLR Male (In)
Ground/Shield	Pin 1	Pin 1
Data Compliment (- signal)	Pin 2	Pin 2
Data True (+ signal)	Pin 3	Pin 3
Not Used		Pin 4 - Do Not Use
Not Used		Pin 5 - Do Not Use

SYSTEM MENU

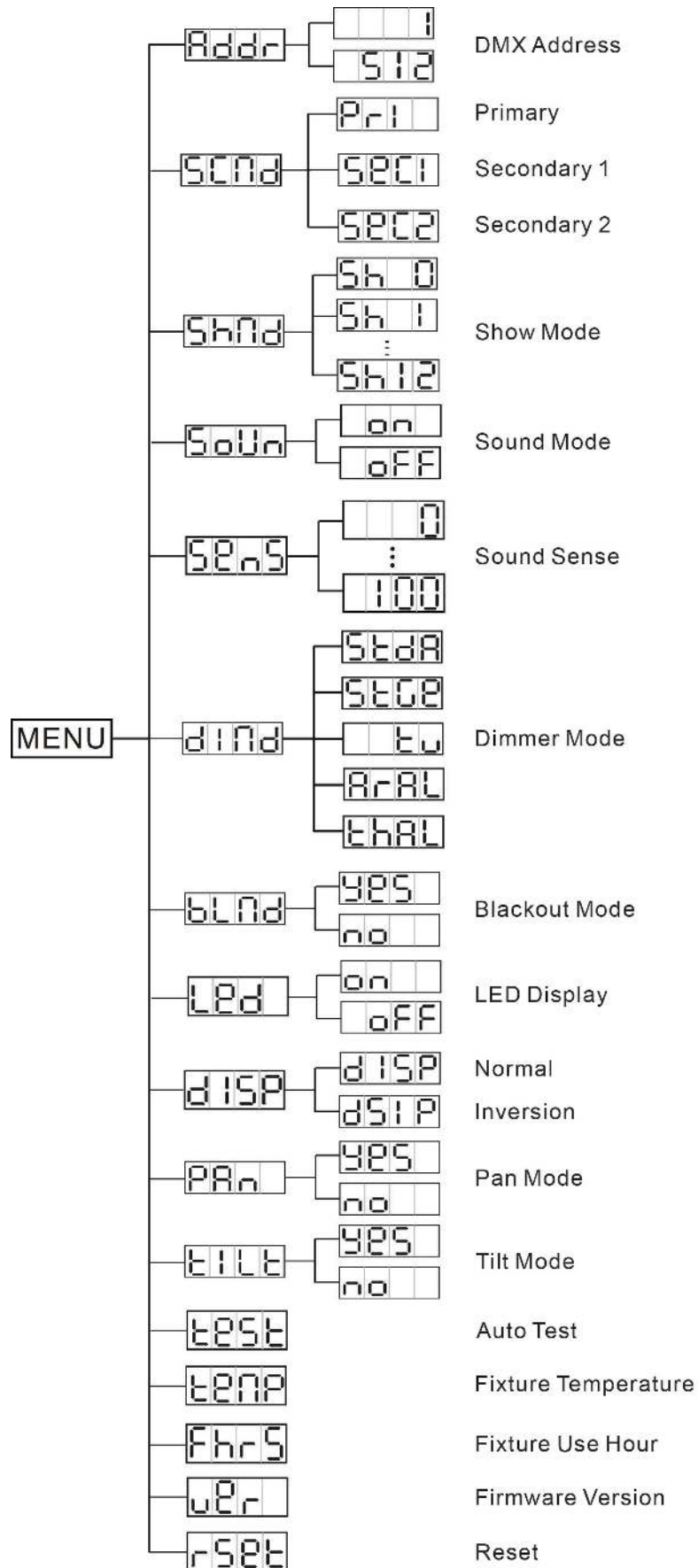

SYSTEM MENU

ADDR - DMX Address Setting.

1. Press the MENU button until “ADDR” is displayed, and press ENTER.
2. The current address will now be displayed and flashing. Press the UP or DOWN buttons to find your desired address. Press ENTER when you have found your desired DMX address, then press and hold the MENU button for at least 3 seconds to set your desired DMX address.
3. Connect your DMX Controller.

SCND - This will let you set unit as a secondary in a primary/secondary configuration.

1. Press the MENU button until “SCND” is displayed, press ENTER. Either “PRI”, “SEC1”, or “SEC2” will be displayed.
2. Press the UP or DOWN buttons until your desired setting is displayed, and press ENTER to confirm.

NOTE: Selecting “SEC2” on a fixture will cause that fixture to move in contrast to the primary fixture.

SHND: SH 0 - SH12 - Show modes 0-12 (Factory programs). Show mode can run with or without sound active mode active.

1. Press the MENU button until “SHND” is displayed, and press ENTER.
2. “Sh X” will now be displayed, “X” representing a number between 0-12. Programs 1-12 are factory programs, while “Sh 0” is random mode. Press the UP or DOWN buttons to find your desired show.
3. When you have found your desired show press ENTER, then press and hold the MENU button for at least 3 seconds to activate. After you have set your desired show, it can be changed at any time using the UP or DOWN buttons.

SOUN - Sound Active mode.

1. Press the MENU button until “SOUN” is displayed, and press ENTER.
2. The display will show either “ON” or “OFF”. Press the UP or DOWN buttons to select “ON” to activate sound active mode, or “OFF” to deactivate sound active mode.
3. Press ENTER, then press and hold the MENU button for at least 3 seconds to activate.

SENS - In this mode you can adjust the sound sensitivity.

1. Press the MENU button until “SENS” is displayed, and press ENTER.
2. A number between 0-100 will be displayed. Press the UP or DOWN buttons to adjust the sound sensitivity. 0 is the least sensitive, and 100 is the most sensitive.
3. When you have found your desired setting press ENTER to confirm.

DIND - In this mode you can select the dimmer curve.

1. Press the MENU button until “DIND” is displayed, and press ENTER.
2. The current dimmer curve setting will be displayed.
3. Press the UP or DOWN buttons to find your desired dimmer curve and press ENTER to confirm. See the **Dimmer Curve Chart** section of this manual for more information.

SYSTEM MENU

BLND - Blackout or Stand by mode.

1. Press the MENU button until “BLND” is displayed, and press ENTER. Either “Yes” or “No” will be displayed.
2. To activate Blackout tap the UP or DOWN buttons until “Yes” is displayed, and press ENTER to confirm. The fixture will now be in Blackout mode. To deactivate Blackout mode, select “No” and press ENTER.

LED - With this function you can have the LED display turn off after 10 seconds.

1. Press the MENU button until “LED” is displayed, and press ENTER.
2. The display will show either “ON” or “OFF”. Press the UP or DOWN buttons to select “ON” to keep the LED display on at all times, or “OFF” to switch to have the LED display switch off after 10 seconds of inactivity.
3. Press ENTER to confirm. To make the LED display reappear after it has turned off, press any button.

DISP - This function will reverse the display 180°.

1. Press the either the MENU button until “DISP” is displayed, and press ENTER.
2. Press the UP button to select “DSIP” to invert the display, or “DISP” to change the display back.
3. Press ENTER to confirm.

PAN - Pan Inversion.

1. Press the MENU button until “PAN” is displayed, and press ENTER. Either “Yes” or “No” will be displayed.
2. To activate the Pan inversion press the UP or DOWN buttons until “YES” is displayed, and press ENTER to confirm. To deactivate Pan inversion, select “NO” and press ENTER.

TILT - Tilt Inversion.

1. Press the MENU button until “TILT” is displayed, and press ENTER. Either “YES” or “NO” will be displayed.
2. To activate the Tilt inversion press the UP or DOWN buttons until “YES” is displayed, and press ENTER to confirm. To deactivate Tilt inversion, select “NO” and press ENTER.

TEST - This function will run a self test program. The test program will test pan/tilt movement and colors.

1. Press the MENU button until “TEST” is displayed, and press ENTER.
2. The fixture will now run a self test. Press MENU to exit.

TEMP - With this function you can check the temperature of the fixture.

1. Press the MENU button until “TEMP” is displayed, and press ENTER.
2. The temperature of the fixture will now be displayed. Press MENU to exit.

FHRS - With this function you can display the running time of the unit.

1. Press the MENU button until “FHRS” is displayed, and press ENTER.
2. The running time of the fixture will now be displayed. Press MENU to exit.

SYSTEM MENU

VER - With this function you can display the software version of the unit.

1. Press the MENU button until “VER” is displayed, and press ENTER.
2. The software version will now be displayed. Press MENU to exit.

RSET - Use this function to reset the unit.

1. Press the MENU button until “RSET” is displayed, and press ENTER.
2. The fixture will now reset.

OFFSET ADJUSTMENT MENU

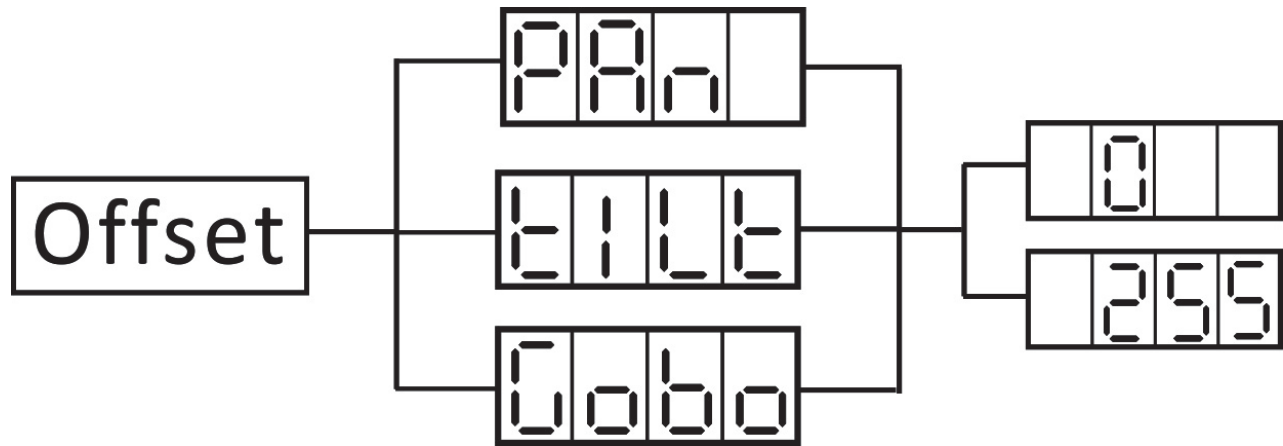

To enter the offset adjustment submenu, press the ENTER button for at least 5 seconds. In this submenu you are able to adjust the pan and tilt home positions and gobo wheel home position.

PAN - Adjustment of the pan position.

1. Press the ENTER button for at least 5 seconds, then press the UP or DOWN buttons so that "PAN" is displayed. Press ENTER.
2. Use the UP and DOWN buttons to make your adjustments, and then press ENTER to confirm.
3. Press the MENU button for one second to exit.

TILT - Adjustment of the tilt position.

1. Press the ENTER button for at least 5 seconds, then press the UP or DOWN buttons so that "TILT" is displayed. Press ENTER.
2. Use the UP and DOWN buttons to make your adjustments, and then press ENTER to confirm.
3. Press the MENU button for one second to exit.

GOBO - Adjustment of the gobo position.

1. Press the ENTER button for at least 5 seconds, then press the UP or DOWN buttons so that "GOBO" is displayed. Press ENTER.
2. Use the UP and DOWN buttons to make your adjustments, and then press ENTER to confirm.
3. Press the MENU button for one second to exit.

OPERATION

Operating Modes: *The Inno Pocket Scan can operate in three different modes. In each mode you can run the fixture as a stand alone fixture or in a primary/secondary configuration. This next section will detail the differences in the operating modes.*

- **Sound Active mode** - The fixture will react to sound, chasing through the built-in programs.
- **Show mode** - The fixture will run one of 12 shows.
- **DMX control mode** - This function will allow you to control each individual fixtures traits with a standard DMX-512 controller.

Universal DMX Control: This function allows you to use a universal DMX-512 controller to control the chases and patterns, dimmer and strobe. A DMX controller allows you to create unique programs tailored to your individual needs.

- The Inno Pocket Scan has 6 DMX Channels. See the **DMX Traits and Values** section of this manual for a detailed description of the DMX values and traits.
- To control your fixture in DMX mode, follow the set-up procedures shown in the **Set Up** section of this manual, as well as the set-up specifications that are included with your DMX controller.
- Use your DMX controller's faders to control the various DMX fixture traits.
- Follow the instructions in the **System Menu** section of this manual to set the DMX address.
- For longer cable runs (more than a 100 feet) use a terminator on the last fixture.
- For help operating in DMX mode consult the manual included with your DMX controller.

Sound Active Mode: This mode allows either a single unit or several units linked together to run to the beat of the music.

1. Press the MENU button until "SOUN" is displayed, and press ENTER. Press the UP or DOWN buttons so that "ON" is displayed and press ENTER.
2. To adjust the sound sensitivity level, press the MENU button until "SENS" is displayed, and press ENTER. Use the UP or DOWN buttons to adjust the sensitivity level. "0" is the least sensitive, and "100" is the most sensitive. Press ENTER to set your level.

Show Mode: This mode allows either a single unit or several units linked together to run one of 12 pre-programmed, selectable shows. Show mode can run with or without sound active mode.

1. Press the MENU button until "SHND" is displayed, and press ENTER.
2. Press the UP or DOWN buttons until you find your desired show, press ENTER, then press and hold the MENU button for at least 3 seconds to activate. After you have set your desired show, it can be changed at any time using the UP or DOWN buttons.

PRIMARY-SECONDARY SET UP

This function will allow you to link up to 16 units together and operate them without a controller. The units will be sound activated. In this type of set up, one unit will act as the controlling unit and the others will react to the controlling units programs. Any unit can act as a Primary or as a Secondary.

1. Using approved DMX data cables, daisy chain your units together via the XLR connector on the rear face of each unit. Remember the Male XLR connector is the input and the Female XLR connector is the output. The first unit in the chain (primary) will use the female XLR connector only, and the last unit in the chain will use the male XLR connector only. For longer cable runs, the installation of a terminator on the last fixture is highly recommended.
2. Set the Primary unit to your desired operating mode.
3. On the Secondary units tap the MENU button until “SCND” is displayed, and press ENTER.
4. Choose either “SEC1” or “SEC2” and press ENTER. See the **System Menu** section of this manual for more info.
5. The Secondary units will now follow the Primary unit.

POWER CORD DAISY CHAIN

This fixture can be linked to multiple other fixtures of the same model type using the IEC input and output sockets.

The maximum number of fixtures that can be linked in this manner is as follows:

- ***19 fixtures maximum for 120V***
- ***35 fixtures maximum for 240V***

Once this number has been reached, a new power outlet must be used in order to accommodate any additional fixtures.

All linked fixtures must be of the same make and model type. DO NOT mix fixtures.

DMX TRAITS AND VALUES

Channel	Value	Function
1	0 - 255	PAN
2	0 - 255	TILT
3	0 - 7 8 - 15 16 - 131 132 - 139 140 - 181 182 - 189 190 - 231 232 - 239 240 - 247 248 - 255	STROBE BLACKOUT OPEN STROBING SLOW - FAST OPEN SLOW OPEN - FAST CLOSE OPEN FAST OPEN - SLOW CLOSE OPEN RANDOM STROBE OPEN
4	0 - 7 8 - 14 15 - 21 22 - 28 29 - 35 36 - 42 43 - 49 50 - 56 57 - 63 64 - 71 72 - 78 79 - 85 86 - 92 93 - 99 100 - 106 107 - 113 114 - 120 121 - 127 128 - 255	COLOR WHEEL OPEN GOBO 1 YELLOW GOBO 2 RED GOBO 3 GREEN GOBO 4 BLUE GOBO 5 RGB GOBO 6 UV GOBO 7 LIGHT BLUE GOBO 8 UV & LIGHT BLUE OPEN SHAKE GOBO 1 YELLOW SHAKE GOBO 2 RED SHAKE GOBO 3 GREEN SHAKE GOBO 4 BLUE SHAKE GOBO 5 RGB SHAKE GOBO 6 UV SHAKE GOBO 7 LIGHT BLUE SHAKE GOBO 8 UV & LIGHT BLUE SHAKE GOBO WHEEL ROTATION SLOW - FAST
5	0 - 255	MASTER DIMMER 0% - 100%
6	0 - 20 21 - 40	DIMMER MODE STANDARD STAGE

DMX TRAITS AND VALUES

Channel	Value	Function
6	41 - 60 61 - 80 81 - 100 101 - 255	DIMMER MODE TV ARCHITECTURAL THEATRE DEFAULT DIMMER SETTING

UC IR REMOTE CONTROL

The **UC-IR** infrared remote gives you control of various functions. To control the fixture you must aim the remote at the front of the fixture. Maximum range is 30 feet.

STAND BY - Pressing this button will blackout the fixture.

FULL ON - Press and hold to fully illuminate the unit. The unit will return to its previous state when the button is released.

FADE/GOBO - Press this button to enter Gobo/Color mode. Use the 1-9 buttons to select your desired gobo. Adjust the output intensity using the “DIMMER +” and “DIMMER -” buttons.

“DIMMER +” and “DIMMER -” - Use these buttons to adjust the output intensity and strobe speed.

STROBE - Press and hold to activate the strobe effect.

COLOR - No defined function for this unit.

1-9 - These buttons will allow you to select either a particular gobo option or color option, depending on which operating mode the fixture is in.

SOUND ON & OFF - These buttons activate and deactivate the sound active mode.

SHOW - This activates the show mode. Use buttons 1-9 to select your desired show. To key in 0, use the “SHOW 0” button.



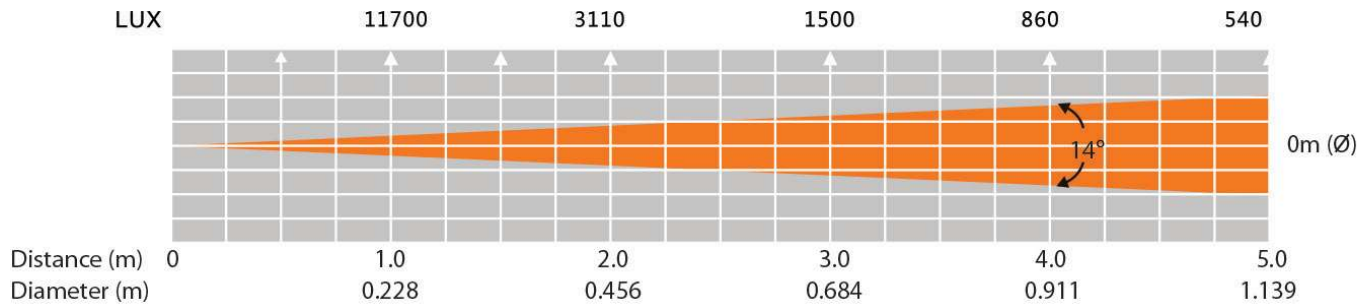

NOTE: The unit can only be controlled when it has been set to Primary mode. The unit will NOT respond to commands when it has been set to Secondary mode.

PHOTOMETRIC CHART

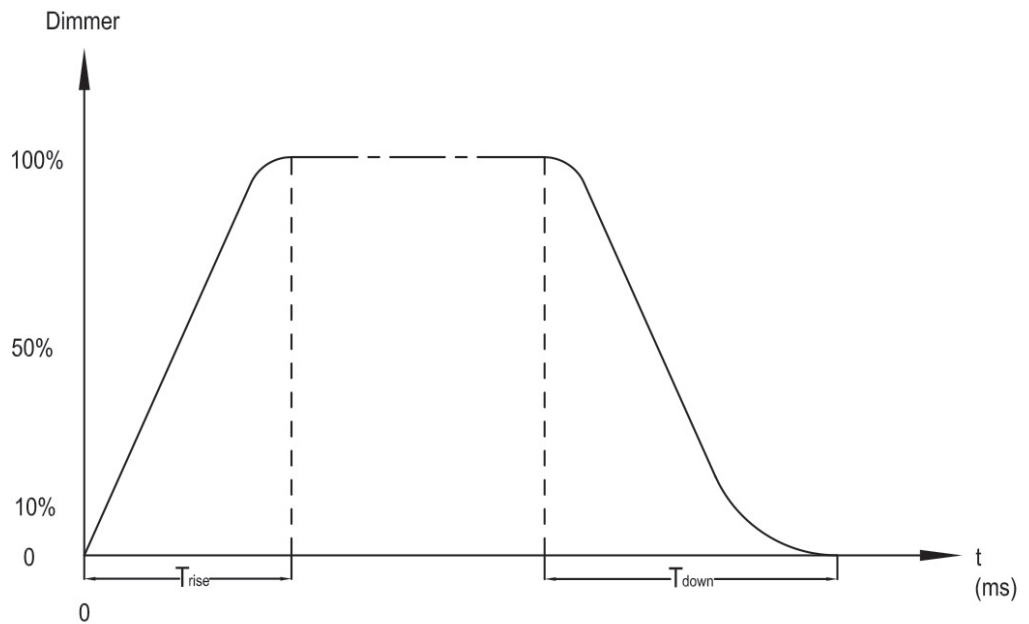

DIMMER CURVE CHART

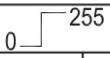

Ramp Effect	0  255 OS (Fade Time)		0  255 1S (Fade Time)	
	T _{rise} (ms)	T _{down} (ms)	T _{rise} (ms)	T _{down} (ms)
Standard	0	0	0	0
Stage	780	1100	1540	1660
TV	1180	1520	1860	1940
Architectural	1380	1730	2040	2120
Theatre	1580	1940	2230	2280

FUSE REPLACEMENT

Locate the fuse holder is located at the rear of unit next to the power cord. Using a phillips head screwdriver, remove the fuse holder. Remove the used fuse and replace with a matching fuse. Re-install the fuse holder.

CLEANING

Fixture Cleaning: Due to fog residue, smoke, and dust, cleaning the internal and external optical lenses and mirror should be carried out periodically. Cleaning frequency depends on the environment in which the fixture operates (i.e. smoke, fog residue, dust, dew). In heavy club use, cleaning on a monthly basis is recommended in order to ensure longevity and crisp output.

- Use normal glass cleaner and a soft cloth to wipe down the outside casing.
- Use a brush to wipe down the cooling vents and fan grill.
- Clean the external optics with glass cleaner and a soft cloth every 20 days.
- Clean the internal optics with glass cleaner and a soft cloth every 30-60 days.
- Always be sure to dry all parts completely before plugging the unit back in.

TROUBLE SHOOTING

Listed below are common problems that you may encounter, along with potential solutions.

No light output from the unit:

- Check that the external fuse has not blown. The fuse is located on the rear of the unit.
- Be sure the fuse holder is completely and properly seated.

Unit does not respond to sound:

- Low frequencies (bass) should cause the unit to react to sound. Quiet or high pitched sounds, such as tapping on the microphone, may not activate the unit.

WARRANTY

MANUFACTURER'S LIMITED WARRANTY:

- A. ADJ Products, LLC hereby warrants, to the original purchaser, ADJ Products, LLC products to be free of manufacturing defects in material and workmanship for a prescribed period from the date of purchase (see specific warranty period on reverse). This warranty shall be valid only if the product is purchased within the United States of America, including possessions and territories. It is the owner's responsibility to establish the date and place of purchase by acceptable evidence, at the time service is sought.
- B. For warranty service you must obtain a Return Authorization number (RA#) before sending back the product—please contact ADJ Products, LLC Service Department at 800-322-6337. Send the product only to the ADJ Products, LLC factory. All shipping charges must be pre-paid. If the requested repairs or service (including parts replacement) are within the terms of this warranty, ADJ Products, LLC will pay return shipping charges only to a designated point within the United States. If the entire instrument is sent, it must be shipped in its original package. No accessories should be shipped with the product. If any accessories are shipped with the product, ADJ Products, LLC shall have no liability whatsoever for loss of or damage to any such accessories, nor for the safe return thereof.
- C. This warranty is void if the serial number has been altered or removed; if the product is modified in any manner which ADJ Products, LLC concludes, after inspection, affects the reliability of the product; if the product has been repaired or serviced by anyone other than the ADJ Products, LLC factory unless prior written authorization was issued to purchaser by ADJ Products, LLC; if the product is damaged because not properly maintained as set forth in the instruction manual.
- D. This is not a service contract, and this warranty does not include maintenance, cleaning or periodic check up. During the period specified above, ADJ Products, LLC will replace defective parts at its expense with new or refurbished parts, and will absorb all expenses for warranty service and repair labor by reason of defects in material or workmanship. The sole responsibility of ADJ Products, LLC under this warranty shall be limited to the repair of the product, or replacement thereof, including parts, at the sole discretion of ADJ Products, LLC. All products covered by this warranty were manufactured after August 15, 2012, and bear identifying marks to that effect.
- E. ADJ Products, LLC reserves the right to make changes in design and/or improvements upon its products without any obligation to include these changes in any products theretofore manufactured.

No warranty, whether expressed or implied, is given or made with respect to any accessory supplied with products described above. Except to the extent prohibited by applicable law, all implied warranties made by ADJ Products, LLC in connection with this product, including warranties of merchantability or fitness, are limited in duration to the warranty period set forth above. And no warranties, whether expressed or implied, including warranties of merchantability or fitness, shall apply to this product after said period has expired. The consumer's and/or Dealer's sole remedy shall be such repair or replacement as is expressly provided above; and under no circumstances shall ADJ Products, LLC be liable for any loss or damage, direct or consequential, arising out of the use of, or inability to use, this product.

This warranty is the only written warranty applicable to ADJ Products, LLC Products and supersedes all prior warranties and written descriptions of warranty terms and conditions heretofore published.

MANUFACTURER'S LIMITED WARRANTY PERIODS:

- **Lighting Products = 1-year (365 days) Limited Warranty** (Such as: Special Effect Lighting, Intelligent Lighting, UV lighting, Strobes, Fog Machines, Bubble Machines, Mirror Balls, Par Cans, Trussing, Lighting Stands etc. excluding LED and lamps)
- **Laser Products = 90-Day Limited Warranty**
- **L.E.D. Products = 2-year (730 days) Limited Warranty** (excluding motors, PCB boards, and power supplies, which have a 1-year (365 day Limited Warranty) batteries which have a 180 day limited warranty). Only the L.E.D.s carry a 2-year warranty (**excluding StarTec Series which carries a 1 Year Limited Warranty**) **Note: 2 Year Warranty only applies to purchases within the United States.**
- **ADJ DMX Controllers = 2 Year (730 Days) Limited Warranty** (excluding faders and tact switches)

SPECIFICATIONS

MODEL:	Inno Pocket Scan
Voltage:	100V~240V, 50Hz/60Hz
LEDs:	1 x 12W LED
Power Consumption:	33W
Power Cord Daisy Chain:	19 Fixtures Max. (120V) 35 Fixtures Max. (230V)
Dimensions:	11.5" (L) x 5.25" (W) x 6.5" (H) 294mm x 132mm x 165mm
Weight:	6 Lbs. / 2.4 kgs.
Beam Angle:	14 Degrees
Fuse:	3.15 Amp
Duty Cycle:	None
DMX:	6 DMX Channels
Gobos/Colors:	8 Fixed Gobos/Colors + Spot/White
Sound Active:	Yes
Working Position:	Any Safe, Secure Position
Warranty:	2 Years (730 Days)

Auto Sensing Voltage: This fixture contains an automatic voltage switch, which will automatically sense the voltage when it is plugged into a power source.

Please Note: Specifications and improvements in the design of this unit and this manual are subject with change without any prior written notice.

ADJ Products, LLC
6122 S. Eastern Ave. Los Angeles, CA 90040 USA
Tel: 323-582-2650 / Fax: 323-725-6100
Web: www.adj.com / E-mail: info@americandj.com

Follow Us On:



facebook.com/americandj
twitter.com/americandj
youtube.com/adjlighting

A.D.J. Supply Europe B.V.
Junostraat 2
6468 EW Kerkrade
Netherlands
service@adjgroup.eu / www.adj.eu
Tel: +31 45 546 85 00 / Fax: +31 45 546 85 99

