

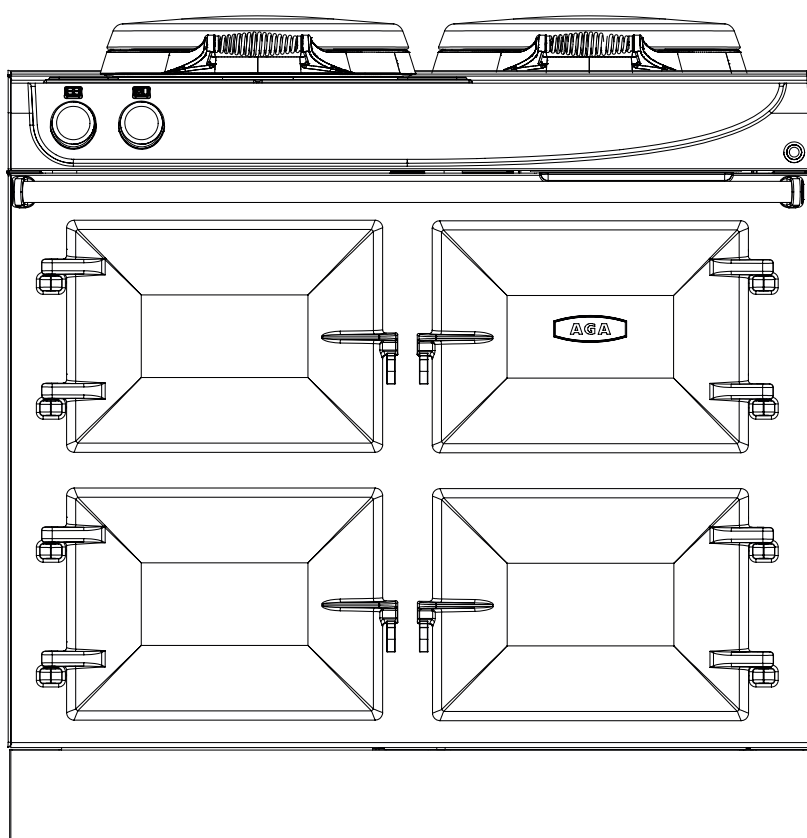

**AGA R3**  
**Model Nos**  
**R3 100-4h, Twin Dome**



**User Guide &**  
**Installation Instructions**

**CAUTION: THIS UNIT IS HEAVY, PROPER EQUIPMENT AND ADEQUATE MANPOWER MUST BE USED IN MOVING THE RANGE TO AVOID DAMAGE TO THE UNIT OR THE FLOOR.**

**REMEMBER**, when replacing a part on this appliance, use only spare parts that you can be assured conform to the safety and performance specification that we require.

**DO NOT** use reconditioned or copy parts that have not been clearly authorised by AGA.

**PLEASE READ THESE INSTRUCTIONS BEFORE USING THIS APPLIANCE  
AND KEEP IN A SAFE PLACE FOR FUTURE REFERENCE.**

## Useful Information

It maybe useful to make a note of your AGA appliance Serial Number when it is being installed.

The serial number can be found on the rear of the appliance.

## My AGA Details:

**Serial No:**

**AGA Service No:**

**AGA Dealer or store  
contact No:**

**Date of Installation:**

# Contents

<b>1. Health and Safety</b>	<b>1</b>
<b>2. Introduction</b>	<b>3</b>
<b>3. Overview 100-4H</b>	<b>4</b>
<b>4. Aga R3 General Operation Guidance</b>	<b>5</b>
<b>5. The Controls</b>	<b>6</b>
<b>6. The Ovens</b>	<b>7</b>
<b>7. The Infrared Grill</b>	<b>11</b>
<b>8. The Hotplate</b>	<b>12</b>
<b>9. Cooking table</b>	<b>13</b>
<b>10. Oven shelves</b>	<b>14</b>
<b>11. AGA accessories</b>	<b>16</b>
<b>12. Cleaning &amp; Caring</b>	<b>18</b>
<b>13. Maintenance</b>	<b>19</b>
<b>14. Installation instructions</b>	<b>20</b>
<b>15. Installation introduction</b>	<b>21</b>
<b>16. Product Dimensions R3 100-4h, Twin Dome</b>	<b>22</b>
<b>17. Electrical connection</b>	<b>25</b>
<b>18. Installation and Levelling</b>	<b>26</b>
<b>19. Control knob and handrail connection</b>	<b>27</b>
<b>20. Circuit diagrams</b>	<b>28</b>

# 1. Health and Safety

---

## Consumer Protection

As a responsible manufacturer, we take care to make sure that our products are designed and constructed to meet the required safety standards when properly installed and used.

- ⚠ Children less than 8 years of age shall be kept away unless continuously supervised. Cleaning and user maintenance MUST not be made by children without supervision.**
- ⚠ CHILDREN SHOULD BE KEPT AWAY FROM THE APPLIANCE AS SOME SURFACES CAN BECOME HOT TO THE TOUCH.**
- ⚠ WARNING: ACCESSIBLE PARTS MAY BECOME HOT DURING USE. TO AVOID BURNS AND SCALDS CHILDREN SHOULD BE KEPT AWAY.**
- ⚠ WARNING: During use the appliance becomes hot. Care should be taken to avoid touching heating elements inside the ovens.**
- ⚠ WARNING : Any spillages should be removed from the hotplate lids before they are opened.**
- ⚠ WARNING : This appliance is not intended to be operated by means of an external timer not approved by AGA or a separate remote-control system.**
- ⚠ CAUTION: The cooking process has to be supervised. A short term cooking process has to be supervised continuously.**
- ⚠ WARNING: Danger of fire: Do not store items on the cooking surfaces.**
- ⚠ WARNING: Unattended cooking on a hob with fat or oil can be dangerous and may result in fire. NEVER try to extinguish a fire with water, but switch off the appliance and then cover flame e.g. with a lid or fire blanket.**
- ⚠ IMPORTANT: Oil is a fire risk, NEVER leave pans containing oil or fat unattended during the heating or cooking period.**
- ⚠ Never fill the pan more than one-third fill of fat or oil.**
- ⚠ Installation and maintenance must be performed by a qualified installer or service agency.**
- ⚠ WARNING! This appliance must be installed with an appropriate device that will allow permanent disconnection of the Live and Neutral conductors. During Installation or disconnection prior to any electrical work, the appliance must be permanently disconnected from the Supply (Live) and Neutral Conductors.**
- ⚠ If a supply cord is damaged it must be replaced by the manufacturer, its service agent or similarly qualified persons in order to avoid a hazard.**

**This appliance operates on single phase. To adjust to 2 or 3 phase installation, an optional adapter kit must be obtained (Part No. AE4M280352).**

- ⚠ DO NOT use a steam cleaner on your cooker.**
- ⚠ To avoid overheating, DO NOT install the cooker behind a decorative door.**
- ⚠ For correct installation of the oven shelves, refer to the user instructions.**
- ⚠ DO NOT use abrasive pads, caustic cleaners, oven cleaners or metal scrapers to clean the surfaces of the enamel.**
- ⚠ IMPORTANT: AGA recommend Vitreous Enamel Association approved cleaners for cleaning the vitreous enamelled surfaces of this product.**
- ⚠ DO NOT put oven doors or resting plates in a dishwasher.**
- ⚠ Children should be supervised to ensure that they do not play with the appliance.**

## Cooker Base or Hearth

It is essential that the base or hearth on which the cooker sits should be level and capable of supporting the total weight of one or both units.

The front plinth cover is removable and must not be obstructed by flooring or tiles. If necessary the cooker must be raised by the thickness of the tiles to ensure the plinth can be removed.

The appliance can be used by children aged from 8 years and above and persons with reduced physical, sensory or mental capabilities or lack of experience and knowledge if they have been given supervision or instruction concerning use of the appliance in a safe way and understand the hazards involved.

The appliance may contain some of the materials that are indicated below. It is the Users/Installers responsibility to ensure that the necessary personal protective clothing is worn when handling where applicable, the pertinent parts that contain any of the listed materials that could be interpreted as being injurious to health and safety, see below for information.

#### **Glues and Sealants**

Exercise caution - if they are still in liquid form use face mask and disposable gloves.

#### **Glass Yarn, Mineral Wool, Insulation Pads, Ceramic Fibre**

May be harmful if inhaled. May be irritating to skin, eyes, nose and throat. When handling avoid contact with skin or eyes. Use disposable gloves, face-masks and eye protection. After handling wash hands and other exposed parts. When disposing of the product, reduce dust with water spray, ensure that parts are securely wrapped.

#### **General**

- In the event of a fire, cover the pan with a lid and switch OFF the electricity.
- Smother the flames on the hob rather than attempting to remove the pan to the outside.
- Burns and injuries are caused almost invariably by picking up the burning pan to carry outside.

#### **Deep Fat Frying**

- Use a deep pan, large enough to completely cover the appropriate heating area.

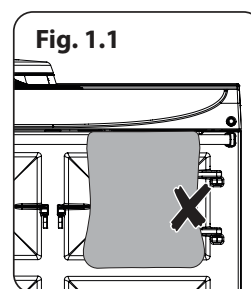

**DO NOT** hang dish towels on the right hand side of the handrail when the induction hob is in use (**Fig. 1.1**). Doing so will restrict the flow of air through the induction air outlet which could affect performance.

When the oven (s) are on **DO NOT** leave any oven door open for long periods, this will affect the temperature of the oven and may allow controls to become hot.

## 2. Introduction

---

As responsible manufacturers we take care to make sure that our products are designed and constructed to meet the required safety standards when properly installed and used.

Your AGA is a radiant heat store cooker which combines the design values and cooking principles of the traditional AGA with the flexibility to turn each cooking area off and on as you require, thereby fitting into your lifestyle beautifully.

Refer to the diagram in the Overview chapter to familiarise yourself with the product and refer to the relevant sections for upper oven, lower oven, etc.

Any alteration that is not approved by AGA could invalidate the approval of the appliance, operation of the warranty and could affect your statutory rights.

In the interests of safety and effective use, please read the following before using your new AGA appliance.

Ensure that the kitchen is well ventilated: keep natural ventilation holes open or install a mechanical ventilation device (mechanical extractor hood).

Prolonged intensive use of the appliance may call for additional ventilation, for example, opening of a window, or more effective ventilation, for example increasing the level of mechanical ventilation where present.

Installation must be to local and national wiring regulations and carried out by a qualified engineer.

A little smoke and some odour may be emitted when first switched on. This is normal and harmless (from oven lagging and starch binder on the element insulation) and will cease after a short period of use.

### 3. Overview 100-4H

Fig. 3.1

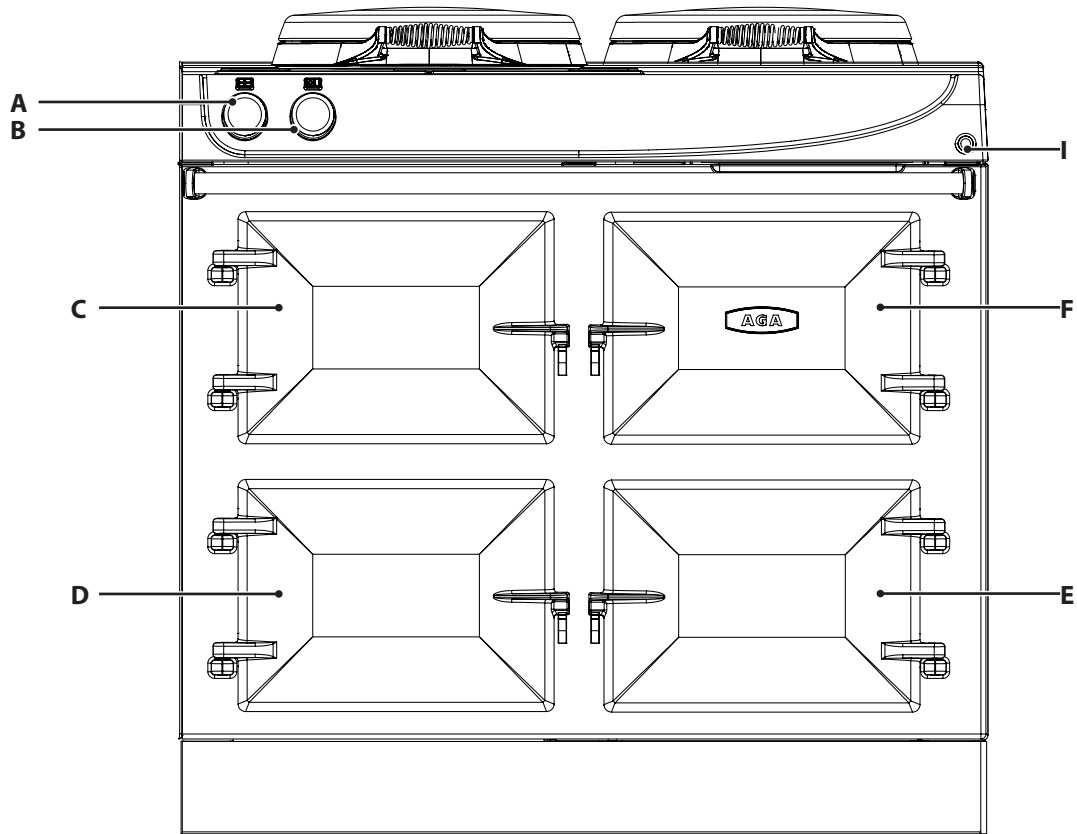

This model illustrates 100/4H

Fig. 3.2

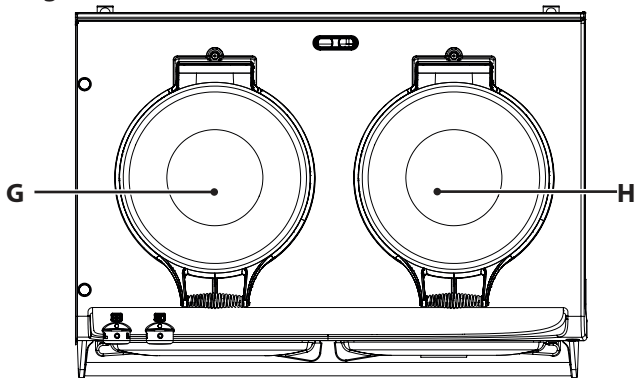

**Cooker overview Fig. 3.1**

- A. Oven and grill control
- B. Simmering and Boiling plate control
- C. Top oven - ROAST
- D. Lower oven - BAKE/SIMMER
- E. Warming oven
- F. Infrared Grill
- G. Boiling Plate
- H. Simmering Plate
- I. Warming oven switch

Refer to **page 5** to **page 13** for operation of the main cooker.

## 4. Aga R3 General Operation Guidance

---

Your new AGA cooker is a fully electric heat storage appliance. The appliance requires only a low power supply via two 13 amp connections.

The AGA R3 radiant 3 series operates like a traditional heat storage appliance which can also provide gentle background heat into your kitchen.

The AGA would typically be left at cooking temperature 24 hours a day (see details below for typical heat up times).

The R3 however is far more versatile providing additional control and flexibility, since it allows individual control of ovens and hotplates. There is also a high speed infrared grill. If desired individual functions such as hotplates and ovens can be turned off or on even down to the 'e' setting to further reduce energy usage.

### Warm up times

As the AGA works on the principle of stored radiant heat within the castings and ovens, with the lower power requirement, time is required to gather heat from the electric elements and to fully saturate each heating zone.

The following are approximate heating up times from cold.

Cast iron ROAST oven	- 2 hours 10 mins
Radiant BAKE/SIMMER oven	- 2 hours
'e' setting (Roast oven reverts to a Bake temperature and the lower oven to simmer.	- 1 hours 30 mins
Boiling plate	- 40 mins
Simmer plate	- 20 mins

## 5. The Controls

When switching on the AGA cooker for the first few times, there are two things you may notice, neither of which should cause concern.













The AGA cooker will emit an odour for a short while, this is simply due to the protective oil we put on the hotplate and ovens burning off. Due to the newness in the first couple of hours, it is advisable to open the kitchen window while this takes place.

Condensation may occur on the top and front plate whilst the AGA cooker is heating up, caused by the insulation lagging and starch binder on the element insulation drying out. The condensation should be wiped away as soon as possible to prevent staining the enamel.

Your AGA has the external appearance of a classic AGA heat storage enamelled cast iron cooker. However, it's flexibility is almost unbounded because in place of a single heat source each cooking zone has its own electrically heated cast iron element (s). The separation of cooking zones, allows a choice of control. You are able to select only the zones that you want, or need, to use.

### Cooker hoods and oven venting

**It is recommended that this AGA is fitted with a cooker hood above it. The AGA venting system is located on top of the AGA and is designed for venting the moisture from the ovens. The cooker hood should be positioned not less than the minimum height as recommended by the manufacturer, from the top of the AGA.**

Hotplate	
OFF	
Simmering	
Boiling	
Boiling and Simmering ON	
Oven & Grill	
OFF	
Roast oven ON	
Bake oven ON	
Simmer Oven ON	
Roast and Bake Ovens ON	
Roast and Simmer Ovens ON	
'e' Setting	
Grill	
Warming Oven	
Bottom Right-hand Oven ON = Green Neon	

## 6. The Ovens

The upper oven in your R3 is the traditional AGA Roast oven, manufactured from cast iron for maximum heat retention and the best radiant cooking. Over period of time they will become individually seasoned.

However, the oven will rust if high moisture content foods are not covered or spillages not cleaned up. It is also not advisable to leave full or partially filled saucepan/utensils with high moisture content in the ovens when they are not in use. To season the oven a light vegetable oil is ideal (corn oil is best) spray oil can also be recommended. Any stubborn stains can be removed with the wire brush supplied.

The lower **BAKE/SIMMER, WARMING** oven and **GRILL** compartments are enamelled and do not need to be seasoned.

### General advice

Food should not be placed into any oven until it is up to normal operating heat. The oven doors should not be left open for long periods of time during cooking and heating up.

Store the cold plain shelf outside the cooker. Use it cold in the roasting oven to deflect heat from the top of the oven, creating a more moderate oven temperature underneath. It can also be used as a baking sheet.

### Cooker overview Fig. 6.1

- A. Oven and grill control
- B. Top oven - ROAST
- C. Lower oven - BAKE/SIMMER
- D. Warming oven

Fig. 6.1

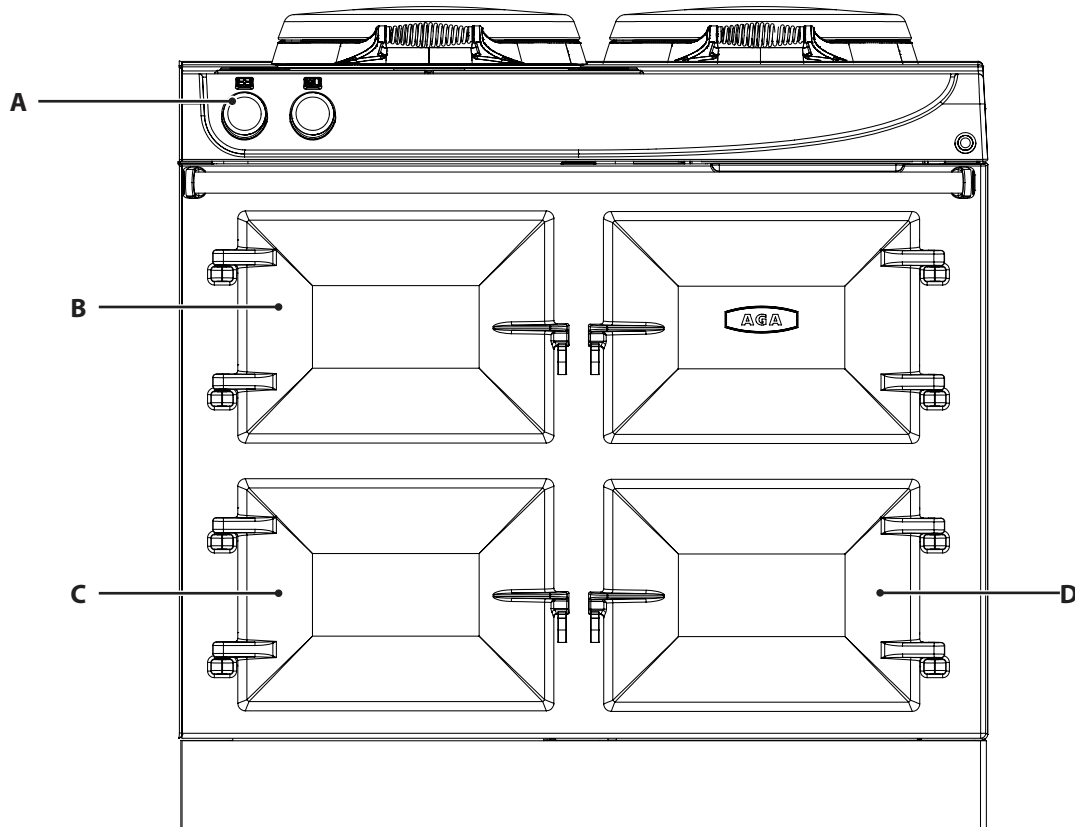

## Roasting oven setting

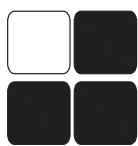

The roasting oven setting is indirectly heated by two elements, one in the base of the oven and the other in the roof. These elements heat the cast iron within to provide cooking results consistent with the traditional AGA heat-storage cooker, with the flexibility of being able to turn

the oven off when not in use.

The roasting oven setting can be used for 'grilling' at the top and 'shallow frying' on the oven floor.

When cooking on the base of the roasting oven, place the floor grid on the base before putting the food into the oven. This lifts the food away from the base element to ensure best cooking results are achieved.

The roasting oven setting is zoned in heat, meaning it is slightly hotter towards the top than the centre and the oven grid shelf set on the oven floor is slightly less hot than the centre.

The beauty of the roasting oven setting is that any fat is burnt off when the oven is at full heat, just brush out occasionally to remove the carbon deposits.

The roasting oven setting is excellent for bread and pastries. Quiches in ceramic or pies in Pyrex dishes need not be baked blind as when they are in placed on the floor grid on the base of the oven the pastry cooks from underneath and the filling will set and brown from the all-round heat. As you are aware metal flat tins conduct heat quicker than ceramic and may need less cooking time.

The specially designed AGA roasting tins and bakeware slide directly onto the runners, so almost every available square centimetre of space can be used. Food can be protected by the use of the cold plain shelf or shielded by means of the large roasting tin which means you can cook food that requires different temperatures at the same time. If food is browning too quickly and you do not want to move it to another oven just slide the cold plain shelf over the food to reduce the top heat.

**NOTE:** Always remove the cold plain shelf and roasting tins on completion of cooking.

## Baking oven setting



The baking oven is indirectly heated by one heating element under the base of the oven. Heat is then conducted around the outside by a twin wall cavity to provide full heat saturation.

This setting is a moderate heat, so is ideal for cakes, biscuits, also anything which requires medium heat such as fish pie, lasagne, soufflés, crumbles, roulades. Meat and poultry can be cooked here; most things which can be cooked in the roast oven can be cooked in the baking oven but for a longer time.

For the best results when cooking cakes do allow at least the two hour heat up time. Cook cakes together on one shelf. If two shelves are used interchange the food to achieve even colouration, as you would with any oven which is zoned heat.

For best results when cooking cakes

- place in the middle of the oven
- if more than one tray, swap cakes around towards the end of baking to even browning
- ensure space around the trays for even air flow

We do not recommend use of the cold plain shelf or the AGA full size roasting tin in this oven, as air flow could be restricted, which may affect cooking results. Instead we recommend using cookware which sits on the oven shelf and allows free air movement around the oven.

A full range of additional AGA cookware can be found at your AGA specialist, or online, at [www.agacookshop.co.uk](http://www.agacookshop.co.uk).

## Simmering oven



The lower Baking oven has 2 settings. This setting on the control will reduce the heat to a simmer setting.

The simmering oven can be described as a continuation oven, it continues to cook food that has been brought up to heat elsewhere on the cooker with

the exception of meringues which are dried out rather than 'cooked'.

### Simmer oven guidance

- Allow the ovens to heat fully, refer to heat up times **page 5**
- To get the very best performance, we recommend to use AGA cookware with thick bases and stacking lids.
- **DO NOT** place dishes directly on to the oven base. Always place onto either a shelf or the floor grid.
- Joints of meat and poultry should be brought up to heat ideally on the roasting oven setting for 30-45 minutes, then transferred to the simmering oven.
- This method is unsuitable for stuffed meat and stuffed poultry).
- Make sure that pork and poultry reach an internal temperature of at least 75°C.
- Always bring soups, casseroles and liquids to the boil before putting in the simmering oven.
- Always thaw frozen food completely before cooking.
- Root vegetables will cook better if cut into small pieces.
- Adjust seasoning and thickenings at the end of the cooking time.
- Many dried pulses and beans for example, dried red kidney beans must be boiled for a minimum of 10 minutes, after soaking, and before inclusion in any dish.

## Warming oven



The warming oven is indirectly heated by one element in the base of the oven.

The **OVEN IS NOT A HOLDING OVEN** and therefore is not designed to hold food at a given temperature for long periods.

The warming oven is designed to keep prepared food warm for a short period until it is convenient to serve.

Operate the warming oven via the separate switch at the right-hand side of the hotplate. A green neon indicates that the warming oven is on.

## The 'e' setting

The R3 has an 'e' setting which will reduce running costs and the useful heat into the room will be reduced.

The heating up time to full temperature from the 'e' setting is approximately 1 hour.

The 'e' setting will reduce the ROAST oven to a low bake temperature; the lower BAKE oven will reduce to a simmer temperature.

The cast iron upper oven is ideal for baking, especially when baking is required over longer periods for example ideal for fruit cakes

**PLEASE NOTE:** If you wish to bake in the cast roast oven when it has been at full temperature, you have to select the 'e' setting. Because of the heat retention characteristics of cast iron, the oven will hold its heat for a considerable amount of time. Therefore allow approximately 2 hours for the temperature to cool down.

## 7. The Infrared Grill



**CAUTION:** Accessible parts may be hot when the grill is in use. Young children should be kept away.

**THE GRILL DOOR MUST BE KEPT OPEN WHEN THE GRILL IS ON.**

1. When operating the grill, the cooling fan will also operate. After use the fan may continue to operate to cool the product down.
2. If you close the door in use, the grill will turn off, the fan may continue depending on how long the grill has been in use.
3. **Please Note:** when the grill is in use the power is cut to the ovens. Normal grilling unless for very long periods will not affect the heat retention in the ovens. If cooking in the ovens at the same time as operating the grill you may need to extend the cooking time.
4. For best results pre heat the grill for approximately 2 minutes.
5. The grill has 3 shelf positions (see **Fig. 7.1**)  
Use the higher positions for fast cooking  
Use the lower positions for slower cooking
6. The large grill pan/meat tin with grill rack can be stored in the base of the grill compartment, when the grill is off.

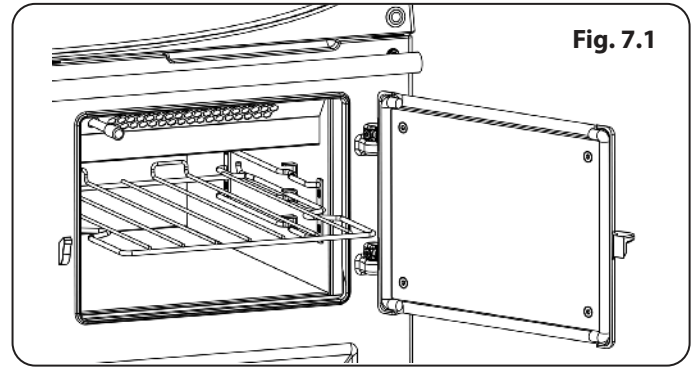

## 8. The Hotplate

Fig. 8.1

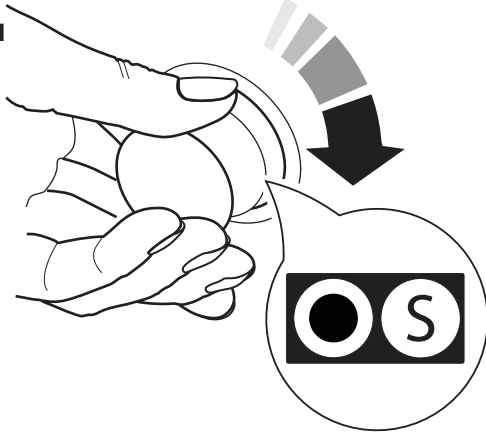
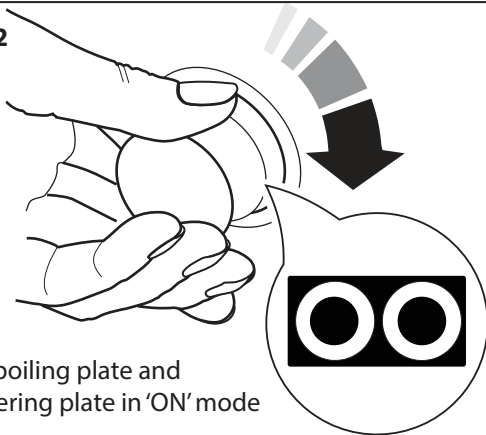
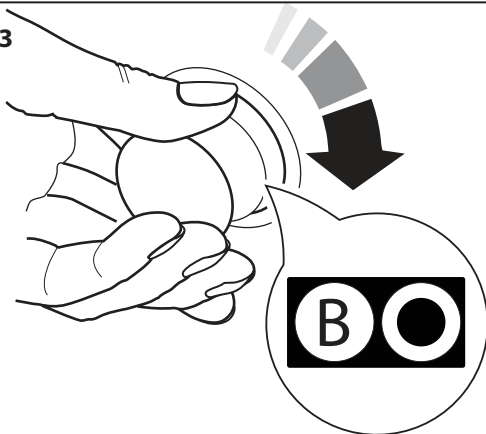

Fig. 8.2



Both boiling plate and simmering plate in 'ON' mode

Fig. 8.3



The cast iron hotplates are operated manually and are machined flat to give the best all-over contact with the AGA saucepans, grill pan, frying pan and kettle.

The boiling plate is the hottest with the simmering plate being cooler. The hotplate can be used completely independently from the ovens.

Several pans can be accommodated on the plate at any one time. The hotplate is set very slightly above the top plate to minimise scratching as the pans are pulled to one side to simmer.

The chrome insulated covers are brought down over the hotplate when it is heating up or not in use. When the hotplate is 'ON' the insulated cover will be warm. We strongly advise not to put anything such as kettles, saucepans or baking tins directly onto the insulated cover because it will show any scratches - invest in a chef's pad to protect the surface if the cover is to be used as a resting place!

Keep the hotplate clear of any burnt on food or crumbs by brushing with the wire brush, supplied with your AGA. Cleaning details can be found "**Cleaning & Caring**" on page 34.

### Hotplate Controls

#### The simmering plate setting (Fig. 8.1)

(heat up time approx 20 mins)

The simmering plate setting is the cooler of the two settings and so is used for recipes that require a lower heat such as, making sauces, scrambling eggs, heating milk, slow frying, simmering soups and root vegetables. In addition, it can be used to cook on directly as a form of griddle - invaluable for toasted sandwiches, quesadillas, drop scones, searing scallops and even a non-fat fried egg! Slow cooked toast can be made on the simmering plate setting, no need to use the AGA toaster here.

#### The boiling plate setting (Fig. 8.3)

(heat up time approx 35 mins - 40 mins)

The hottest setting, the boiling plate setting is used for boiling, grilling, stir-frying, making toast - indeed anything that requires a high heat. Green vegetables keep their colour when boiled quickly here, or use a steamer over the saucepans to cook more than one vegetable at once.

When stir-frying or cooking anything that is inclined to splash we would recommend using an AGA Splash Shield which will protect the insulated cover from splatter, making cleaning a doddle! Just wash the Splash Shield in hot soapy water or place in a dishwasher between two dinner plates.

Please be advised the boiling plate setting is too hot to cook food directly on it.

## 9. Cooking table

<b>Roast oven</b>	<b>Ideal for</b>
1st runner	Grilling (1st runner only suitable for cold plain shelf and roasting tin).
2nd runner	Grilling, browning, gratin.
3rd runner	Small pastries, scones, bread rolls, Yorkshire puddings.
4th runner	Roast meat and poultry.
Oven grid shelf on base of oven	Bread loaves, pastries, roast vegetables.
Floor grid on base of oven	Quiches, pies, pizza, shallow frying.
<b>Top oven 'e' setting</b>	<b>reverts upper oven to baking temperature</b>
2nd runner	Whisked sponges.
3rd runner	Baked fish, soufflés, shepherd and cottage pie, lasagne, some biscuits and small cakes.
4th runner	Biscuits, small cakes, muffins, shortbread.
Oven grid shelf on base of oven	Victoria sandwich, fruitcake, traybakes and cheesecake.
<b>Lower Baking Oven</b>	
1st runner	Whisked sponges, some biscuits and small cakes.
2nd runner	Baked fish, soufflés, shepherd and cottage pie, lasagne, Victoria sandwich, fruitcake, traybakes and cheesecake.
3rd runner	Suitable for batch baking, additional trays of biscuits and cakes but always swap trays around before end of cooking to even browning.
<b>Lower Simmer Oven or 'e' setting</b>	<p>For casseroles, stock, milk puddings and similar dishes bring to heat on the hotplate or induction hob, then transfer to the simmering oven (one exception is meringues).</p> <p>Meringues can be dried out on baking trays placed on position 2.</p> <p>Rich fruit cakes can also be cooked here for a long time on position 2.</p>

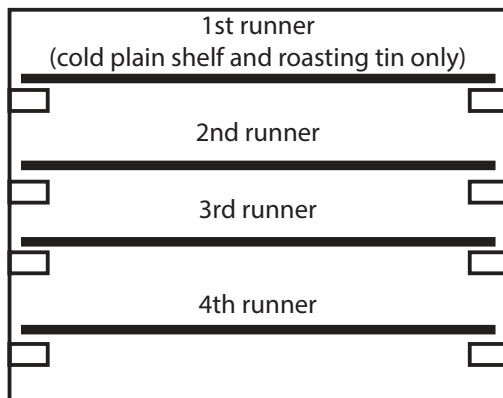

Upper cast roast oven

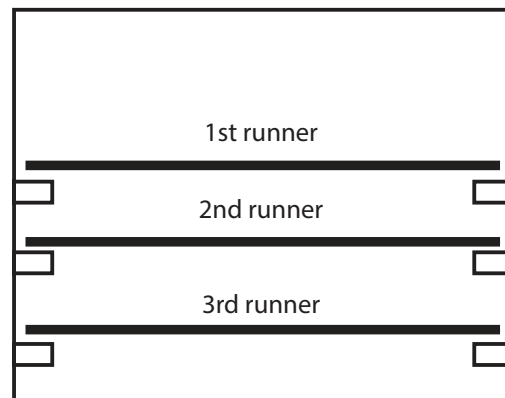

Lower bake/simmer oven

# 10. Oven shelves

## Fitting the shelves for cast iron roast oven

Fig. 10.1

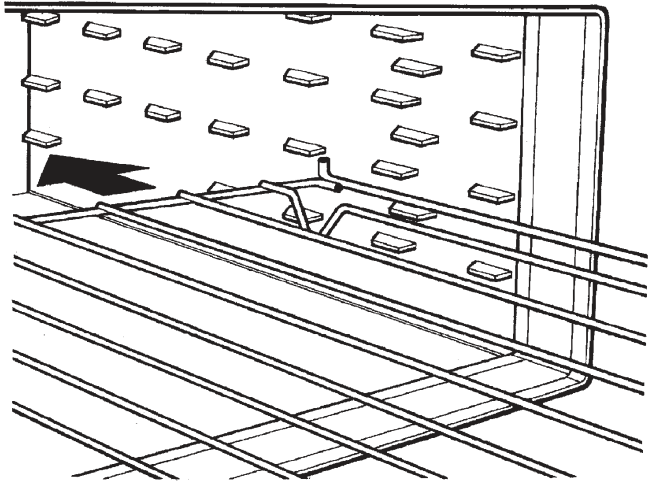

DESN 512403

Fig. 10.2

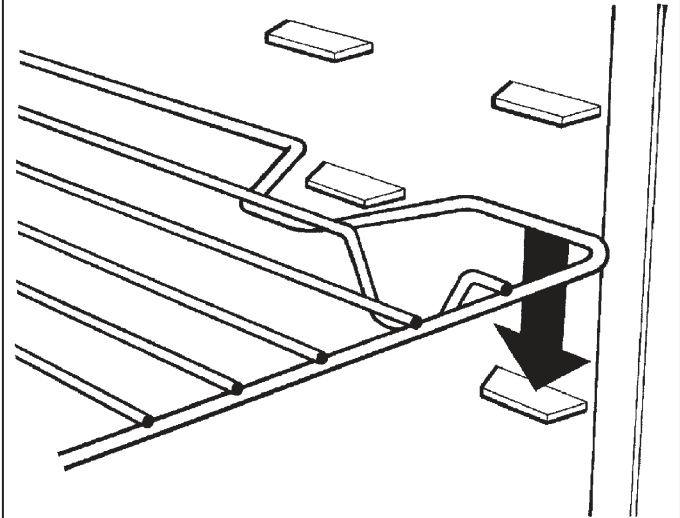

DESN 512404

## Removing the shelves for cast iron, roast oven

Fig. 10.3

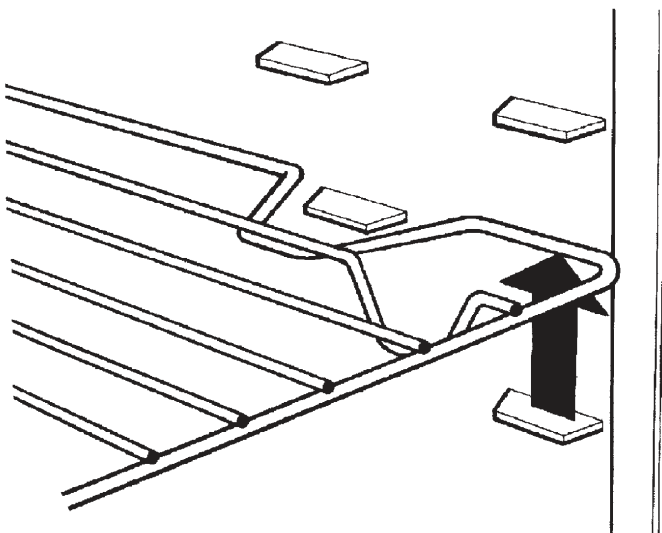

DESN 512405

Fig. 10.4

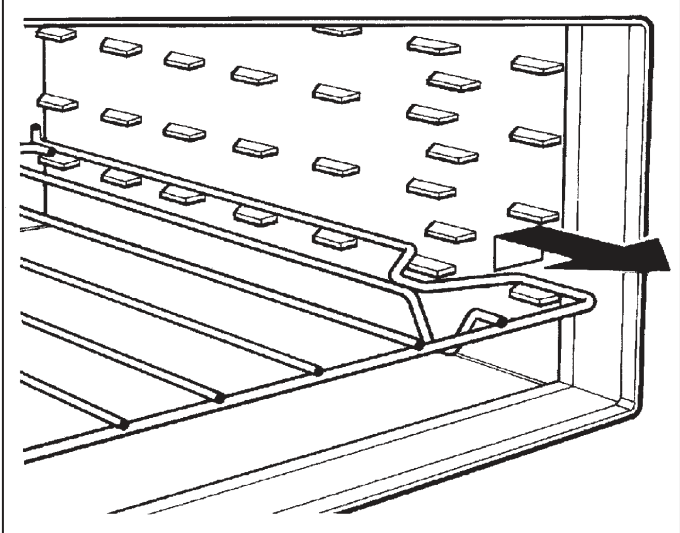

DESN 512406

## Shelves for bake/simmer, warming and grill

**Fitting and removal of shelves** *These shelves are designed to slide out Note: Shelf slides out to stop position.*

Fig. 10.5

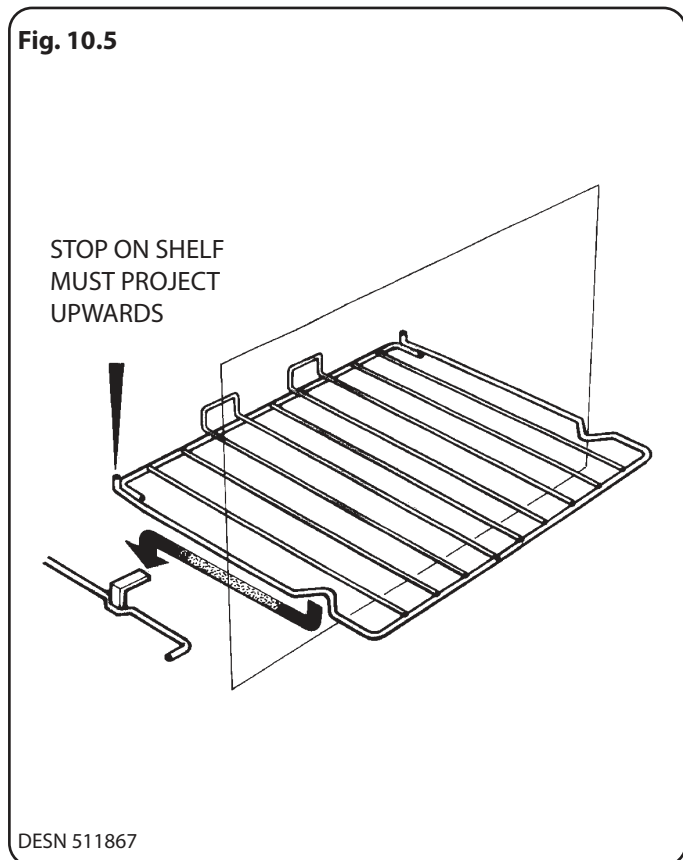
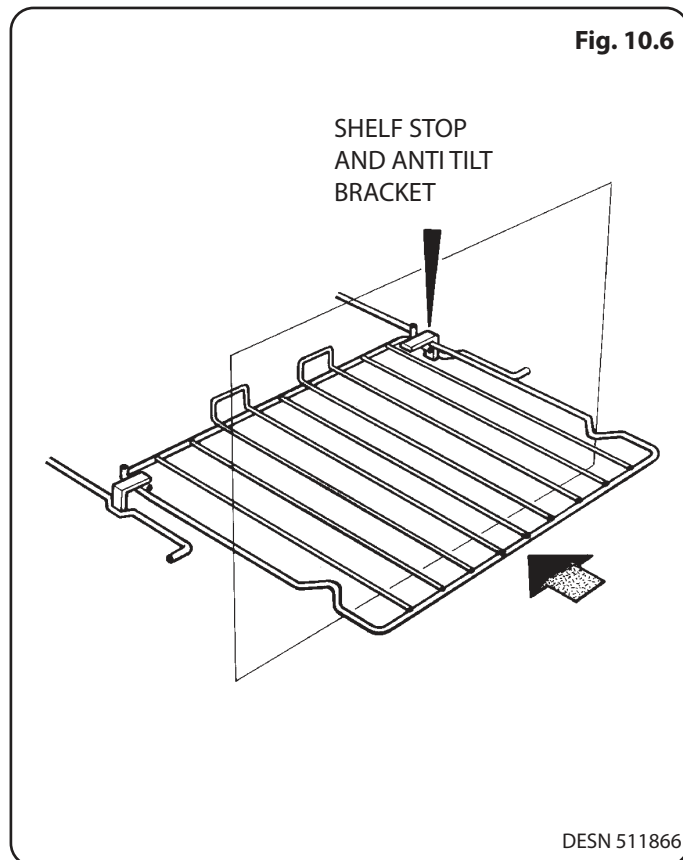

Fig. 10.6



## Hotplate & Oven Seasoning

The hotplates and ovens within your AGA Rangemaster appliance are made from cast iron and are very durable; however, cast iron will naturally oxidise in most environments.

All surfaces of the ovens and hotplate(s) must be fully dried and evenly seasoned.

All ovens and hotplates should be regularly seasoned with a suitable cooking oil, (see note on smoke points). This is done by either spraying or rubbing oil onto all exposed uncoated cast iron surfaces in the ovens and on the hotplates, and then heating them to season the oil into the castings surface. Over time, this will create a protective layer that will prevent moisture from causing oxidation.

This process should be repeated once a week for 6 weeks when your appliance is first received.

If at any point your appliance is not due to be used for an extended period, the seasoning process should be followed.

### Recommended oils for seasoning cast iron.

Most cooking oils can be used for seasoning cast iron. Consideration should be taken to the smoke point temperature. The adjacent table list suitable oils in order of their smoke point.

The values in this table represent the typical smoke point for commercially available edible oils. Smoke points may vary within a source oil due to such factors as processing techniques and / or seasonal variations.

TYPE of OIL	Smoke Point °C
Avocado Oil (Virgin)	271.1
Safflower Oil	260.0
Rice Bran Oil	232.2
Soybean Oil	232.2
Peanut Oil	232.2
Corn Oil	232.2
Sunflower Oil	226.7
Canola Oil	218.3
Grapeseed Oil	215.6
Vegetable Oil	204.4
Extra-Virgin Olive Oil	190.6
Vegetable Shortening	182.2
Coconut Oil	176.7

## 11. AGA accessories

Fig. 11.1



Fig. 11.2



Fig. 11.3



Fig. 11.4

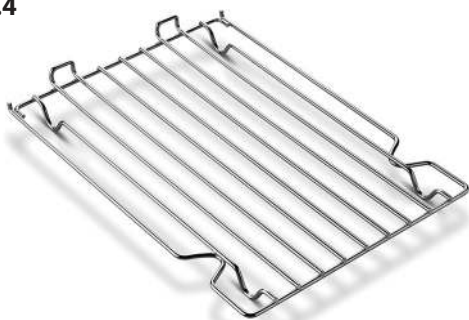
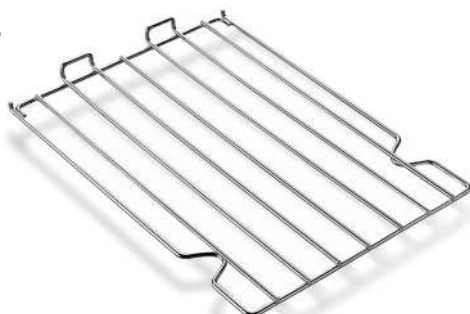

Fig. 11.5



### AGA accessories in your R3

To get the very best performance from your range we recommend AGA saucepans with the thick tri-core bases and stacking lids so that the maximum use of oven space is made and an AGA kettle for boiling water. AGA Accessories can be viewed at your AGA Specialist or online at [www.agacookshop.co.uk](http://www.agacookshop.co.uk)

#### Getting to know your AGA

If you have not already seen a demonstration, ask your AGA Specialist for details. A demonstration will show you how to get the best from your new AGA and will give you hints and tips. You will also see a selection of AGA utensils and accessories being used.

### Accessories in your AGA R3

#### 1 x large size roasting tin/grill pan and rack (Fig. 11.1)

This tin can be used as a grill pan for the infrared grill.

This is designed to slide onto the oven runners without the need for it to sit on an oven grid shelf. The roasting tin can be used with the grill rack, in its high position, for grilling at the top of the roasting oven. It can be used for roasting meat, or poultry with or without the grill rack.

#### 1 x half size roasting tin/grill pan and rack (Fig. 11.2)

This tin can be used as a grill pan for the infrared grill.

This tin can be slid onto the oven runners width-ways or can sit on an oven grid shelf. The half size roasting tin can be used with the grill rack, in its high position, for grilling at the top of the roasting oven.

#### 1x Floor Grid (Fig. 11.3)

This grid is used on the floor of the upper oven, in particular the roasting and simmering ovens to protect food needing over 30 minutes cooking from the intensity of the heat from the base element.

#### 1x Oven Grid Shelf for the upper oven (Fig. 11.4)

These are for inserting in the Roast oven to provide a surface for dishes and tins which do not fit direct onto the oven runners.

#### 3x Oven Shelves (Fig. 11.5)

These are for the Bake / Simmer, warming oven and grill cavity.

### 1x Cold Plain Shelf (Fig. 11.6)

For use in cast iron oven only.

This has two uses; one as a large baking sheet, in the roast oven only, for scones, biscuits and pastry items, the other as a heat deflector to cut off the top heat if food is over-browning before it is cooked through.

**⚠ DO NOT STORE IN THE OVENS WHEN NOT IN USE.**

### 1x Toaster (Fig. 11.7)

This is for toasting bread on the boiling plate. AGA toast is renowned for its excellence, crisp on the outside and soft in the centre. Take thick slices of bread and place in the AGA toaster - if the bread is very moist or very fresh, heat the toaster beforehand to prevent sticking - lift the boiling plate insulated cover and place the toaster direct onto the plate with the handle at an angle from the handle of the cover.

Close the cover and wait for the bread to toast one side - this will take 1-2 minutes dependent upon the variety of bread - open the cover and turn the toaster over and repeat the process to toast the other side. The toaster can also be used for heating pitta bread, toasting teacakes and as a cake cooling rack.

### 1x Wire Brush (Fig. 11.8)









This is for cleaning the raw cast iron surfaces, keeping them clear of crumbs and burnt on debris - which would otherwise affect the boiling performance of pans and the kettle. Use on the hotplates and the ovens. Take care not to touch the enamel surfaces as the wire brush will scratch the finish.



**WARNING:**

Accessible parts may become hot during use. To avoid burns and scalds children should be kept away.

## 12. Cleaning & Caring

-  **REMEMBER: be careful of the hot appliance.**
-  **For most cleaning it is best when the appliance is turned off.**
-  **DO NOT use a steam cleaner to clean this cooker.**
-  **DO NOT use abrasive pads, caustic cleaners, oven cleaners or metal scrapers to clean the surfaces of the enamel.**
-  **IMPORTANT: AGA recommend Vitreous Enamel Association approved cleaners for cleaning the vitreous enamelled surfaces of this product.**
-  **When cleaning use as little water as possible.**
-  **DO NOT immerse the doors in water as they are packed with insulating material, which will be damaged by excessive moisture.**
-  **DO NOT put oven doors or resting plates in a dishwasher.**

All that is usually needed to keep the vitreous enamelled surfaces of your cooker bright and clean is a daily rub over with a damp, soapy cloth followed immediately with a clean, dry cloth to avoid streaks.

**Roast Ovens and Hotplates** - are made from cast iron and keep themselves clean. They are very durable, but will rust if surface moisture is left on them. Remember to always switch the ovens on, to dry them out after cleaning.

Heating up the ovens periodically will help burn off any cooking deposits to aid cleaning within the ovens.

To season the ovens, a light vegetable spray oil (corn oil is best) is recommended. Any stubborn stains can be removed with the wire brush supplied.

**Enamelled cast iron** The easiest way to clean the AGA top plate and front plate is to mop up spills as they happen. VEA approved AGA Enamel Cleaner can be purchased from [www.agacookshop.co.uk](http://www.agacookshop.co.uk).

Baked on food is more difficult to clean but can usually be removed with proprietary vitreous enamel cleaners or mild cream cleaners using a cloth, or if necessary, a nylon scouring pad and can be purchased from [www.agacookshop.co.uk](http://www.agacookshop.co.uk).

If milk or fruit juice, or anything containing acid is spilt on the enamel, wipe off immediately.

Clean off any condensation streaks on the front plate around the oven doors or vitreous enamel maybe permanently discoloured.

Remember the top plate and the polished covers will scratch if pans or utensils are dragged across them.

### Enamelled Bake/Simmer, Warming Oven and Grill

Wipe the panel(s) with a lint free cloth and hot soapy water. The panel(s) should then be dried.

-  **DO NOT use steel wool, oven cleaning pads, or any other materials that will scratch the surface.**

**The top of the insulated cover (lid)** This is chrome or stainless steel and can be kept clean by wiping over with a damp cloth and polished up - the AGA E-cloths are excellent for this purpose as they are lint-free and eco-friendly. AGA stainless steel and chrome cleaner are recommended to keep the insulated cover clean and shining. These can be purchased from your local AGA Specialist.

**Lining of the insulated cover (lid interior)** The use of an AGA splash shield is recommended to keep the lining free of fat splashes, (obtainable from your AGA Specialist or on-line at [www.agacookshop.co.uk](http://www.agacookshop.co.uk)).

If the lining is marked it is best cleaned when the hotplate is cold. It can be cleaned with hot soapy water and/or a cream cleanser. If badly marked then a soap impregnated pad can be used - this should be used in a circular motion.

The first few times a soap impregnated pad is used you will see the circular marks, these will become reduced and the surface of the lining becomes shinier each time when used. Do not use excessive water and make sure the lining is dry before closing the cover.

**Oven door linings** The linings can be cleaned with hot soapy water, a cream cleanser or soap impregnated pad. To deep clean the lining place a towel on the work surface and carefully lift off the oven door (doors are heavy) and place it enamel side down on the towel padding. Clean with a soap impregnated pad to remove stubborn marks. Dry off before replacing on their hinges.

**Enamelled roasting tins** Those supplied with the appliance should be cleaned in hot soapy water, soaking if necessary. A nylon scouring pad can also be used. They may also be cleaned in the dishwasher, but with constant use, the enamelled finish will become dull in appearance.

-  **DO NOT USE HOB BRITE ON ENAMELLED SURFACES.**

## 13. Maintenance

---

- Your Aga does not need to be regularly serviced.
- In the event of requiring maintenance, please call AGA Service or your authorised distributor.
- Your appliance **MUST** only be maintained and installed by a qualified engineer, AGA engineer or an authorised distributor.
- **DO NOT** alter or modify the appliance.

### **Spare Parts**

To maintain optimum and safe performance, we recommend that only genuine AGA spare parts are used. These are available from most major spares stockists, including ourselves.

## 14. Installation instructions

# WARNING!

Please read the Warning, Cautionary notes at the start of this section. If the information contained within these instructions is not followed, property damage or personal injury may occur.

**DO NOT** store or use gasoline or other flammable vapors and liquids in the vicinity of this or any other appliance.

Installation and service must be performed by a qualified installer or service agency.

**WARNING!** This appliance must be installed with an appropriate device that will allow permanent disconnection of the Live and Neutral conductors. During Installation or disconnection prior to any electrical work, the appliance must be permanently disconnected from the Supply (Live) and Neutral Conductors.

**CAUTION: THIS UNIT IS HEAVY, PROPER EQUIPMENT AND ADEQUATE MANPOWER MUST BE USED IN MOVING THE RANGE TO AVOID DAMAGE TO THE UNIT OR THE FLOOR.**

**REMEMBER**, when replacing a part on this appliance, use only spare parts that you can be assured conform to the safety and performance specification that we require.

**DO NOT** use reconditioned or copy parts that have not been clearly authorised by AGA.

**PLEASE READ THESE INSTRUCTIONS BEFORE USING THIS APPLIANCE  
AND KEEP IN A SAFE PLACE FOR FUTURE REFERENCE.**

# 15. Installation introduction

---

## Consumer protection

As a responsible manufacturer, we take care to make sure that our products are designed and constructed to meet the required safety standards when properly installed and used.

### **WARNING - ELECTRIC SHOCK HAZARD**

It is the customer's responsibility to contact a qualified electrical installer to make sure the electrical installation is adequate and in conformance with the regulations.

Take special care when cutting holes in walls or floor. Electrical wires may be behind the wall or floor covering and could cause an electrical shock if you touch them.

Locate any electrical circuits that could be affected by the installation of this product and disconnect power circuit.

### **WARNING: THIS APPLIANCE MUST BE EARTHED.**

**DO NOT** use an extension lead with this appliance.

The appliance is designed for the voltage stated on the data plate.

Recommended but not mandatory to fit an individual Residual Current Device (RCD) to the cooker supply circuit.

Hand this Manual to the User for retention and instruct in the safe operation of the appliance.

## 16. Product Dimensions R3 100-4h, Twin Dome

Fig. 16.1

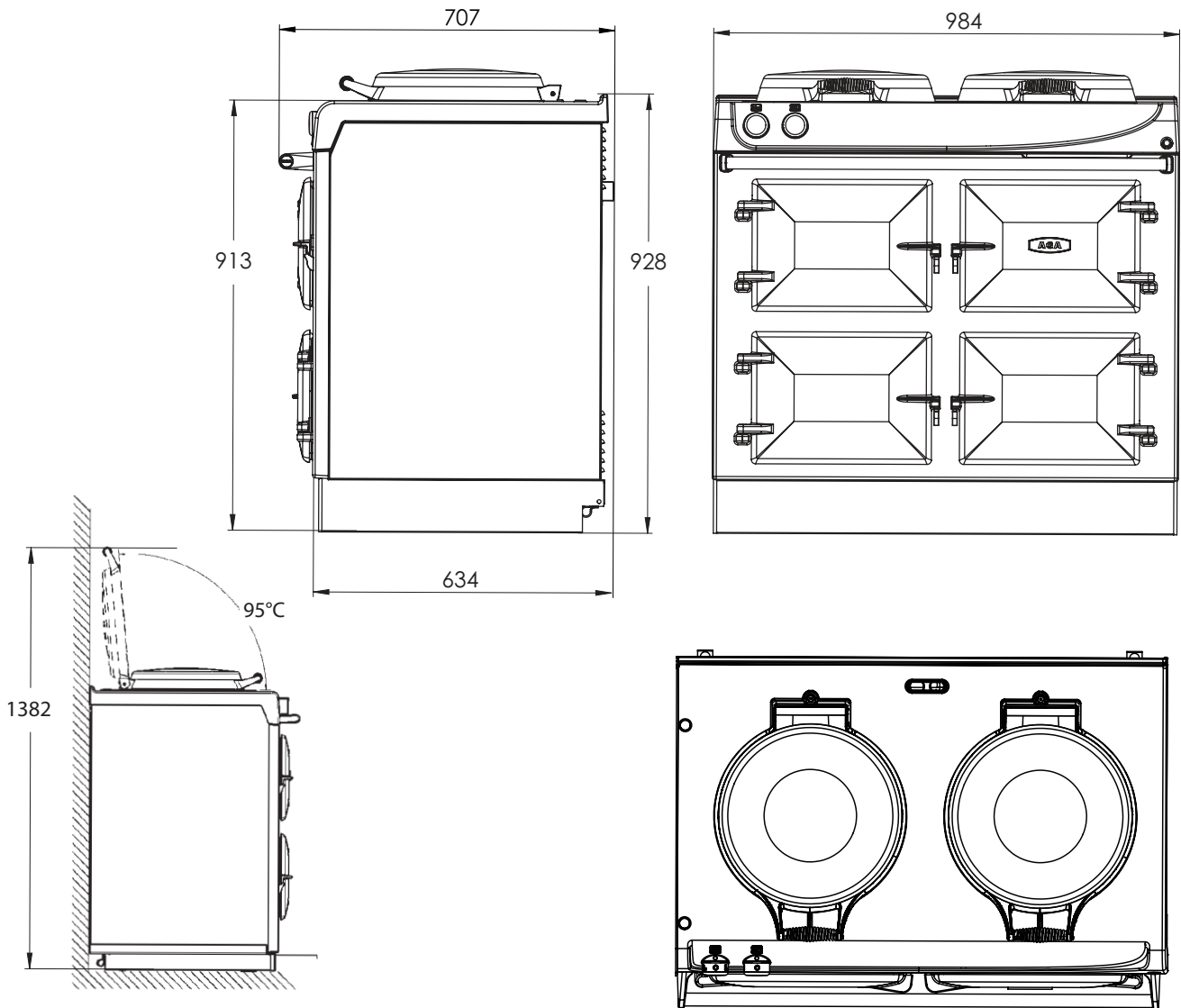

**NOTE:** When surveying for a appliance installation the actual clearance required for the 'body' of the appliance should be increased overall by 10 mm beyond the figures quote above. This allows safe margin to take into account the natural dimensional variations found in major castings in particular the width across an appliance recess could be critical.

### Appliance weights (Excludes packaging)

Model: R3 100/4h  
Weight: 310 kg

Fig. 16.1

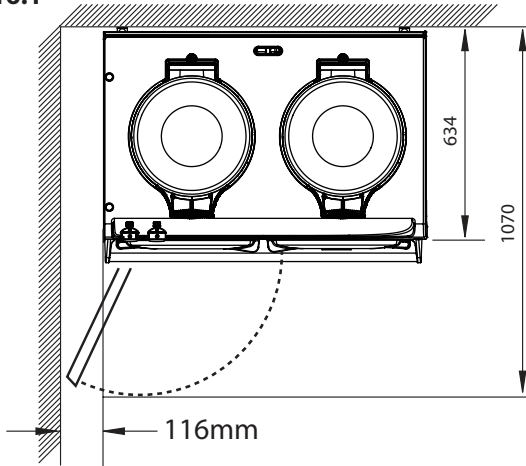
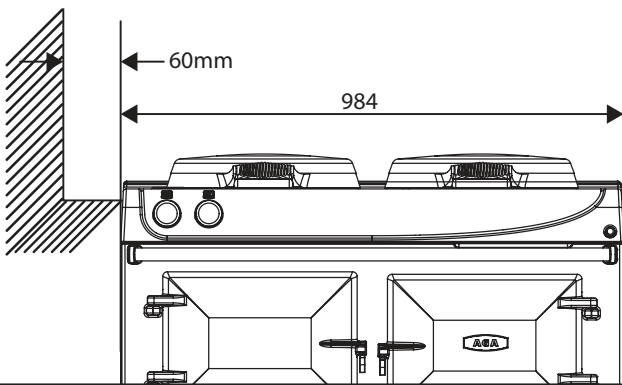

Fig. 16.2



### Side and Overhead Clearances

If you are installing the appliance in a new kitchen or have the opportunity to set the width between kitchen units, it is advisable to include an additional small gap each side of 3mm to assist with installation and prevent damage when moving the product.

A 6mm additional width clearance should also be provided if the appliance is to go into a brick recess, to allow for the wall being out of square.

Where installed against a side wall protruding in the front of the appliance a 116mm clearance is required on the left or right hand side for the oven door access (**Fig. 16.1**).

Any side wall above the appliance on either side shall not be less than 60mm horizontally from the appliance (**Fig. 16.2**).

Surfaces over the top of the appliance must not be closer than 650mm i.e. cabinets or cookerhoods.

The rear gap at the rear of the appliance **MUST NOT** be blocked off or obstructed.

### Appliance Base or Hearth

**⚠** If the appliance is placed on a base, measures have to be taken to prevent appliance from slipping from the base.

It is essential that the base or hearth on which the appliance stands should be level and be capable of supporting the total weight of the appliance.

The front plinth cover is removable and must not be obstructed by flooring or tiles. If necessary the appliance must be raised by the thickness of the tiles to ensure the plinth can be removed, and the appliance can be rolled out for service.

### Tiling

When the appliance is to stand in a recess or against a wall which is to be tiled, under no circumstances should the tiles overlap the appliance top plate, access to remove the top plate must be allowed for servicing at a later date.

### Rear Clearances (including Combustible Rear Walls)

**SPECIAL NOTE:** Ensure that unprotected electric cabling or plastic services do not pass within or on the outside of the wall behind or directly above the appliance. This type of material can age prematurely when exposed to continuous higher temperature.

Please note **every** appliance is fitted with 25 mm spacer brackets.

This allows the appliance to be fitted where the rear wall is constructed of combustible materials, such as all-timber or stud wall partitions and batoned plasterboard.

The air gap must be left open and not blocked off across the top edge (Fig. 16.3) for example tiled over

**IMPORTANT! The air gap at the rear of the appliance must be maintained to provide ventilation for the appliance.**

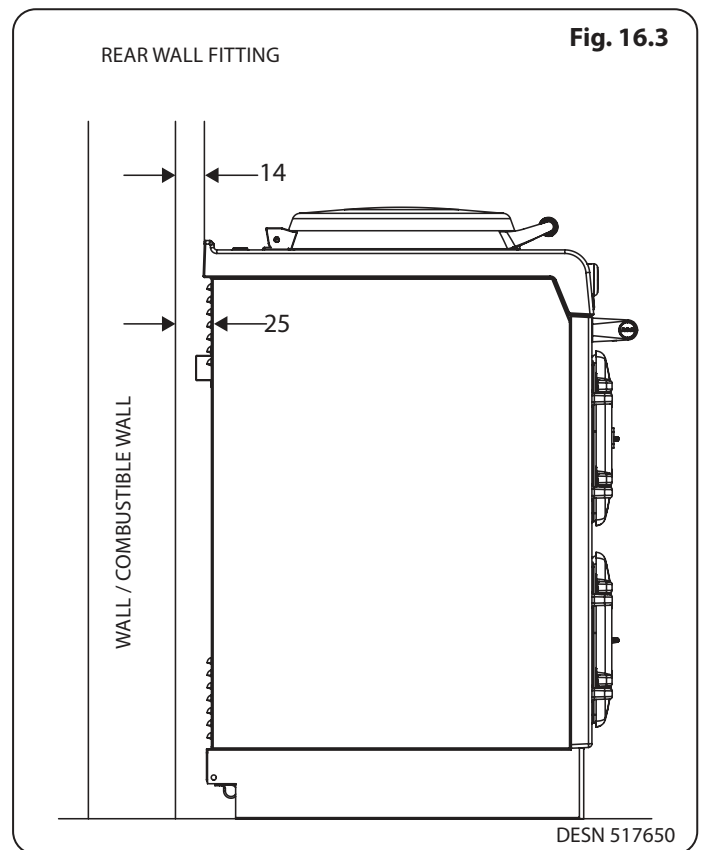

# 17. Electrical connection

- ⚠ WARNING: This appliance must be earthed.**
- ⚠ This appliance is designed for the voltage stated on the rating plate, which is situated behind the plinth cover.**
- ⚠ If the supply cord is damaged, it must be replaced by the manufacturer, its service agent or similarly qualified person to avoid a hazard.**

## For the cooker

Two separate phase 13 AMP 230V ~ 50 Hz fused electrical supply are required adjacent to the appliance. External wiring to the unit must be installed using the mains cable provided, in accordance with the current wiring regulations and any local regulations which apply. If the cable is shortened, new ferrules must be fitted to the stripped conductors.

The method of connection to the mains electricity supply must facilitate complete electrical isolation of the appliance, by a multi-pole switch, having a contact separation of at least 3 mm on all poles.

The isolator should not be positioned immediately above the cooker, but must be fitted within 2 metres of the appliance.

The isolator may separate from the connection point.

The mains connection point must be accessible within the areas shown in **Fig. 17.1** and **Fig. 17.2** for cable routing options.

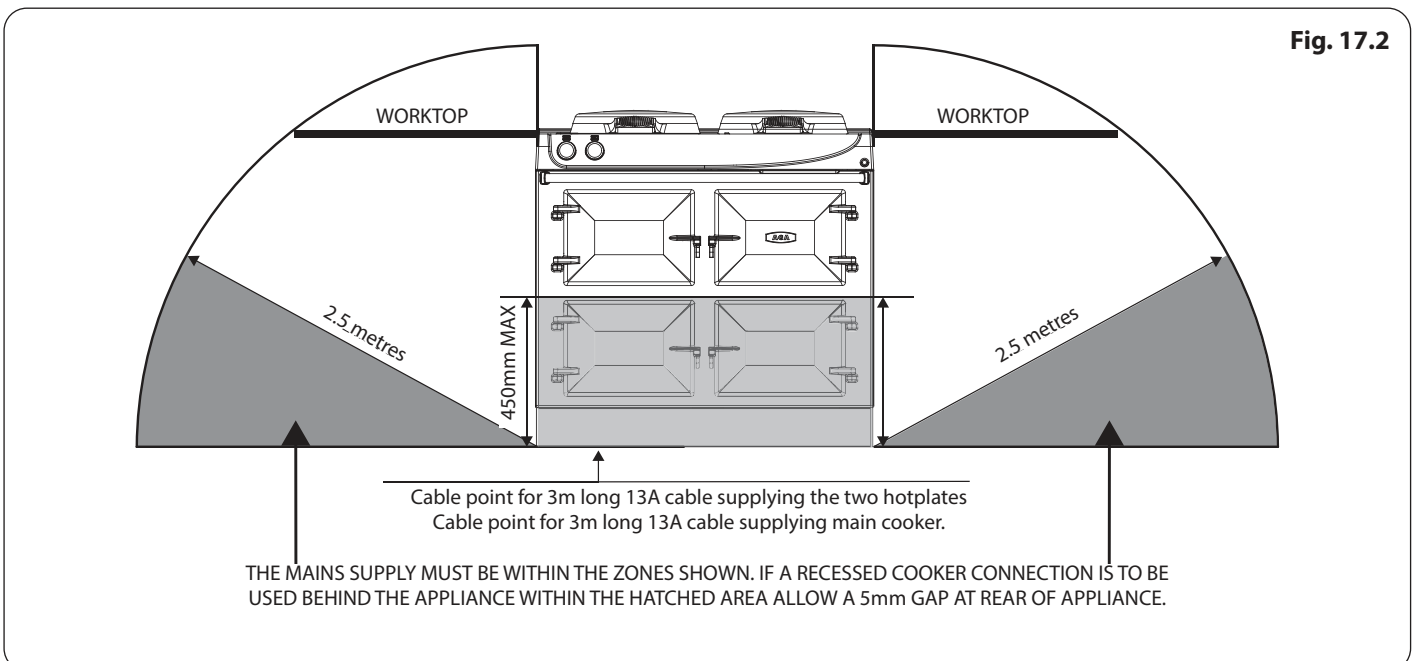
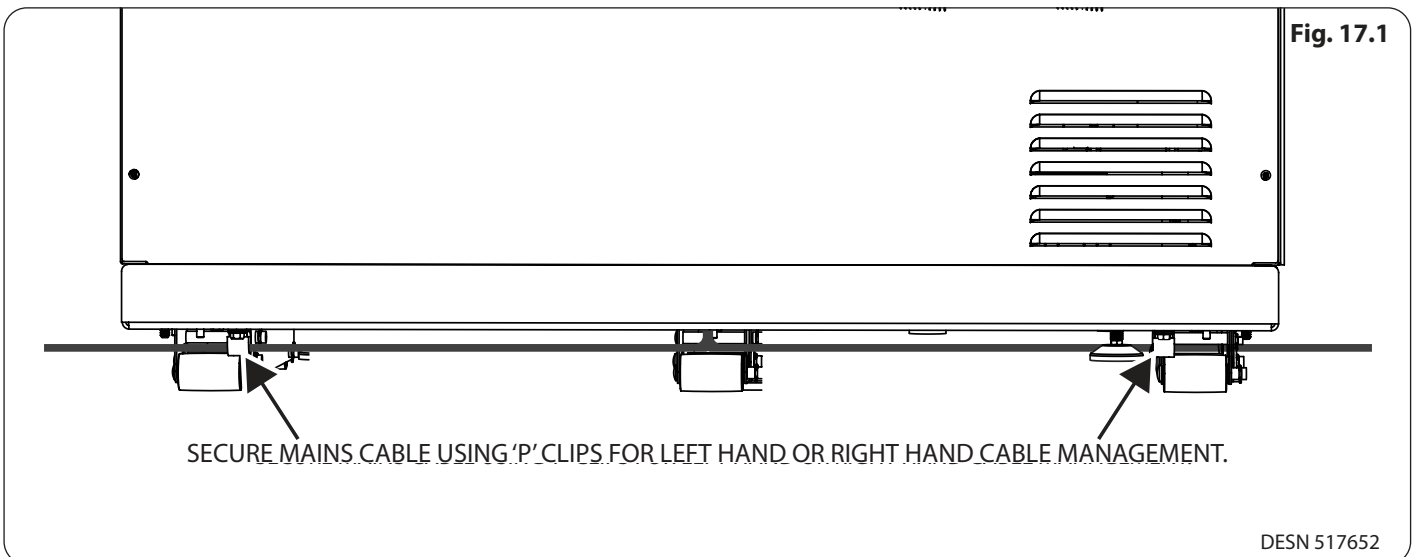

# 18. Installation and Levelling

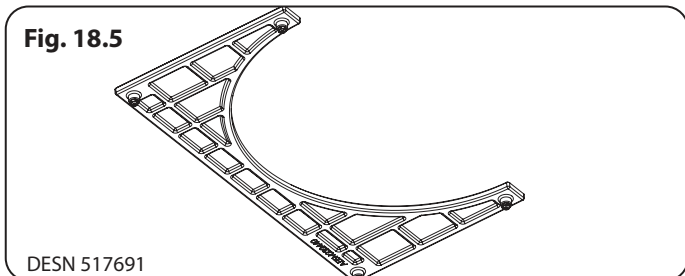
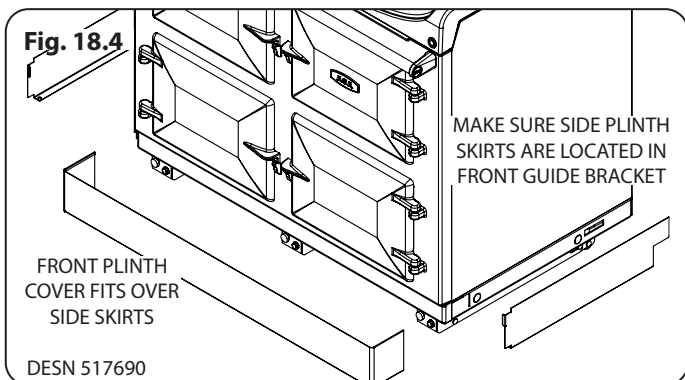
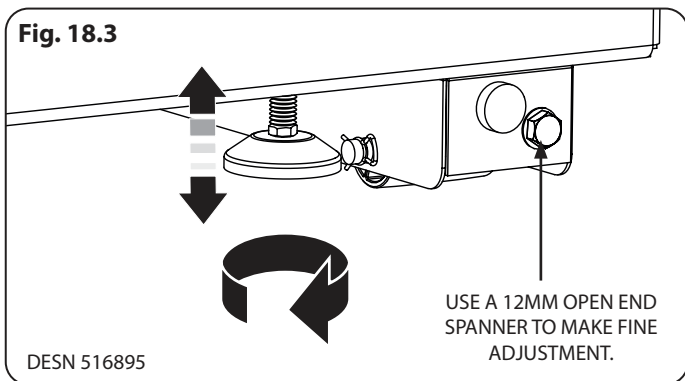
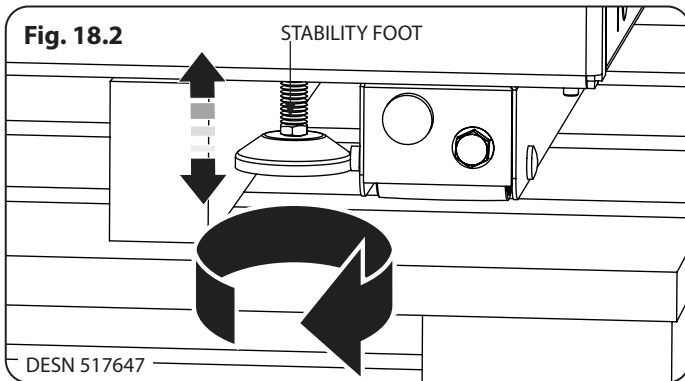
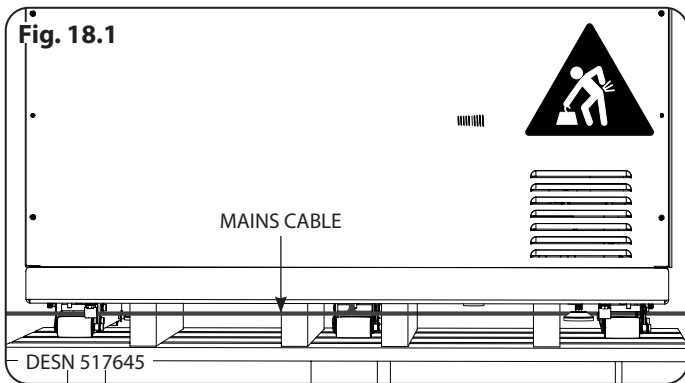

1. **NOTE:** Care must be taken not to trap mains cables (**Fig. 18.1**).
2. When removing appliance from the pallet, the front stability feet can be raised with a spanner to allow appliance to be slid from transit pallet (**Fig. 18.2**).
3. Slide cooker off transit pallet.
4. Appliance can now be pushed back on its wheels into desired position. **NOTE:** Care must be taken not to trap mains cable.
5. **Levelling of appliance** - Use 12mm socket to adjust wheel mechanism for FINE adjustment on both sides at rear of the appliance (**Fig. 18.3**).
6. Using a 13mm open end spanner, feet can be adjusted at front to make **FINE** adjustments to the front of the appliance and to provide a brake for the wheels (**Fig. 18.3**).
7. Turning the bolt clockwise will lower the wheel thus increasing height of the cooker (**Fig. 18.3**).
8. Anti-clockwise lifts the wheels and lowers the cooker (**Fig. 18.3**).
9. Fit the magnetic plinth (**Fig. 18.4**) and sides.
10. **Resting Plate Adjustment** - Resting plates have adjuster screw feet for setting of height and to improve stability (**Fig. 18.5**).

## 19. Control knob and handrail connection

Fig. 19.1

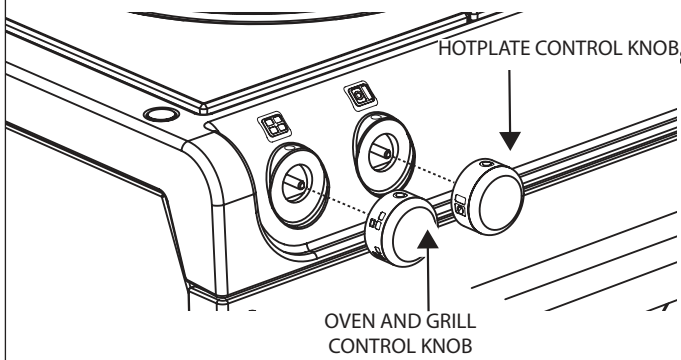

DESN 517654

### Control Knob Location

Ensure control knobs are located onto spindles correctly, as shown in (Fig. 19.1).

### Handrail Location

Locate handrail onto spindle, lock into position with grub screws (located on the inside of the bracket) (Fig. 19.2).

Fig. 19.2

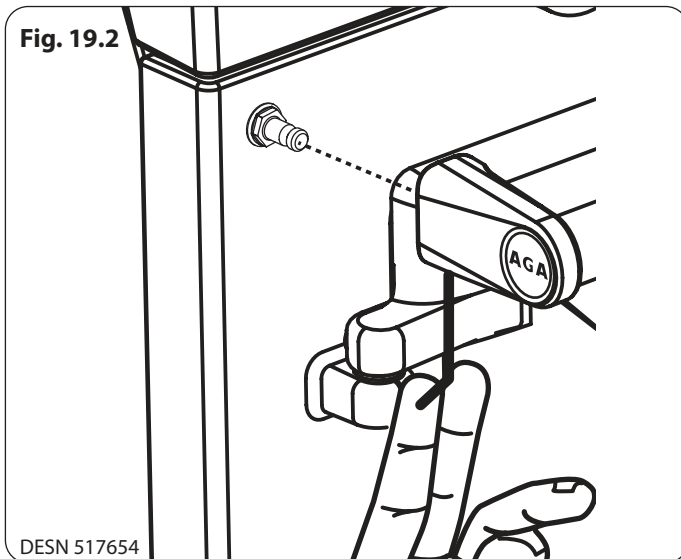

DESN 517654

# 20. Circuit diagrams

Colour	Code
Brown	<b>BRN</b>
Blue	<b>B</b>
Black	<b>BLK</b>
Green	<b>GRN</b>
Yellow	<b>Y</b>
Red	<b>R</b>
Violet	<b>V</b>
Grey	<b>GRY</b>
White	<b>W</b>
Orange	<b>O</b>

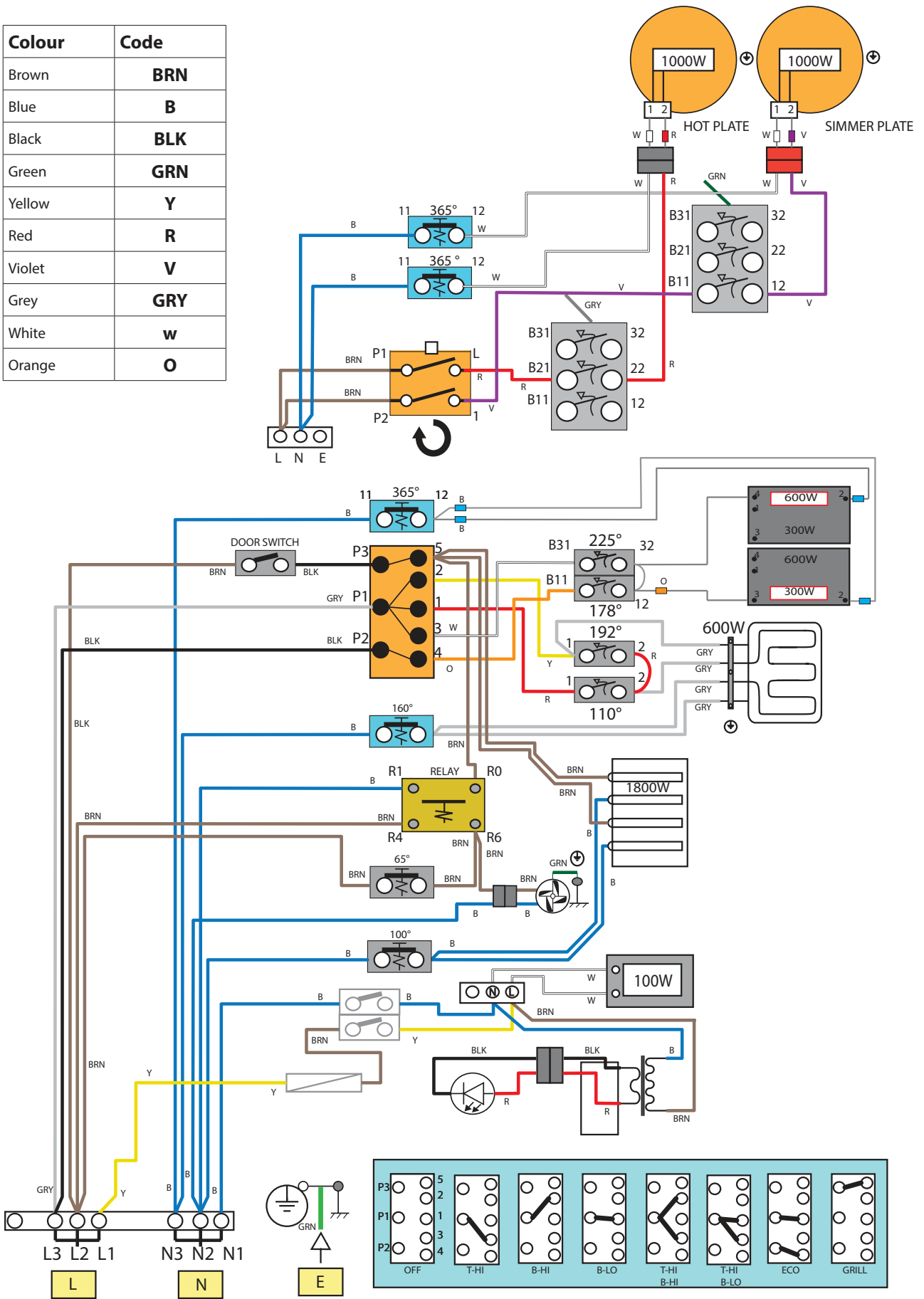



## **AGA CLOUD, THE FIRST AGA RECIPE APP**

Download AGA Cloud to view a host of delicious step-by-step recipes tailored to your AGA appliance.

*Available only in the United Kingdom and Ireland.*



With AGA Rangemaster's policy of continuous product improvement, the Company reserves the right to change specifications and make modifications to the appliances described and illustrated at any time.



Manufactured By  
AGA Rangemaster  
Station Road  
Ketley Telford  
Shropshire TF1 5AQ  
England

[www.agaliving.com](http://www.agaliving.com)  
[www.agacookshop.co.uk](http://www.agacookshop.co.uk)

