



User Manual



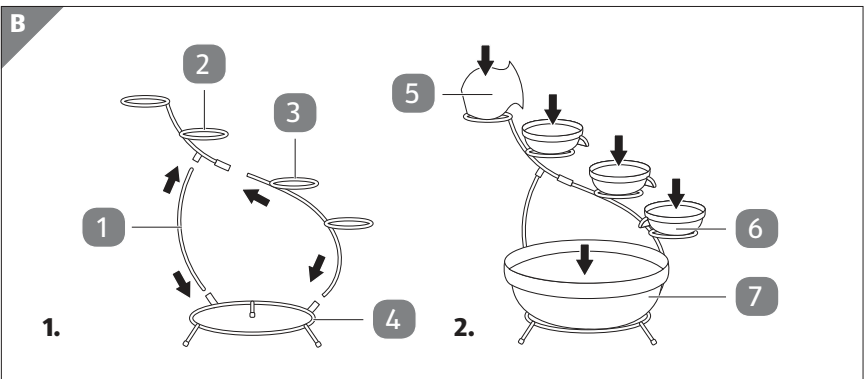
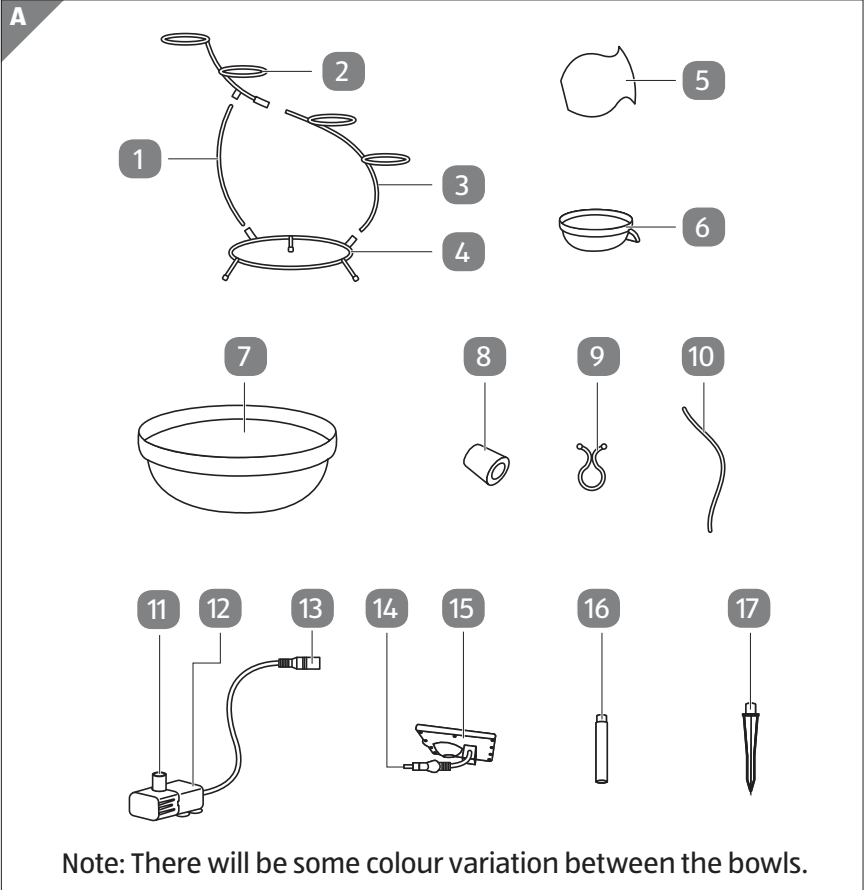
SOLAR WATER FEATURE

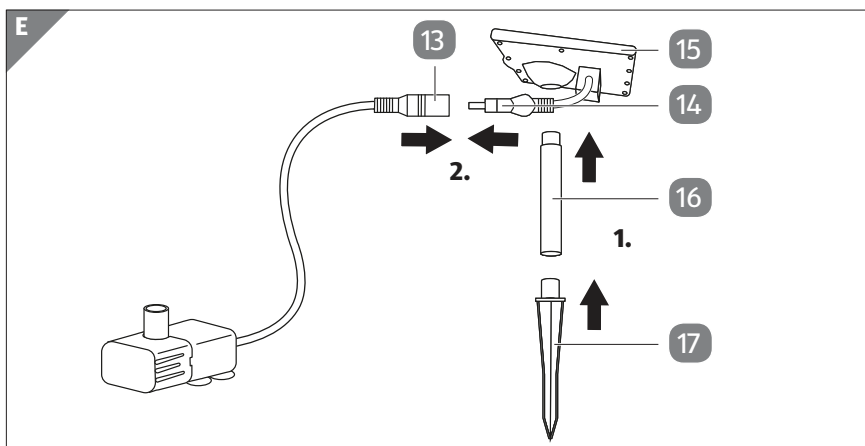
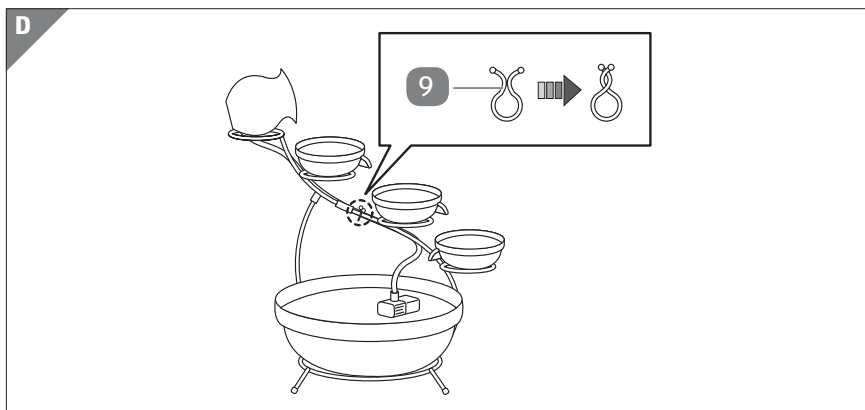
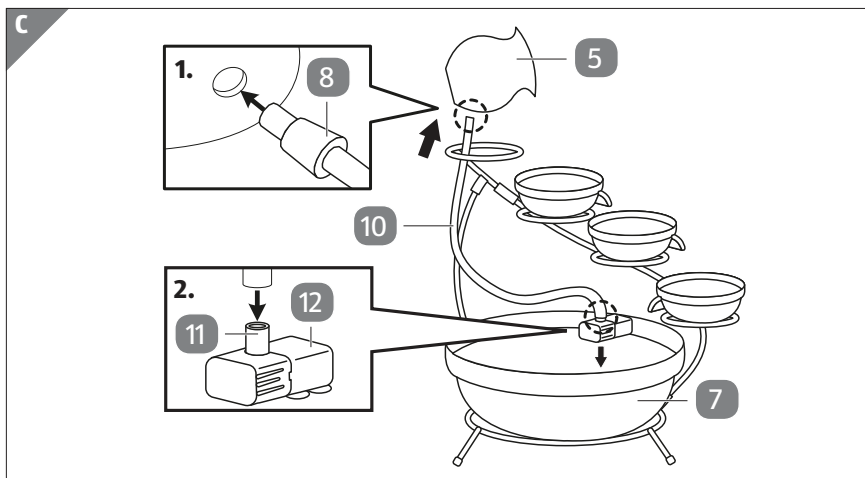


Table of contents

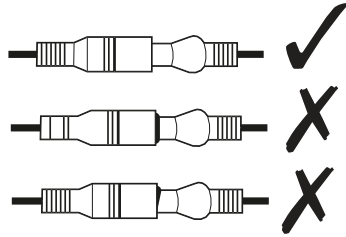
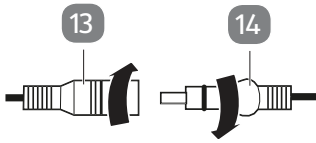
Scope of delivery	3
Components	6
General information	7
Reading and storing the user manual	7
Proper use.....	7
Explanation of symbols	7
Safety	8
Signal symbol/word definitions.....	8
General safety instructions	8
First use	10
Checking the product and scope of delivery	10
Basic cleaning.....	11
Using the product	11
Optimal use of the solar panel	12
Troubleshooting	12
Cleaning	12
Cleaning the pump.....	13
Storage	13
Technical data	13
Declaration of conformity	14
Disposal	14
Disposing of the packaging	14
Disposing of the product	14

Scope of delivery

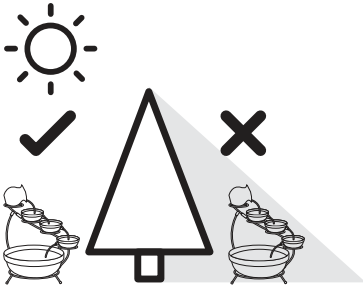




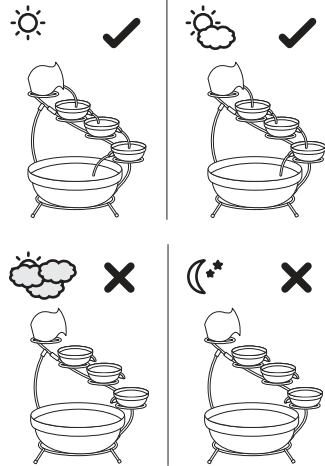
F



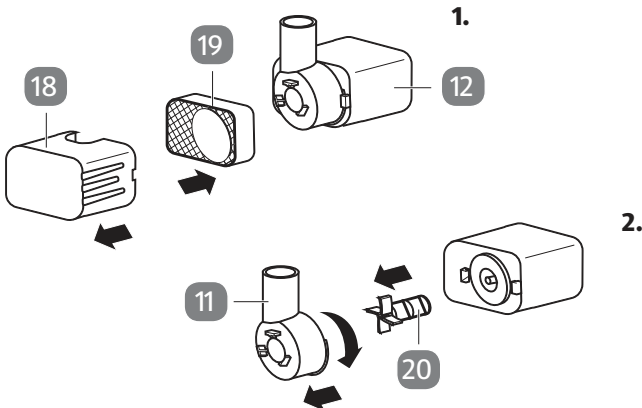
G



H



I



Components

- 1 Stand support
- 2 Upper stand
- 3 Lower stand
- 4 Base stand
- 5 Jug
- 6 Small bowl, 3×
- 7 Large bowl
- 8 Bung
- 9 Clip, 3×
- 10 Hose
- 11 Water outlet
- 12 Pump
- 13 Power connector
- 14 Power plug
- 15 Solar panel
- 16 Pole
- 17 Ground stake
- 18 Filter housing
- 19 Filter
- 20 Impeller

General information

Reading and storing the user manual



This user manual accompanies this solar water feature (hereafter referred to as the “product”), and contains important information on setup and handling.

Before using the product, read the user manual carefully. This particularly applies to the safety instructions. Failure to do so may result in personal injury or damage to the product.

The user manual is based on the standards and rules in force in the United Kingdom and European Union (Ireland). When abroad, you must also observe country-specific guidelines and laws.

Store the user manual for further use. Make sure to include this user manual when passing the product on to third parties.

Contact After Sales Support for additional copies of the user manual.

Proper use

The product is exclusively designed for garden decoration. It is only intended for private use and not suitable for commercial purposes. The product is not a children’s toy.

Only use the product as described in this user manual. Any other use is considered improper and may result in damage to property or persons.

The manufacturer or vendor cannot be held liable for damages or injury incurred through improper or incorrect use.

Explanation of symbols

The following symbols are used in this user manual, on the product or on the packaging.



This symbol provides you with useful additional information on handling and use.



Declaration of Conformity (see chapter “Declaration of Conformity”): Products labelled with this symbol meet all applicable provisions of the European Economic Area.

IP68

This symbol identifies products protected from dust ingress and are suitable for continuous immersion in water.



This symbol identifies voltage and the current rating for direct current.



Maximum water depth for the pump



Caution! The product is heavy.

Safety

Signal symbol/word definitions

The following symbols and signal words are used in this user manual.



This signal symbol/word designates a hazard with moderate risk, which may result in death or severe injury if not avoided.



This signal word warns of possible damage to property.

General safety instructions



Risk of injury!

If you do not use the product properly, there is an increased risk of injury.

- This product can be used by children aged from 8 years and above and persons with reduced physical, sensory or mental capabilities or lack of experience and knowledge if they have been given supervision or instruction concerning the use of the product in a safe way and understand the hazards involved. Children shall not play with the product. Cleaning and user maintenance shall not be made by children unless they are older than 8 and supervised.
- Keep children under the age of 8 away from the product and mains cord.

-
- Make sure that children do not play with the plastic wrapping. They may get caught in it when playing and suffocate.
 - Always keep the inside of the power plug and power connector dry. Wipe off any excess water before connecting.
 - Keep the product and power cord away from open flames and hot surfaces.
 - Lay the power cord so that it does not pose a tripping hazard.
 - Do not kink the power cord and do not lay it over sharp edges.

NOTICE!

Risk of damage!

Improper handling of the product may result in damage to the product.

- Place the product on a stable and level surface.
- Place the product in a location away from any other electrical equipment to avoid the risk posed by water splash.
- Only use the product with clear water at temperature below 35 °C.
- Do not pull or push the product for relocation.
- Never place the product on or near hot surfaces (stove tops, etc.) or expose it to high temperatures (heaters etc.).
- Never attempt to clean the solar panel by immersing it in water and do not use a steam cleaner to clean it. Otherwise, you could damage the solar panel.
- Stop using the product if its parts exhibit cracks or breaks or are deformed. Only replace damaged parts with corresponding original spare parts.

First use

Checking the product and scope of delivery

NOTICE!

Risk of damage!

If you are not cautious when opening the packaging with a sharp knife or other pointed object, you may quickly damage the product.

– For this reason, be very careful when opening it.

1. Take the product out of the packaging.
2. Check to make sure that all parts are included (see **Fig. A**).
3. Check whether the product or individual parts are damaged. If this is the case, do not use the product. Contact the manufacturer via the service address indicated on the warranty card.

Basic cleaning

1. Remove the packaging material and all plastic wrappings.
2. Clean all parts of the product before first use as described in the chapter “Cleaning”.

Using the product

1. Insert the base stand **4**, upper stand **2**, lower stand **3** and stand support **1** onto each other (see step 1 in **Fig. B**).
2. Place the jug **5**, small bowls **6** and large bowl **7** on the assembled stand (see step 2 in **Fig. B**).
3. Attach the bung **8** onto the upper end of the hose **10** and then insert the bung and hose into the opening at the bottom of the jug (see step 1 in **Fig. C**).
4. Attach the lower end of the hose to the water outlet **11** of the pump **12** (see step 2 in **Fig. C**).
5. Place the pump at the bottom of the large bowl and secure the pump with its suction feet.
6. Attach the hose to the stand with the clips **9**. Close the clips to secure the fixing (see **Fig. D**).

7. Fill the small bowls and large bowl with clean water. The water in the large bowl must cover the pump.
8. Insert the ground stake **17** onto the pole **16** and the pole onto the bottom of the solar panel **15** (see step 1 in **Fig. E**).
9. Insert the solar panel into the ground as far as the ground stake allows.
If necessary, use a shovel to loosen hard ground before inserting the solar panel. Do not use any force (e.g. hammer blows) to insert the solar panel as this will cause damage.
See chapter “Optimal use of the solar panel” for more details.
10. Insert the power plug **14** into the power connector **13** (see step 2 in **Fig. E**).
Slightly twist the power plug and power connector during insertion to ensure a water-tight connection (see **Fig. F**).
The pump starts working as soon as it receives sufficient solar power.



Water must be regularly topped up in the bowls during use.

Optimal use of the solar panel

- Position the product in such a way that the solar panel **15** can absorb maximum sunlight. A shady position will affect its operating capacity (see **Fig. G**).
- The product is designed primarily to operate in summer months but will also work in spring and autumn provided that there is good sunshine. Performance is directly related to the amount and strength of sunlight received (see **Fig. H**).

Troubleshooting

Some problems may be caused by minor faults that you can fix yourself. To do so, follow the instructions in the following table. If it is still not possible to resolve the problem, contact customer service. Do not repair the product yourself.

Problem	Possible reason and solution
The product does not operate, or the performance drops.	<ul style="list-style-type: none"> – Make sure the solar panel 15 is correctly positioned. – Make sure there is sufficient water in the bowls 6/7. – Make sure the filter 19 of the pump 12 is clean (see chapter “Cleaning the pump”). – Make sure there is no debris in the bowls blocking the pump.

Cleaning

NOTICE!

Risk of short circuit!

Water that has penetrated the housing may cause a short circuit.

- Make sure that no water penetrates the housing of the solar panel.
- Never immerse the solar panel in water.

NOTICE!

Risk of damage!

Improper handling of the product may result in damage.

- Do not use any aggressive cleaners, brushes with metal or nylon bristles, or sharp or metallic cleaning utensils such as knives, hard scrapers and the like. They could damage the surfaces.
1. Disconnect the power plug **14** from the power connector **13** before cleaning.
 2. Regularly change the water in the jug **5** and bowls **6/7**.
 3. Use a damp cloth to wipe off the stand, jug, bowls and solar panel **15**. Then let all parts dry completely.

Cleaning the pump

The components of the pump **12** can be disassembled for regular cleaning to ensure optimum performance.

1. Disconnect the power plug **14** from the power connector **13** before cleaning.
2. Gently pull the filter housing **18** to remove it from the pump. Then remove the filter **19** from the filter housing (see step 1 in **Fig. I**).
3. Slightly rotate the water outlet **11** clockwise and then detach it from the pump. Remove also the impeller **20** from the pump (see step 2 in **Fig. I**).
4. Clean the filter housing, filter, water outlet and impeller under running water. Attach them back to the pump after cleaning.

Storage

All parts must be completely dry before being stored.

- Always store the product in a dry area.
- Protect the product from frost. Store it indoors during cold months.
- Protect the product from direct sunlight.
- Store the product so that it is not accessible to children.

Technical data

Model:	1180130AL / 1180230AL
Dimensions:	Approx. 49 × 41 cm
Rating (solar panel):	6 V, 1.5 W
Rating (pump):	4–12 V $\overline{=}$ 3.5 W Max.
IP code (pump):	68 (protected from dust ingress and suitable for continuous immersion in water)
Max. liquid temperature (pump):	35 °C
Product code:	709757 / 709758

Declaration of conformity



The EU declaration of conformity can be requested from the address specified on the enclosed warranty card.

Disposal

Disposing of the packaging



Sort the packaging before you dispose of it. Dispose of paperboard and cardboard with the recycled paper service and wrappings with the appropriate collection service.

Disposing of the product

(Applicable in the European Union and other European countries with separate collection systems of recyclable materials)



Old appliances may not be disposed of in the household waste! Should the product no longer be capable of being used at some point in time, **dispose of it in accordance with the regulations in force in your city or county.** This ensures that old appliances are recycled in a professional manner and also rules out negative consequences for the environment. For this reason, electrical equipment is marked with the symbol shown here.



Great care has gone into the manufacture of this product and it should therefore provide you with years of good service when used properly. In the event of product failure within its intended use over the course of the first 3 years after date of purchase, we will remedy the problem as quickly as possible once it has been brought to our attention. In the unlikely event of such an occurrence, or if you require any information about the product, please contact us via our helpline support services, details of which are to be found both in this manual and on the product itself.



PRODUCED IN VIETNAM FOR:

ALDI STORES LTD. PO BOX 26, ATHERSTONE
WARWICKSHIRE, CV9 2SH.

ALDI STORES (IRELAND) LTD.
PO BOX 726, NAAS, CO. KILDARE.
Visit us at www.aldi.com

AFTER SALES SUPPORT

709757 / 709758



GB 08448009163

IE 1800932859



customerservices@as647.com

MODEL:

1180130AL / 1180230AL

06/2021

3
YEAR
WARRANTY