

**en** Installation instructions

- de** Installationsanleitung
- fr** Notice d'installation
- it** Istruzioni per l'installazione
- zh** 安装说明
- es** Instrucciones de instalación
- ru** инструкция по установке
- pt** Instruções de instalação
- ko** 설치 매뉴얼



IEC/EN 60947-2,-4-1  
GB/T 14048.2/4  
UL 60947-4-1  
CAN/CSA-C22.2 No. 60947-4-1



At the end of its life, this equipment should be collected separately from any unsorted municipal waste.



**en ATTENTION! HAZARDOUS VOLTAGE!**  
The installation and the operation of this device and any maintenance must be carried out by a qualified person in accordance with specific local standards and safety regulations. Before installing this device, read these operating instructions carefully. Do not touch live parts. To avoid damages to persons and material the devices have to be replaced in case of mechanical and/or electrical damage.

**de ACHTUNG! GEFÄHRLICHE SPANNUNG!**  
Die Installation und die Inbetriebnahme dieses Gerätes sowie jegliche Wartungsarbeiten müssen durch eine qualifizierte Fachkraft durchgeführt werden. Dabei sind lokale Normen und Sicherheitsvorschriften zu beachten. Vor der Installation des Gerätes muss diese Betriebsanleitung aufmerksam gelesen werden. Spannung führende Teile nicht berühren. Um Personen- und Sachschäden auszuschließen, müssen die Geräte im Fall einer mechanischen und/oder elektrischen Beschädigung unbedingt ausgetauscht werden.

**fr DANGER! TENSION ÉLECTRIQUE DANGEREUSE!**  
L'installation et la mise en service de cet appareil ainsi que toute opération de maintenance doivent être réalisées par une personne qualifiée, dans le respect des normes locales et des dispositions en matière de sécurité. Avant d'installer cet appareil, lisez attentivement cette notice d'utilisation. Ne pas toucher les éléments sous tension. Afin d'éviter des dommages corporels et matériels, les appareils doivent être remplacés en cas de dommage mécanique et/ou électrique.

**it ATTENZIONE! TENSIONE PERICOLOSA!**  
L'installazione e la messa in esercizio di questo apparecchio e tutti gli interventi di manutenzione dovranno essere eseguiti da tecnici qualificati, in osservazione delle norme di legge locali e delle disposizioni di sicurezza. Non toccare le parti in tensione! Per escludere lesioni a persone e danni materiali, sostituire gli apparecchi in caso di danneggiamento meccanico e/o elettrico.

**zh 注意! 电压危险!**  
此设备的安装和运行以及任何保养工作必须由具备资格的专业人员进行，并遵守当地的有关标准和安全规则。在安装此设备前，请仔细阅读这些使用说明。不要触摸带电部件。为避免造成人员伤害和物质损坏，发生机械和/或电气损坏时必须更换设备。

**es ¡ATENCIÓN! ¡TENSION PELIGROSA!**  
La instalación y la puesta en funcionamiento de este dispositivo, así como cualquier trabajo de mantenimiento, deberán ser ejecutados por una persona competente cualificada. En esto, deberán observarse las normas locales y las normas de seguridad. No tocar piezas que se encuentren bajo tensión. Para evitar daños personales y materiales, los dispositivos deberán ser sustituidos al presentar cualquier daño mecánico y/o eléctrico.

**ru ВНИМАНИЕ! ОПАСНОЕ НАПРЯЖЕНИЕ!**  
Монтаж и ввод в эксплуатацию данного прибора, а также любые работы по техобслуживанию, должны производиться квалифицированными специалистами. При этом, необходимо соблюдать местные нормы и правила техники безопасности. Не прикасаться к деталям, которые находятся под напряжением. Чтобы исключить нанесение травм, а также материальные ущербы, в случае механических и/или электрических повреждений приборы необходимо заменить.

**pt ATENÇÃO TENSÃO PERIGOSA!**  
A instalação e operação deste dispositivo e qualquer manutenção devem ser feitas por pessoal qualificado, de acordo com as normas locais e regulamentações de segurança. Antes de instalar este dispositivo, leia com atenção as instruções de operação. Não toque em peças energizadas. Para evitar danos a pessoas e materiais, os dispositivos devem ser substituídos em caso de dano mecânico e/ou elétrico

**ko 주의 위험한 전압!**  
이 장치의 설치 및 작동과 유지 보수는 유자격 직원이 지역 표준 및 안전 규정에 따라 수행해야 합니다. 이 장치를 설치하기 전에, 사용자 매뉴얼을 주의 깊게 읽으십시오. 작동 중인 부품에 손을 대지 마십시오. 인적 및 물적 피해를 방지할 수 있도록 기계적 및/또는 전기적 손상이 발생하는 경우에 장치를 교체해야 합니다.

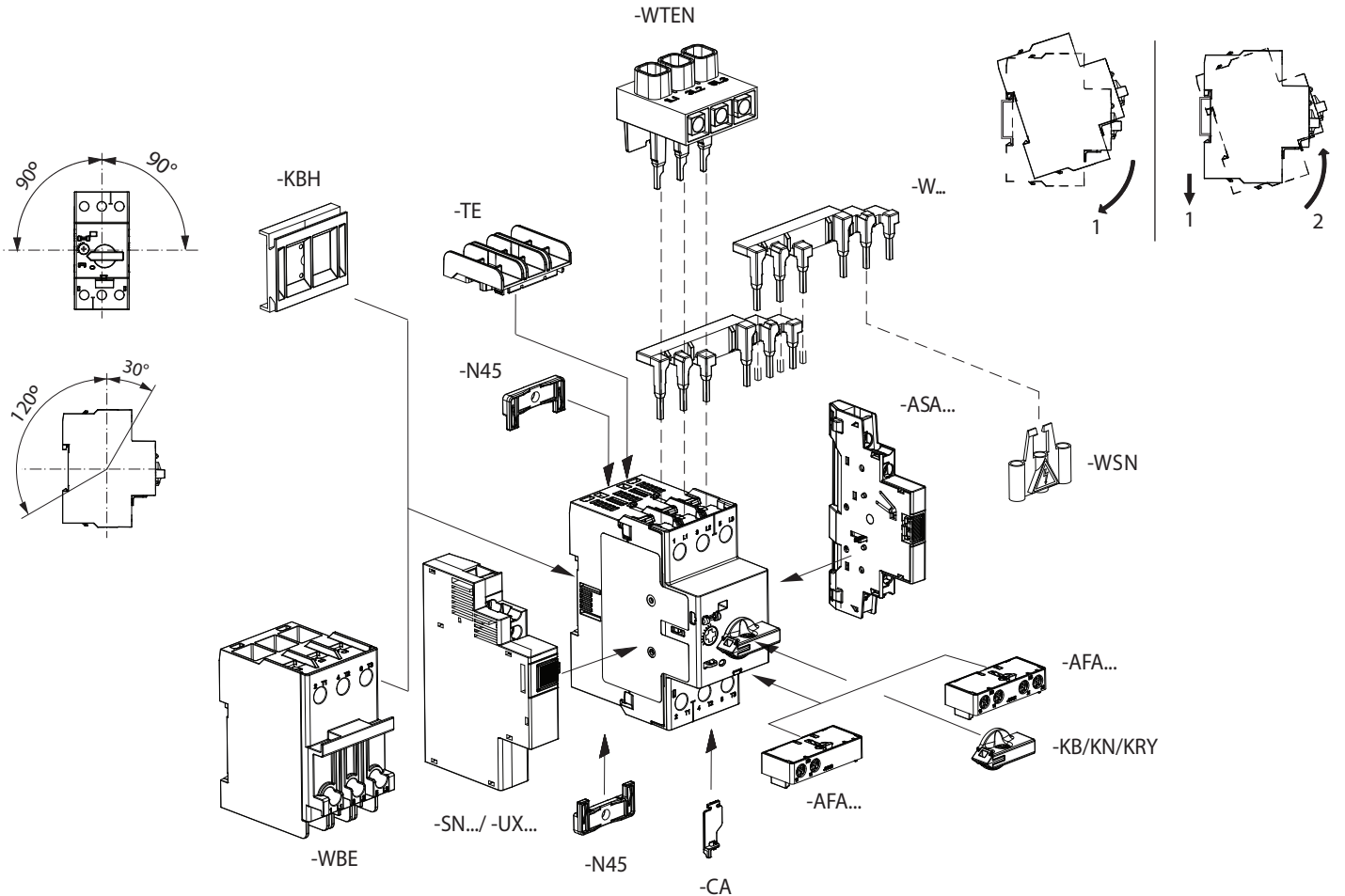

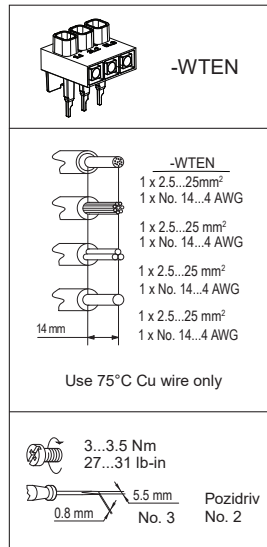
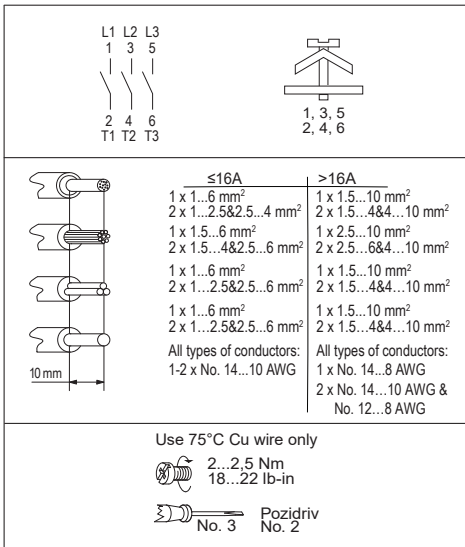

**Steps for a proper connection**

1. Prepare wires according to the instructions
2. Open terminal screws completely
3. Insert wires fully in the correct position
4. Tighten terminal screws with the required torque
5. Check for solid connection by pulling on all the wires

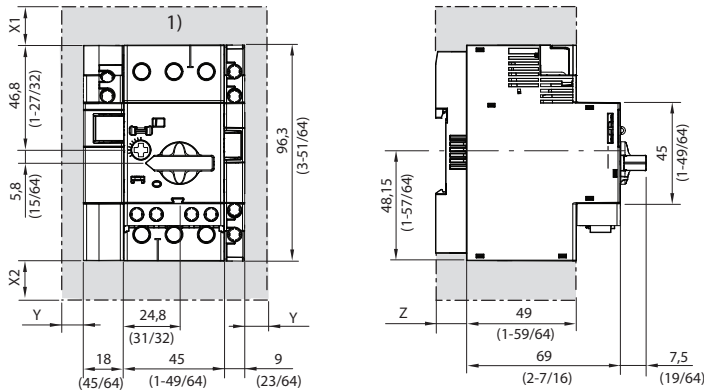

Voltage (V)	X1, X2 mm	inch	Y mm	inch
400	30	1-3/16	9	23/64
500	30	1-3/16	9	23/64
690	50	1-31/32	30	1-3/16

Frame type	Z mm	inch
140MT-C*	7,5	19/64
140MT-D*	13,5	17/32

- 1) Minimum distance to grounded parts or walls (X1, X2, Y)  
 Minimaler Abstand gegen geerdete Teile oder Wände (X1, X2, Y)  
 Distance minimale envers pièces mises à terre ou parois (X1, X2, Y)  
 Distancia mínima per pezzi a massa o pareti (X1, X2, Y)  
 Distancia mínima a chasis o paredes (X1, X2, Y)  
 Минимальное расстояние до заземленных частей или стен (X1, X2, Y)  
 겹쳐 된 부품 또는 벽까지의 최소 거리 (X1, X2, Y)  
 到接地部件或墙面的最小距离 (X1, X2, Y)

**Wiring Diagrams for 1- or 2-Phase Application**

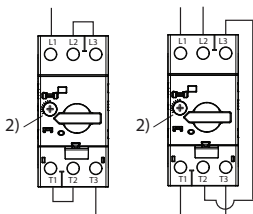

**For 1- or 2-Phase Motor Application**

- 2) Set to 105% of motor current.  
 Stellen Sie 105% des Motorstromes ein.  
 Régler à 105% de la valeur du courant moteur.  
 Regolare a 105% della corrente del motore  
 Ajustar a 105% de la corriente del motor.



**WARNING:** Do not set outside scale !  
**WARNING:** Nicht ausserhalb Skala einstellen !  
**AVERTISSEMENT:** Défense d'ajuster le courant en dehors de la plage indiquée !  
**AVERTENZA:** E vietato di regolare la corrente fuori dal campo di taratura !  
**ADVERTENCIA:** ¡Prohibido de regular la corriente fuera del campo de la escala !  
**ПРЕДУПРЕЖДЕНИЕ:** Выставлять уставку в пределах диапазона!

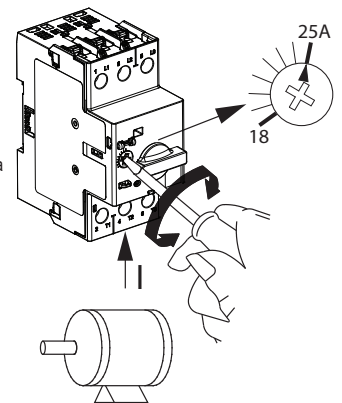

**For UL Control Transformer Protection <sup>3)</sup>**

- The device is to be installed only on the load side of branch circuit protection.
- Set the current adjustment not more than the rated input current of the control transformer.
- Use only in the specific supply voltage system as marked on the device.

**Motor Protection / Circuit Breaker**

This device meets the requirements of IEC 60947-2 as a circuit breaker. It is cULus listed (UL and CSA approved) as:

- A Manual Motor Controller with optional approvals for Group Motor, Motor Disconnect and Tap Conductor Protection.
- A Manual, Self-Protected Combination Motor Controller (Construction Typ. E).

All installations, commissioning and maintenance must be carried out by qualified personnel, taking local regulations into account.

**140MT-D9V-...**

VFD output frequency < 400Hz, PVM frequency  $f_c < 4\text{kHz}$  VFD output frequency < 400Hz, PVM frequency  $f_c < 4\text{kHz}$

Current setting: VFD in = max. input current, VFD out = rated motor current.

For more details see technical specification.

3) Not applicable for 140MT-D9V\*

140MT-D9N\* do not provide thermal protection for themselves nor for downstream components. A separate protective device against thermal overload must be installed, e.g. an O/L relay as part of a starter combination. Refer to derating specification for heavy duty starting.

140MT-D9N\* beinhalten weder für sich selbst noch für nachfolgende Komponenten thermischen Schutz. Gegen thermische Überlast muss ein externes Schutzorgan installiert sein, z.B. ein Überlastrelais als Teil einer Starterkombination. Siehe Derating-Spezifikation für Schweranläufe.

140MT-D9N\* ne sont pas autoprotégés et ne comportent aucune protection contre les surcharges thermiques. Il faut donc prévoir des organes de protection externes comme par expl. des relais thermiques ou électroniques dans les ensembles démarreurs moteurs. Voir spécifications de derating pour démarrages difficiles.

140MT-D9N\* non prevedono alcun tipo di protezione termica, né per se stessi né per i componenti a valle. Pertanto sarà necessario installare un dispositivo di protezione termica separato, quale ad esempio un relè di sovraccarico integrato nel gruppo di avviamento. Riferirsi alla tabella di declassamento per avviamenti gravosi.

140MT-D9N\* carecen de protección térmica propia y para los componentes subsiguientes. Se debe instalar por separado un dispositivo de protección para sobrecargas térmicas, como por ejemplo, un relé de sobrecarga que forme parte de un arrancador de combinación. Consultar la desclasificación correspondiente para arranque duro.

140MT-D9N\* не обеспечивают защиту от перегрузки сами себя а так же компонентов подключенных ниже. Для защиты от перегрузки должно быть установлено дополнительное устройство защиты, например реле перегрузки в составе пускателя. При тяжелых пусках используйте таблицу снижения номинальных рабочих характеристик.

140MT-D9N\* 는 제품 본체 및 하위 회로에 열동형 과전류 보호기능을 제공하지 않습니다. 별도의 과부하 보호 장치(예 : 스타터 조합의 일부인 과부하 계전기)를 추가 설치 해야 합니다. 기동 조건이 예비튜닝에 해당되는 경우 정격보다 높은 사양의 제품으로 선정하십시오.

140MT-D9N\* 不提供本体部份和下级元件的热保护，必须安装单独的热过载保护装置，例如作为起动器组合的部分的过载继电器。对于重载启动，请参考降容说明。

Current range	class 10	class 20	class 30
0.16...10A	no	no	no
16...29A	no	no	1.41
32...40A	no	1.41	1.73

**Short Circuit Ratings**

Cat. No.	USA/CND Manual Motor Controller and Self-Protected Combination Motor Controller					
	Group Motor Installation		Motor Disconnect		Self-Protected Combination Motor Controller and Tap Conductor Protection in Group Installation for Manual Motor Controller	
	480V	600V	480V	600V	480Y/277V	600Y/374V
Allen-Bradley	Max. Short Circuit Current [kA]					
140MT-C3E-A16...B16	65	50	65	50	65	50
140MT-C3E-B25...B40	65	30	65	30	65	30
140MT-C3E-B63...C10	65	30	65	30	65	—
140MT-C3E-C16	30	30	30	30	30	—
140MT-C3E-C20	30	30	10	10	—	—
140MT-C3E-C25	30	18	30	5	—	—
140MT-C3E-C29...C32	30	10	10	—	—	—

Cat. No.	USA/CND Manual Motor Controller and Self-Protected Combination Motor Controller					
	Group Motor Installation		Motor Disconnect		Self-Protected Combination Motor Controller and Tap Conductor Protection in Group Installation for Manual Motor Controller	
	480V	600V	480V	600V	480Y/277	600Y/347V
Allen-Bradley	Max. Short Circuit Current [kA]					
140MT-D9E-A63...B16	65	50	65	50	65	50
140MT-D9E-B25...C20	65	30	65	30	65	30
140MT-D9E-C25...C29	50	30	50	30	50	30
140MT-D9E-C32	50	30	30	18	30	18
140MT-D9E-C36...C40	30	30	30	18	30	—
140MT-D9N-A16...B16	65	50	65	50	—	—
140MT-D9N-B25...C29	65	30	65	30	—	—
140MT-D9N-C32...C40	30	30	30	18	—	—
140MT-D9T-A16...B16	65	50	65	50	65	50
140MT-D9T-B25...C20	65	30	65	30	65	30
140MT-D9T-C25	50	18	50	18	50	18
140MT-D9V-B16...C20	65	—	65	—	65	—
140MT-D9V-C25...C29	50	—	50	—	50	—
140MT-D9V-C32	50	—	30	—	30	—
140MT-D9V-C36...C40	30	—	30	—	30	—

**Ex relevant information**

Explosion Application Cat. No. Type Range: Bul. 140MT-C3E-..., 140MT-D9E-..., 140MT-D9T-..., 140MT-D9V-...  
(140MT-D9N-... is not usable for Ex Applications)

The Ex protection function of the 140MT-C / D devices (Circuit breaker with contactors as starters outside the Ex zone with connection to the Ex zone) is a thermally delayed release device with phase failure protection so that the motor starter acts as a safety device (protective device for indirect temperature monitoring) to protect motors to avoid impermissible temperatures can be used.

Possible Type of Ignition in according to the Zone:

- For Mining: db, eb and pxb
- For Gas: db, eb and pxb
- For Dust: tb and pxb



I (M2) [Ex eb Mb]

II (2) GD [Ex eb Gb]

Multiple of current setting limits for ambient air temperature compensate time-delay overload relays:

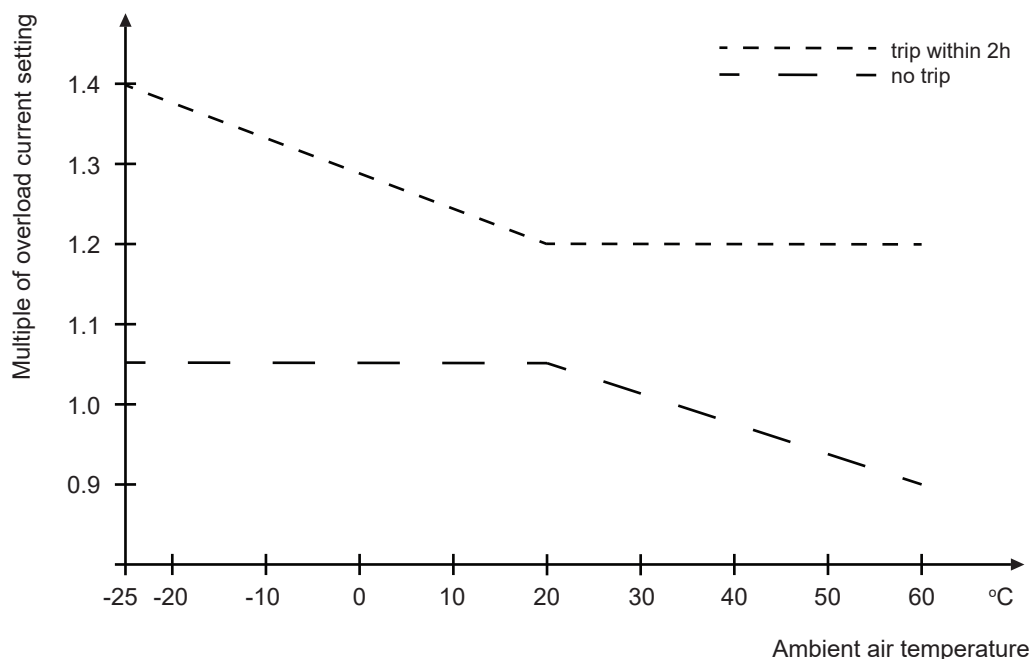

Ex Ambient Specifications:

- Operation at Ta = -25 °C up to +60 °C
- Storage at T= -40 °C up to +80 °C
- SIL 1 necessary requirements for the environment e.g. overvoltage category

Ex Installation and Maintenance:

- Use 60079-14 (for dust additional 61241-14) for Project engineering, selection and installation
- Use 60079-17 for Inspection and maintenance
- No repairing of the 140MT-C/D devices allowed (Because Ex protection function is no longer guaranteed!)
- Where automatic restarting after a failure is not permitted, the user must take suitable measures to prevent restarting.
- With the aid of the device's test function, the tripping mechanism can be tested in the de-energized state.
- The cable type and the conductor cross section of the current leads must be selected so that the thermal limiting temperature for the connecting cables is not exceeded.
- It could be proved in all cases that the motors are safely switched off.

European Hazardous Location Approval. The following applies to products marked II (2) GD and I (M2): Are Equipment Group I and II, Equipment Category 1G, 2G, 1D, 2D and M2 and comply with the Essential Health and Safety. Requirements relating to the design and construction of such equipment given in Annex II to EU Directive 2014/34/EU. See the EU declarations of conformity, safety instruction and certificates on links below. Safety device intended for use outside potentially explosive atmospheres caused by gases, vapors, mist, (coal) dust, and methane are likely to occur in normal operation, but required for, or contributing, the safe functioning (also during expected malfunctions) of equipment and protective systems with respect to the risk of explosion. Such locations correspond to Zone 1, Zone 21 and Mining classification according to ATEX directive 2014/34/EU.

Не предназначено для применения во взрывоопасных зонах. Только для общепромышленного применения.

ATEX/IECEX/UKEx:

A-B: <http://rok.auto/certifications>



## Warnings

**WARNING:** The opening of the branch-circuit protective device may be an indication that a fault current has been interrupted. To reduce the risk of fire or electric shock, current-carrying parts and other components of the controller shall be examined and replaced if damaged.

**AVERTISSEMENT** — Le déclenchement du dispositif de protection de la dérivation peut signifier qu'un courant de fuite a été interrompu. Pour réduire les risques d'incendie et de choc électrique, les pièces porteuses de courant et autres pièces de la commande doivent être examinées et remplacées au besoin.

**WARNING:** To maintain overcurrent, short-circuit, and ground-fault protection, the manufacturer's instructions for selection of overload and short-circuit protection must be followed to reduce the risk of fire or electric shock.

**AVERTISSEMENT** — Pour assurer une protection continue contre les surintensités, les courts-circuits et les fuites à la terre, les instructions du fabricant relatives à la sélection d'une protection contre la surcharge et les courts-circuits doivent être respectées afin de réduire le risque d'incendie et ou de choc électrique.

**WARNING:** When an overload or a fault current interruption occurs, circuits must be checked to determine the cause of the interruption. When a fault condition exists, the current-carrying components should be examined and replaced when damaged, and the integral current sensors must be replaced to reduce the risk of fire or electric shock.

**AVERTISSEMENT** — En cas d'intervention due à une surcharge ou un courant de défaut, les circuits doivent être vérifiés pour déterminer la cause de l'interruption. En condition de défaut, les composants porteurs de courant devraient être examinés et remplacés au besoin, et les capteurs de courant intégrés doivent être remplacés afin de réduire le risque d'incendie et ou de choc électrique.

---

Transport, Storage, Installation and operation according to this document, product catalog and product standard. Follow national/local regulations.

제품의 운반, 보관, 설치 및 사용은 이 문서 및 제품 카탈로그와 제품 표준에 따라서 하십시오. 해당 국가/로컬의 법규를 따르십시오.

The product has no serviceable parts. Replace if faulty.

이 제품은 수리가 가능한 부품을 포함하고있지 않습니다. 이상이 있을시 제품을 교체하십시오.

Check regularly the tightness of all terminals and bus bar connections.

모든 연결단자 및 버스바 연결부분의 체결상태를 정기적으로 점검 하십시오.

## ОСТОРОЖНО! Опасное напряжение!

Монтаж и ввод в эксплуатацию данного прибора, а также любые работы по техобслуживанию, должны производиться квалифицированными специалистами. При этом необходимо соблюдать местные нормы и правила техники безопасности. Перед тем, как производить монтаж прибора необходимо ознакомиться с данным руководством. Не прикасаться к деталям, которые находятся под напряжением чтобы исключить получения травм и нанесения материального ущерба. Должны быть приняты меры для предотвращения повреждения устройств. В случае наличия механических и/или электрических повреждений приборы бракуются. Данное руководство не охватывает всю подробную информацию к типу и не может учитывать каждый отдельный случай применения изделия.

### Техническое обслуживание

Техническое обслуживание включает в себя периодический внешний осмотр, очистку от пыли, протяжку резьбовых соединений. При внешнем осмотре проверить выключатель на отсутствие механических повреждений.

### Средний срок службы изделия

Средний срок службы устанавливается 20 лет при соблюдении потребителем условий эксплуатации, транспортировки и хранения.

### Сведения об утилизации

После окончания эксплуатации выключатели подлежат разборке и сортировке на цветные и черные металлы. Применяемые в конструкции выключателей материалы не содержат взрыво- и пожароопасных токсичных и вредных веществ и подлежат утилизации в установленном в регионах порядке. Утилизируемые материалы не являются опасными для окружающей среды.

### Сведения о маркировке

На изделие наносится товарный знак "Allen-Bradley", наименование продукции, код даты изготовления и Единый знак обращения продукции на рынке государств- членов ЕАЭС.





### Сведения о производителе

Rockwell Automation, Inc., 1201 South 2nd Street, Milwaukee, WI 53204, USA, Телефон: +1-414-382-2000, факс: +7-414-382-4444 на заводе-изготовителе Rockwell Automation Sp. z o.o., ul. Roździeńska 49, 40-382 Katowice, Польша.

### Уполномоченный представитель изготовителя на территории ЕАЭС:

ООО «Роквелл Аутомейшн», 1107061, Россия, город Москва, Преображенская площадь, дом 8, этаж 18

Тел +7 (495) 825 00 25

Connect with us.    

For Technical Support, visit [rok.auto/support](http://rok.auto/support).

Rockwell Automation maintains current product environmental compliance information on its website at [rok.auto/pec](http://rok.auto/pec).

Product certificates are located in the Rockwell Automation Literature Library: [rok.auto/certifications](http://rok.auto/certifications).

Rockwell Otomasyon Ticaret A.Ş., Kar Plaza İş Merkezi E Blok Kat:6 34752 İçerenköy, İstanbul, Tel: +90 (216) 5698400

EEE Yönetmeliğine Uygundur.

**rockwellautomation.com**

expanding human possibility™

AMERICAS: Rockwell Automation, 1201 South Second Street, Milwaukee, WI 53204-2496 USA, Tel: 414.382.2000, Fax: (1) 414.382.4444

EUROPE/MIDDLE EAST/AFRICA: Rockwell Automation NV, Pegasus Park, De Kleetlan 12a, 1831 Diegem, Belgium, Tel: (32) 2663 0600, Fax: (32) 2663 0640

ASIA PACIFIC: Rockwell Automation, Level 14, Core F, Cyberport 3, 100 Cyberport Road, Hong Kong, Tel: (852) 2887 4788, Fax: (852) 2501846

Publication 140MT-IN011A-MU-P - April 2021

Copyright © 2021 Rockwell Automation, Inc. All Rights Reserved. Printed in USA.



PN-617950

DIR 10006010736 (Version 00)