

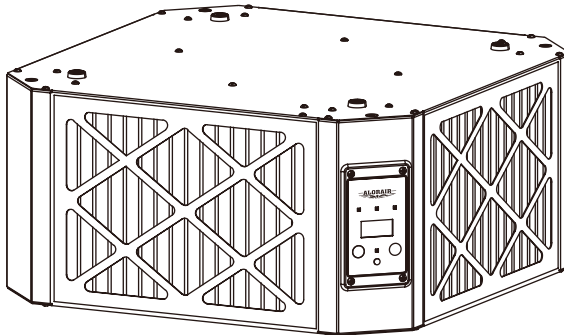

PureCare 1350IG/1350

AIR FILTRATION SYSTEM

Installation and User Manual



READ AND SAVE THESE INSTRUCTIONS

AlorAir Solutions INC.
Add: 14752 Yorba Ct Chino CA 91710 US
Tel: +1 888-990-7469
Email: sales@alorair.com

DIRECTORY

SPECIFICATIONS	1
DESCRIPTION	1
SAFETY RULES	2
ELECTRICAL SAFETY	3
WARRANTY EXCLUSIONS	4
KNOW YOUR AIR FILTRATION SYSTEM	5
ASSEMBLY AND ADJUSTMENTS	5
OPERATION	7
MAINTENANCE	8
CHECK AND TROUBLESHOOT	9
WIRING DIAGRAM	9
LIMITED WARRANTY	10
WARRANTY EXCLUSIONS	11

SPECIFICATIONS

Motor115 V / 60 Hz 1.5 Amps max.
Airflow1050 / 1350 CFM
FiltersMERV-11 (90% 3-10 μ m 85% 1 μ m)
Max Remote Control Distance27 ft
Weight27 lbs
Dimensions (W \times H \times D)20.5" \times 20.5" \times 9.8"

PureCare 1350IG has the function of removing ozone and belongs to the plasma model.

DESCRIPTION

Your new tool has been engineered and manufactured to AlorAir's highest standards for dependability, ease of operation, and operator safety. When properly cared for, this product will supply you years of rugged, trouble-free performance. Pay close attention to the rules for safe operation, warnings, and cautions. If you use your tool properly and for intended purpose, you will enjoy years of safe, reliable service.

The machine is equipped with four lightweight filtering devices to avoid the unnecessary increase in weight and volume increase. It effectively enhances the air purification capability that allows to the filtration of small particles such as dust, sawdust, and many more.

HOW IT WORKS

1. Connect the dust collector to a standard 115 V / 60 Hz outlet.
2. Refrain from moving the unit during operation.
3. Keep both air inlet and outlet away from the wall or any obstructions for at least 2 ft.
4. This product can only filter dust particles above 1 μ m.

SAFETY RULES

▲WARNING: To avoid mistakes and serious injury, do not plug in your tool until the following steps have been read and understood.

1. DO NOT use power tools in the presence of flammable liquids or gases.
2. KEEP BYSTANDERS AT A SAFE DISTANCE from the work area, especially when the tool is operating. NEVER allow children or pets near the tool.
3. DRESS FOR SAFETY. Do not wear loose clothing, gloves, neckties, or jewelry (ring, watches, etc.) when operating the tool. Inappropriate clothing and items can get caught in moving parts and draw you in. ALWAYS wear non-slip-footwear and tie back long hair.
4. WEAR A FACE MASK OR DUST MASK to fight the dust produced by sawing operations.

▲WARNING: Dust generated from certain materials can be hazardous to your health. Always operate the tool in a well-ventilated area and provide for proper dust removal. Use dust collection systems whenever possible.

1. ALWAYS remove the power cord plug from the electrical outlet when making adjustments, changing parts, cleaning, or working on the tool.
2. AVOID ACCIDENTAL START-UPS. Make sure the power switch is in the OFF position before plugging in the power cord.
3. REMOVE, ADJUSTMENT TOOLS. Always make sure all adjustment tools are removed from the saw before turning it on.
4. NEVER STAND ON A TOOL. Serious injury could result if the tool tips or is accidentally hit. DO NOT store anything above or near the tool.
5. Follow instructions for changing accessories.
6. CHECK FOR DAMAGED PARTS. Check for alignment of moving parts, jamming, breakage, improper mounting, or any other conditions that may affect the tool's operation. Any part that is damaged should be properly repaired or replaced before use.
7. DO NOT operate the tool if you are under the influence of drugs, alcohol, or medication that may affect your ability to properly use the tool.
8. USE SAFETY GOGGLES AT ALL TIMES that comply with ANSI Z87.1. Normal safety glasses only have impact resistant lenses and are not designed for safety. Wear a face or dust mask when working in a dusty environment. Use ear protection such as plugs or muffs during extended periods of operation.
9. Do not use the air filter in environments that have poisonous gases, fumes, noxious smoke, or other chemical risks. This filtration system is only designed to filter dust, airborne bacteria, small particles, etc.

ELECTRICAL SAFETY

▲ EQUIPMENT MUST BE GROUNDED.

IN THE EVENT OF A MALFUNCTION OR BREAKDOWN, grounding provides the path of least resistance for an electric current and reduces the risk of electric shock. This tool is equipped with an electric cord that has an equipment grounding conductor and a grounding plug. The plug **MUST** be plugged into a matching outlet that is properly installed and grounded in accordance with ALL local codes and ordinances.

DO NOT MODIFY THE PLUG PROVIDED. If it will not fit the outlet, have the proper outlet installed by a licensed electrician.

IMPROPER CONNECTION of the equipment grounding conductor can result in electric shock. The conductor with the green insulation (with or without yellow stripes) is the equipment grounding conductor. If repair or replacement of the electric cord or plug is necessary, **DO NOT** connect the equipment grounding conductor to a live terminal.

CHECK with a licensed electrician or service personnel if you do not completely understand the grounding instructions or whether the tool is properly grounded.

▲ WARNING: This tool is for indoor use only. Do not expose to rain or use in damp locations.

- Make sure your extension cord is properly wired and in good condition.
- Protect your extension cords from sharp objects, excessive heat, and damp/wet areas.
- Use a separate electrical circuit for your tools. This circuit must not be less than a #12 wire and should be protected with a 15 A time-delayed fuse.
- Before connecting the motor to the power line, make sure the switch is in the OFF position and the electric current is rated the same as the current stamped on the motor nameplate. Running at a lower voltage will damage the motor.

WARRANTY EXCLUSIONS

▲WARNING!

Please note that the dust remover can only be used with accessories approved by AlorAir. Using unauthorized accessories or making changes to the machine may void your warranty. Please contact us for details. DAMAGE DUE TO THE FOLLOWING IS NOT covered under warranty.

1. Acts of Nature including but not limited to: Flooding, Fire, Water damage, Hurricane/storm damage.
2. IMPROPER USAGE Including but not limited to: Misuse, abuse, or tampering whether intentional or accidental, Improper installation, Improper voltage, Improper maintenance, Failure to follow instructions.
3. Corrosion, Freezing.
4. Any additional costs due to changes in laws or building codes.
5. Freight charges.
6. Any costs due to lost profit or delay.
7. Damage to property.
8. Cause beyond control.
9. Consumable parts, including but not limited to: Filters, Batteries, Power cords, Valves. Switches, Rubber parts.
10. Direct, indirect, collateral or inconsequential damages of any kind.

THE WARRANTIES AND LIABILITIES SET FORTH ARE IN LIEU OF ALL OTHER WARRANTIES EXPRESSED OR IMPLIED, IN LAW OR IN FACT, INCLUDING IMPLIED WARRANTIES OF MERCHANTABILITY AND FITNESS FOR A PARTICULAR PURPOSE.

ALORAIR SHALL IN NO EVENT BE LIABLE FOR DEATH, INJURIES TO PERSONS OR PROPERTY, OR FOR INCIDENTAL, CONTINGENT, SPECIAL, OR CONSEQUENTIAL DAMAGES ARISING FROM THE USE OF OUR PRODUCTS. SOME STATES DO NOT ALLOW THE EXCLUSION OR LIMITATION OF INCIDENTAL OR CONSEQUENTIAL DAMAGES, SO THE ABOVE LIMITATION OR EXCLUSION MAY NOT APPLY TO YOU.

AlorAir total liability, regardless of nature of claim shall not exceed original purchase price of the product. If a product or component is replaced while under warranty, the applicable warranty period shall not be extended beyond the original warranty time period.

The foregoing shall constitute the total liability of seller in the case of defective performance of all or any of the equipment or services provided to Buyer. Buyer agrees to accept and hereby accepts the foregoing as the sole and exclusive remedy for any breach or alleged breach of warranty by Seller.

Any dishonesty or fraud in connection with AlorAir warranty thoroughly voids all warranty policies. AlorAir expressly reserves the right to pursue legal action in the event of dishonesty, fraud, or attempted fraud.

KNOW YOUR AIR FILTRATION SYSTEM

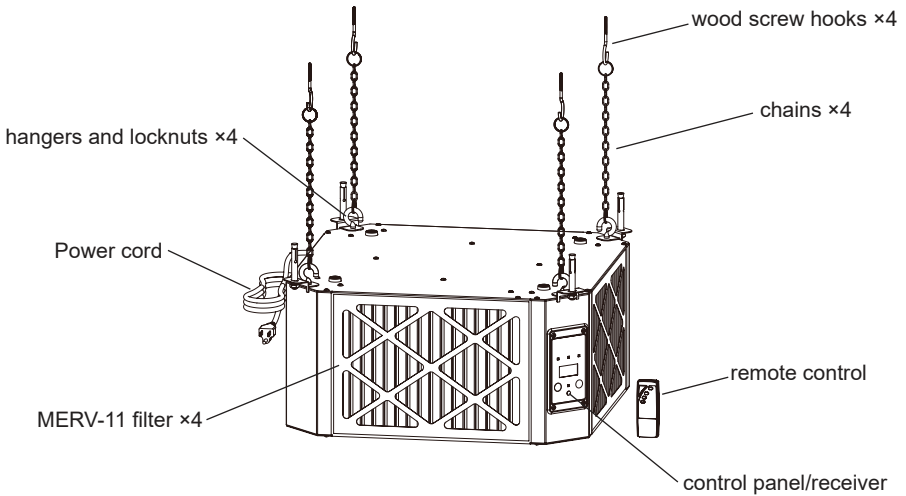

▲ Carefully unpack the air filter and all its parts. Do not discard the carton or any packaging until the air filter is completely assembled.

ASSEMBLY AND ADJUSTMENTS

The air filter is designed to circulate air and filter wood and other non-metallic dust. The unit requires only minimal assembly. However, it is important to consider how and where to place the unit. When selecting a site, make sure there is a suitable power source nearby. Do not use extension cords with the air filter.

▲ Warning!

- Two people are required for installation.
- Do not run the machine without a filter installed.

HANGER PLACEMENT (Fig. 1)

1. Thread the locknuts ① almost all the way up the hanger ② .
2. Thread a hanger into each of the four mounting holes ③ on the top of the air filter cabinet.
3. Tighten catch locknut against the cabinet top. Hold the hangers so that they do not spin while tightening the locknut.

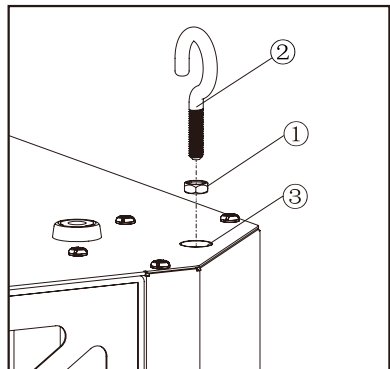

Fig. 1

CEILING PLACEMENT (Fig. 2)

Make sure the unit will be situated at least 7' above the floor and at least 3' away from a corner and from any heating or air vents.

1. Install the wood screw hooks ② into the building support structure ① . Do not mount the air filter to non-structural surfaces such as drywall or false ceiling grids. The hooks are rated for this air filter and can support a maximum of 100 lbs.
2. Place a chain ③ on each wood screw hook ② .
3. Attach the hangers ④ on each chain ③ .
4. Make sure the unit is level horizontally, and is at least 7' above the floor. If it is not, remove the air filter and adjust the length of the chain as needed. Then remount the unit.
5. Plug the air filter power cord directly into a power source.

Note: the above installation must be installed by no less than two people!

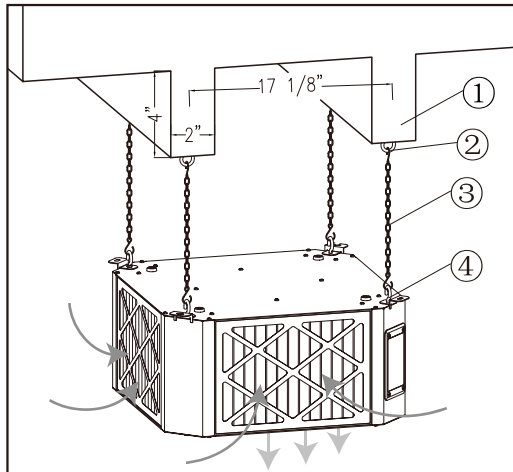

Fig. 2

When you install the unit, you may also put the air outlet to up. (You need to remove the control panel, and turn around 180°, then install back again.)

OPERATION

The air filter can be operated directly using the control panel or with the remote control.

The Air filter with power off memory function, power off after the boot again, will repeat the last operation.

TURN ON AIR FILTER AND SPEED SETTINGS (Fig. 3 and 4)

1. Plug the power cord into an appropriate power source.
2. Press the “ON/OFF” button ① On the control panel or the “ON/OFF” button ① On the remote control to switch ON the POWER supply of the air filter. The POWER indicator light ③ is ON, and the dust filter is operated before the last shutdown (except the scheduled shutdown).
3. Press the “SPEED” button ② on the control panel or the button ② on the remote control to set the SPEED of dust filter and the SPEED selected by the LOW/HIGH ④ / ⑥ indicator on the control panel.
4. Press ionizer button ⑦ on the remote control to turn ionizer indicator ⑤ on or off.

Note: The PureCare 1350 does not have this feature and the Ionizer button on the remote is not responding!

5. Press the timer shutdown button ⑧ on the remote control to enter the timer shutdown.

Dust filter in ON (continuous operation) mode, press timing shutdown button ⑧, enter the timing shutdown of 1H to 9H, for example, set at 6H, 6H display in flashing 5 seconds, start timing shutdown. --H is to cancel the timed shutdown. After --H blinks for 5 seconds (or press the timed shutdown button when --H blinks), cancel the timed shutdown and enter ON.

In the dust filter timed shutdown mode (such as 05:39), press the timed shutdown button ⑧, the current time blinks, no operation within 5 seconds, and the current timer is restored (05:39). Press the timer shutdown button within 5 seconds of blinking to enter

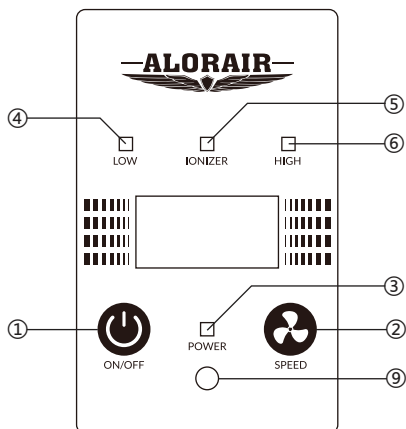

Fig. 3

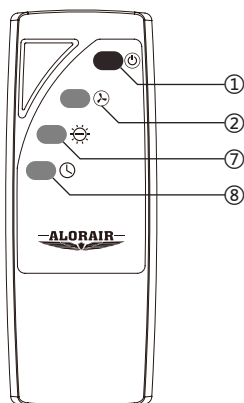

Fig. 4

the timer shutdown (1H - 9H) setting. When entering the --H display, --H flashes for 5 seconds, no operation is performed within 5 seconds, and the ON mode is entered.

--H blinking press the timer shutdown button within 5 seconds to cancel the setting and return to the countdown (05:39).

Note: The unit will automatically shut down after a selected time interval.

6. The infrared receiving opening ⑨ on the control panel should not be blocked by objects or dirt.

MAINTENANCE

▲WARNING: To reduce the risk of injury and electric shock, unplug the air filtration system from the power source before changing the air filters or servicing the unit.

CHANGE THE FILTERS

Check the inner and outer filters periodically, depending on the amount of use, and change the filters when needed. Clogged filters will reduce the amount of air circulating through the filter.

1. When the device is powered off, take it to the middle of the filter ① and take it out externally.

Note: Wear a mask and gloves when changing filters.

2. Take out the new filter and place it in the device according to the direction indicated.

Note: when the operating distance of the remote control is significantly shortened, please replace the battery of the remote control and wipe the infrared receiver in time!

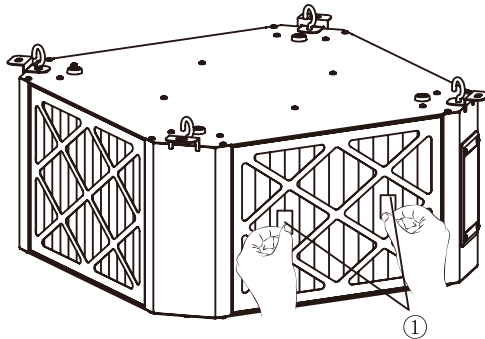

Replacement filters for this unit available at www.alorair.com and all online retailers where this unit is sold.

CHECK AND TROUBLESHOOT

1. According to your operating environment, the equipment may be blocked by the filter, resulting in noise. Please replace the filter in time.
2. Excessive current or abnormal family circuit will lead to power off protector connected. Equipment power, protect your circuit.

CIRCUIT BREAKER RECOVERY

1. Disconnect the power supply.
2. Press the circuit breaker ① back to its original position.
3. Switch on the power supply and start the machine.

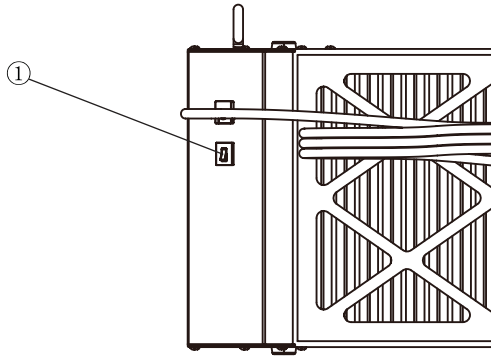

WIRING DIAGRAM

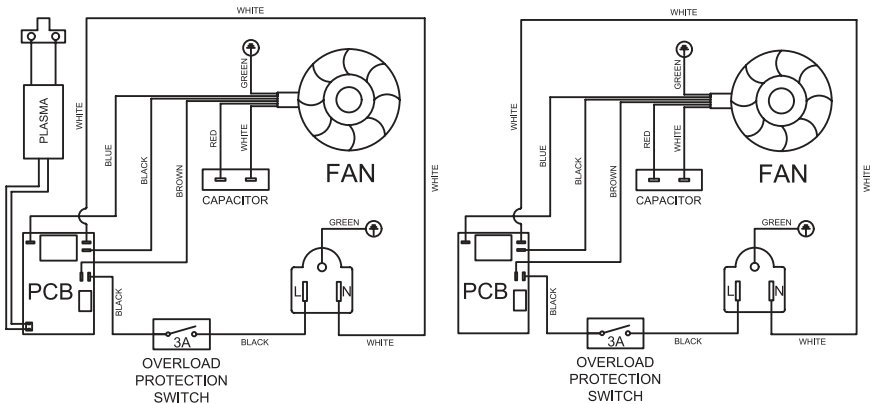

LIMITED WARRANTY

The limited warranty is applicable to the original purchaser only, since the date of purchase. It should be subject to the terms and conditions listed in this limited warranty file.

WARRANTY PERIOD

Warranty becomes effective from the date of original purchase and will last for one year. This limited warranty is not transferable. It is only valid for the original purchaser.

- **Warranty debarment:**

1. Damage caused by the owner when attempting to fix or alter the product by himself or herself.
2. Damage caused by misuse, abuse, neglect, alterations or unauthorized repair.
3. Natural depreciation.

- **How to request warranty services?**

To obtain the benefit of this warranty, please leave your message online web: www.alorair.com or send an email to support@alorair.com.

Our customer service will address your issue between Mon-Fri 7:00 AM to 4:00 PM PST.

AlorAir Warranty Steps:

1. Upon receiving this item, visit www.alorair.com and fill out the warranty registration form. The order number is required to submit a warranty claim.
2. To request warranty service, contact support@alorair.com.
3. After receiving the warranty service request, our customer support team will investigate the issue. Here, it will be determined if a Return authorization is necessary.
4. If the damage to the machine is proven to be one of the warranty exclusions (Page 10), AlorAir will not be responsible for all the associated repair and shipping costs. The eligibility of a replacement unit will also be voided.
5. If the damaged unit that can no longer be fixed is within the warranty period, AlorAir will handle all the cost to send a brand-new replacement unit.
6. When the unit is repaired or replaced, the original warranty period carries over to the repaired or new unit. No warranty extensions will be offered.

WARRANTY EXCLUSIONS

DAMAGE DUE TO THE FOLLOWING IS NOT covered under warranty:

1. Acts of Nature including but not limited to:
 - Flooding, Fire, Water damage, Hurricane/storm damage.
2. IMPROPER USAGE, Including but not limited to:
 - Misuse, abuse, or tampering whether intentional or accidental
 - Improper installation
 - Improper voltage
 - Improper maintenance
 - Failure to follow instructions
3. Corrosion
4. Freezing
5. Any additional costs due to changes in laws or building codes
6. Freight charges
7. Any costs due to lost profit or delay
8. Damage to property
9. Cause beyond control
10. Consumable parts, including but not limited to:
 - Filters, Batteries, Power cords, Valves, Switches, Rubber parts.
11. Direct, indirect, collateral or inconsequential damages of any kind.

THE WARRANTIES AND LIABILITIES SET FORTH ARE IN LIEU OF ALL OTHER WARRANTIES EXPRESSED OR IMPLIED, IN LAW OR IN FACT, INCLUDING IMPLIED WARRANTIES OF MERCHANTABILITY AND FITNESS FOR A PARTICULAR PURPOSE.

AlorAir total liability, regardless of nature of claim shall not exceed original purchase price of the product. If a product or component is replaced while under warranty, the applicable warranty period shall not be extended beyond the original warranty lime period.

The foregoing shall constitute the total liability of seller in the case of defective performance of all or any of the equipment or services provided to Buyer. Buyer agrees to accept and hereby accepts the foregoing as the sole and exclusive remedy for any breach or alleged breach of warranty by Seller.

Any dishonesty or fraud in connection with AlorAir warranty thoroughly voids all warranty policies. AlorAir expressly reserves the right to pursue legal action in the event of dishonesty, fraud, or attempted fraud.



AlorAir Solutions INC.
Add: 14752 Yorba Ct Chino CA 91710 US
Tel: +1 888-990-7469
Email: sales@alorair.com