



# SmartHome

1080P Wi-Fi Video Doorbell

User Manual



V 1.0.0





# Table of Contents

Legal Statement.....	2
Important Safeguards and Warnings.....	3
Device Introduction.....	4
Physical Installation.....	9
Amcrest Smart Home App Setup.....	13
Amcrest Smart Home Cloud.....	20
MicroSD Card Recording.....	24
App Settings.....	25
Motion Detection Overview.....	27
Events Menu.....	37
Account Menu.....	38
Adding to Blue Iris.....	43
Adding to An Amcrest NVR/DVR.....	44
Adding to Amcrest View Pro.....	45
Technical Specifications.....	46
Troubleshooting.....	47



# Legal Statement

**Caution:** The user is cautioned that changes or modifications not expressly approved by the party responsible for compliance could void the user's authority to operate the equipment.

**Note:** This equipment has been tested and found to comply with the limits for a Class B digital device, pursuant to part 15 of the FCC Rules. These limits are designed to provide reasonable protection against harmful interference in a residential installation. This equipment generates uses and can radiate radio frequency energy and, if not installed and used in accordance with the instructions, may cause harmful interference to radio communications. However, there is no guarantee that interference will not occur in a particular installation. If this equipment does not cause harmful interference to radio or television reception, which can be determined by turning the equipment off and on, the user is encouraged to try to correct the interference by one or more of the following measures:

- Reorient or relocate the receiving antenna.
- Increase the separation between the equipment and receiver.
- Connect the equipment into an outlet on a circuit different from that to which the receiver is connected.
- Consult the dealer or an experienced radio/TV technician for help.

## **FCC RF Radiation Exposure Statement:**

This equipment complies with FCC radiation exposure limits set forth for an uncontrolled environment. This equipment should be installed and operated with a minimum distance of 20cm between a radiator or any part of your body.

This device complies with Part 15 of the FCC Rules. Operation is subject to the following two conditions:

- (1) This device may not cause harmful interference, and
- (2) This device must accept any interference received, including interference that may cause undesired operation.

## **About This Document**

- This document is for reference purposes only. Please refer to the actual product documentation for more details.
- This document may serve as a reference for other product types whose specific operations will not be enumerated. Please operate according to actual product specifications.
- Amcrest reserves rights to revise any information in this document at anytime; and the revised contents will be added to the new version without prior announcement. Some functions of the product may be slightly different before and after a revision.
- This document includes general practice, installation examples, and technical content that may be used for your device. Installation of this device may differ based on specific locations.
- Working with electricity can be dangerous if proper safety precautions are not taken. If you are not comfortable or inexperienced with the tools or process described in this manual, we highly recommend hiring a licensed electrician to install your device. Amcrest does not assume liability for any damage that result in improper use or installation of your device.



# Important Safeguards and Warnings

The following description is the correct application method for the device. Please read the manual carefully before use to prevent damage or property loss.

## Operating Requirements

- Do not place or install the device in an areas of high exposure to direct sunlight or near high heat generating devices.
- Do not install the device in areas of high humidity, dust, or fuliginous areas.
- The device must be installed horizontally or installed in a stable place that will prevent the device from falling.
- Do not drip or splash liquids into the device. Do not submerge the device in any liquids.
- Install the device in a well ventilated place free from obstruction.
- Only use the device within rated input and output voltage ranges.
- Ensure the power breaker to the installation source is turned off before installing the device.
- Do not attempt to disassemble or repair the device. If the device is defective, please consult Amcrest directly for any replacement or repairs.
- Do not transport, use, or store the device in areas that exceed the recommended humidity and temperature ranges.

## Power Requirements

- The device is designed to operate with existing doorbell wiring, transformers, and chime. If the installation area does not have existing doorbell wiring or suitable voltage, please consult an electrician to replace or install proper doorbell wiring.
- The device requires 16-24V AC to function. A transformer with 16-30V AC will be suitable to power the device.
- If a power adapter is being used to power your doorbell, ensure the power supply meets SELV (safety extra low voltage) requirements and its rated voltage conforms to Limited Power Source in IEC60950-1. For specific power supply requirements, please refer to the device's label sticker.
- This device does not require the use of additional diodes or resistors to function. It is highly recommended to consult an electrician to establish a proper wired electrical connection for your doorbell if existing wiring is not available.



# Device Introduction

## What's Included?

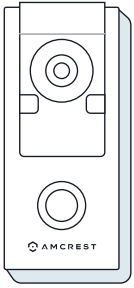

Wi-Fi Doorbell

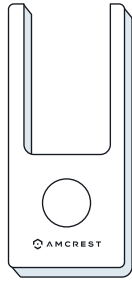

2 Faceplates

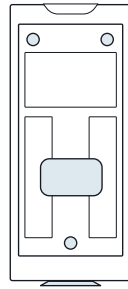

Mounting Bracket



Chime Kit

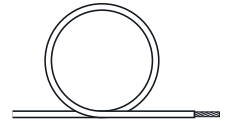

2 Wire  
Extenders



4 Mounting  
Screws



2 Terminal  
Screws



Bracket Screw

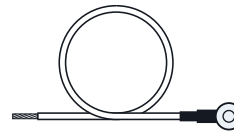

2 Extra Wires



Wire Connector



2 Wire Nuts



4 Wall Anchors

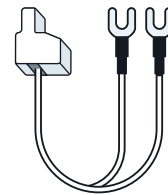

Wire Harness

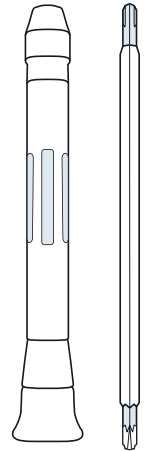

Screwdriver



**NOTE** A 15/64 masonry drill bit will be required if installing on concrete stucco or brick.

# Front Panel

The front panel of the device includes PIR detection sensors, IR lights, camera, microphone, speaker, indicator light, and a call button.

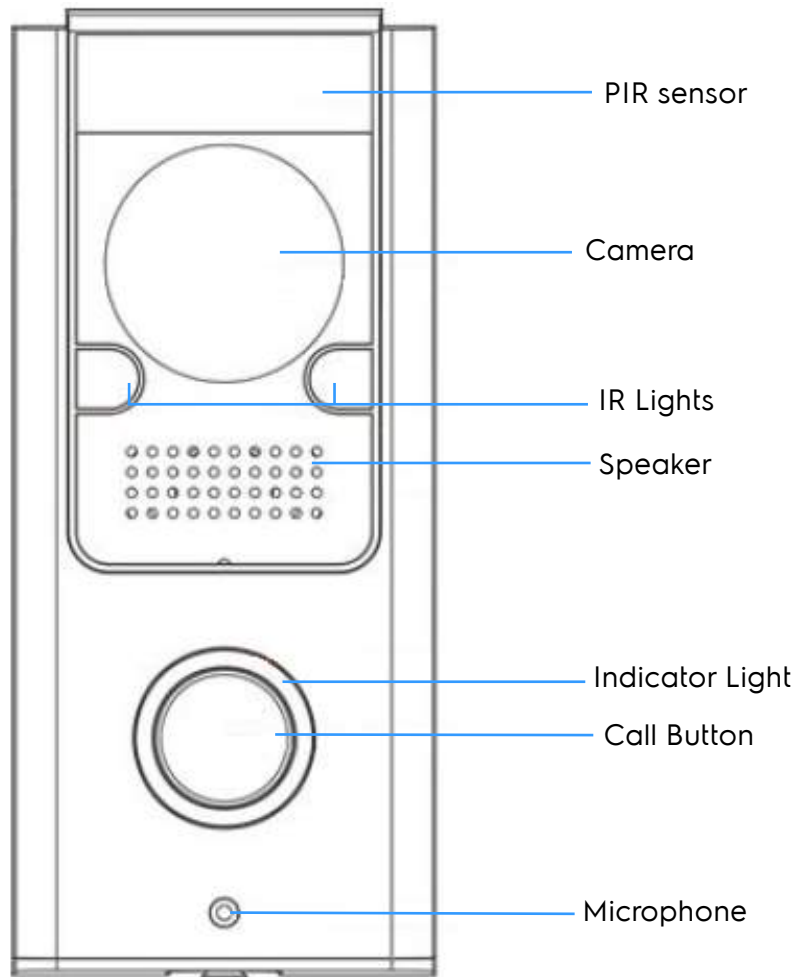

## Indicator Light Description

The indicator light on the front of the device will display specific status details of the device. For a description of each status please refer to the information provided below.



A solid LED indicates that the Wi-Fi doorbell is properly connected to the Wi-Fi network. If the light on the front is solid no further action needs to be taken and the doorbell is properly added into the app.

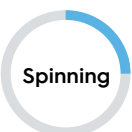

A spinning LED indicates the Wi-Fi doorbell is in setup mode and is currently not connected to a network. Please follow the installation instructions in the Amcrest Smart Home app to continue.



If there is no LED on the front of the doorbell check that the terminals on the back of your doorbell and make sure they are properly connected to the wires and that your doorbell system meets the necessary power requirements (16 volts AC at 30 VA).

## Rear Panel

The rear panel of the device includes a microSD card slot, reset/config button, as well as power input ports which act as a power terminal for your device.

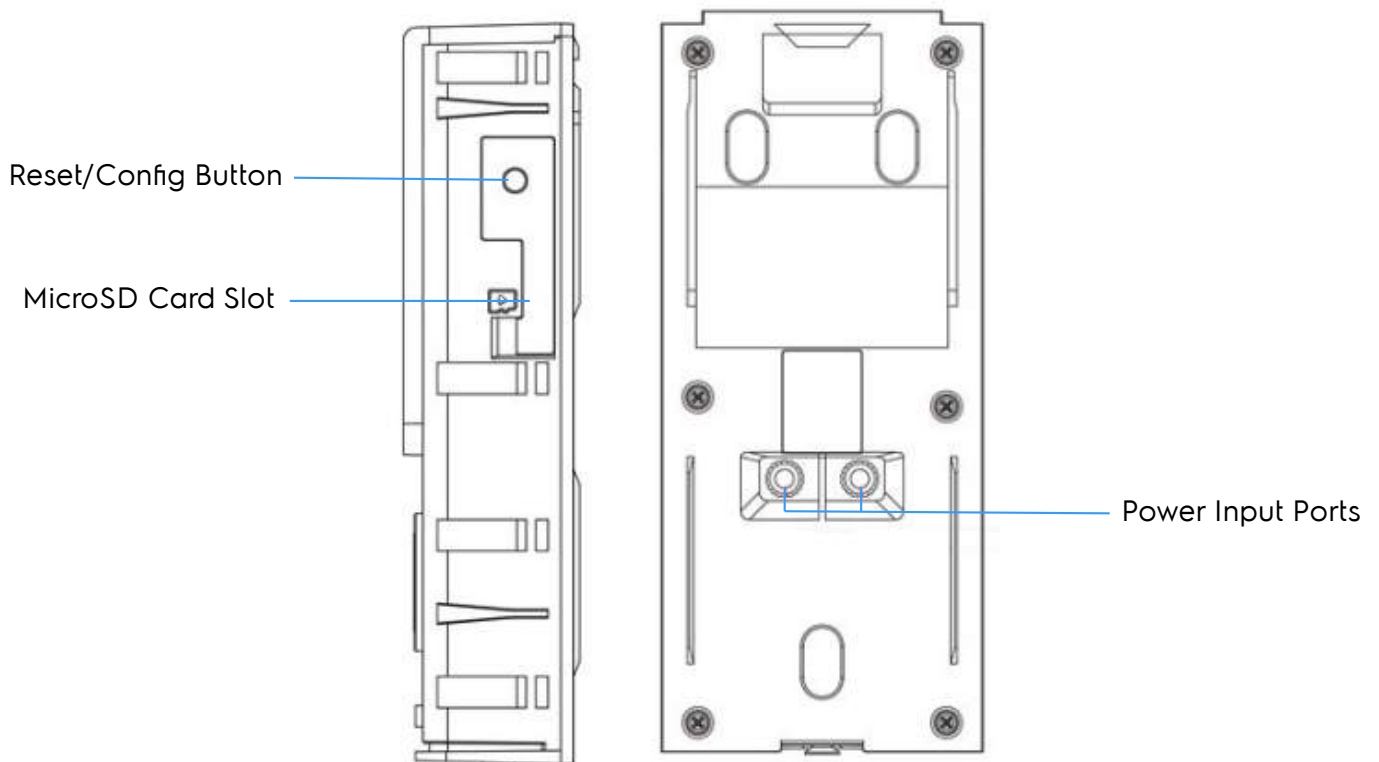

## Reset/Config Button

- The reset/config button will be used to establish an initial connection during setup. When pressed the device will broadcast a hotspot connection which will be used to connect the device to the mobile app. A blue spinning light will be represented on the indicator light located on the front of your device.
- The reset/config button can also be used to factory reset your device. Performing a factory reset will revert your device back to its original factory settings. To perform a factory reset the device must be bound and deleted from your Amcrest Smart Home account. To perform a factory reset, press and hold the reset/config button for 10 seconds and release, allowing the device to reset. Once reset the indicator light on the front of the device will blink indicating the device has been reset and ready to connect.

## Power Input Ports

The power input ports are used to house the power cables and terminal screws for your device. The device is compatible with a standard 16-24V AC or 12V-24V DC power adapter. A power adapter is not included with the doorbell however can be purchased separately, either through Amcrest or a third party source.

- With an AC 16V-24V power source the device can connect and function with a wired or wireless chime (mechanical and electrical) using the included Chime Kit. Anything below the recommended voltage level will result in the system not providing enough voltage to the chime. This will cause the chime not to function properly with the doorbell. For a brief overview of the wiring

# Mechanical Chime Wiring Diagram

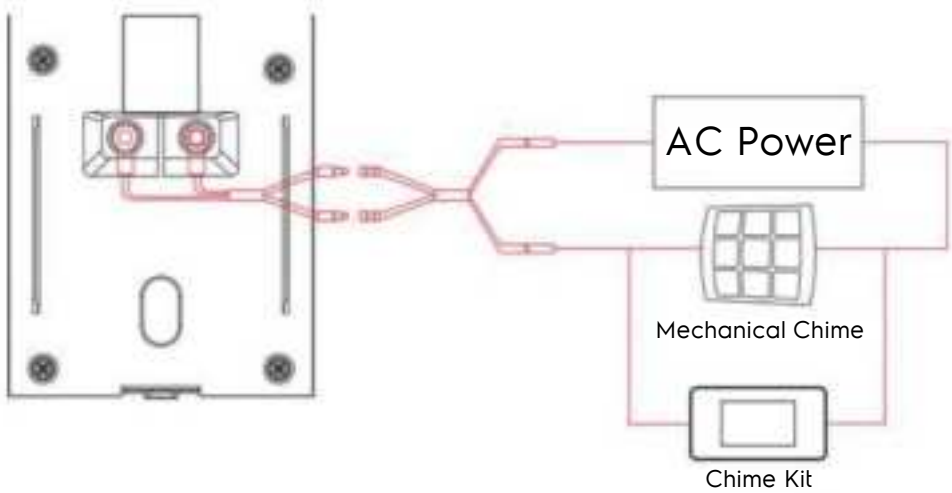

# Electronic Chime Wiring Diagram

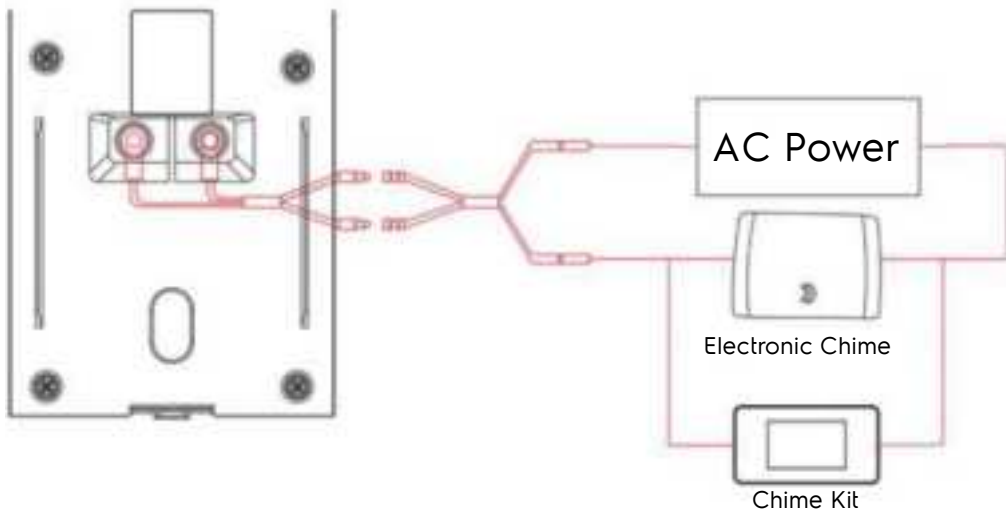

# Wireless Chime Wiring Diagram

For systems using wireless chimes the included Chime Kit is not required. Please see diagrams listed below for more details.

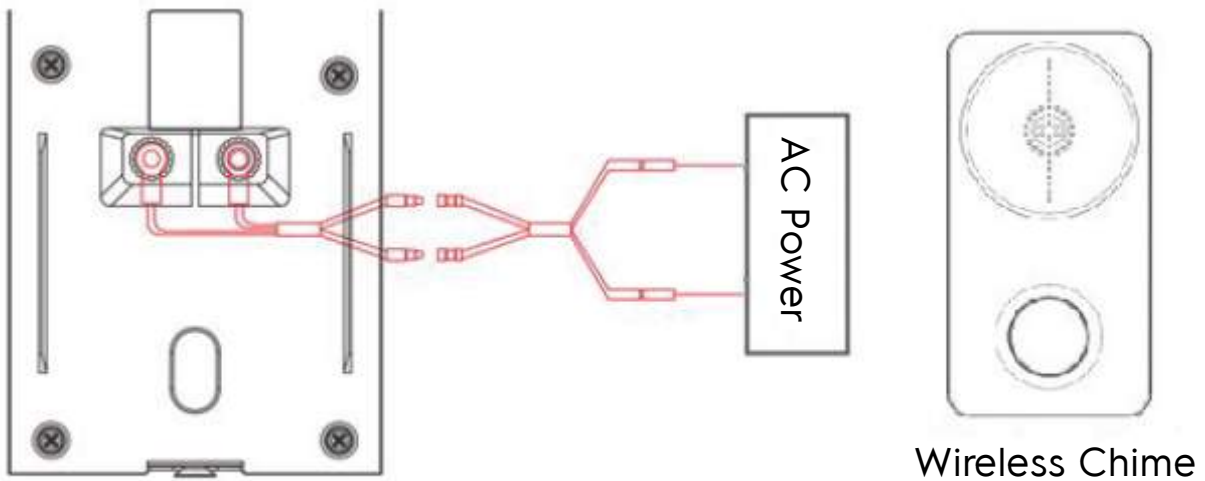

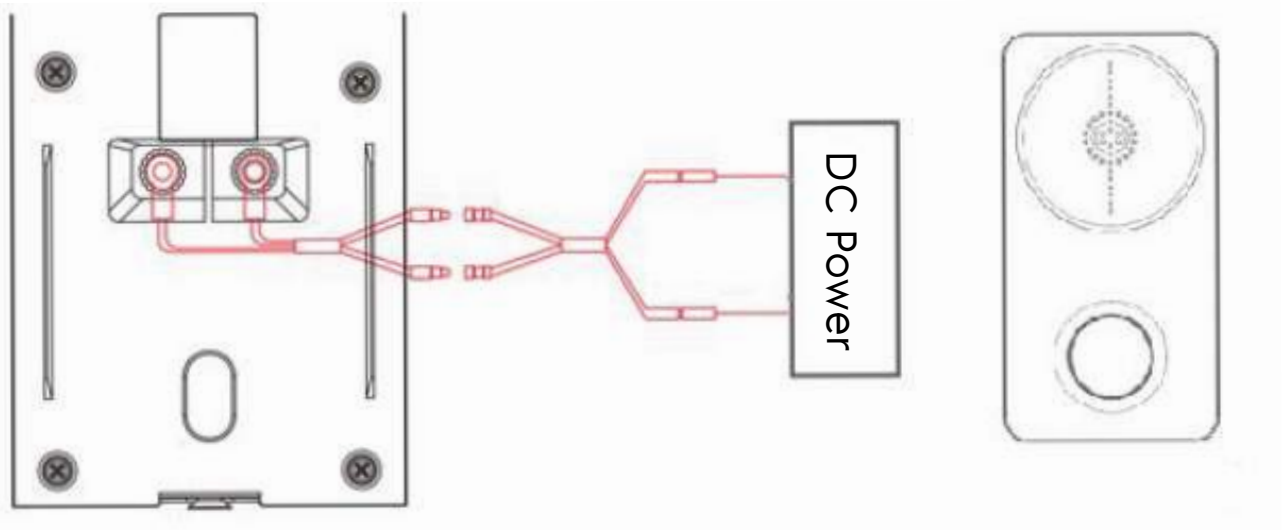

## Bottom

The bottom of the device houses a screw hole and a security screw. These are used to secure the device to the included mounting bracket during physical installation.

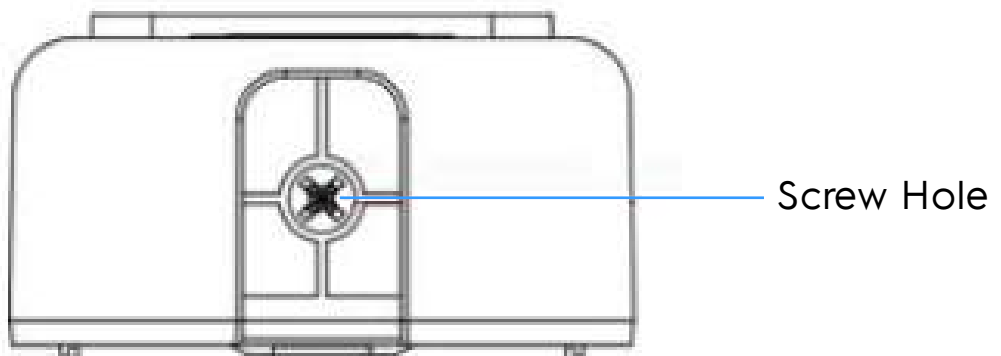



# Physical Installation

Before physically installation, please ensure the proper voltage is present in the area you are installing the device. The voltage at the install sight should range between **16V-24V AC** to function. If proper voltage is not available, it is highly recommended to contact a licensed electrician to complete the physical installation of your device.

The Amcrest Wi-Fi video doorbell **does not require a chime to function as long as adequate voltage is being applied to the device**. Please note, the Amcrest WiFi doorbell also does not require any special resistors and/or diodes to function. For more information on how to install your device, please refer to the information below.

## Installing the Chime Kit

The Chime Kit, also known as a power kit, allows the doorbell to sync with your home's existing chime system. If you do not have a chime system, the chime kit is not necessary and you can proceed to the physical installation of your doorbell.

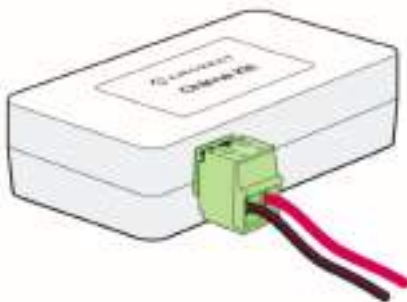

## Connect the Wire Harness

If the wire harness does not come preinstalled with the included wiring. Use a precision screwdriver to open the terminals on top of the connector and insert the wiring into the ports. The red and black wires can be placed in any position inside the connector, and tighten the screws to secure.

## Turn the Circuit Breaker Off

Since we will be working with electrical wiring, make sure to shut off the power to your doorbell at the electrical breakers of your home to ensure no power is flowing through the internal doorbell system.



## Remove the Cover for Your Chime

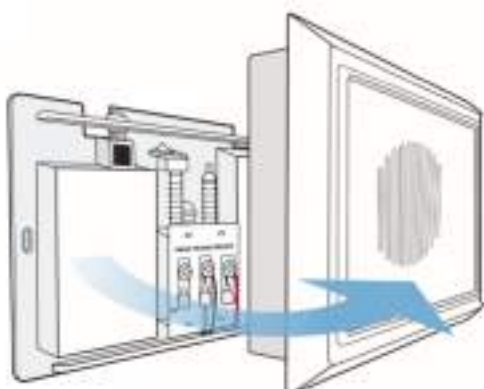

Your existing chime may look different depending on if you have a digital or mechanical chime.



**NOTE:** A Chime Kit is only needed for systems with mechanical or electrical chimes.

## Locate and Loosen the Screws on your Chime

Using the included screwdriver, loosen the screws labeled "FRONT" & "TRANS".

**Note:** Be careful not to detach or remove the existing wiring.

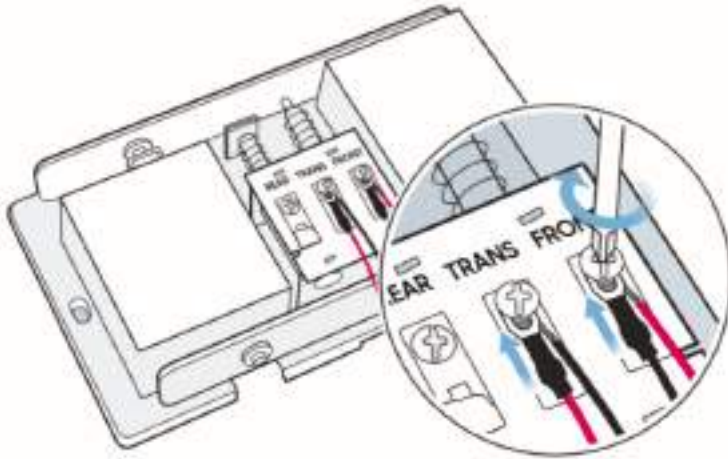

## Connecting the Chime Kit

Slide the connecting wires from the Amcrest Chime Kit underneath the screws, then retighten the screws. It doesn't matter which wires connect to which terminal.

## Replace the Chime Cover

Secure the Amcrest Chime Kit using the included adhesive. If you are using a mechanical chime, ensure any excess wiring is clear of all moving parts.

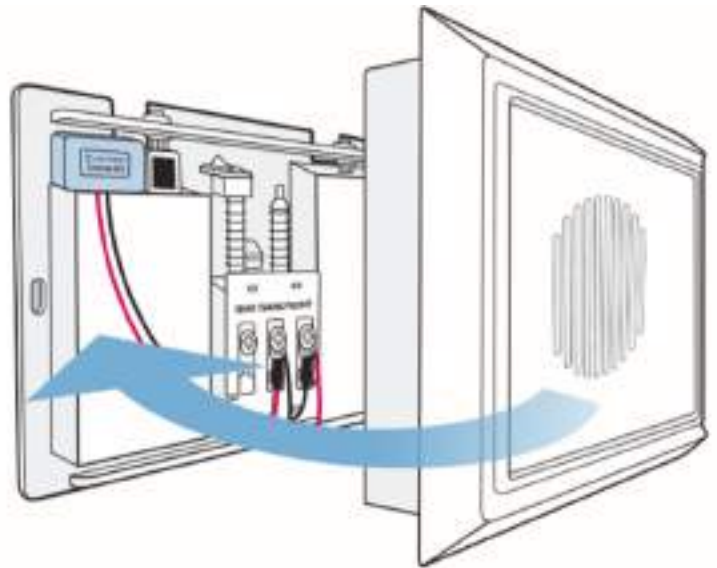

# Installing the Wi-Fi Doorbell

Everything you need for the installation of your Amcrest Wi-Fi doorbell is included in the box, however, a 15/64 masonry drill bit may be required if installing the device on concrete, stucco or brick.

## Remove the Faceplate and Bracket

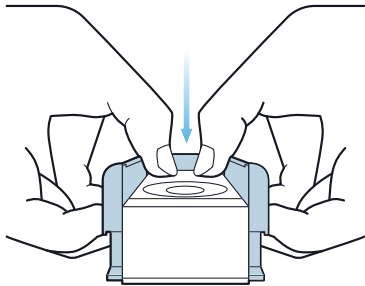

1. Place your fingers in the indentations on the sides of the doorbell, simultaneously pull away and push the faceplate out.

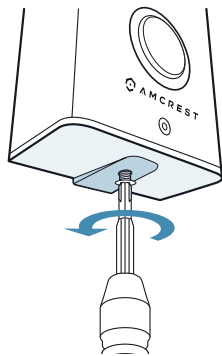

2. Use the included Philips head screwdriver to remove the bracket screw from the doorbell.

## Installing the Mounting Bracket

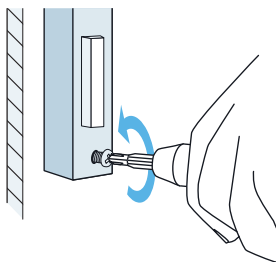

1. Remove your existing doorbell from the wall and disconnect the wires. These are the wires we will be using to install your new Amcrest Wi-Fi Doorbell.

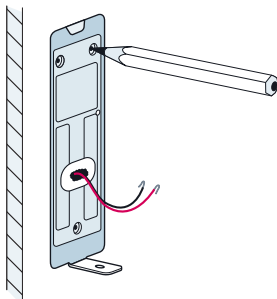

2. Place the doorbell bracket to fit your existing doorbell wiring. Then mark the drill holes with a marker.

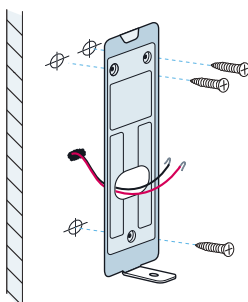

3. For Wood, Drywall or Soft Surfaces: Secure the doorbell bracket to the mounting surface using the included screwdriver and mounting screws.

For Concrete, Stucco or Brick: Using your previously marked holes as a guide, drill holes into the mounting surface using a 15/64 masonry drill bit. Then, insert wall anchors and secure the mounting brackets using the included mounting screws.

## Connect Doorbell to Existing Wiring

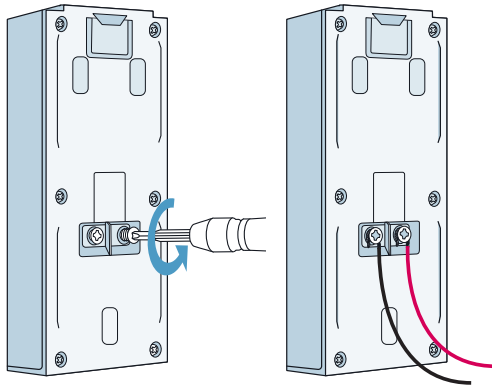

Loosen the terminal screws located on the back of your Wi-Fi Doorbell using the included Phillips head screwdriver. Place your existing doorbell wiring underneath the terminal screws, then re-tighten the terminal screws to secure the wires.

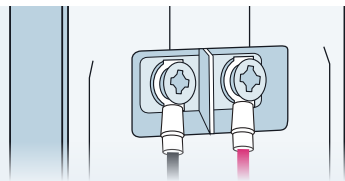

**NOTE** If your existing doorbell wiring is too short, use the included extra wires and wire nuts to extend your wiring. Remove the terminal screws completely then thread the screws through the extra wire.

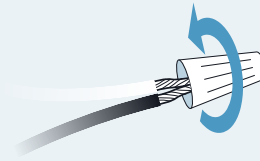

**NOTE** To attach the wires, align the ends of the two wires, place the wire nut over the exposed wiring and twist the wire nut clockwise to tighten.

## Mounting the Doorbell

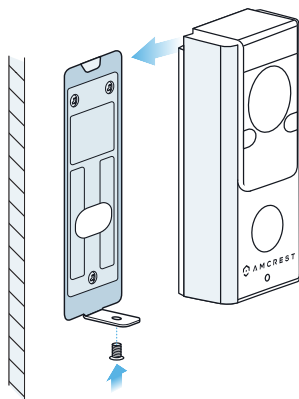

Feed the wiring back into the wall. Then, secure the doorbell to the mounting bracket using the included screwdriver.

**NOTE** Be sure to secure the the doorbell correctly to the bracket lip, located at the top at the mounting bracket.

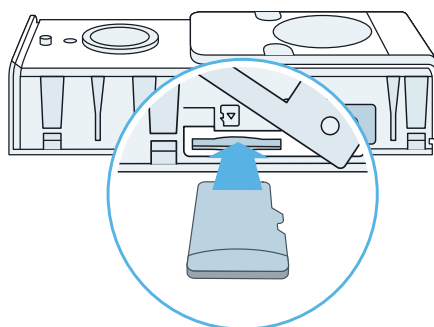

### Inserting a MicroSD Card (Optional)

On the side of the device locate the MicroSD card slot. Raise the MicroSD card flap and insert the MicroSD card, gold pins down. Secure the flap back to the doorbell.



Supports 128GB MicroSD Card (Class 10 or Higher)

## Turn the Breaker Back On

The physical installation is now complete. Turn your breaker back on and allow the doorbell to power up. It may take the doorbell up to 2 minutes to fully power up.



Amcrest  
Smart Home

### Now it's time to setup the Amcrest Smart Home App.

To connect your Amcrest Wi-Fi doorbell to your Android or iOS mobile device, download the Amcrest Smart Home app and follow the instructions in the app setup.



## Amcrest Smart Home App Setup

The Amcrest Smart Home app connects your Amcrest Wi-Fi doorbell to your Android or iOS mobile device ensuring you are always connected to what matters most.



To get the app, search for "Amcrest Smart Home" in the Google Play or App Store and download.

### Connecting to the App

Open the Amcrest Smart Home app and tap on "Register" to register an account. Log in and click on "Add Device".





### Scan the QR Code

Scan the QR Code on the back of the doorbell or manually enter the serial number for the device by tapping "Manually enter S/N". The serial number can be found on the serial tag on the back of the doorbell or on the side panel of the doorbell box.



### Connect to the Hotspot

Remove the protective plastic casing from the doorbell and press the reset/config button on the side of the doorbell to enable the hotspot for your device. If there is a blue spinning light on the front of the device, it means that the device hotspot is properly turned on. Tap "Next" to continue. Tap "Yes" to verify the hotspot has been properly enabled.



### Set a Password

Type in a password you would like to use and confirm it. Please use a combination of letters, numbers, and symbols between 8 - 32 characters long when setting up a password.

Tap "OK" to continue.



### Choose Your Wi-Fi Network

Select your Wi-Fi network from the Wi-Fi network list. Enter the password for your home Wi-Fi network. If you would like to save this password to the app, tap on "Save Password"

Tap "Connect" to continue.



### Connect to Your Device

Once connected, the LED indicator on the front of the doorbell will turn solid blue. This may take a few moments but if the LED indicator continues to spin or the device is reporting "Wi-Fi password is incorrect". Tap on "Start Over" to try again.

Tap "Next" to continue



### Name Your Device

Rename your doorbell. A few examples are provided such as; Front Door, Back Door, Office, and can be selected if needed. After you have finished naming your device, tap on the save (F) icon to continue.

**Note:** If you have chosen the wrong Wi-Fi network and would like to select another Wi-Fi network for the doorbell to connect with, tap on "Select other network".



### Chime Settings

Amcrest doorbells can only link up to one electronic or one mechanical chime. For more information on linking a chime, refer to "Linking a Chime".

Tap **"Next"** to continue.

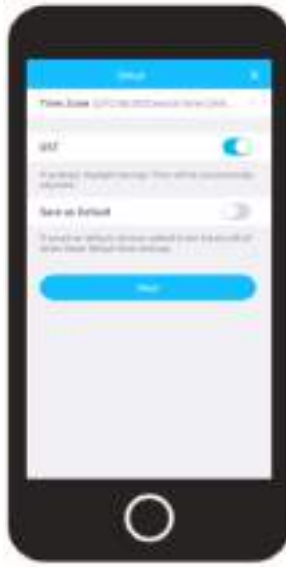

### Set the Time and Date

Set "Time Zone" to your current time zone and set **"DST"** (Daylight Savings Time) settings if applicable.

Tap **"Next"** to continue.

**\*\*Tap Start Live View to view the live feed.**



### Live View

The main screen will be your devices menu. This is a menu that will display all connected devices and well as quick access to certain settings for your doorbell.

## Live View



#### SETTINGS

Provides access to settings such as motion detection, doorbell firmware updates, etc.



#### MULTIVIEW

View multiple devices on one screen.



#### TALK

Enables the microphone for two way communication



#### LISTEN

Enables the speaker for two way communication.



#### PAN/TILT

Only applicable for Pan/Tilt capable devices.



#### FULL SCREEN

View your feed in full screen mode.



#### SD/HD

Set the device to standard or high definition resolution.



#### SNAPSHOT

Manually take a photo.



#### RECORD

Manually record a video.

## Answering the Door



When someone is at the door, you can use these features:



**ACCEPT**

Tap accept to talk to visitors at the door.



**MUTE**

Mute or unmute the call.



**HANG UP**

Hang up to end or ignore the call.

## Linking a Chime

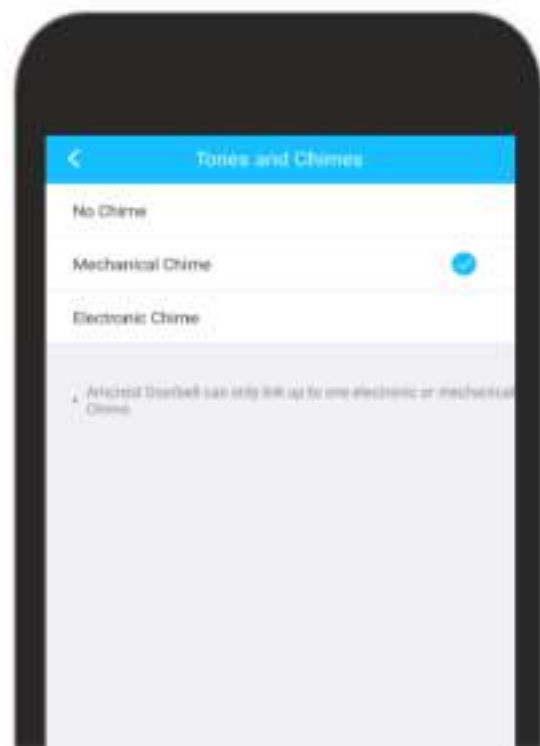

This is only necessary if you have an existing chime system and have installed the chime kit. If you do not link the chime to the Amcrest Smart Home app, the doorbell will not link with your chime. To link your doorbell to the chime, open the Amcrest Smart Home app and access your device. Tap on the settings icon (⚙️) and tap on "Amcrest Chimes". In the Amcrest Chimes menu, tap on "Link Electronic/Mechanical Chime".

If you are linking the doorbell to a mechanical chime, tap on "Mechanical Chime". If you are connecting to an electronic or digital chime, tap on "Electronic Chime". Tap on the back arrow to exit.



# Multiview

The multiview option is used to view up to 4 devices simultaneously on the live view screen. To access the multiview menu, tap on the Multiview icon located on the live view interface.

		
<p><b>Add a Device</b> Tap on the ( + ) icon to begin adding optional devices to the live view screen.</p>	<p><b>Select your Device</b> Select your device from the optional channels menu. The interface can view up to 4 devices simultaneously. Once added, a blue "Added" display will be shown next to the newly added device.</p>	<p><b>View Your Devices</b> The added devices can now be viewed simultaneously on the live view screen. To exit multiview, tap on the "Single View" option located on the live view interface.</p>

# Talk/Listen

The talk button allows you to activate the microphone on your smartphone device to talk to your device. The talk button can be used together with the listen button to enable two way audio.



Tap the talk button to activate the microphone on your smartphone. You will hear audio from the device on your smartphone.



Tap on the listen button to activate the speaker on your device. This will enable two way audio when activated with the talk button.

## Full Screen

The fullscreen option allows you to view a full screen view of the live feed from your device. When in full screen mode, tap the live view screen to access the live view features for your device. To exit full screen mode, tap on the back arrow (<) to revert the live feed back to its original format.



## HD/SD

The HD/SD button will set the live feed for your device in standard definition or high definition. High definition will set your device to the highest possible resolution, standard definition will revert the live view resolution to its original factory resolution.









Tap the HD button to set the live view of your device to high definition.

Tap on the SD button to revert the live view of your device back to standard definition.



# Manual Snapshot/Record

The snapshot and record button allow you to manually take snapshots or video of the live feed. All manual snapshots and videos will be stored in the My Saved Files folder located in the Account section of the Amcrest Smart Home app.





		
<p><b>Take a Snapshot</b></p> <p>Tap on the Snapshot button to manually take a snapshot of the live view screen.</p>	<p><b>My Saved Files</b></p> <p>To view the snapshot, use the back arrow ( &lt; ) to access the devices menu. Tap on Account and access the <b>My Saved Files</b> folder.</p>	<p><b>View you Photo</b></p> <p>Tap on the snapshot folder icon ( 📁 ) to access snapshots. Tap on the photo you want to view in the interface.</p>
		
<p><b>Take a Video</b></p> <p>Tap on the Record button to manually take a video of the live view screen.</p> <p>To stop the recording, tap the record button again.</p>	<p><b>My Saved Files</b></p> <p>To view the snapshot, use the back arrow ( &lt; ) to access the devices menu. Tap on Account and access the <b>My Saved Files</b> folder.</p>	<p><b>View you Video</b></p> <p>The interface will default to the video folder. Tap on the file you would like to view in the interface.</p>



# Amcrest Smart Home Cloud

The Amcrest Smart Home Cloud is an optional premium cloud storage service that offers a wide range of storage options for cloud users who wish to have secure cloud based options for their recordings. This is different from Amcrest Cloud service as the Amcrest Smart Home cloud is exclusive to Amcrest Smart Home devices and will not be compatible with other traditional or legacy Amcrest IP cameras or devices.

All cloud plans are available for purchase in the Amcrest Smart Home app once an account and device has been properly setup. An Amcrest Smart Home cloud subscription will be active for exactly 30 days starting from the minute you subscribed and are based off motion detection recordings only. To keep a cloud subscription active it is recommended to select "Auto Renewal" when checking out. For more information on how to activate an Amcrest Smart Home Cloud storage plan, please refer to the information provided below.

			
<p><b>Access Your Account</b></p> <p>Log into your Amcrest Smart Home app and select the device you wish to activate.</p> <p>On the live view screen tap on <b>Cloud Recordings</b>.</p>	<p><b>Activate Cloud Storage</b></p> <p>Tap on <b>Activate Cloud Storage</b>.</p>	<p><b>Choose Your Plan</b></p> <p>Select a Cloud Storage plan from the list of cloud plans and tap <b>Buy</b>.</p>	<p><b>View Cloud Plan</b></p> <p>Enter your billing information into the billing form. All plans will require a credit card to process the request.</p> <p>After you have purchased your Amcrest Smart Home cloud plan you will be able to store and view your recordings all from the Cloud Recordings menu.</p>

**Note:** Any plan changes made to your account will only take place at the end of your current billing cycle.

# Amcrest Smart Home Cloud Plans Explained

Amcrest offers a wide range of options for cloud users who wish to have secure cloud based options for their recordings. These include our free 1 year cloud plan which offers 3 days of motion detection storage with a 12 second record time and 7 minute cool down to a 30 day motion detection storage plan that offers unlimited recorded as well as no cool down.

All cloud plans are available for purchase in the Amcrest Smart Home app once an account and device has been properly setup. An Amcrest Smart Home cloud subscription will be active for exactly 30 days starting from the minute you subscribed. To keep a cloud subscription active it is recommended to select "Auto Renewal" when checking out.

## What is Cloud Storage Time?

Every Amcrest Smart Home cloud subscription is based on a 30 day cycle. Different plan times (7 day, 14 days, etc.) represent how long new recordings are stored and accessed from the cloud. For example, if you select a 7 day storage plan, you will only have access to the last 7 days of recordings. Any recordings from 8 days ago will have been automatically over-written and therefore inaccessible.

## How Does the 1 Year Free Cloud Plan Work?

Amcrest Smart Home offers a 1 year free trial plan which allows you to try the Amcrest Smart Home cloud free for 1 year. The free trial plan offers, 3 days of motion detection storage with 12 seconds of record time per event as well as a 7 minute cool down in between events. A credit card is still required for the free trial plan as after 1 year the plan will expire which will default your account to a paid, 3 day motion detection storage plan. The 3 day motion recording plan cost is \$1.99 per month and offers the same 12 second record time and 7 second cool down.

## Other Amcrest Smart Home Cloud Storage Options

On top of the 1 year free trial plan, Amcrest Smart Home also offers several paid storage options as well.

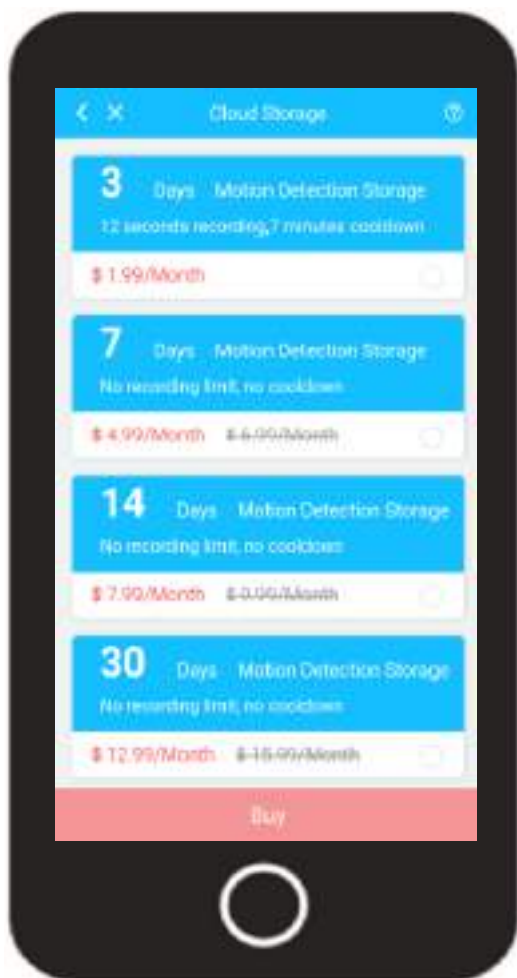

**3 Days Motion Detection Storage** - This is the default plan that is placed on your account if you have signed up for a free 1 year cloud storage plan and it has expired. It is \$1.99/month and offers 3 days of cloud storage with a 12 second record time and 7 minute cool down in between recordings.

**7 Days Motion Detection Storage** - This is a cloud storage plan that will store motion recordings for 7 days. It is \$4.99/month and offers no recording limits or cool down periods.





**14 Days Motion Detection Storage** - This is a cloud storage plan that will store motion recordings for 14 days. It is \$7.99/month and offers no recording limits or cool down periods.

**30 Days Motion Detection Storage** - This is a cloud storage plan that will store motion recordings for 30 days. It is \$12.99/month and offers no recording limits or cool down periods.

## Downloading Recordings

Due to the current capabilities of the app recordings can only be downloaded via the Cloud Recordings download interface. All recordings retained on a microSD card will have to be downloaded via a microSD card adapter (sold separately) on a computer. For more information on microSD card recordings, please refer to the microSD card section of this manual.

## Playback/Download Cloud Recordings

			
<p><b>Access Your Account</b></p> <p>Log into your Amcrest Smart Home app and select the device you wish to activate.</p> <p>On the live view screen tap on <b>Cloud Recordings</b>.</p>	<p><b>Access File List</b></p> <p>The file list will display all cloud recordings. to playback a cloud recording, select the clip from the time line. Tap the date to choose recordings on different dates.</p> <p>Tap on the File List icon (☰) located in the Cloud playback interface.</p>	<p><b>Choose Your Clip</b></p> <p>Select the recording you wish to download from the file list.</p>	<p><b>Download</b></p> <p>Tap the download icon located at the bottom of the menu (↓). The recording will begin to download to your smartphone.</p> <p>A blue check mark (✔) will appear next to the download icon once the recording has finished downloading.</p>

**Note:** You can also share your recordings directly to other services on your smartphone via the share icon (📎) located in the middle of the download menu.

## Changing Cloud Plans

Any changes made to your current Amcrest Smart Home cloud plan will take effect on the next billing cycle. Every Amcrest Smart Home cloud subscription is based on a 30 day cycle. All Amcrest Smart Home Cloud plan changes are made via the Amcrest Smart Home app For more information on how to change your Amcrest Smart Home Cloud plan, please refer to the information provided.



### Access Your Account

Open the Amcrest Smart Home app and log into your account.

Tap on the **Account** tab.

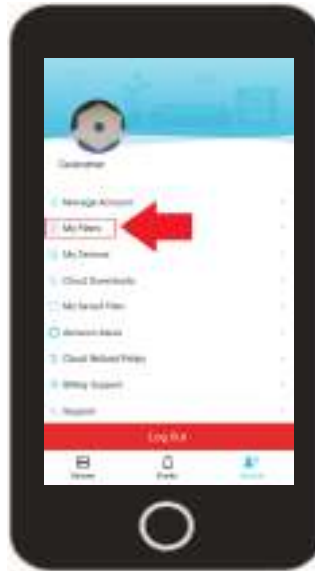

### Access Plan Details

Tap on **My Plans**.

**Note:** The **My Plans** menu will display all past and present Amcrest Smart Home Cloud plans, unpaid, paid as well as cancelled plans. You can filter this via the **"Unpaid"**, **"Paid"**, and **"Cancelled"** tabs.



### Change Current Plan

Select your current plan from the **My Plans** menu.

Then tap on **Change Plan**.



### Update Cloud Plan

Read the provided information on the screen and tap **"Change Plan"** to continue.

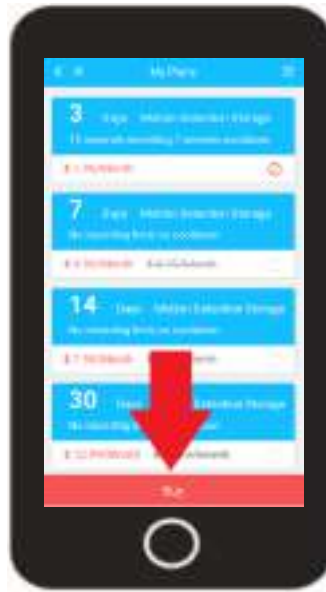

### Choose a New Plan

Select which plan you would like to change to from the Amcrest Smart Home cloud plans provided. Tap **Buy** to continue.



### Confirm Payment

Choose whether you would like to auto renew your payment. Tap **Confirm Payment** to continue.

**Note:** Enter your name, and billing information into the app. This will be the billing information used for the new plan you have selected. Tap **Pay** to complete the process.



# MicroSD Card Recordings

This device is capable of providing local storage via an external microSD card (sold separately). Please ensure you are using a class 10 or above microSD card that does not exceed the storage limitation of your device. The microSD card must be formatted to FAT32. This may have to be done manually as most programs do not format to this allocation automatically.

When a microSD card is inserted into the device, all motion based recordings will be stored to it. Additionally, if you have a Amcrest Smart Home Cloud account, recordings will be stored both on the cloud and microSD card.

## Playback MicroSD Card Recordings

		
<p><b>Access MicroSD Menu</b></p> <p>Log into your account in the app and select your device.</p> <p>On the live view screen, tap on the "<b>MicroSD Card</b>" menu located at the bottom right of the screen.</p>	<p><b>Select Your Recording</b></p> <p>In the MicroSD card menu you will notice a list of recordings. Recordings can be accessed and viewed based on the date the motion occurred and can be found by tapping on the calendar menu in the app.</p> <p>Tap on a file to view the recording.</p>	<p><b>Viewing a Recording</b></p> <p>All motion detection recordings will occur back to back in the interface which allows the device to capture all events without the use of a cool down period.</p>

**Note:** Recordings stored on a microSD card cannot be downloaded to your smartphone via the app. To download the recordings, remove the microSD card from the device and use a SD card adapter to view them on a computer.



The settings menu for your device allows you to configure specific settings such as device information, motion detection, time zone, Wi-Fi and other related settings. All settings are based on the capabilities of the device and may differ between certain models. Please refer to the information below for more information on the settings available for your device.

## Accessing the Settings Menu

The settings menu for your device can be accessed via the live view menu. Tap on the settings icon (  ) to display the settings menu. The settings menu for your device is displayed below.

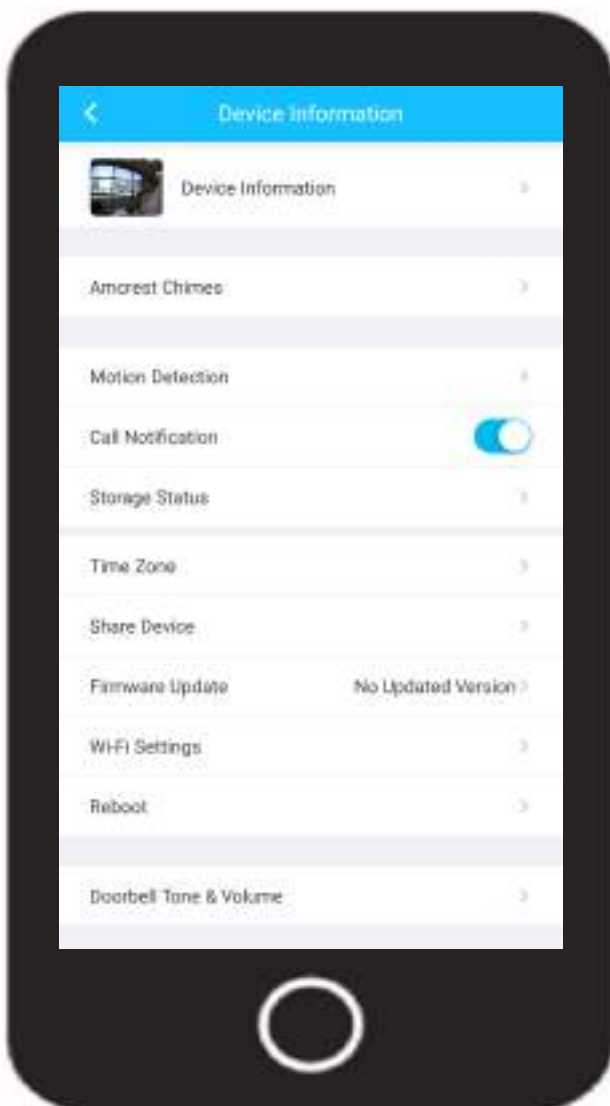

**Device Information** - This menu allows you to update the thumbnail image, name, and password for your device. The model number, serial number and other useful information can be accessed via this menu.

**Amcrest Chimes** - This menu allows you to link a digital or mechanical chime to your device. This process should have been completed during initial setup, however, if a new chime is implemented in your current doorbell system this option is useful.

**Motion Detection** - This menu allows you to customize, adjust, and set motion detection schedules for your device. When motion detection is enabled your device will record video whenever motion is detected.

**Call Notification** - When enabled, you will receive a push notification when someone rings the doorbell.

**Storage Status** - Displays any current cloud or microSD card storage options applicable for your device. This option also allows you to format a microSD card right from your device.

**Time Zone** - This menu allows you to adjust and set any time zone related information for your device. Enable DST (daylight savings time) settings for your device if needed.

**Share Device** - This menu allows you to share your device with other people with established Amcrest Smart Home accounts. You can share up to a max of 6 people.

**Firmware Update** - This menu allows you to update the firmware for your device. If a firmware update is available, a red dot will be displayed in this field.

**Wi-Fi Settings** - This menu allows you to change Wi-Fi networks for your device.





**Reboot** - Allows you to reboot your device.

**Doorbell Tone & Volume** - This menu allows you to adjust the chime volume and well as speaker volume of the doorbell. You can select from 3 default tones as well for your doorbell.

**Delete Device** - This option unbounds your device from your Amcrest Smart Home account.

## Device Information

This menu allows you to update the thumbnail image, name, and password for your device. The model number, serial number and other useful information can be accessed via this menu.

		
<p>Tap on <b>Device Thumbnail</b> to update the thumbnail image for your device.</p> <p>The thumbnail can be default, a manually taken snapshot, or uploaded from your smart-phone.</p>	<p>Tap on Device Name to edit the name of your device. Tap on the Save icon (  ) when finished. To exit, tap on the back arrow ( &lt; ) to exit the interface.</p>	<p>Tap on Password to modify the password for your device. This is not the password for your Amcrest Smart Home account, it is the password to access your device.</p> <p>Tap on the Save icon (  ) when finished. To exit, tap on the back arrow ( &lt; ) to exit the interface.</p>

## Amcrest Chimes

This menu allows you to link a digital or mechanical chime to your device. This process should have been completed during initial setup, however, if a new chime is implemented in your current doorbell system this option is useful.

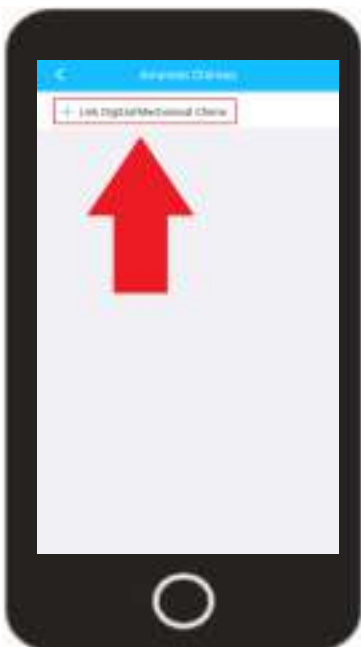

The Amcrest Wi-Fi doorbell should be linked to a chime during initial installation however, if a new chime is introduced to the system it can be manually configured using the Amcrest Chimes menu.

To configure the chime, tap on “**+Link Digital/Mechanical Chime**” and select whether the chime is a mechanical or digital chime. As a precaution, the doorbell can only link up to one digital or mechanical chime at a time.



# Motion Detection Overview

Amcrest Smart Home devices allow you to view motion detection recordings locally, using a microSD card (sold separately) or via Amcrest Smart Home cloud which is a cloud based service where you can remotely view and store motion detection recordings.

By default, motion detection is automatically enabled on all Amcrest Smart Home devices. All motion detection settings are adjustable using the Amcrest Smart Home app. Having motion detection enabled allows your device to record video clips whenever motion is detected. If you are accessing recordings locally using a microSD card, a microSD card must be inserted in your device before use.

**Note:** If storing motion detection events locally on a microSD card, please make sure the microSD card is class 10 or above and properly formatted to FAT32. The doorbell is compatible up to 128GB.





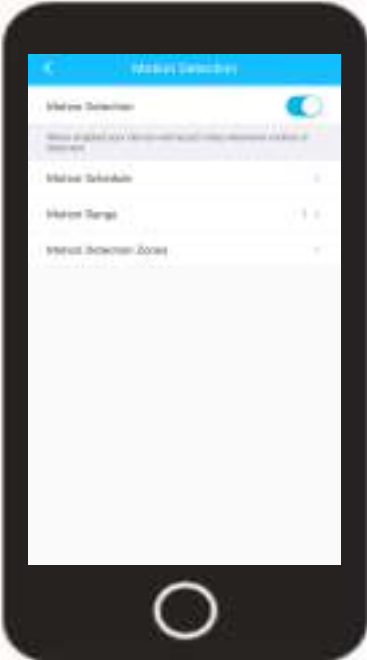

## Motion Detection Settings

All motion detection settings for your device will be adjusted through the Amcrest Smart Home app. The Amcrest Wi-Fi doorbell has a maximum motion detection distance of up to 16 feet, day or night. Its built-in PIR sensor allows the camera to cover more distance and provides more accuracy when detecting motion. For more information on accessing the motion detection settings, please refer to the information provided below:



	
<p>To access the motion detection settings, open the Amcrest Smart Home app and access the live view screen for your device.</p> <p>Tap on the settings icon (⚙️) and select Motion Detection.</p>	<p>The motion detection settings for your device will be displayed in this menu which will allow you to adjust and control motion settings such as, motion schedules, PIR ranges, and motion detection zones.</p>

# Motion Detection Schedules

A motion schedule allows you to set the device to begin recording motion detection events at a designated time. This is useful if you would like the device to only start detecting motion during specific times of the day. If you would like the device to record motion 24/7 you can leave the schedule as default. However, for more information on how to set a motion schedule, please refer to the information provided below.

		
<p>Log into your Amcrest Smart Home app and access the motion detection menu.</p> <p>Tap on <b>Motion Schedule</b>.</p>	<p>Tap on the day of the week you wish to modify. If you are setting a schedule for multiple days of the week this can be done later in the interface.</p>	<p>Tap on <b>"Add Schedule"</b>.</p>
		
<p>Tap on <b>"Start Time"</b> and use the scroll option to select a time you want the motion schedule to start.</p>	<p>Tap on <b>"End Time"</b> and use the scroll option to select a time you want the motion schedule to stop. Tap on the</p>	<p>Tap on <b>"Repeat"</b> to choose which days of the week you would like the motion schedule to apply.</p>

**Note:** Motion schedules cannot overlap.

	
<p>A blue check mark will be displayed next to the active days.</p> <p>Tap the back arrow ( &lt; ) to exit.</p>	<p>Tap on the "Save" button to save your motion schedule. The motion schedule is now applied to your device.</p> <p>Tap the back arrow ( &lt; ) to exit.</p>

## Motion Sensitivity

Motion sensitivity allows you to adjust how sensitive the motion detection will be for your camera. This is based off a minimum and maximum value ranging between 1, having the least amount of sensitivity, and 6 being the max. The default sensitivity level will be 3. This is the optimal sensitivity level as it can reduce the level of false motion events while still providing the most accurate detection of your events.



The lower the sensitivity value is on your camera the more activity the sensors need to retain an event or send a push notification. It is highly recommended to leave the sensitivity at 3 however, if you make any adjustments be sure to tap on the blue check mark (■) to save the motion sensitivity setting.

## Setting Motion Detection Zones

Setting motion detection zones allows you to customize activity zones for motion detection areas. This helps to block out and avoid false motion events and is useful for blocking out areas such as trees, bushes, or other areas to avoid





To set a motion detection zone, tap on "Clear Zone". Use your finger to highlight the area(s) on the screen that you would like to block motion detection events. Tap on "Save Zone" to save the motion detection zone. Tap on the back arrow ( < ) to exit.

## Activating Smart Notifications

Smart notifications are push notifications that are sent to your phone which let you know a motion or other event has been detected. These actions can range from a motion being detected by your device by a call coming through from someone using your Amcrest WiFi doorbell.

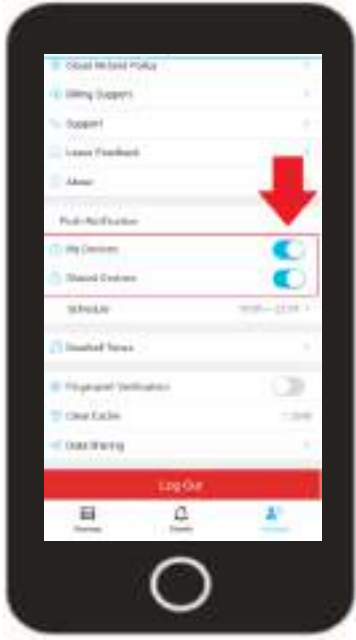
<p>Smart Notifications can be turned on or off using the Amcrest Smart Home app. These settings are account based and not necessarily based per device.</p>	<p>To turn smart notifications on or off, log into your Amcrest Smart app and tap on the <b>Account</b> menu.</p>

	
<p>In the account menu, scroll down to the <b>"Push Notification"</b> menu. You will notice 2 toggle switches, one for your devices and one for shared devices.</p>	<p>Use these toggle switches to turn smart notifications on or off for your devices or for shared devices. If you would like to turn off motion detection events you can based on device in the Devices menu. To turn off motion events per device toggle the "running man" icon ( 🏃 ) to the off position.</p>



## Call Notification

When enabled, you will receive a push notification when someone rings the doorbell. If this function is disabled, the call notification will not come through on your smartphone.

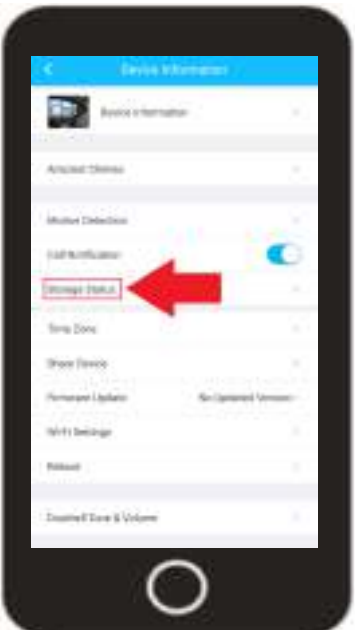

## Storage Status

The storage status menu displays any current cloud or microSD card storage options applicable for your device. This option also allows you view current cloud subscriptions applicable to your device as well as format a microSD card right from your smartphone.

		
<p>To access the Storage Status menu, tap on the settings icon (⚙️) on the live view screen.</p> <p>Tap on the Storage Status option located in the settings menu.</p>	<p>The microSD card storage capacity will be displayed in this menu. If no microSD card is being read by the device the status will be "Disabled"</p> <p>To format the microSD card, tap on <b>"Format Storage Device"</b>.</p>	<p>To access cloud storage details, tap on "Cloud Storage". Then tap on <b>"Active Cloud Service"</b>.</p> <p>This menu allows you to change a cloud plan, update payment information, or cancel a subscription.</p>

## Time Zone

This menu allows you to adjust and set any time zone related information for your device. Enable DST (daylight savings time) settings for your device if needed.



To change the time zone for your device tap on **"Time Zone"** and select your time zone from the provided list.

Tap the back arrow (<) to return to the previous menu





Daylight savings time (DST) should be enabled by default however, if you would like to enable/disable it use the provided **DST** toggle switch.

Tap the Save (💾) icon to save your time zone settings.

## Share Device

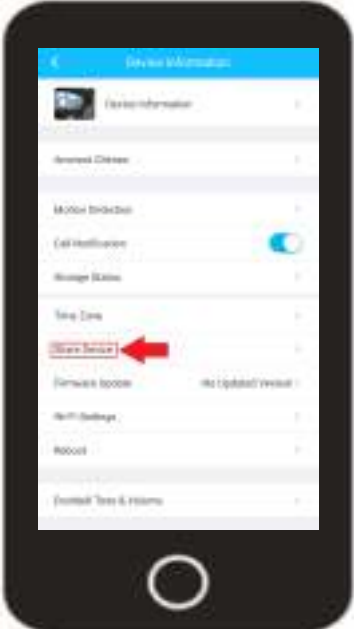

Device sharing allows you to add specific Amcrest Smart Home users to share the live feed of your added device. When you add a shared user, the shared user will have access to your camera and features such as live viewing, recording, playback, and two-way audio.

**Note:** The maximum users allowed on a shared account is 6 users.

		
<p>To access the <b>Share Device</b> menu, tap on the settings icon (⚙️) on the live view screen.</p> <p>Tap on the <b>Share Device</b> option located in the settings menu.</p>	<p>Tap on, "<b>Add a Shared User</b>".</p>	<p>Enter a registered Amcrest Smart Home account email you would like to share your device with. Once you have entered the email press the Save icon (💾).</p> <p>Tap <b>OK</b> to add the shared user.</p>



## Removing a Shared Device

Removing a shared device from your account will revoke sharing permissions for added shared users. You can remove a shared user in the Shared Device menu.

	<p>Access the Shared Device menu and locate the shared user on your device.</p> <p>Tap <b>Remove</b> to remove the shared user.</p>		<p>Tap <b>OK</b> to remove the shared user from your device.</p>
---	---	--	--

## Firmware Update

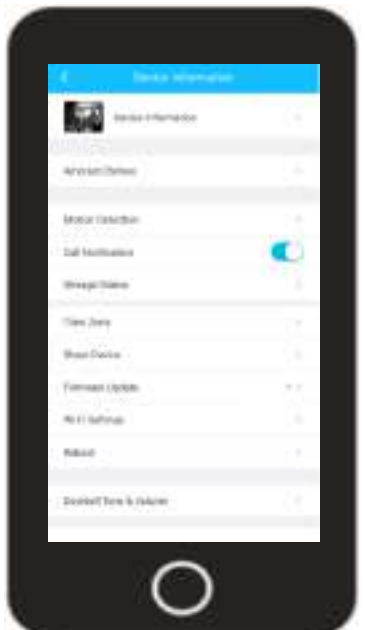
This menu allows you to update the firmware for your device. If a firmware update is available, a red dot will be displayed in this field. It is highly recommended to keep the firmware for your device up to date at all times.

		
<p>To access the <b>Firmware Update</b> option, tap on the settings icon (⚙️) on the live view screen.</p> <p>Locate the <b>Firmware Update</b> option.</p>	<p>If a firmware update is available there will be a red identifier prompting you that a firmware upgrade is ready.</p> <p>Tap on the "<b>Firmware Update</b>" tab to proceed with the update if it is available.</p>	<p>you will notice the current version of firmware that is on your camera, and the latest firmware file that will be downloaded to your camera. To proceed with the update, please click on "<b>Update</b>". Tap "<b>Cloud Upgrade</b>". and allow the device to update.</p>

## Wi-Fi Settings

This menu allows you to change Wi-Fi networks for your device. Please note, this device is not a dual band device, please make sure to connect to a 2.4GHz Wi-Fi network.

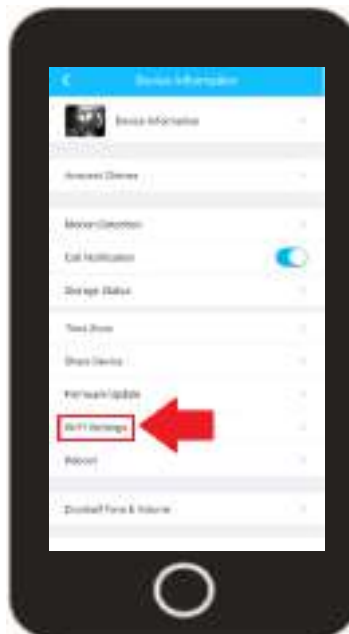

To access the **Wi-Fi Settings** menu, tap on the settings icon (⚙️) on the live view screen.

Tap on the **Wi-Fi Settings** option and select your Wi-Fi network from the Wi-Fi list. Enter the Wi-Fi password for your network and tap the save icon (💾) to save the new Wi-Fi network to your device.

## Reboot

The reboot option allows you to reboot your device from the Amcrest Smart Home app.

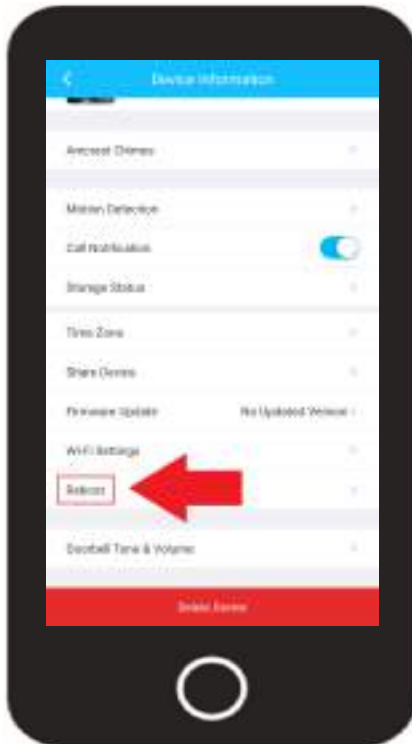

To access the **Reboot** option, tap on the settings icon (⚙️) on the live view screen.

Tap on the **Reboot** option and tap “Yes” to continue. The reboot process will take up to 3 - 5 minutes to complete. Allow the device to reboot before accessing the live feed or other related options.

## Doorbell Tones & Volume

This menu allows you to adjust the chime volume and well as speaker volume of the doorbell. You can select from 3 default tones as well for your doorbell.

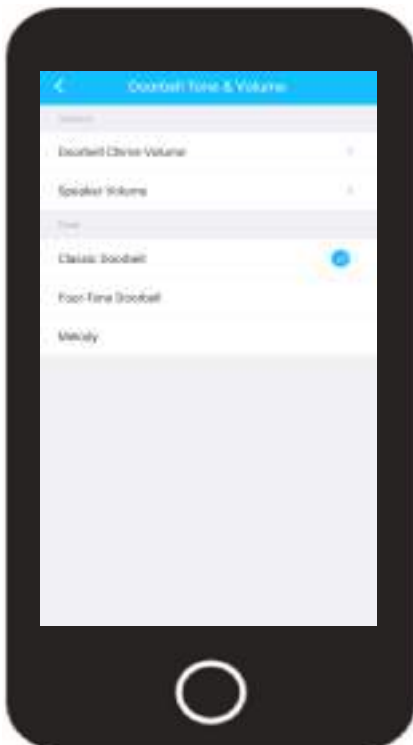

To access the **Doorbell Tones & Volume** menu, tap on the settings icon (⚙️) on the live view screen.

Tap on the **Doorbell Tones & Volume** option. For more details on the information provided in this menu, please refer to the information provided below.

- **Doorbell Chime Volume** - Use this slider to adjust the tone volume on the doorbell.
- **Speaker Volume** - Use this slider to adjust the volume of your voice when using two way audio.
- **Tone** - Allows you to choose between three different tone options. When the call button is pressed, the chosen tone will be heard from the doorbell.

## Delete Device

The delete device option allows you to unbound and remove the device from your Amcrest SmartHome account. This option is useful if performing a factory reset on the device or setting up the device in a new location.

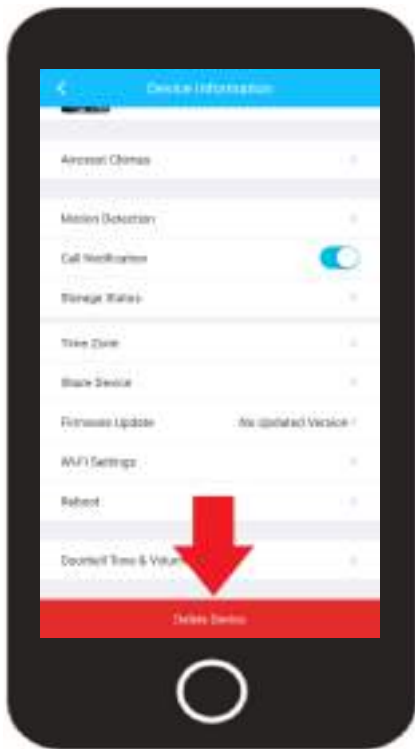

To access the **Delete Device** option for your device, tap on the settings icon (⚙️) on the live view screen.

Scroll down to the bottom of the settings menu and tap on the Delete Device option. A prompt will appear asking if you are sure you would like to delete the device. If any cloud recordings are present on your account for this device you can choose to keep the recordings stored or remove them once the device is deleted.

By default, cloud recordings will be stored after the device is deleted however, you can uncheck this option to delete cloud recordings for this device.

Tap on **Delete** to delete the device from your account.

## How to Perform a Factory Reset

Performing a factory reset on your doorbell will reset the device back to its original default settings. It is highly recommended to delete your device from your Amcrest Smart Home account before performing a factory reset. For more information on how to factory reset your device, please refer to the information provided below.

- To begin, Remove the front face plate and the protective face plate of the doorbell and locate the reset/config button on the side of the device.

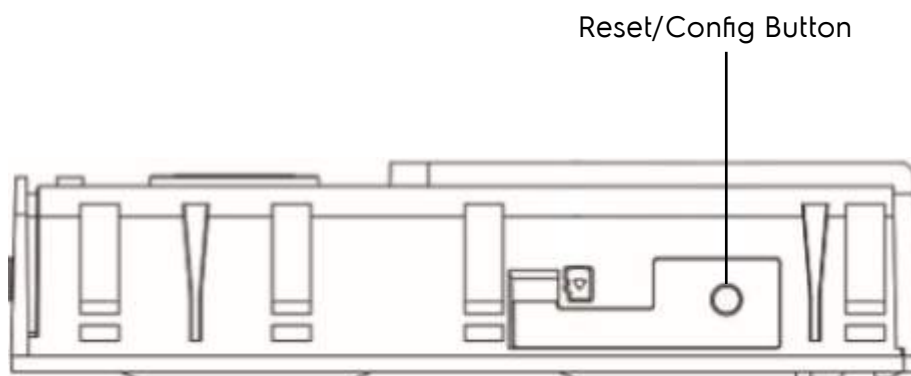

- Press and hold the reset button until the device prompts you that it is hard resetting.
- Let go of the reset button. The LED indicator on the front of the doorbell will begin to flash blue. Allow the device to reset for roughly 1 - 2 minutes,





Your doorbell has now been successfully reset to its original factory settings. The **admin** username and password for the doorbell has been reset to admin.

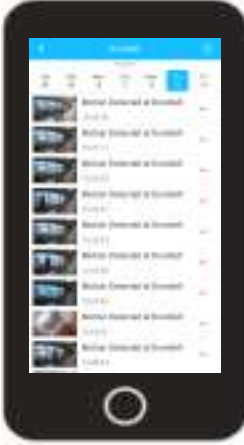

The events menu provides quick access to system and device related security and system alerts. The security alerts menu provides information on how many push notifications were sent, per device, per day and provides a way to view each notification that was sent **within a 7 day period**. The system notification menu retains notifications provided by the developer. This can range from system maintenance messages to firmware update reminders for your device. For more information on the information provided in the events menu, please refer to the information provided below.

## Security Alert

The security alerts menu provides information on how many push notifications were sent, per device, per day and provides a way to view each notification that was sent **within a 7 day period**.

		
<p>To access the events menu, log into your account and tap on the <b>Events</b> tab at the bottom of the screen. Select your device from the interface.</p>	<p>A list of events will be displayed. Use the calendar to select which days worth of events you would like to view.</p>	<p>Tap the play button to play the event. Tap <b>“Go to Live View”</b> to view the live feed. Tap the full screen icon (  ) to view a fullscreen view of the event. Tap the share button (  ) to share the event. Tap the download button (  ) to download the event to your smartphone.</p>

## System Alerts

The system notification menu retains notifications provided by the developer. This can range from system maintenance messages to firmware update reminders for your device.



To access the system alerts menu, access the events menu and tap on **System Alerts**. All system alert information will be displayed in this menu.

Tap on a system alert to view the information provided in the alert.



# Account Menu

The accounts menu allows to view and update general account information as well as customize and adjust specific settings for your device. For more information on the options available in the account menu, please refer to the information provided below.

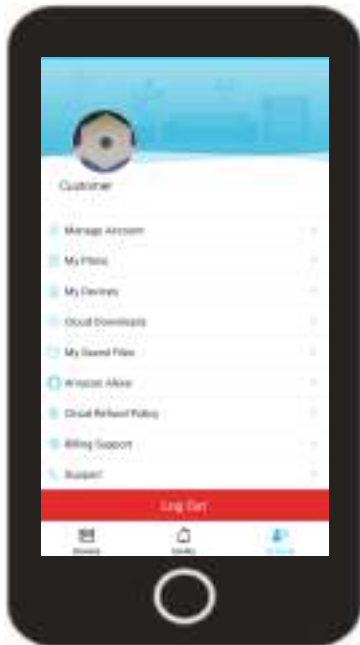

To access the Account menu, open the Amcrest Smart Home app and log into your account. Tap on the Account menu option located at the bottom of the interface.

All account based options for your account will be displayed in this menu. Use your finger to scroll up and down the menu for more options.

<p>The <b>Manage Account</b> menu allows you to edit a profile picture, update the name on your account, password, as well as the Email address used for your account. To exit the manage account menu, tap on the back arrow (&lt;).</p>	<p>The <b>My Plans</b> menu allows you to view all unpaid, paid, and cancelled cloud storage plans transactions associated with your Amcrest Smart Home account. To exit the my plans menu, tap on the back arrow (&lt;).</p>	<p>The <b>My Devices</b> menu allows you to view all connected devices as well as add devices to your Amcrest Smart Home account. To add a device, tap on the (+) icon and follow the in app instructions. Tap on a already connected device to access and adjust device settings.</p>



The **Cloud Downloads** menu allows you to view, delete, or download cloud recordings that were downloaded from the cloud recordings interface. Tap on a clip to view the recording, use the trash can icon to delete it, tap on the download button to download the recording to your mobile device.



The **My Saved Files** menu allows you to view, delete, rename, share, and export manually recorded snapshots or videos. Use the video/snapshot icons to view the manually recorded files. Tap the share icon (📎) or export icon (📁) to export the file.



The **Amazon Alexa** option provides a step by step breakdown on how to add your Amcrest Smart Home device into Alexa. This is possible by implementing the Amcrest Smart Home skill into your device. Please refer to the information in this menu for a detailed description of the process.



Amcrest Smart Home cloud provides a 7-day no questions asked, money back guarantee. There are no refunds after 7 days of the charge date.

For more any inquiry on cloud billing , please visit:

<https://amcrest.com/billing-support>



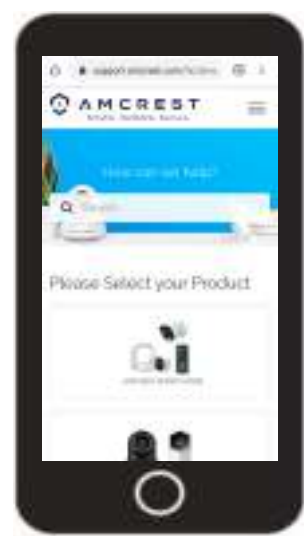

The **Billing Support** tab points you directly to the Amcrest Smart Home Cloud billing form. Use this form for any questions regarding cloud billing or other related billing questions for your Amcrest Smart Home cloud account.



The **Support** tab points you directly to Amcrest knowledge base. Use the knowledge base to access important support articles and online documentation for your device.

To access the support knowledge base directly, please visit:

<https://amcrest.com/support>

	
<p>The <b>Leave Feedback</b> allows you to leave feedback to improve the overall experience of the Amcrest Smart Home app. We take this feedback seriously and are always looking for new ways to improve your experience.</p>	<p>The <b>About tab</b> allows you to view the current app version you are using as well as a link to our privacy policy.</p>

## Push Notifications

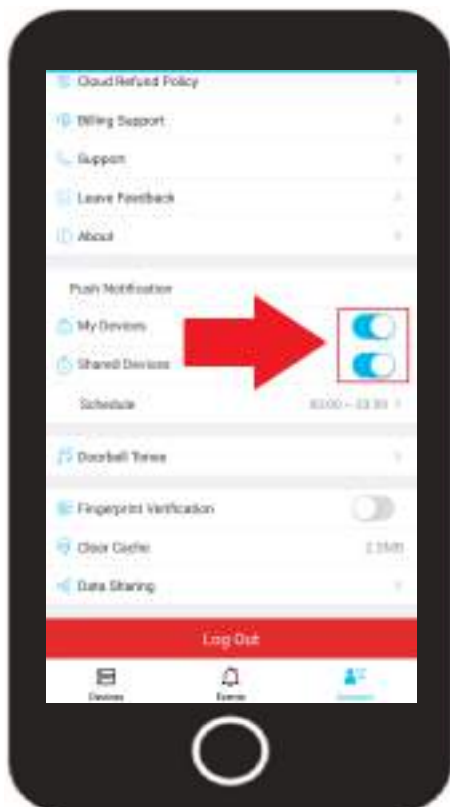

The push notification toggle switches located in the account menu enable and disable push notifications for every device connected to your Amcrest Smart Home account. A push notification schedule can also be setup to allow the app only to send push notifications during a specific time during the day.





The push notification toggle switches will be enabled by default allowing the app to send push notifications to your mobile device once an event has been detected. Please note, the my devices toggle switch will disable or enable push notifications for your account, the shared devices toggle switch will only enable or disable push notifications for any shared users on your Amcrest Smart Home account.

## Setting a Push Notification Schedule

A push notification schedule can be setup which will allow the app only to send push notifications to your device or a shared user's device during a specific time during the day. For more information on how to setup a push notification schedule, please refer to the information provided below.

		
<p>In the account menu, tap on the Schedule option in the Push Notification menu to display the push notification schedule menu.</p>	<p>Tap on <b>"Start Time"</b> and select a time you would like your schedule to start. In this example we are setting it to 0600 (6am).</p>	<p>Tap on <b>"Finish Time"</b> and select a time you would like your schedule to end. In this example we will be setting the end time to be 1700(5pm). Tap on the Save icon (🔒) to save the push notification schedule to your account.</p>

## Doorbell Tones

		
<p>In the account menu, tap on <b>"Doorbell Tones"</b>. This menu allows you to change motion detection and call tones if you have an Amcrest Wi-Fi Video doorbell.</p>	<p>Tap on <b>"Motion Detection"</b> to change the tone of a motion detection notification. There are 4 tones to choose from, select a tone to save it to your account.</p>	<p>Tap on <b>"Call Notification"</b> to change the tone of a call notification. There are 4 tones to choose from, select a tone to save it to your account.</p>

## Fingerprint Verification

The fingerprint verification option allows you to set a fingerprint authentication that will allow you to log into your Amcrest Smart Home app using your fingerprint. Please note, this option will only be applicable to smartphone devices that have fingerprint capabilities.



In the accounts menu, tap on the **"Fingerprint Verification"** toggle switch to enable or disable this feature. A fingerprint must be enabled first on your smartphone before this option can be enabled.

Once you have authenticated your fingerprint on your phone, tap on the fingerprint verification toggle switch and verify your fingerprint to enable this function. Force close the app and then use your fingerprint to log into your Amcrest Smart Home account.

## Clear Cache

The clear cache option allows you to remove cache from the app which helps to increase the efficiency of your overall app experience.



In the account menu, tap on the **"Clear Cache"** option. A prompt will appear asking you if you would like to clear cache.

Tap on **OK** to remove the cache from the app.

## Data Sharing

The data sharing menu allows you enable or disable the ability to share data analytics for your account.

Toggle the **Share Data Analytics** on or off to enable or disable the ability to share data analytics. This option is on by default and is highly recommended to stay on to increase the efficiency of your experience with the app.











# Adding to Blue Iris

Amcrest Smart Home devices such as the Amcrest Wi-Fi Doorbell Camera can connect the Amcrest Smart Home app as well as to Blue Iris. This is possible by obtaining the IP address of your device from your network and adding it directly to the software using RTSP.

The doorbell must be set up first using the Amcrest Smart Home app before adding it into any additional software. Please note: The doorbell and the computer you are using must be on the same network during setup. For more information on how to setup your device to Blue Iris, please refer to the information provided below.

 <p>Open the Blue Iris Software and click on the ( + ) icon to add a camera.</p>	 <p>Enter a Full name and Short name for your doorbell. Make sure to also click on the "Enable audio" check box to enable audio.</p>	 <p>Use the Amcrest IP Config tool to locate the IP address for your doorbell from the network.</p> <p>To download the Amcrest IP config tool, please go to <a href="http://amcrest.com/downloads">amcrest.com/downloads</a></p>
 <p>Enter the IP Address for your camera in the Address field of the Network IP camera configuration menu. Enter the username and password as well you setup for your doorbell in the Amcrest Smart Home app. Click <b>OK</b>.</p>	 <p>Click <b>OK</b>.</p>	 <p>Your doorbell is now ready to be viewed in the Blue Iris software.</p>

**Note:** Leave the Make as Generic/ONVIF and the Model as RTSP H.264/H.265/MJPEG/MPEG4.



# Adding to Amcrest NVR/DVR

Most Amcrest Smart Home devices, excluding Smart Home battery cameras, can connect to both an Amcrest DVR and Amcrest NVR. This is possible by obtaining the IP address of your device from your network and adding it directly into your DVR or NVR. The DVR or NVR must be connected to the same network as the Amcrest Smart Home device for this to work.

The device you are adding must be added to the Amcrest Smart Home app **first** before adding it to your device.

## Adding to An Amcrest NVR

<p>Log into your Amcrest NVR and click on <b>Camera</b>. Then, click on <b>Device Search</b> to locate the IP address for your device that should be connected to the same network as your NVR.</p>	<p>A list of all connected devices will appear. Select the device from the list by clicking on the checkbox next to the device. Click <b>Add</b> to add the device into the <b>Added Devices</b> menu.</p>	<p>The status of the device should be green indicating the device has been successfully added. If it is red, click on <b>Modify</b> and ensure the password for the device is correct. When it has been added, the device will be ready to view on your NVR.</p>

## Adding to An Amcrest DVR

<p>Log into your Amcrest DVR and click on <b>Camera</b> located under <b>Management</b>. Click on <b>Channel Type</b> in the camera menu and check the IP field. Please note, you can mix and match analog and IP channels if needed. Click Save and allow the DVR to reset</p>	<p>Log back into your DVR and navigate back to the Camera menu. Click on <b>Registration</b> to access the registration menu and click on <b>Device Search</b>.</p>	<p>Locate and click on the device you are adding to your DVR. Click <b>Add</b> to add the device to the DVR. If the status is red, click on <b>Edit</b> and ensure the password for the device is correct. When it has been added, the device will be ready to view on your DVR.</p>

**Note:** You can only select channels from the bottom up in the IP field and can be switched back to Auto from the top down in the Auto field.









# Adding to Amcrest View Pro

Amcrest Smart Home devices such as deterrent cameras, doorbells, or other related Amcrest Smart Home devices, excluding battery cameras, are capable of connecting to both the Amcrest Smart Home app as well as the Amcrest View Pro app.

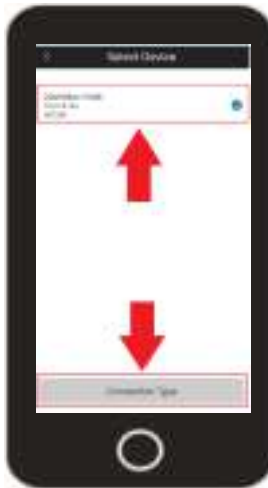
However, since Amcrest Smart Home devices function primarily on a cloud based platform setting up an Amcrest Smart Home device to the Amcrest View Pro app will result in **only live view being available and must be set up first using the Amcrest Smart Home app**. If you would like to view your Amcrest Smart Home devices using the Amcrest View Pro app, please refer to the information provided below.

## Adding to Amcrest View Pro

 <p>Tap on the <b>Settings</b> menu and select <b>Device Manager</b>. Tap on <b>Add Device</b>.</p>	 <p>Tap on <b>Search Device</b>.</p>	 <p>Select your Amcrest Smart Home device from the Device List. Tap on <b>Connection Type</b>.</p>
 <p>Tap on <b>P2P</b>.</p>	 <p>Enter a name for your device and the password. Tap <b>Start Live View</b>.</p>	 <p>Your Amcrest Smart Home device has now been added to your Amcrest View Pro app.</p>

**Note:** Live view features such as, microphone, speaker, etc will be available in the Amcrest View Pro app. Other features such as playback, configuration, etc will not be available. To access and use these settings, please use the Amcrest Smart Home app.



## AD110

### Amcrest 1080P WiFi Video Doorbell Camera

#### Technical Specifications

Model	AD110
<b>Camera</b>	
Image Sensor	1/2.7 2Megapixel CMOS
Night Vision	Up to 16ft
Motion Detection	Up to 16ft
Storage	MicroSD up to 128GB, Class 10 or higher
<b>Lens</b>	
Focal Length	2.0mm
Max Aperture	F2.0
Angle of View	H: 140°
<b>Video</b>	
Compression	H.264
Resolution	1080p HD (1920 x 1080) @ 20fps
<b>Audio</b>	
Compression	G.711
Interface	Built-in Mic & Speaker
<b>Network</b>	
Wi-Fi	2.4GHz, supports 802.11b/g/n
Smart Phone / App	iOS, Android / Amcrest Smart Home
<b>General</b>	
Power Supply	16V ~ 24V AC
Working Temperature	-22°F ~ 122°F, 20~95%RH
Weatherproof Rating	IP55
Dimensions	4.7" x 2.0" x 1.1"
Weight	0.66lbs



## Installing Without an Existing Chime System?

The Amcrest Wi-Fi doorbell requires a 16V-24V AC power connection to function. If new wiring is being installed for your doorbell a third party transformer with 16V-30Va would be efficient to use for installation. Amcrest does not currently sell its own brand of transformers for the doorbell.

The Amcrest Wi-Fi doorbell does not require a chime to function as long as adequate voltage is being applied to the device. Please note, the Amcrest WiFi doorbell also does not require any special resistors and/or diodes to function. It is highly recommended to consult an electrician to establish a proper wired electrical connection for your doorbell if existing wiring is not available.

If you are installing the doorbell without an existing wiring or chime system, a high voltage power adapter (18V, 800mA) can be used to power your device if a wall socket is available. If you are attempting to power the device with a high voltage power adapter, and a chime system is in place during installation, please note that only the doorbell will be usable since the power adapter will not supply adequate voltage to your mechanical or digital chime.

When activated the physical doorbell will chime when pressed via its built-in speaker and a push notification will be sent to your smartphone via the Amcrest Smart Home app allowing you to use your doorbell without existing wiring.

## Why is My Chime Constantly Ringing?

If you have a constantly ringing doorbell, this could be due to the improper voltage due to either a wire short or a fluctuation in the chime system. If your chime is constantly ringing after setup, please ensure the included chime kit (power kit) is properly connected to your existing chime. This will help to regulate the voltage from the chime to the doorbell ensuring proper voltage is being supplied to the chime.

If the chime kit is properly installed to your chime and it is still consistently ringing there may be a wire short somewhere in the system. Make sure to turn the breaker off to your doorbell and check that all wiring is correctly attached to your chime (i.e. the Front and Trans terminals) and that there is no impedance between the transformer and your chime system. If all wiring is properly verified, turn the breaker back on and ensure the problem is resolved. Also, it is good practice to ensure adequate voltage is being supplied to the doorbell and chime system. Use a volt meter to check the voltage to the doorbell as well as the chime system. The proper voltage should range from 16-24V AC and should not have random fluctuations. For more information on issues related to your doorbell, please visit: <https://amcrest.com/doorbellsetup>.

## Why Can't People Hear Me When I Answer a Call?

If you are using the Amcrest Smart Home app on a iOs or Android, go to your settings option on your mobile device and locate the Amcrest Smart Home app. Tap on the app to select it and make sure the microphone toggle for the app is enabled. If the microphone toggle switch for the app is disabled, no one will hear you since the microphone option is disabled on the phone side. If you do not see the microphone option in your smartphone settings, it is recommended to uninstall and reinstall the Amcrest Smart Home app. Please make sure to enable all permissions, including audio, for the app after install is complete.

## Unable to Locate an SSID?

If you are having issues obtaining an SSID when adding your device into the Amcrest Smart Home app there may be a miscommunication happening between the app and your mobile device. This appears to be a more common situation among iOS users and we are currently working with Apple to device a solution. There is an easy fix you can use to resolve the issue. For more information on how to resolve this issue, please refer to the information provided below.

If the SSID for your Wi-Fi network is not pulling up in the app when attempting to add your Amcrest Smart Home device, close the app completely then power your mobile device off and back on again allowing it to restart.

Once your mobile device has finished restarting, ensure your mobile device is connected to the proper Wi-Fi network, open the Amcrest Smart Home app and continue to add your device as normal. The SSID for your network should populate allowing you to complete the setup process.

## How Do I Verify/Update Firmware?

All firmware verification and updates will be available using the Amcrest Smart Home app. For more information on how to verify/update the firmware for your camera, please refer to the information provided below.

- Log into your Amcrest Smart Home account and select your device from the Devices menu.
- Once you are logged in, tap on the settings (  ) icon.
- In the settings menu, locate the "Firmware Update" tab. If a firmware update is necessary there will be a red indication identifier prompting you that a firmware upgrade is ready. If there is not a red dot, you are operating on the most up to date firmware.  
**Note:** If you need to update the firmware, tap on the "**Firmware Update**" tab to proceed with the update.
- In the firmware update menu, you will notice the current version of firmware that is on your camera, and the latest firmware file that will be downloaded to your camera. To proceed with the update, please click on "**Update**".
- You will then be promoted to upgrade the firmware. Tap **Cloud Upgrade** to begin. If you wish to cancel to process tap **Cancel**.
- The firmware file will begin to download from that point. Please wait for the download and upload of the file to complete its processes. Once the process is complete, there see a prompt letting you know that the firmware has successfully updated, and the current version is now updated on your device.

## How Do I Download Recordings?

Due to the current capabilities of the app recordings can only be downloaded via the Cloud Recordings download interface. All recordings retained on a microSD card will have to be downloaded via a microSD card adapter (sold separately) on a computer. For more information on downloading cloud recordings, please refer to the information below.

- Log into your Amcrest Smart Home account and select your device from the Devices menu.
- Tap on Cloud Recordings.
- Tap on the File List icon located in the Cloud playback interface.
- Select the recording you wish to download from the file list.
- Tap the download icon to download the recording.
- The recording will begin to download to your smartphone. A blue check mark will appear next to the download icon once the recording has finished downloading. You can also share your recordings directly to other services on your smartphone via the share icon located in the middle of the download menu.



ISO9001:2000