

# ANKER

SERIES

7

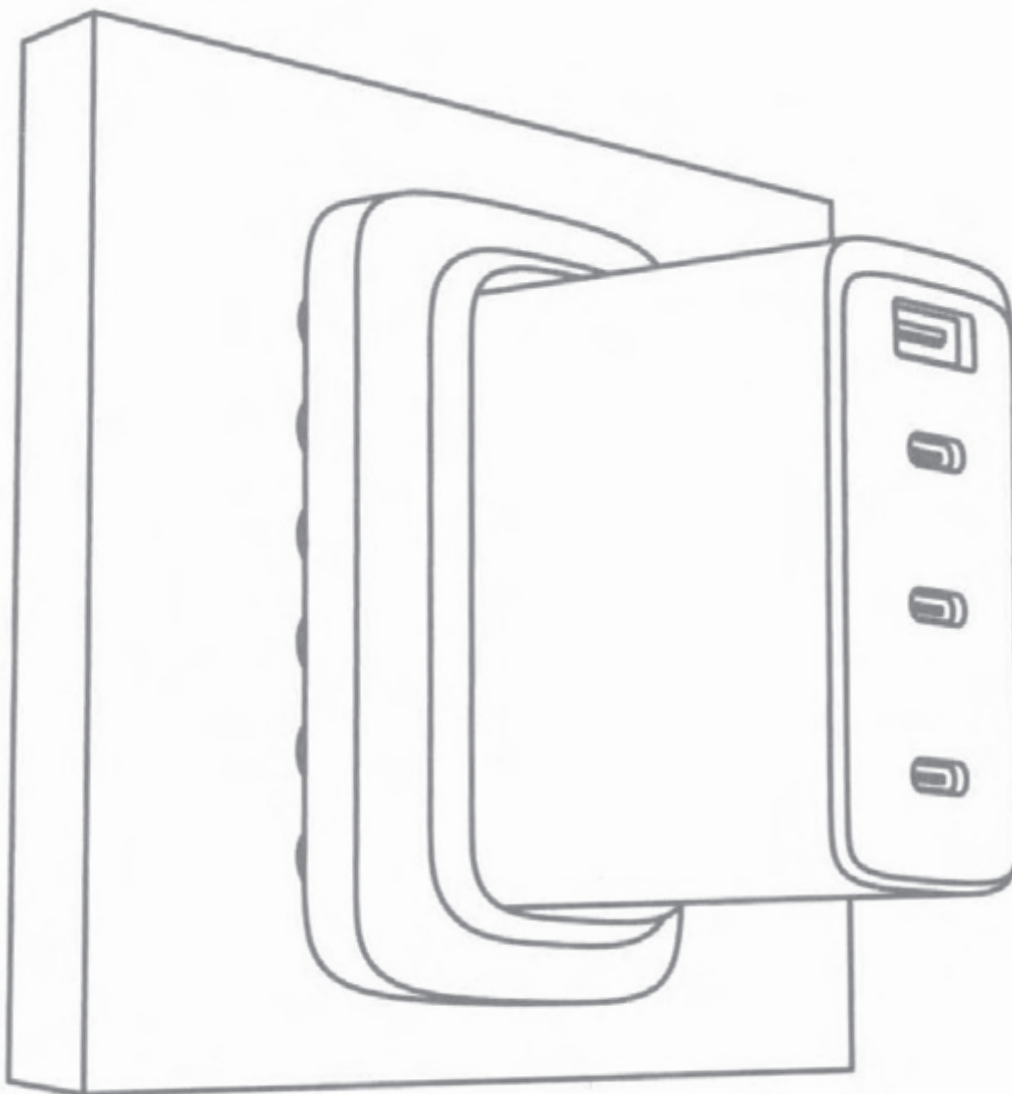

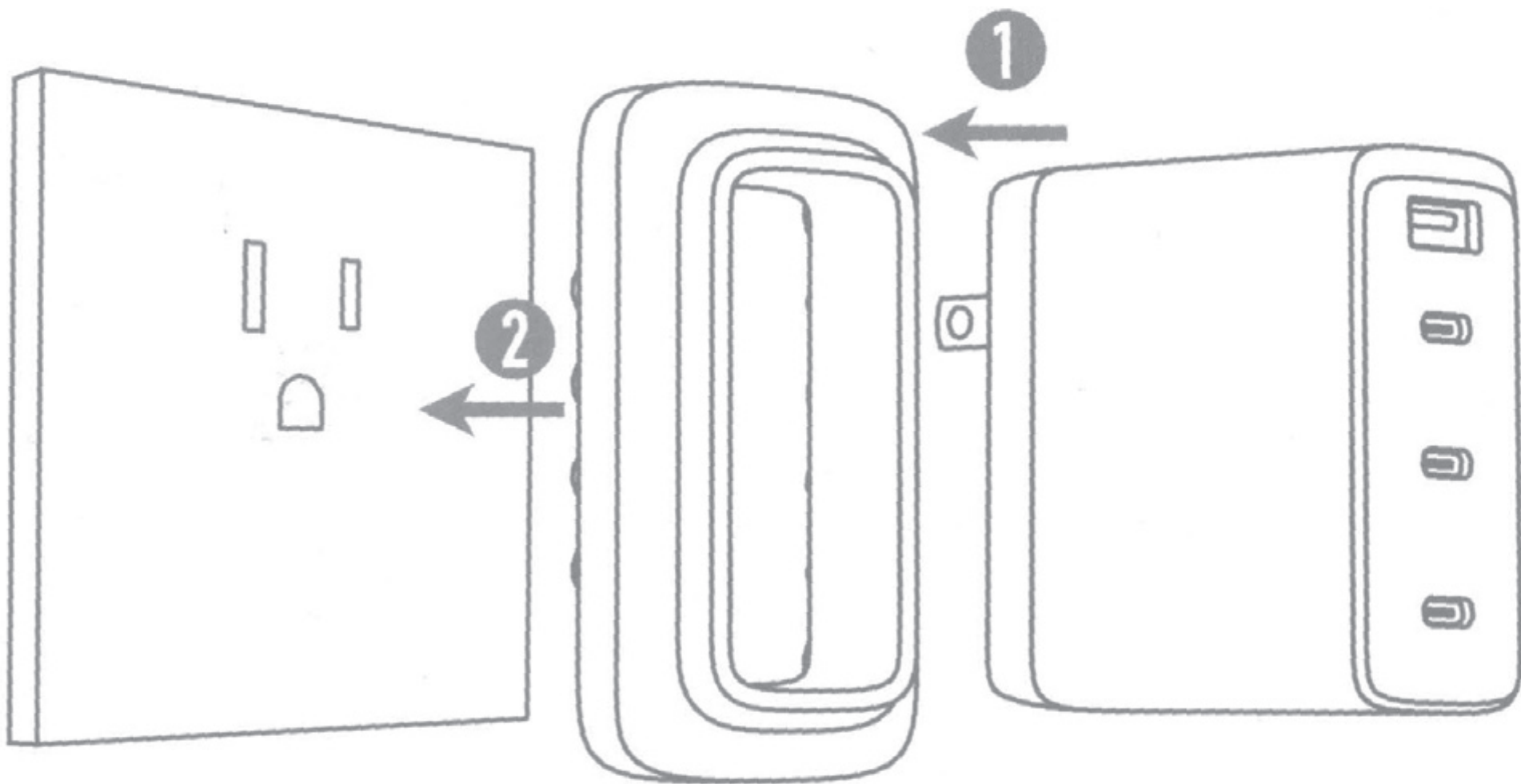

# ANKER

SERIES  7

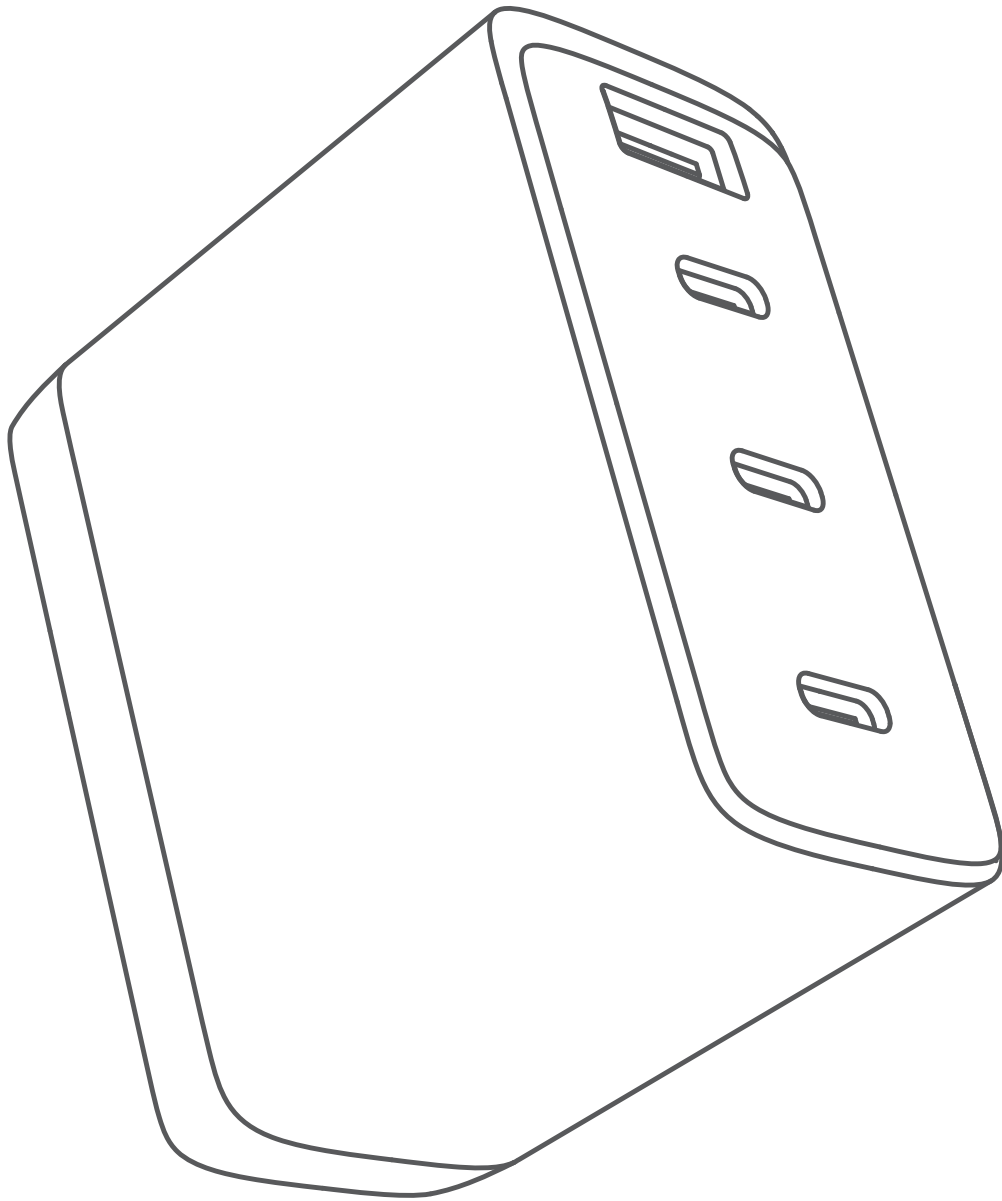

**ANKER 747 CHARGER**  
(GaNPrime 150W)  
**USER MANUAL**

# Attention



Read all the instructions before using the product.

- The product is designed for use with IT equipment only.
- Naked flame sources, such as candles, must not be placed on the product.
- The disconnection from line voltage is made by AC plug.
- In case of broken plugs, the product must be disposed of.
- If you want to clean the product, only use a dry cloth or brush.
- The socket-outlet shall be installed near the equipment and shall be easily accessible.
- The power supply is not intended to be repaired by service personnel in case of failure or component defect (the product can be disposed of).
  
- Le produit est conçu pour être utilisé avec du matériel informatique uniquement.
- Le produit ne doit pas être exposé à des sources de flamme nue, notamment des bougies.
- Débrancher la prise secteur.
- En cas de bouchons cassés, le produit doit être mis au rebut.
- Pour nettoyer le produit, utiliser uniquement une brosse ou un chiffon sec.
- La prise de courant doit se situer à proximité de l'équipement et être facilement accessible.
- L'alimentation n'est pas destinée à être réparée par l'équipe technique en cas de panne ou de défaut de composant (le produit peut être mis au rebut).
  
- 本製品はデジタル機器との接続向けに設計されています。
- 本製品を火気(ろうそくなど)の近くで使用・保管しないでください。
- 電源をオフにする場合は、本製品をコンセントから抜いてください。

# Using Your Product

**DE:** Verwendung Ihres Produkts

**ES:** Uso de su producto

**FR:** Utilisation de votre produit

**IT:** Utilizzo del prodotto

**PT:** Como usar seu produto

**RU:** Использование устройства

**TR:** Ürününüzü Kullanma

**JP:** 本製品の使用方法

**KO:** 제품 사용하기

**简中:** 产品的使用方法

**繁中:** 使用產品

**AR:** استخدام المنتج  
**HE:** השימוש במוצר

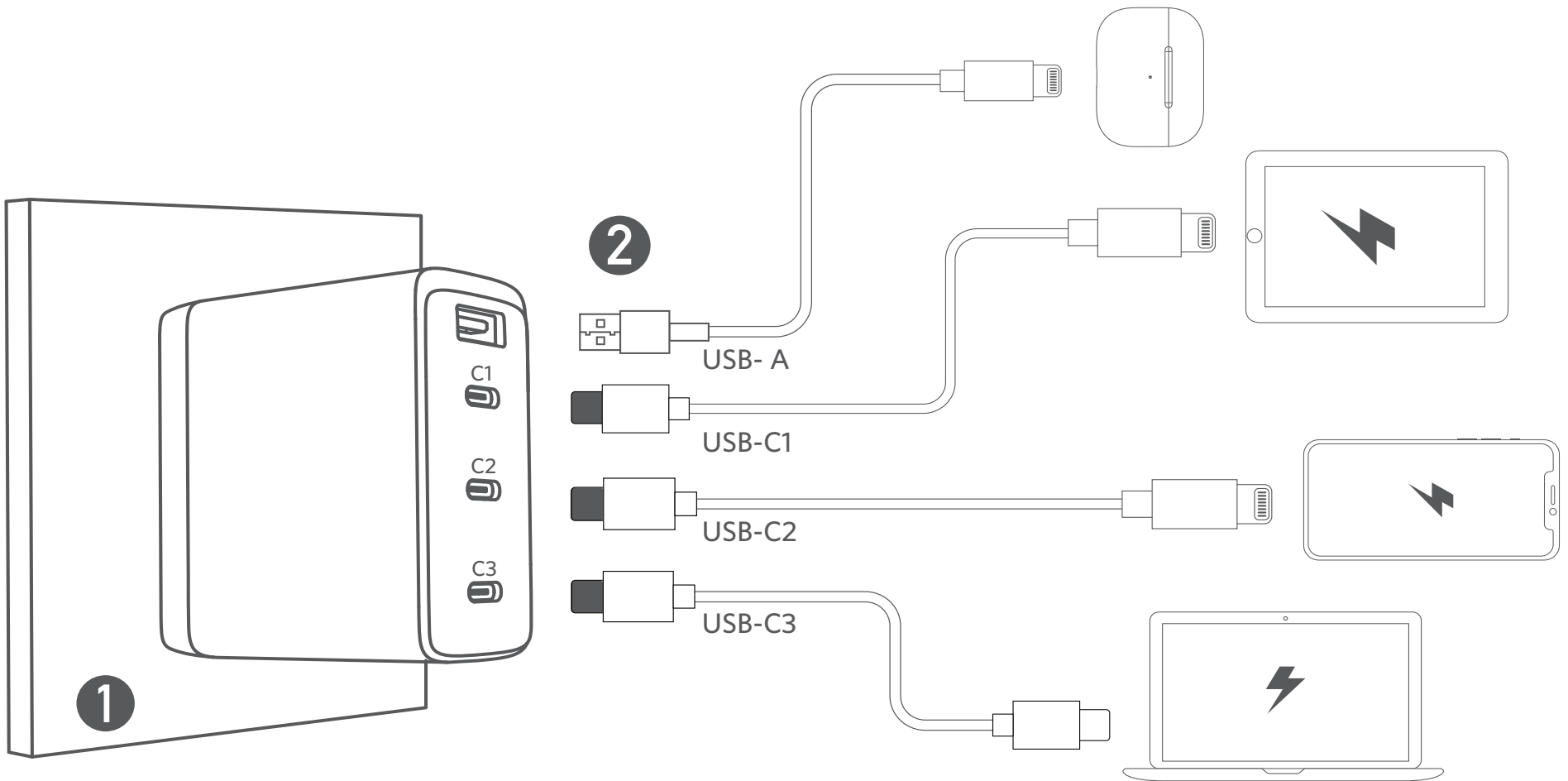



- EN:** For the fastest and safest charge, use an Anker® cable, your device's original cable or another certified cable (such as MFi).
- DE:** Am schnellsten und sichersten ist der Ladevorgang, wenn Sie ein Anker®-Kabel, das Originalkabel des Geräts oder ein anderes zertifiziertes Kabel (z. B. MFi) verwenden.
- ES:** Para cargar de la forma más rápida y segura, utilice un cable Anker®, el cable original del dispositivo o uno certificado (como MFi).
- FR:** Pour une charge sûre et rapide, utilisez un câble Anker®, le câble d'origine de votre appareil, ou un autre câble certifié (MFi, par exemple).
- IT:** Per ricariche più rapide e sicure, utilizzare un cavo Anker®, il cavo originale del dispositivo oppure un altro cavo certificato (ad esempio MFi).
- PT:** Para um carregamento mais rápido e seguro, use um cabo Anker®, que é o cabo original do seu dispositivo, ou outro cabo certificado (como um MFi).
- RU:** Для быстрой и безопасной зарядки используйте кабель Anker®, оригинальный кабель вашего устройства или другой сертифицированный кабель (например, MFi).
- TR:** En hızlı ve güvenli şarj işlemi için Anker® markalı bir kablo, cihazınızın orijinal kablosu veya diğer bir sertifikalı kablo (MFi gibi) kullanın.

## FCC Statement

This device complies with Part 15 of the FCC Rules. Operation is subject to the following two conditions: (1) This device may not cause harmful interference, and (2) this device must accept any interference received, including interference that may cause undesired operation.

**Warning:** Changes or modifications not expressly approved by the party responsible for compliance could void the user's authority to operate the equipment.

**Note:** This equipment has been tested and found to comply with the limits for a Class B digital device, pursuant to Part 15 of the FCC Rules. These limits are designed to provide reasonable protection against harmful interference in a residential installation.

This equipment generates, uses, and can radiate radio frequency energy and, if not installed and used in accordance with the instructions, may cause harmful interference to radio communications. However, there is no guarantee that interference will not occur in a particular installation. If this equipment does cause harmful interference to radio or television reception, which can be determined by turning the equipment off and on, the user is encouraged to try to correct the interference by one or more of the following measures:

- (1) Reorient or relocate the receiving antenna.
- (2) Increase the separation between the equipment and receiver.
- (3) Connect the equipment into an outlet on a circuit different from that to which the receiver is connected.
- (4) Consult the dealer or an experienced radio / TV technician for help.

The following importer is the responsible party (for FCC matters only).

Company Name: Fantasia Trading LLC

Address: 5350 Ontario Mills Pkwy, Suite 100, Ontario, CA 91764

Telephone: +1 (800) 988 79733

This device complies with Industry Canada license-ICES-003. Operation is subject to the following two conditions: (1) This device may not cause interference, and (2) This device must accept any interference, including interference that may cause undesired operation of the device.

Le présent appareil est conforme aux CNR d'Industrie Canada applicables aux appareils radio exempts de licence. L'exploitation est autorisée aux deux

conditions suivantes : (1) l'appareil ne doit pas produire de brouillage, et (2) l'utilisateur de l'appareil doit accepter tout brouillage radioélectrique subi, même si le brouillage est susceptible d'en compromettre le fonctionnement.

## IC Statement

This digital apparatus complies with CAN ICES-003(B)/NMB-003(B).

## Declaration of Conformity

Hereby, Anker Innovations Limited declares that this product is in compliance with Directive 2014/35/EU & 2014/30/EU & 2011/65/EU & 2009/125/EC & 2019/1782/EU. The full text of the EU declaration of conformity is available at the following internet address: <https://www.anker.com>.

Hereby, Anker Innovations Limited declares that this product is in compliance with Electrical Equipment (Safety) Regulations 2016 & Electromagnetic Compatibility Regulations 2016 & The Restriction of the Use of Certain Hazardous Substances in Electrical and Electronic Equipment Regulations 2012 & The Ecodesign for Energy-Related Products Regulations 2010. The full text of the GB declaration of conformity is available at the following internet address: <https://www.anker.com>.

## بيان لجنة الاتصالات الفيدرالية (FCC)

يتوافق هذا الجهاز مع الفقرة 15 من قواعد لجنة الاتصالات الفيدرالية. يخضع التشغيل للشرطين التاليين: (1) قد لا يتسبب هذا الجهاز بتداخلات ضارة و(2) يجب أن يقبل هذا الجهاز تلقي أي تداخل، بما في ذلك التداخل الذي قد يؤدي إلى تشغيل الجهاز بشكل غير مرغوب فيه. تحذير: قد تؤدي التغييرات أو التعديلات غير الموافق عليها صراحةً من قبل الجهة المسؤولة عن التوافق إلى إبطال صلاحية المستخدم لتشغيل الجهاز. ملاحظة: تم اختبار هذا الجهاز وثبت أنه متوافق مع حدود الأجهزة الرقمية من الفئة (ب) بموجب الفقرة 15 من قواعد لجنة الاتصالات الفيدرالية (FCC). تم تصميم هذه القيود لتوفير حماية معقولة من التداخل الضار في أي تركيب داخلي.

يولد هذا الجهاز طاقة من ترددات موجات الراديو ويستخدمها ومن الممكن أن يشعها، وإذا لم يتم تثبيته واستخدامه وفقاً للتعليمات، فقد يتسبب ذلك بحدوث تداخل ضار في الاتصالات اللاسلكية. ومع ذلك، لا يوجد ضمان بعدم حدوث تداخل في تثبيت معين. إذا تسبب هذا الجهاز بحدوث تداخل ضار في استقبال موجات الراديو أو موجات التلفاز، الأمر الذي يمكن تحديده عن طريق إيقاف تشغيل الجهاز وتشغيله، ينبغي على المستخدم محاولة تصحيح التداخل من خلال اتباع إجراء واحد أو أكثر من الإجراءات التالية:

## הוראות בטיחות חשובות למטענים לרכב :

- יש לקרוא את הוראות הבטיחות הרשומות מטה. אי מילוי ההוראות עלול לגרום לשריפה, התחשמלות או כל מפגע אחר העלול להוביל לפגיעה גופנית חמורה.
1. אין לפרק/לפתוח/להפיל או לגרום כל נזק אחר למוצר.
  2. אין לחשוף את המוצר לנוזל וללחות.
  3. יש להרחיק את המוצר מחום, אור שמש ישירה ואש.
  4. יש להרחיק מכשור בעל מתח גבוה.
  5. יש להרחיק מילדים.



Indoor use only



This symbol indicates that this product shall not be treated as household waste. Instead it shall be handed over to the applicable collection point for the recycling of electrical and electronic equipment.

Anker Innovations Limited  
Room 1318-19, Hollywood Plaza, 610 Nathan Road, Mongkok,  
Kowloon, Hong Kong

The following importer is the responsible party (contract for EU and UK matters)

Anker Innovations Deutschland GmbH | Georg-Muche-Strasse 3,  
80807 Munich, Germany

Anker Technology (UK) Limited | GNR8, 49 Clarendon Road,  
Watford, Hertfordshire, WD17 1HP, United Kingdom



仅适用于海拔 2000 米及以下地区



仅适用于非热带地区安全使用

# Specifications

DE: Technische Daten | ES: Especificaciones

FR: Spécifications techniques | IT: Specifiche | PT: Especificações

RU: Технические характеристики | TR: Teknik Özellikler | JP: 製品の仕様 |

KO: 사양 | 簡中: 规格 | 繁中: 規格 | :AR المواصفات | HE: מפרט

<p>Input 入力</p>	<p>100-240V~2.3A 50-60Hz</p>
<p>Output 出力</p>	<p><b>Use One Port (1 ポート利用時):</b>          Use 1 Port Output/ 出力          USB-C1(Top Type-C Port)  <b>USB-C1/USB-C2 /USB-C3:</b>          5V ≡ 3A /9V ≡ 3A /15V ≡ 3A /20V ≡ 5A(100W Max)  <b>USB-A :</b>          5V ≡ 3A /5V ≡ 4.5A /9V ≡ 2A/          12V ≡ 1.5A / 4.5V ≡ 5A (22.5W Max)</p> <p><b>Use Two Ports (2 ポート利用時):</b>          USB-C1+USB-C2 : 150W Max          USB-C2+USB-C3 : 150W Max          USB-C1+USB-C3 : 150W Max          USB-C1+USB-A :5V ≡ 4.8A(24W Max)          USB-C2/C3+USB-A: 100W+22.5W Max</p> <p><b>Use Three Ports (3 ポート利用時):</b>          USB-C1+USB-C2+USB-C3: 150W Max          USB-C2+(USB-C1+USB-A):100W+24W Max          USB-C3+(USB-C1+USB-A): 100W+24W Max          USB-C2+USB-C3+USB-A:150W Max</p> <p><b>Use Four Ports (4 ポート利用時):</b>150W Max          Total Output (合計出力) : 150W Max</p>

Average Active Efficiency 平均変換効率	84.93%
Efficiency at Low Load (10%) 低負荷時の変換効率 (10%負荷時)	71.71%
No-Load Power Consumption 無負荷時の電力消費	0.23W
Recommended Operating Temperature 使用時の推奨温度	0°C ~ 25°C / 32 °F - 77 °F

Note: To ensure electrical safety and product performance, the output power may fluctuate based on the ActiveShield™ 2.0\* safety mechanism when the ambient temperature is between 26-35°C (78.8-95°F) with a high output load.

\*ActiveShield™ 2.0 enhances protection by intelligently monitoring temperature and adjusting power output to safeguard your connected devices.

(注意) 安全および製品の性能を確保するため、周囲の温度が26～35°Cで出力負荷が高い場合、ActiveShield™ 2.0\*の働きによって本製品の出力が変動することがあります。

\*ActiveShield™ 2.0は、温度を感知し、出力を調整することによって接続デバイスの安全を確保します。

注意：为确保产品的安全使用，当环境温度在 26-35°C 之间，且输出功率较高时，输出功率可能会因为 AI 智能控温技术 2.0\* 而波动。

\*AI 智能控温技术 2.0 通过智能监控温度和调整功率输出，保护您的设备。

# Customer Service

**DE:** Kundenservice | **ES:** Atención al Cliente | **FR:** Service Client

**IT:** Servizio Clienti | **PT:** Serviço de Apoio ao Cliente

**RU:** Обслуживание клиентов | **TR:** Müşteri Hizmetleri

**JP:** カスタマーサポート | **KO:** 고객 서비스 | **簡中:** 客服支持

**繁中:** 客戶服務 | **AR:** خدمة العملاء | **HE:** שירות לקוחות



**EN:** 24-month limited warranty\*

**DE:** 24 Monate eingeschränkte Garantie\*

**ES:** Garantía limitada de 24 meses\*

**FR:** Garantie limitée de 24 mois\*

**IT:** Garanzia limitata di 24 mesi\*

**PT:** Garantia de até 24 meses

**RU:** Ограниченная гарантия на 24 месяцев

**TR:** 24 aylık sınırlı garanti

**JP:** 通常保証24ヶ月 (延長あり)

**KO:** 24개월 제한 보증

**簡中:** 有限保修 24 个月

**繁中:** 24 個月有限保固

**AR:** ضمان محدود لمدة 24 شهرًا

**HE:** אחריות מוגבלת למשך 24 חודשים

**\*EN:** Please note that your rights under applicable law governing the sale of consumer goods remain unaffected by the warranties given in this Limited Warranty.

**DE:** Die gesetzlichen Gewährleistungspflichten bleiben von der beschränkten Herstellergarantie unberührt.

**ES:** Tenga en cuenta que los derechos que le conceden las leyes aplicables que rigen la venta de bienes de consumo no se ven afectados por las garantías que proporciona esta garantía limitada.

**FR:** Notez que vos droits dans le cadre de la législation régissant la vente de biens de consommation ne sont pas affectés par les garanties accordées dans cette garantie limitée.

**IT:** Si prega di notare che i diritti del cliente ai sensi della legge applicabile in materia di vendita di beni di consumo non sono influenzati dalle garanzie concesse dalla presente Garanzia limitata.



**EN:** Lifetime technical support  
**DE:** Technischer Support für die Produktlebensdauer  
**ES:** Asistencia técnica de por vida  
**FR:** Assistance technique à vie  
**IT:** Supporto tecnico per l'intero ciclo di vita  
**PT:** Suporte técnico vitalício  
**RU:** Техническая поддержка на весь срок эксплуатации  
**TR:** Ömür boyu teknik destek  
**JP:** テクニカルサポート | **KO:** 평생 기술 지원  
**简中:** 终身技术支持 | **繁中:** 永久技術支援  
**HE:** תמיכה טכנית לכל החיים | **AR:** دعم تقني دائم



support@anker.com  
support.me@anker.com (For Middle East and Africa Only)



(US) +1 (800)988 7973 Mon-Fri 6:15 - 17:00 (PT)  
(UK) +44 (0) 1604 936200 Mon-Fri 6:00-17:00;  
Sat-Sun 6:00-14:00  
(DE) +49 (0) 69 9579 7960 Mo-Fr 6:00 - 11:00  
(Middle East & Africa) +971 42463266 Sun-Thu 9:00 - 17:30  
(UAE) +971 8000320817 Sun-Thu 9:00 - 17:30  
(KSA) +966 8008500030 Sun-Thu 8:00 - 16:30  
(Kuwait) +965 22069086 Sun-Thu 8:00 - 16:30  
(Egypt) +20 8000000826 Sun-Thu 7:00 - 15:30  
(AU) +61 3 8331 4800 Mon-Fri 8:30 - 17:00 (AEST)  
(TR) +90 0850 460 14 14 Mon-Fri 9:00 - 18:00  
(RU) +8 (800) 511-86-23 Mon-Fri 9:00 - 18:00 (MSK)  
(中国) +86 400 0550 036 周一至周五 9:00 - 17:30  
(日本) 03 4455 7823 平日 9:00 - 17:00 / 年末年始を除く  
(한국) +82 02-1670-7098 월 - 금 10:00 - 17:00

For FAQs and more information, please visit:

**[anker.com/support](https://anker.com/support)**



@anker\_official  
@anker\_jp



@Anker Deutschland  
@Anker Japan  
@Anker



@AnkerOfficial  
@Anker\_JP