



Wireless Car Charger with Sucker Stand

User Manual

42829584

Notice :

Please read user manual carefully before any operations and keep it for your records.

Safety instructions:

1. Do not disassemble or throw into fire or water, to avoid damage.
2. Do not use wireless charger in severely hot, humid or corrosive environments, to avoid circuit damage.
3. Do not place too close with magnetic stripe or RFID card (ID card, credit cards, etc.) to avoid magnetic failure.
4. Please keep the distance at least 30cm between implantable medical devices (pacemakers, implantable cochlear, etc.) and the wireless charger, to avoid potential interference with the medical device.
5. Some phone case may affect the charging performance. Ensure there is no any metal object between your phone cases. The wireless charger will stop charging if any metal object detected. In case of this issue, remove the phone case before charging.
6. Use with provided car charger only.

Package includes:

- 1 x Qi Wireless Charging Pad
- 1 x 12V/2A Car Charger
- 1 x Stand
- 1 x User Manual

Features

Charge for any Qi compatibly wireless device such as Apple or Samsung smartphone.

Step 1: Place the sucker stand snap joints at the back of Qi charging pad

Step 2: Tear off the protective film from the bottom of the sucker stand. Attach sucker stand to the dashboard or the window of the car.

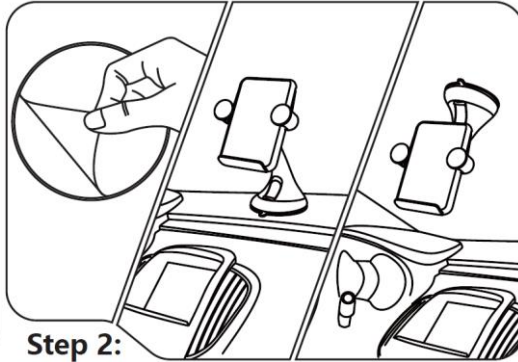
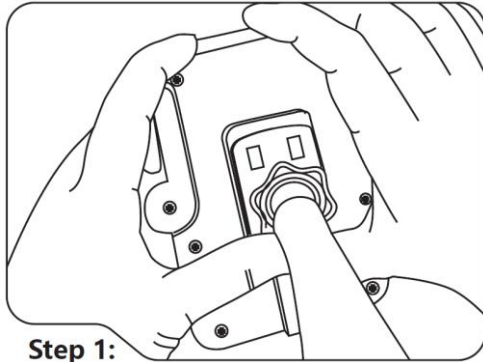

Step 3: Plug the DC jack into the wireless charging pad.

Step 4: Insert the car charger into the car cigarette lighter.

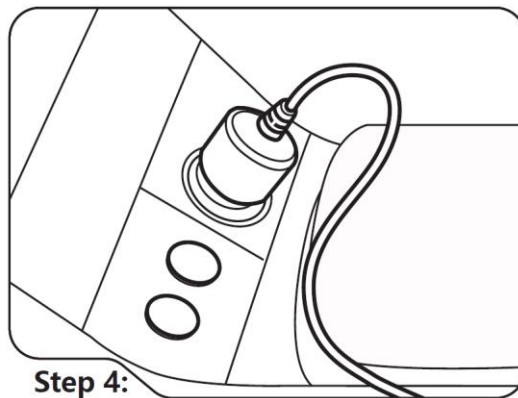
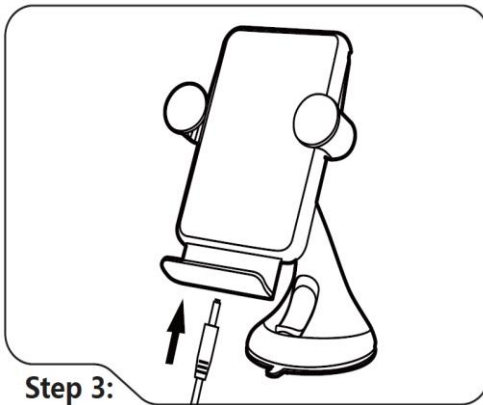

Step 5: Adjust the height to fix various size of smartphone by the button at the back.

Step 6: Place the Qi device on top of the pad for wireless charge.

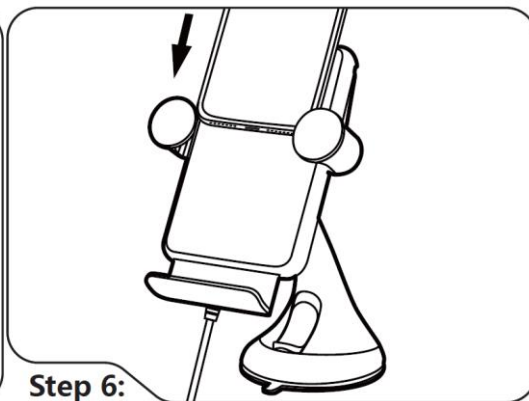
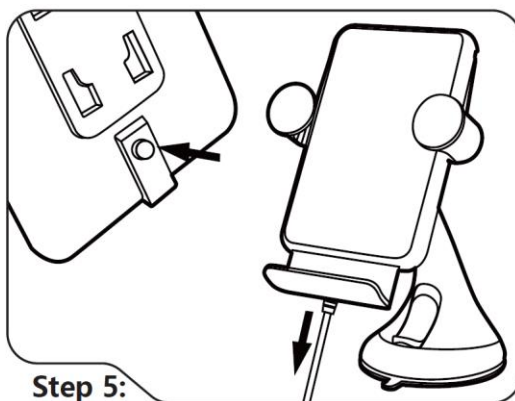

Specification:**Qi Wireless Charging Pad**

Input: 12V 2A

Charging Mode: Support Qi charging up to 15W

Dimensions:

Qi Wireless Charging Pad: 112x101x36mm

12V 2A Car Charger (DC2.5 Jack)

Input: 12-24VDC

Output: 12V 1.8A

12 Month Warranty

Thank you for your purchase from Kmart.

Kmart Australia Ltd warrants your new product to be free from defects in materials and workmanship for the period stated above, from the date of purchase, provided that the product is used in accordance with accompanying recommendations or instructions where provided. This warranty is in addition to your rights under the Australian Consumer Law.

Kmart will provide you with your choice of a refund, repair or exchange (where possible) for this product if it becomes defective within the warranty period. Kmart will bear the reasonable expense of claiming the warranty. This warranty will no longer apply where the defect is a result of alteration, accident, misuse, abuse or neglect.

Please retain your receipt as proof of purchase and contact our Customer Service Centre on 1800 124 125 (Australia) or 0800 945 995 (New Zealand) or alternatively, via Customer Help at Kmart.com.au for any difficulties with your product. Warranty claims and claims for expense incurred in returning this product can be addressed to our Customer Service Centre at 690 Springvale Rd, Mulgrave Vic 3170.

Our goods come with guarantees that cannot be excluded under the Australian Consumer Law. You are entitled to a replacement or refund for a major failure and compensation for any other reasonably foreseeable loss or damage. You are also entitled to have the goods repaired or replaced if the goods fail to be of acceptable quality and the failure does not amount to a major failure.

For New Zealand customers, this warranty is in addition to statutory rights observed under New Zealand legislation.