

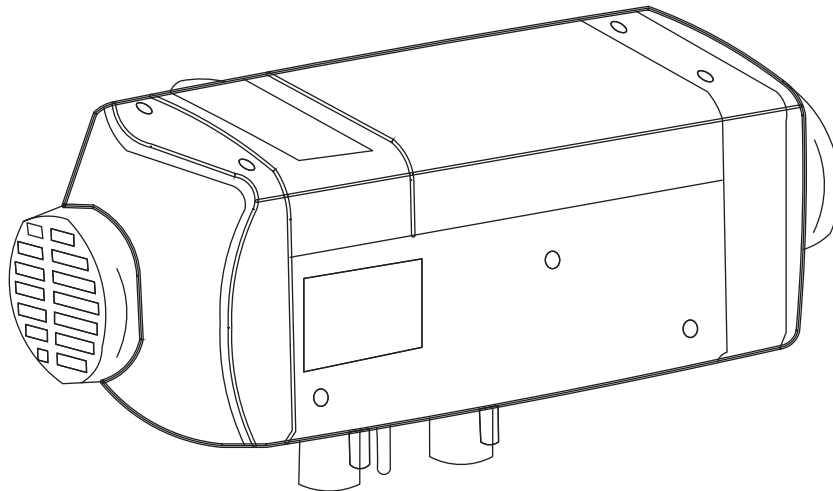

# 12V 2kW DIESEL HEATER

## USER MANUAL



READ CAREFULLY BEFORE USING  
RETAIN MANUAL FOR FUTURE REFERENCE

More information <https://www.caravansplus.com.au>

# CONTENTS

<b>PRODUCT INTRODUCTION</b>	<b>1</b>
<b>OPERATION</b>	<b>2</b>
OLED Panel	2
Display	2
Settings	4
Communication & Fault	6
Bluetooth & Upgrades	7
<b>MAINTENANCE</b>	<b>8</b>
<b>WARRANTY STATEMENT</b>	<b>9</b>



Read this installation instruction thoroughly.  
Incorrect installation or operation may void any warranty.  
Incorrect use or operation may cause serious injury.

## PRODUCT INTRODUCTION

The Aussie Traveller 12 2kW Diesel Heater will quickly warm your caravan or RV on those cold Winter days.

This compact designed 12V Diesel Heater has excellent fuel efficiency and power consumption. You won't even notice that the whisper quiet heater is running, enjoy the warmth while you watch TV or have a casual conversation.

The 12V 2kW Diesel Heater also comes equipped with Automatic Altitude Adjustment. It has a working height all the way up to 5000m above sea level so you won't have to worry about getting cold anywhere in Australia.

The heater is a small fuel furnace controlled by a single-chip micro-processor. Its furnace body (the heat exchanger) is located in the hood shaped case, which serves as an independent air passage. Cold air is drawn into the air passage by the fan, heated by the heat exchanger and blown out as hot air.

The heater is supplied as standard with an easy-to-read digital display and complete installation kit.

### 10L DIESEL FUEL TANK

Also available to complement the 12V 2kW Diesel heater is a slimline black fuel tank.

The fuel tank includes all fixings and measures 410 × 205 × 112mm making it easy to install anywhere that is convenient in your van thanks to its compact size.

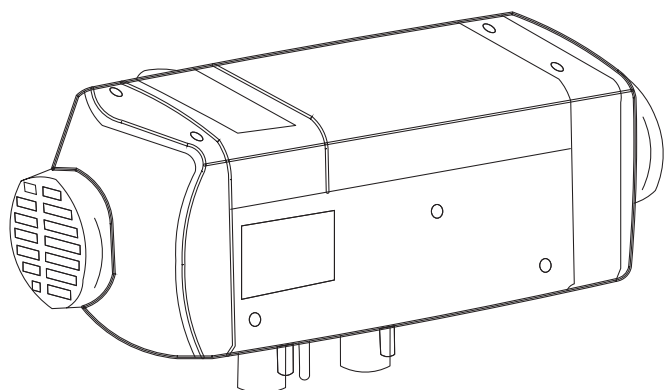
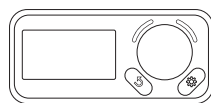

1300 663 868 | [enquiries@aussietraveller.com.au](mailto:enquiries@aussietraveller.com.au) | [aussietraveller.com.au](http://aussietraveller.com.au)

BRISBANE SHOWROOM: 11-15 Oasis Court, Clontarf QLD 4019 | MELBOURNE SHOWROOM: 235 Barry Road, Campbellfield VIC 3061

# OPERATION

## OLED PANEL

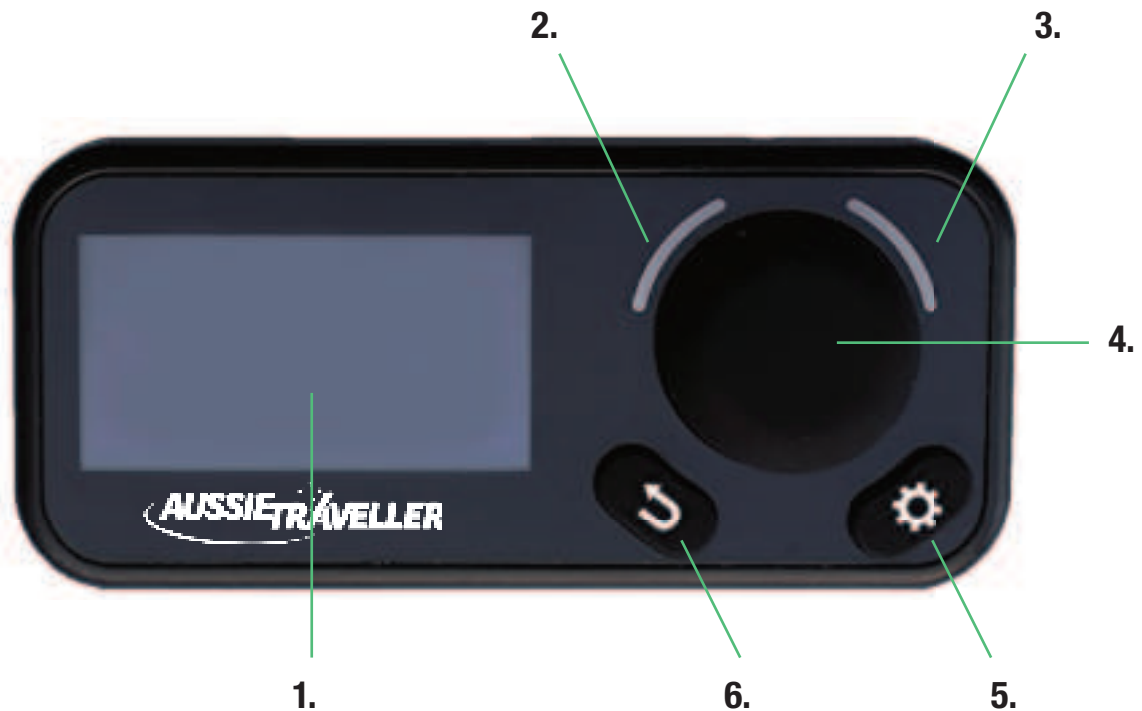

1. OLED display screen
2. LED indicator
3. LED indicator
4. Rotary knob & confirmation button
5. Settings button
6. Back button

### 1. DISPLAY

- After powering on, the panel enters the initialisation state.
- Once the initialisation is complete, the panel enters the control interface. (Fig. 1)



The screen display contents:

- Operation Mode
- Intensity Adjustment
- State of Heater



Fig. 1

#### 1.1 OPERATION MODE

- Variable Heat Mode
- Thermostat Mode
- Ventilation Mode



Variable Heat Mode



Thermostat Mode



Ventilation Mode

1300 663 868 | enquiries@aussietraveller.com.au | aussietraveller.com.au

BRISBANE SHOWROOM: 11-15 Oasis Court, Clontarf QLD 4019 | MELBOURNE SHOWROOM: 235 Barry Road, Campbellfield VIC 3061



More information <https://www.caravansplus.com.au>

## OPERATION (cont.)

### 1.2 MODE SETTINGS

- Under the mode settings, under the interface (Fig. 1) press the confirmation button.
- Change the selection mode by rotating the knob.
- Press the confirmation button.
- Press the back button to exit selection mode.

**NOTE:** Press = <2.5 seconds. Hold = >2.5 seconds.

#### TO SET HEAT MODE WARM AIR RANGE (P1-P7)

P1 is the minimum heat setting.  
P7 is the maximum heat setting.  
Adjust the setting with the rotary knob.

#### TO SET TEMPERATURE MODE RANGE (5-35°C)

5°C minimum room temperature.  
35°C maximum room temperature.  
Adjust the temperature with the rotary knob.

#### TO SET VENTILATION MODE (FAN ONLY) RANGE (P1-P7)

P1 is the minimum fan speed.  
P7 is the maximum fan speed.  
Adjust the fan speed with the rotary knob.



### 1.3 WORK STATE

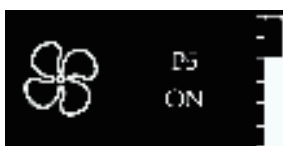

#### HEATER IS ON

Press the confirmation button to enter mode settings.

Hold to turn off the heater.



#### HEATER IS TURNING OFF

Press the confirmation button to enter mode settings.

Hold to turn off the heater.



#### HEATER IS OFF

Press the confirmation button to enter mode settings.

Hold to turn off the heater.

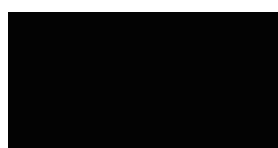

#### STAND BY (SCREEN OFF)

Press any button to exit stand by.

- After the heater is completely turned off, the panel will automatically enter standby mode.
- When the heater is working in heat mode or temperature mode, switching to fan only mode is not possible.

1300 663 868 | enquiries@aussietraveller.com.au | aussietraveller.com.au

BRISBANE SHOWROOM: 11-15 Oasis Court, Clontarf QLD 4019 | MELBOURNE SHOWROOM: 235 Barry Road, Campbellfield VIC 3061

# OPERATION (cont.)

## 2. SETTINGS

- Press setting button to enter settings.
- Switch settings with the rotary knob.
- Press the back button to exit settings.

### 2.1 LANGUAGE SETTINGS

**NOTE:** The language settings have a memory function and will not change if the heater is turned off.

- In settings, select Language by pressing the confirmation button.
- Switch the language options with the rotary knob.
- Confirm the selected language by pressing the confirmation button.
- To exit language settings press the back button.

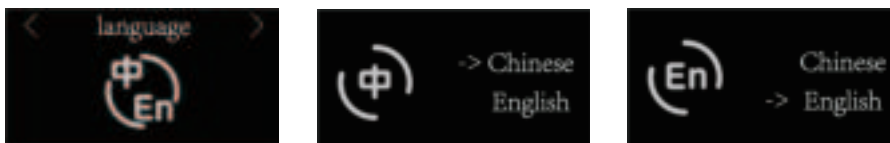

### 2.2 BLUETOOTH SETTINGS - NOT AVAILABLE ON ALL MODELS

**NOTE:** The Bluetooth settings have a memory function and will not change if the heater is turned off.

- In settings, select Bluetooth by pressing the confirmation button.
- Switch between Bluetooth ON or OFF with the rotary knob.
- Confirm Bluetooth settings by pressing the confirmation button.
- To exit Bluetooth settings press the back button.



### 2.3 SOUND SETTINGS

**NOTE:** The sound settings have a memory function and will not change if the heater is turned off.

- In settings, select Sound by pressing the confirmation button.
- Switch between sound ON or OFF with the rotary knob.
- Confirm sound settings by pressing the confirmation button.
- To exit sound settings press the back button.

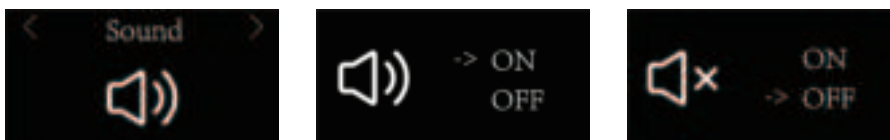

1300 663 868 | enquiries@aussietraveller.com.au | aussietraveller.com.au

BRISBANE SHOWROOM: 11-15 Oasis Court, Clontarf QLD 4019 | MELBOURNE SHOWROOM: 235 Barry Road, Campbellfield VIC 3061



More information <https://www.caravansplus.com.au>

# OPERATION (cont.)

## 2.4 INFORMATION

**NOTE:** Monitoring mode is used by service technicians.

- In settings, select Information by pressing the confirmation button.
- Switch between the information displays with the rotary knob.
- To exit the information display, press the back button.



HEATER INFORMATION



CONTROL PANEL INFORMATION

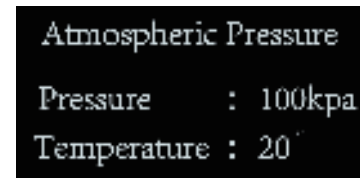

ATMOSPHERIC PRESSURE INFORMATION

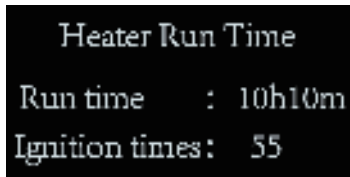

HEATER RUN TIME



MONITOR MODE

## 2.5 FUEL PRIMING

**NOTE:** Fuel priming will prime the heater with fuel from the tank for up to 90 seconds if it detects it needs fuel.

- Under the 'Working Time' interface, hold the back and settings buttons.
- When Fig. 2 appears, press the confirmation button.
- To exit quick pumping oil, press the back button.
- When in the Quick Pumping Oil interface, use the rotary knob to adjust the time regulation.
- To exit quick pumping oil, press the back button.

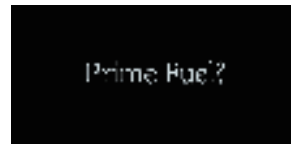

Fig. 2



## 2.6 FACTORY RESET

**NOTE:** Factory Reset restores the language, Bluetooth, sound and other related settings back to the original factory settings.

- Press the confirmation button to enter factory data reset settings.
- Switch the settings options with the rotary knob.
- Press the confirmation button to factory reset.
- Exit reset by pressing the back button.



1300 663 868 | enquiries@aussietraveller.com.au | aussietraveller.com.au

BRISBANE SHOWROOM: 11-15 Oasis Court, Clontarf QLD 4019 | MELBOURNE SHOWROOM: 235 Barry Road, Campbellfield VIC 3061

## OPERATION (cont.)

### 2.7 COUNTDOWN MODE

**NOTE:** The time can be set in hours and minutes. When the countdown ends, the heater turns on.

- Press the setting button to enter timer mode settings.
- Switch the settings options with the rotary knob.
- Use rotary knob to select timer mode, press to confirm.



#### 1. SELECTION MODE

Press the confirmation button to select the operation mode.  
To change the selection mode, use the rotary knob.  
To exit the selection mode, press the back button.



#### 2. MODE PARAMETERS

Press the confirmation button to select the mode parameters.  
To change the mode parameters, use the rotary knob.  
To exit the mode parameters, press the back button.



#### 3. SET TIME FOR DELAYED START

Press the confirmation button to set the time.  
Use the rotary knob to adjust the time.  
To exit set time, press the back button.

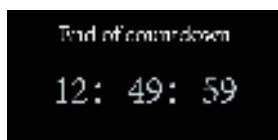

The heater will turn on when the countdown reaches 0.

## 3. COMMUNICATION & FAULT

- When communication is abnormal, a prompt will appear.
- When a fault occurs, the heater will enter the fault lock state.
- Hold the confirmation button to exit the lock state and the heater will close.

### 3.1 INITIALISE

**NOTE:** When initialising, if the panel fails to communicate to the heater, the panel enters the disconnected state.

- Panel is initialising and communicating with the heater.



### 3.2 NO CONNECTION

**NOTE:** If the 'No Connection' state appears, check the communication cable first.

- Communication with the heater failed.
- Press any keys to initialise.



### 3.3 COMMUNICATION DISCONNECT

**NOTE:** If the 'Disconnect' state appears, check the communication cable first.

- Communication between panel and heater is disconnected.
- Communication recovery automatically exits.



1300 663 868 | enquiries@aussietraveller.com.au | aussietraveller.com.au

BRISBANE SHOWROOM: 11-15 Oasis Court, Clontarf QLD 4019 | MELBOURNE SHOWROOM: 235 Barry Road, Campbellfield VIC 3061



More information <https://www.caravansplus.com.au>

## OPERATION (cont.)

### 3.4 FAULT

**NOTE:** After exiting the fault state, please wait until the heater is completely turned off before restarting the heater. Otherwise, the heater may not exit the fail-lock state.

- The control panel will display the fault code and description.
- Example fault code 31: Undervoltage
- To exit the fault code, hold the confirmation button.



## 4. LED INDICATOR

You can easily see the status of the heater by the LED indicator colours and patterns. The following corresponds to the different states.

STATUS	LED DISPLAY
Initialise	Blue light
Disconnect	Blue light flashing
Working	Green light
Shutting down	Red light
Fault	Green light flashing

## 5. BLUETOOTH & UPGRADES

**NOTE: NOT AVAILABLE ON ALL MODELS**

- The heater has Bluetooth support and can use the (BLF) APP connection control on smart devices.
- To use the Bluetooth function, please refer to the user manual of the (BLF) APP.

### 5.1 BLUETOOTH

**NOTE:** When the control panel is controlled by the app, the command is executed with the latest command.

- When the Bluetooth is connected, the Bluetooth icon will appear in the top corner.
- Real-time app control
- Modify Bluetooth name
- Query fault
- Remote upgrade



### 5.2 UPGRADES

- When the update screen is displayed, the heater or the control panel are upgrading.
- The panel will automatically exit upgrading with the upgrade is complete.



1300 663 868 | [enquiries@aussietraveller.com.au](mailto:enquiries@aussietraveller.com.au) | [aussietraveller.com.au](http://aussietraveller.com.au)

BRISBANE SHOWROOM: 11-15 Oasis Court, Clontarf QLD 4019 | MELBOURNE SHOWROOM: 235 Barry Road, Campbellfield VIC 3061

## MAINTENANCE

Once the heater is installed, it should ideally be turned on a few times to remove any air trapped in the fuel lines. Also ensure there is no leaking from the lines and that all electric terminals fit securely together.

You should also regularly:

- Check the air inlet and outlet for any pollution or foreign matters
- Clean the externals of the heater
- Check for corrosion or loose connections of the circuits
- Check the combustion air inlet and exhaust pipe for damage and clogs
- Check the fuel line for leaks

To ensure a long life of the heater it is advised that you run it for at least 10 minutes every month, to prevent malfunction of mechanical parts.

After 10 years the heat exchanger, overheat sensor and exhaust should be replaced by a professional.

If any welding is being attempted on the vehicle, please remove the positive power supply wire and earth it to protect the controller from any damage.



***THE 12V 2kW DIESEL HEATER DOES NOT IMMEDIATELY SHUT-OFF. THIS IS NORMAL, NOT A FAULT.***

***IT TAKES 3-5 MINUTES TO COOL DOWN / SLOW DOWN. THIS IS TO PROTECT THE FAN MOTOR.***

1300 663 868 | [enquiries@aussietraveller.com.au](mailto:enquiries@aussietraveller.com.au) | [aussietraveller.com.au](http://aussietraveller.com.au)

BRISBANE SHOWROOM: 11-15 Oasis Court, Clontarf QLD 4019 | MELBOURNE SHOWROOM: 235 Barry Road, Campbellfield VIC 3061



More information <https://www.caravansplus.com.au>

## WARRANTY STATEMENT

Aussie Traveller Pty Ltd ACN 642 775 460 (**Aussie Traveller**) offers the following warranty in relation to the products it supplies directly or through an authorised manufacturer, dealer or approved service repair agent (**Product**).

### Australian Consumer Law

The benefits of this warranty are in addition to any rights and remedies imposed by Australian State and Federal legislation that cannot be excluded. Nothing in this warranty is to be interpreted as excluding, restricting or modifying any State or Federal legislation applicable to the supply of goods and services which cannot be excluded, restricted or modified.

If you are a consumer as defined in the Australian Consumer Law: *Our goods come with guarantees that cannot be excluded under the Australian Consumer Law. You are entitled to a replacement or refund for a major failure and compensation for any other reasonably foreseeable loss or damage. You are also entitled to have the goods repaired or replaced if the goods fail to be of acceptable quality and the failure does not amount to a major failure.*

### Warranty

Aussie Traveller warrants that, subject to the exclusions and limitations below, all parts of the manufacture and assembly of the Product will be free from defects in materials and workmanship (**Warranty**) for a period of 12 months from the date of purchase as follows:

1. This Warranty is activated at the time of purchase by the final retail customer (being the owner of the Product).
2. In the event the Product is purchased by a manufacturer, dealer or approved service repair agent, this Warranty will commence at the time the final retail customer makes payment for the Product to the wholesale purchaser.
3. If the Product is purchased directly from Aussie Traveller for use by final retail customer and not to be on sold in any way, the Warranty will commence at the time of the original purchase.

### Warranty Period

This Warranty cannot be assigned or transferred to a subsequent owner of the Product.

The purchaser or final retail customer should inspect the Product immediately when received or at vehicle handover, to ensure that it appears free from any damage or defect, and matches the description provided.

If after accepting the Product, a defect appears in the manufacture or assembly of the Product before the end of the Warranty Period and Aussie Traveller finds the Product to be defective in materials or workmanship, Aussie Traveller will, in its sole discretion, either:

- a. replace, repair or refund the Product or the defective part of the Product free of charge; or
- b. cause the Product or the defective part of the Product to be replaced or repaired by a qualified repairer free of charge.

In arranging Warranty inspection, service and repair, Aussie Traveller will seek to provide the details of an approved service agent within your geographic area. Should one not be available, or if the Product is in use in travel, Aussie Traveller reserves the right to seek to arrange a repair or replacement at the next available location on the route of travel.

Aussie Traveller reserves the right to replace defective parts of the Product with parts and components of similar quality, grade and composition where an identical part or component is not available.

Products presented for repair may be replaced by refurbished goods of the same type rather than being repaired. Refurbished parts may be used to repair the Product.

### Aussie Traveller Awning Products

This Warranty covers specified defects in materials or workmanship for Awning Products as follows:

1. The vinyl fabric is warranted against:
  - a. holes caused by mildew (mildew will form on dust and dirt and stain fabric if fabric is not kept clean).
  - b. excessive cracking, peeling, hardening or loss of strength while used under normal conditions.
  - c. excessive fading (a slight colour change may occur due to ultraviolet rays).
2. All hardware components including the roller are warranted not to bend or break under normal use (excluding high winds, water pooling and accidents).

### Making a Warranty Claim

If a defect covered by this Warranty appears, the Customer must first contact Aussie Traveller within 7 days of first becoming aware of the defect. Aussie Traveller will assist the Customer to rectify and resolve any Product issue that may arise.

When making a claim under this Warranty, Aussie Traveller requires that the following information be provided before any further action will be taken.

1. Original Invoice (Document or Number);
2. Make and model of the Product;
3. Make and model of the vehicle (if Product fitted);
4. Vehicle build date (if Product fitted);
5. Vehicle chassis number;
6. Description of damage and/or repair required;
7. Photos of the damage and/or repair; and
8. Appropriate documentation (such as historical and maintenance records).

Aussie Traveller reserves the right to request more information or images should what is provided not be sufficient to make an assessment for the Warranty claim.

The Product must be made available to Aussie Traveller or its authorised repair agent for inspection and testing. If such inspection and testing find no defect in the Product, the final retail customer must pay Aussie Traveller's usual costs of service work and testing.

The final retail customer must bear the cost of the transport of the Product to and from Aussie Traveller or the authorised repair agent, and all insurance of the Product.

### **Exclusions**

This Warranty will not apply where:

- the Product has been repaired, altered or modified by someone other than Aussie Traveller, or without the written consent of Aussie Traveller or an authorised repair agent;
- the alleged defect in the Product is within acceptable industry tolerances and variances;
- Aussie Traveller cannot establish any fault in the Product after testing and inspection;
- the Product has been used other than for the purpose for which it was designed;
- the alleged defect in the Product has arisen due to the final retail customer's failure to properly use and maintain the Product in accordance with any of Aussie Traveller's instructions, recommendations and specifications (including applicable maintenance schedules);
- the alleged defect in the Product has arisen due to the final retail customer's request to customise the Product;
- the Product has been subject to abnormal conditions, including environment, temperature, high or excessive wind, water, fire, humidity, pressure, stress or similar;
- the alleged defect has arisen due to abuse, misuse, neglect or accident;
- unauthorised parts or accessories have been used on or in relation to the Product;
- the Product has been overloaded or involved in an accident;
- the alleged damage or defect has been caused by normal wear and tear;
- the alleged damage to fabric has been caused by storm, wind or rain, or stretching of fabric caused by water pooling on fabric;
- breakage or bending of hardware components has been caused by storm, wind or rain, or water pooling on fabric.

### **Replacement Warranty Item**

If, under Warranty, a Product is replaced or repaired by Aussie Traveller or an Aussie Traveller agent, unless provided in writing to indicate otherwise, the replacement Product will carry the **remaining** Warranty terms and conditions, including length of time, of the original purchased Product.

### **Change of Mind**

Aussie Traveller understands that at times, final retail customers may change their mind. Choose carefully as return and credit requests for items purchased by mistake or "change of mind" reasons may not be approved. Aussie Traveller will not accept Product returns under these circumstances unless by written approval by an authorized Aussie Traveller representative. If approved, an administration and restocking fee may apply.

### **Limitations**

Aussie Traveller makes no express warranties or representations other than set out in this Warranty.

The repair or replacement of the Product or part of the Product is the absolute limit of Aussie Traveller's liability under this express Warranty.

### **Contact**

**Australia Wide:** 1300 663 868

#### **Melbourne Office**

235 Barry Road  
Campbellfield, Melbourne, 3061  
Ph: +61 3 9357 6565  
enquiries@aussietraveller.com.au

#### **Brisbane Head Office, Factory & Showroom**

11-15 Oasis Court  
Clontarf, Brisbane, 4019  
Ph: +61 7 3284 3284  
enquiries@aussietraveller.com.au

To receive a copy of the Aussie Traveller Warranty Terms & Conditions or information regarding specific Aussie Traveller products, please contact Aussie Traveller Head Office on (07) 3284 3284 or email enquiries@aussietraveller.com.au.

1300 663 868 | [enquiries@aussietraveller.com.au](mailto:enquiries@aussietraveller.com.au) | [aussietraveller.com.au](http://aussietraveller.com.au)

BRISBANE SHOWROOM: 11-15 Oasis Court, Clontarf QLD 4019 | MELBOURNE SHOWROOM: 235 Barry Road, Campbellfield VIC 3061

