



Electric Floor Fryers

Model: 177EF40B, 177EF40C, 177EF40D, 177EF40E

02/2022

Please read and keep these instructions. Indoor use only.

1. General Information

1.1 Information about the instruction manual

This instruction manual contains information about the installation, operation and maintenance of the device and should be consulted as an important source of information and reference guide.

Awareness of the safety instructions and instructions for use in this manual will ensure the safe and correct use of the device. In addition to the information given here, you should comply with any local Health and safety Controls and generally applicable safety regulations.

The instruction manual forms part of the product and should be kept near the device and easily accessible for anyone carrying out the installation, servicing, maintenance or cleaning.

1.2 Key to symbols

In this manual, symbols are used to highlight important safety instructions and any advice relating to the device. The instructions should be followed very carefully to avoid any risk of accident, personal injury or material damage.



WARNING!

This symbol highlights hazards, which could lead to injury. Please follow the instructions very carefully and proceed with particular attention in these cases.



WARNING! Electrical hazard!

This symbol draws attention to potential electrical hazards. If you do not follow the safety instructions, you may risk injury or death.



CAUTION!

This symbol highlights instructions, which should be followed to avoid any risk of damage, malfunctioning and/or breakdown of the device.



NOTE! This symbol highlights tips and information, which have to be followed for an efficient and trouble-free operation of the device.



WARNING! Hot surface! This symbol is a warning that the device surface is hot when in use. Ignoring this warning may result in burns!

2. Safety

This section provides an overview of all important safety aspects.



In addition every chapter provides precise safety advice for the prevention of dangers which are highlighted by the use of the above mentioned symbols. Furthermore, attention should be paid to all pictograms, markers and labels on the device, which must be kept in a permanent state of legibility. By following all the important safety advice you gain an optimal protection against all hazards as well as the assurance of a safe and trouble-free operation.

2.1 General information

This device is designed in accordance with the presently applicable technological standards. However, the device can pose a danger if handled improperly and inappropriately.

Knowing the contents of the instruction manual as well as avoiding mistakes and thus operating this device safely and in a fault-free manner is very essential to protect yourselves from the hazards.

To prevent hazards and to ensure optimum efficiency, no modifications or alterations to the device that are not explicitly approved by the manufacturer may be undertaken. This device may only be operated in technically proper and safe condition.

2.2 Safety instructions for use of the device

If the device is used commercially, the user is obliged to ensure that the said industrial safety measures concur with the state of the rules and regulations applicable at the time in question for the entire period of use of the device and to comply with the new specifications.

The industrial safety laws applicable at the place of installation of the device and the regional territorial provisions must be complied with. Besides the industrial safety instructions in the instruction manual, the general safety and accident prevention regulations as well as environment protection regulations applicable for area of application of the device must be followed and complied with.

- o Please keep these instructions and give them to future owners of the device.
- o All people using the device should follow the instructions and tips contained in these instructions.
- o Only use the device indoors.

2.3 Intended use

Safe operation is only guaranteed when using the device for its intended purpose.

Any technical interventions, as well as assembly and maintenance are to be made by a qualified customer service only. The deep fat fryer is designed for the frying of appropriate foods only. You may not use the deep fat fryer for the following:

- o Heating of foods and liquids (fluids).

General Information

CAUTION

Any use going beyond the intended purpose and/or any different use of the device is forbidden and is not considered as conventional. Any claims against the manufacturer or his authorized representative as a consequence of experiencing damages resulting from unconventional use are impossible. The operator is liable for all damages resulting from inappropriate use.

NOTICE

This equipment must be installed in accordance with the appropriate national and local codes of the country and/or region in which the appliance is installed.

Improper installation, adjustment, maintenance or service, and unauthorized alterations or modifications can cause property damage, injury, or death. Read the installation, operating and service instructions thoroughly before installing or servicing this equipment

WARNING

NEVER set a complete block of solid shortening on top of heating elements. To do so will damage the elements and increase the potential for flash-point shortening temperatures and might cause fire.

3. Transport, packaging and storage

3.1 Delivery check

Please check the delivery immediately after receipt. In case of visible damage do not accept.

Note the extent of damage on the carrier's bill of delivery. Trigger off the complaint. Hidden damages should be reclaimed immediately after notice, as claims for damages can only be asserted within the effective period for complaints.

3.2 Packaging

Please do not throw away the covering carton of your device as it might be useful for storage purposes, when moving or, in case of damages, when the device must be sent back to a repair center. The outer and inner packing material should be removed completely from the device before installation.

NOTE! If you liked to dispose the packing, consider the regulations applicable in your country. Supply re-usable packing materials to the recycling.

3.3 Storage

Keep the package closed until installation and under consideration of the outside indicated positioning-and storage markings. Packages should be stored under consideration of the following:

3.4 Scope of delivery

The scope of delivery includes the following parts and assembly units:

- Baskets*2
- Mesh support*1
- Drain extension*1
- Leg*4

Please inspect the device upon completeness. In case any part is missing please contact our customer service center immediately.

4. Technical data

4.1 Technical specification

Electric Floor Fryers

Model	Power	Voltage (V)	Phase	Wire	Amps
EF20-240-1	14kw	240V	1	3	59
EF20-240-3	14kw	240V	3	4	34
EF20-208-1	12kw	208V	1	3	58
EF20-208-3	12kw	208V	3	4	34

4.2 Parts Diagram

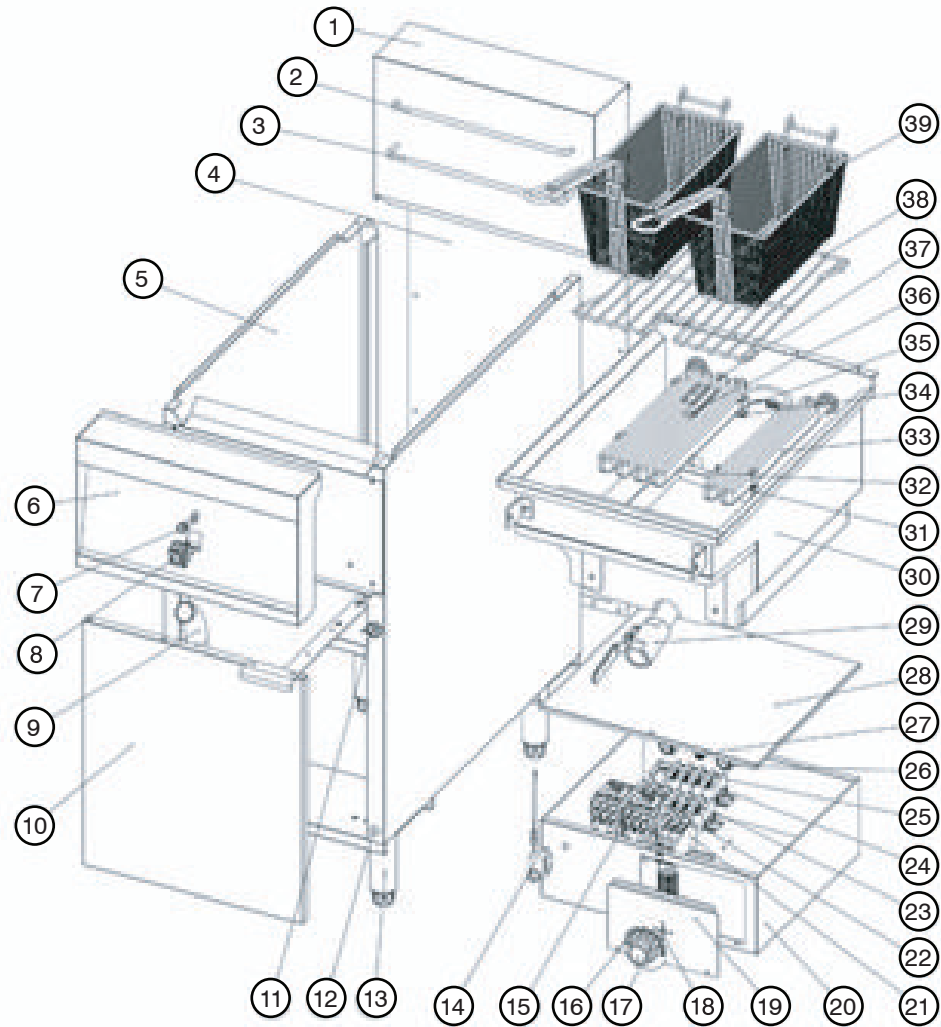

	Description	Spec	Part Code	Unit QTY
1	Rear coaming assy	SS430 1.0mm	-----	1
2	Basket hanger	SS430 1.5mm	-----	1
3	Top basket hanging rod	Nickel coating	70201107219L	1
4	Bottom basket hanging rod	Nickel coating	70201107228L	1
5	Frame assy	-----	-----	1
6	Front decoration plate	SS430 1.0mm	-----	1
7	Working indicator	ADP-24 230V YELLOW	70101301628L	1
8	Power switch	SR-13	70100800682	1
9	Oil drain extension pipe	1" Aluminized pipe	70202018273	1
10	Door assy	-----	-----	1
11	Door magnet	-----	70201900019	1
12	Door column	φ14.3*12	70200202737	1
13	Adjustable leg	SS 6"	70200900019	4
14	Temperature limiter	230°C	70100300964	1
15	Electromagnetic contactor	40A	70100901264L	1
16	Dial plate	-----	-----	1
17	Control knob	-----	70101100273	1
18	Thermostat	190°C	70100301519	1
19	Thermostat mounting plate	-----	-----	1
20	Electrical box	-----	-----	1
21	Fuse holder	-----	70101301719L	1
22	Fuse	10A	70101301728L	2
23	Six-terminal block	60A	70100702864L	1
24	Four-terminal block	100A	70100702873L	1
25	Power cord bracket	ØPG36	70100700773	1
26	Connector	S-FZS26-26	70202015882	4
27	Power cord sheath	SB-16	70100701855	1
28	Electical box cover plate	-----	-----	1
29	Drain valve	1"	70200500746	1
30	Oil tank assy	SS439 1.5mm	-----	1
31	Heater supporting plate	-----	-----	2
32	Heater connecting plate B	245*16*2mm	-----	1
33a	Heating Element	240V/14KW	70100410473L	1
33b	Heating Element	208V/12KW	70100410737L	1
34	Heater connecting plate A	128*16*2mm	-----	1
35	Heater fixationplate	-----	-----	4
36	Hi-limit sensor fixation plate	-----	-----	1
37	Temp. sensor fixation plate	-----	-----	1
38	Basket mesh	311*342mm iron nickel coating	70201107200L	1
39	Basket	Q235 Nickel coating, green handle	70201105228	2

5. Installation and operation

5.1 Safety instructions



WARNING! Risk of electric shock!

All wiring connections for this appliance must be made in accordance with the wiring diagram(s) furnished with the appliance. Refer to the wiring diagram(s) affixed to the inside of the appliance door when installing or servicing this equipment.

Never allow the power cable to come into contact with heat sources or sharp edges. The power cable should not hang over the side of the working surface. Ensure that no one can step on or trip over the cable. The power cable must not be folded, bent or tangled, and must always remain fully unrolled. Never place the device or other objects on the power cable. Do not lay the cable over carpets or heat insulations. Do not cover the cable. Keep away the cable from operating range and do not dunk it into water. Do not use the device in case it does not function properly, has been damaged or dropped. Do not use any accessory or spare parts that have not been recommended by the manufacturer. These can be dangerous for the user or lead to damages of the device or personal injury, and further, the warranty expires. Do not move or tilt the device when in operation. During operation of the unit your hands, the ON/OFF switch must be dry. Do not leave the unit unattended during operation since there might occur malfunctions which could result in overheating of the oil (fat). In case of high temperatures oil (fat) might ignite. You may not use moisten frying goods. Always remove the extra ice from deep frozen goods first. Even the smallest water drops may cause oil splashes or lead to explosions during frying.



NOTE! Overly wet foodstuffs or too large a quantity of food causes excessive foaming of oil during frying. Do not leave any frying goods in the basket hanging over the container with the hot oil. The fryer may not be moved or repositioned as long as the oil is hot. The oil must cool down first. Risk of injury! Hot oil splashes and fat explosions respectively may cause burns at hands and face!

5.2 Installation and connection



CAUTION! The device **MUST** be installed by a qualified specialist only.

Discard the complete packing material after unpacking the device. Place the device on top of a solid, even, safe and stable surface that tolerates the weight. Not at any time you should place the device on top of an inflammable surface (such as: table cloth, carpet, etc.). You must not position the device near open fireplaces, electric ovens/arc furnaces, furnaces/electric heaters or other heat sources.

Avoid installation spots with close contact to water. Remove the lid, basket, handle and other accessories from the device. Do not allow grease to accumulate or harden on the frame or body of the fryer. Clean the fryer inside and out with a solution of detergent and hot water daily. Dry the unit thoroughly!



WARNING! Hazard via electrical current!

The device can cause injuries due to improper installation! Before installation the local power grid specification should be compared with that of the device (see type label).

Connect the device only in case of compliance!
Take note of the security advice!

5.3 Operation



CAUTION! The operation of the device may only be carried out by personnel that have been instructed in operation of the device and the special hazards of frying.

There is an orange heating indicator light on the front panel. The heating indicator would cycle on and off to keep the set temperature. The on/off switch controls the power supply.



Ensure that the device is switched off (Temperature control toggle is in position "0"). There may be no oil at all in the oil container before filling it with oil. The oil container must be clean and dry. The oil drainage valve must be closed. Carefully fill the oil frypot with oil up to the required level (between „MIN“-and „MAX“-marking in the container). Markings are at the back part of the frypot.



CAUTION!
Do not use the device without having frying oil in the oil container. Make sure the oil level is always between „MIN“-and „MAX“-marking of the oil container.



WARNING!
Danger of fire! When the oil level goes below the minimum marked MIN, there is an increased risk of oil catching fire. Danger of burns! When the oil level is above the maximum marked MAX, hot oil may spill out.



CAUTION!
Use liquid fat for frying only. Solid frying fat (block or brick grease) should be removed preliminary!



WARNING!
Danger of burns! Do not use stale oil for frying, as a lower combustion temperature may cause the oil to foam and ignite easily. It also emits more smoke and odor.

Change frying oil regularly. Stale oil, after cooling, should be carefully poured into a container and disposed of in accordance with environmental regulations. Connect the drain extension to the drain valve. Put an empty container underneath the drain extension pipe. To drain oil from the frypot, grasp the drain valve handle on the drainage valve and rotate the handle. Switch the device on by means of the ON/OFF switch. The green power control lamp flashes up. Set the temperature control clockwise to the desired temperature 120°F (49°C) and 374°F (190°C). The orange heating control lamp flashes up during the heating process and extinguishes after the adjusted temperature has been reached. The fryer is equipped with a thermostat for temperature regulation. Once the temperature in the oil container decreases the device initiates the heating process and the orange heating control lamp flashes up.



WARNING! Danger of burn! During the work, chips and oil in the oil container become very hot and there is a danger of catching fire. Rotate the thermostat back to starting position and turn off the main on/off switch as soon as the deep-frying process is finished and the device is not being used.

o For best results you should wait until the desired temperature has been reached before placing the frying goods in the fryer.

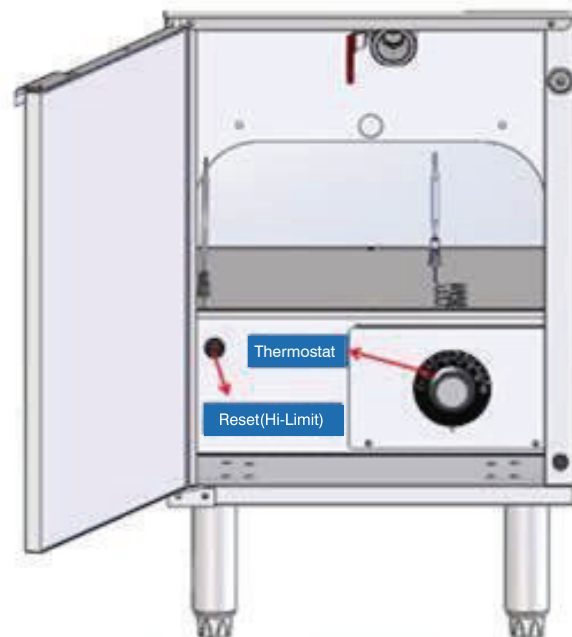

Slowly dip the basket into the oil. After frying is finished, carefully lift the basket, hang it on the basket hanger and leave the basket to drip.



WARNING! Risk of injury! There is optional fryer frypot lid. The standard product does not ship with lid. The fryer may not be operated with the lid (cover)! The cover may be used for reasons of dust protection or when keeping warm foods only. In order to avoid dangerous fat splashes caused by water dripping from the cover you ought to make sure it is dry before setting it on top.

In case you accidentally engaged the fryer without having frying oil in the oil container or without having inserted the minimum amount of oil, the device automatically shuts down at a temperature of 446°F (230 °C) in order to protect itself from overheating. Whenever this occurs, switch off the device, shut off the main power supply and let the device cool down. After the device has been switched off by the heat protection switch, it can only be restarted by pressing the RESET-button in the bottom cabinet. RESET-button For this purpose, cool the unit to below 338°F (170 °C) , then unscrew the plastic shield by turning the RESET button counter clockwise, press the red plastic pin and again turn the plastic shield clockwise. Now you may turn on the power supply and engage the device to proceed as normal.

6. Cleaning and maintenance

6.1 Safety advice

Before beginning with repair or cleaning works make sure the device has been disconnected from power supply and has cooled down. Do not use any acid agents and make sure no water ingresses the device. To protect yourself from electric shock, never immerse the device, its cables in water or other liquids.



CAUTION!
The device is not suited for direct washing via water jets. Therefore, you must not use any kind of pressure water jet for cleaning the device!

6.2 Cleaning

The device should be cleaned regularly.

Clean the frypot at least once each week by filling it to just below the upper oil level mark with water. Add one cup of detergent and boil the water. Allow the solution to simmer for 10-15 minutes, then drain and rinse the frypot with clean water twice. Add ¼ cup of white vinegar to the last rinse to neutralize any alkalinity remaining from the detergent. Wipe the frypot surfaces with a dry towel before refilling with cooking oil. If the fryer is not to be used immediately after cleaning, it is suggested that the inside of the frypot be wiped down with a light coat of cooking oil to prevent rust.



CAUTION!
The switching unit (control panel) must not be washed wet or immersed in water. Moisture must not get inside the unit. Prior to using, dry all elements of the unit thoroughly!

Control panel, surface of the device and power cord should only be wiped off with a soft cloth and a mild cleaning agent. You must not let water enter the switching unit. This may lead to dangerous creeping current and malfunctions of the device.

Do not use any aggressive cleaning agents or abrasive materials as these could damage the fryer. Clean the device with a mild cleaning liquid. Heavily stained parts should be left for soaking.

All parts must be dried thoroughly. Reassemble the parts of device.

Store the device in a dry place when not using for longer periods. Keep it away from acid steams and gases.

-30 →

6.3 Safety instructions for maintenance

Inspect the power cable regularly for damage. Never use the device if the cable is damaged. If the power cable is damaged, have an authorized service center or qualified electrician replace it.

In case of damage or malfunction, please contact our customer service centre.

Only a qualified technician and using original spare parts and accessories should carry out repairs and maintenance of the device. Do not attempt to repair the device yourself.

7. Possible malfunctions

Problem	Cause	Removal
Unit is connected to a power source, green control light does not come on, unit does not heat up.	<ul style="list-style-type: none"> Blown fuse Switching unit is improperly installed Overheating protection has turned off Damaged temperature 	<ul style="list-style-type: none"> Remove plug insert properly Check fuses, connect unit to another socket Check location of the switching unit Press RESET on the switching unit
The orange heating control light comes on, the temperature does not increase.	<ul style="list-style-type: none"> Interrupted contact with heating element Damaged heating element 	<ul style="list-style-type: none"> Contact sales agent Contact sales agent
On/off power switch light comes on but the orange heating control light does not come on in spite of desired temperature being reached.	<ul style="list-style-type: none"> Set temperature has been reached Damaged temperature control 	<ul style="list-style-type: none"> Check functioning at different temperature Contact sales agent
Heating element ceases functioning after some time.	<ul style="list-style-type: none"> Overheating control has activated 	<ul style="list-style-type: none"> Press RESET on the switching unit

The previously mentioned trouble cases are just exemplary and to give you orientation. Should these or similar troubles occur, please switch off the device and stop use immediately. Contact qualified technicians or the manufacturer for inspection and repair.

8. Waste disposal

Discarding old devices



At the end of its service life the discarded device has to be disposed in accordance with the national regulations. It is advisable to contact a company which is specialized in waste disposal, or just contact the local disposal service in your community.



WARNING!

To exclude any abuse and the dangers involved make the waste device unfit for use before disposal. For that purpose disconnect device from mains supply and remove mains connection cable from the device.

NOTE! For the disposal of the device please consider and act according to the national and local rules and regulations.

Stale oil

Please remove used frying oil in accordance with all applicable environmental protection regulations.