



Intertek  
4009293



Intertek  
4009293

CONFORMS TO NSF STD. 8  
CONFORMS TO UL STD. 763  
CONFORMS TO CSA STD.C22.2 NO 195

## Gear Driven 40 Qt. Commercial Mixer

**Models:** 177MX40H

9/2022

***Please read and keep these instructions. Indoor use only.***

## Index

Safety instructions .....	3
Installation and cleaning .....	4
Removal and refitting instructions mixer safety guard.....	5
Parts overview .....	6
Operating instructions .....	7
Mixer capacity chart and Specifications .....	8
Accessories .....	9
Troubleshooting .....	10
Warranty information .....	11

## Important Safety Instructions

**When using electrical appliances, basic safety precautions should be followed, including the following:**

1. Read all instructions carefully and completely.
2. For commercial use only.
3. Protect against electrical shock by keeping all cords, plugs, and other electrical components away from water or other liquids.
4. Unplug this unit when not in use and before cleaning.
5. DO NOT operate this unit or any appliance with a damaged electrical cord or plug.
6. DO NOT operate this or any appliance after it has malfunctioned or has been damaged in any way.
7. DO NOT use outdoors.
8. Disconnect the unit by removing the electrical plug from the wall outlet.
9. DO NOT use appliance for any application other than its intended use.
10. DO NOT store any item on top of this unit when in operation.
11. DO NOT allow this unit to touch or to be covered by flammable material such as curtain, draperies, walls, etc., when in operation.
12. DO NOT clean with metal scouring pads, as pieces can break off and touch electrical components, heightening the risk of electrical shock.
13. Avoid scratching the surface or nicking the edges of this unit.
14. Turn off the appliance by removing the plug from wall outlet.
15. Note that the use of accessories not recommended by the manufacturer may result in injury.
16. Children should be supervised to ensure that they DO NOT play with the unit.
17. This appliance is not intended for use by persons (including children) with reduced physical sensory or mental capabilities, or lack of experience and knowledge, unless a person responsible for their safety has given them supervision or instruction concerning use of the appliance.

**NOTE: Save these instructions for future reference.**

## Installation

1. Prior to installation the electrical supply to the unit must be checked to ensure it complies to the electrical rating of the machine as detailed on the serial plate.
2. The unit must be positioned to ensure there is sufficient space around the machine to operate the controls and to raise and lower the mixing bowl. It is essential the unit is placed on a sturdy level surface.



### **WARNING:**

**The electrical cord on this machine is fitted with a three-pronged grounding plug which must be connected to properly grounded electrical outlet. If the outlet is not the proper grounding type contact an electrician. DO NOT remove the grounding prong from the plug!!!**  
**Electrical and grounding connections must comply with the applicable portion of the National Electrical Code and/or other local electrical codes.**

## Cleaning



### **WARNING: DISCONNECT THE MACHINE FROM THE POWER SOURCE BEFORE CLEANING**

All new mixer bowls and accessories including whips, beaters, and dough hooks should be properly washed before use.

Wash with hot water and a mild soap solution and then rinse off with either a mild vinegar or soda solution and then rinse again with clean water. It is highly recommended this cleaning procedure is followed for bowls and accessories prior to whipping egg whites or whole eggs. The mixer should be cleaned daily with a clean damp cloth.

If the unit has not been used for some time, it is recommended that the procedure above is followed before mixer use. It is important that the rear bowl lift guides are greased every three months to prevent corrosion.

### **NOTE!**

**The bowl safety guard is easily removable for cleaning. Please see specific instructions on page 5.**

## REMOVAL AND REFITTING INSTRUCTIONS MIXER SAFETY GUARD

1. To remove the wire guard adjust the position to align the edge of the wire guard with the single indentation marker on the fixed rear guard. See figure 1.



Figure 1

2. Remove the rubber closing caps from the mounting screws as in the indicated positions. Remove the screws. See figure 2 and 3.

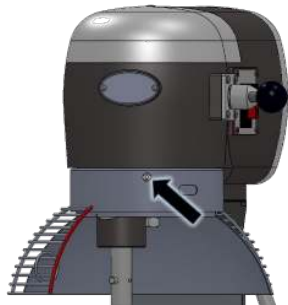

Figure 2

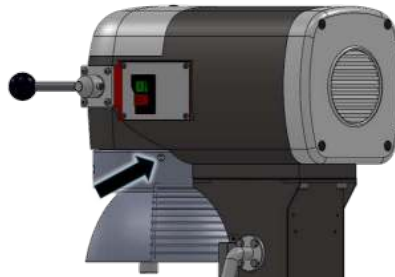

Figure 3

3. Turn the wire guard until the edge of the wire aligns with two indentation markers on the fixed rear guard. See figure 4.

4. Remove the cap and mounting screw in the indicated position. See figure 5.

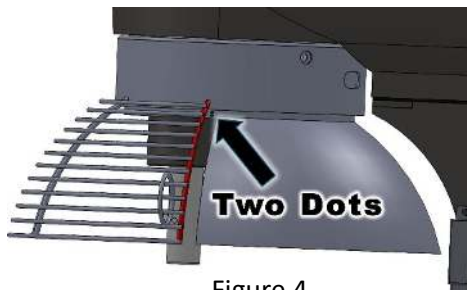

Figure 4

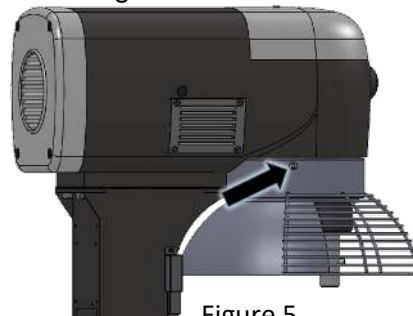

Figure 5

5. Ensure that all rubber caps are fitted properly into the screw heads. See figure 6.

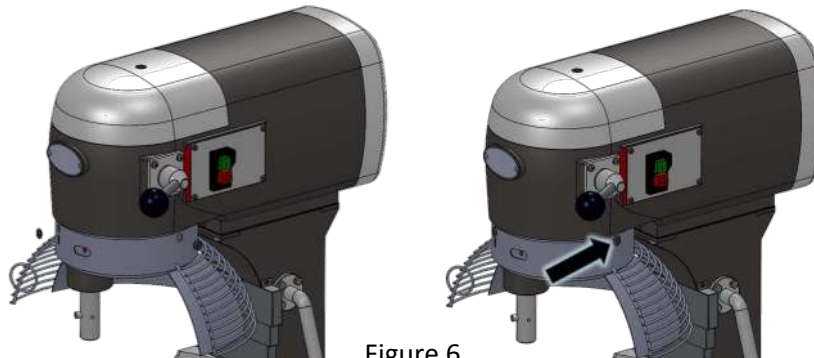
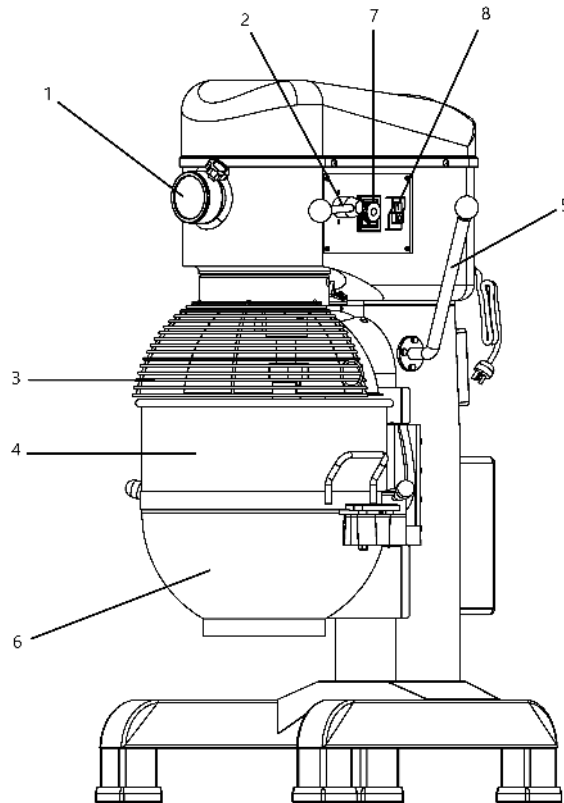

Figure 6

6. To replace the wire guard after cleaning repeat the instructions above in reverse.

## Parts Overview

ITEM	DESCRIPTION
1	#12 Hub
2	Mixing Speed Handle
3	Safety Guard
4	Mixing Device (Not shown in drawing)
5	Bowl Lift Handle
6	Bowl
7	Timer
8	Power Switch



### Notes:

- Do not hose down mixer.
- Do not operate the mixer with wet hands.
- Unplug mixer from electrical supply prior to any maintenance or repairs.

## Operating Instructions for Normal Using

- 1 Set the timer #7 to the desired operating time between 1-30 minutes. The timer does not require adjustment for every cycle and will default to the pre-set time until changed by the operator.
- 2 Close the safety guard #3. The unit will not operate if this guard, the bowl #6, and the bowl lift handle #5 are in the incorrect position.
- 3 Set the desired mixing speed using the handle #2, suitable for the attachment fitted and the product being processed. Please refer to the mixing speed chart on page 8.
- 4 After the speed has been selected press the ON button #8. The unit will now run for the timed period set and then switch OFF automatically.
- 5 The red emergency stop button if operated will shut down the machine at any time during the time cycle.

**ALWAYS TURN OFF THE MACHINE BEFORE CHANGING SPEEDS. FAILURE TO DO SO MAY DAMAGE THE GEARBOX AND VOID THE WARRANTY.**

**ALSO MAKE SURE THAT THE BOWL IS IN THE FULLY LIFTED POSITION AND THE SAFETY AND THE SAFETY GUARD IS CLOSED.**

Low speed is position #1 and the knob will be facing forwards.

Medium speed is position #2 and the knob will be facing up.

High speed is position #3 and the knob will be facing down.

**ALWAYS USE THE CORRECT ATTACHMENT FOR THE JOB.**

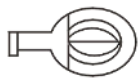

- A. **Whisk:** Suitable for mixing liquids and soft ingredients, can work in all speeds. Do not run for more than 15 minutes.



- B. **Flat Beater:** Suitable for mixing dry ingredients, can work in low & medium speeds only. Do not use in high speed. Do not run for more than 15 minutes.



- C. **Dough Hook:** Suitable for mixing dough, can work in low speed only. Do not use in high speed. Do not run for more than 20 minutes. Absorption ratio must be more than 50%. Refer to mixer capacity chart.

## Using The Attachment Hub

1. Turn the mixer off and remove any agitator attachment.
2. Loosen the hub mounting screw and remove the attachment hub cover.
3. Insert and align the attachment shaft into the attachment hub, ensure that the attachment is fully inserted.
4. Tighten the hub mounting screw.



**NEVER RUN THE MIXER WITH HUB ACCESSORY AND AGITATOR AT THE SAME TIME**

## Mixer Capacity Chart

Product	Agitator and Speed	Maximum Bowl Capacity
Bread and Roll Dough -60 % AR	Dough Hook - 1st only	30 lb
Heavy Bread Dough -55% AR	Dough Hook - 1st only	25 lb
Pizza Dough, Thin -40% AR	Not Recommended	15 lb
Pizza Dough, Medium -50% AR	Not Recommended	20 lb
Pizza Dough, Thick -60% AR	Not Recommended	30 lb
Raised Donut Dough -65% AR	Dough Hook - 1st only	17.5 lb
Mashed Potatoes	Flat Beater	20 lb
Waffle or Hot Cake Batter	Flat Beater	15 qt
Egg Whites	Wire Whisk	1.75 qt
Whipped Cream	Wire Whisk	4 qt
Cake Batter	Flat Beater	25 lb

When mixing dough ( pizza, bread or bagels), check your "AR" absorption ratio - water weight divided by flour weight. Above capacities based on 12% flour moisture at 70°F water temperature. If high gluten flour is used, reduce above dough batch size by 10%.

**Example:** If recipe calls for 5 lb. of water and 10 lb. of flour, then 5 divided by 10 = 0.50 x 100 = 50 %AR.





- 2nd Speed should never be used on mixtures with less than 50% AR.

When calculating the correct size mixer for your application, here are some helpful weights & measures:

- 8.3 lb. = 1 gallon of water – 2.08 lb. = 1 Quart.

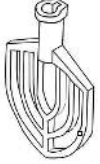
TYPE		177MX40H
Capacity		40 qt
Power Supply (V)		240V ~60Hz
Power (W)		1300W
Amps		10A
Phase		1PH
Mixing Speed (R.P.M)	Whip	596
	Flat Beater	204
	Dough Hook	130
	Hub Attachment	58/90/263
Max Flour Capacity		25 lb
Horse Power		2 hp

## Standard Accessories

Item	Description	Part No.	Qty
	Flat Beater	177MX40BEAT	1
	Dough Hook	177MX40HOOK	1
	Whisk	177MX40WHISK	1
	Bowl	177MX40BOWL	1

## Optional Accessories

Item	Description	Part No.	Qty
	Ingredient Chute	177MX34CHUTE	1

### NOTES:

- Any agitator is easily installed by simply raising it onto the mixing axle, and the rotating it clockwise on the shaft until it locks into place. To remove, raise the agitator on the shaft until it clears the lock and then rotate counter-clockwise and lower.
- All of the accessories are precisely fitted to the bowl, have rounded corners, and are easily removable for cleaning.

## Troubleshooting

Trouble	Possible Causes	Solution
The axles can't work when operating the machine	Poor contact of the electrical equipment	Check the Plug
The mixing bowl is out of position	Moving direction is not correct	Change
Leaks oil	Sealing washer is damaged	Change
Difficult to move the bowl up and down	Slideway is rusted	Clean the slideway and lubricate
The motor is overheated and speed is down	The voltage is not enough, or incorrect speed	Check the voltage or use lower speed
Noise and overheating	Poor lubrication	Add or change lubrication
Mixer touches bowl	The mixing device or bowl deformed	Repair or change the bowl or mixing device
Mixer attachment stops	Thermal overloaded activated	Allow unit to cool down 30-60 minutes, reduce the batch size.

# Limited Warranty

---



Avantco Equipment warrants its equipment to be free from defects in material and workmanship for the prescribed time listed below, when purchased from an authorized dealer and appropriately installed in the United States. This is the sole and exclusive warranty made by Avantco covering your Avantco brand equipment. A claim under this warranty must be made within the prescribed time from the original date of delivery of the equipment. Claims under this warranty may only be made by the original purchaser. Avantco reserves the right to approve or deny the repair or replacement of any part or repair request. The warranty is not transferable. Coverage is determined at the time of sale and cannot be modified for previously purchased products.

## | 1 Year Replacement Warranty

This warranty applies to all Avantco Equipment products not specified below.

## | 2 Year Replacement Warranty

177MIX8 series countertop mixers only

## | 1 Year Parts and Labor Warranty

Avantco warrants the following models to be free of defects in material and workmanship for a period of 1 year when purchased from an authorized dealer and appropriately installed in the United States.

- 177MX series mixers 30 quarts and larger
- 177SL series automatic meat slicers
- 177EMBS94SS meat saw
- 177FBF flat bottom fryers
- 177EF40 electric floor fryers

## | Food Truck, Mobile, and Outdoor Commercial Use Warranty

Outdoor, mobile, and food truck customers shall receive 30 days of replacement warranty coverage for all equipment named above, regardless of the prescribed coverage period. To make a warranty claim, contact your authorized dealer.

## | Outside the Contiguous United States Warranty Information

Products sold into Alaska, Hawaii, other US territories outside of the Contiguous United States, and Canada shall be backed by replacement coverage on items that can ship via normal parcel shipping, excluding the cost of shipping and any applicable duties, taxes, and fees. Items that must ship LTL/common carrier will be provided replacement parts, excluding labor costs, or reimbursed in the form of store credit for the value of the item only, excluding all applicable shipping costs, duties, taxes, and fees, at the place of purchase following appropriate troubleshooting steps. The 30-day food truck, mobile, outdoor, and residential restrictions still apply.

# Limited Warranty

---



## | Coverage Limitations

This limited warranty does not cover:

- Equipment used for residential or non-commercial purposes.
- Equipment not purchased directly from an authorized dealer.
- Equipment where the serial number plate has been removed or altered.
- Equipment that has been altered, modified, or repaired by anyone other than an authorized service agency.
- Equipment that was not professionally installed, where applicable. Equipment requiring professional installation shall be named in its documentation and includes but is not limited to any equipment requiring a gas or plumbing connection. Proof of installation may be required to make a warranty claim.
- Damage or failure due to improper installation, improper utility connection or supply, use of unfiltered water (if applicable), and issues resulting from improper ventilation or airflow.
- Incidental or consequential damage of any kind.
- Defects and damage due to improper maintenance (such as rust), wear and tear, abuse, vandalism, or Act of God.
- Excessive use or use outside of the intended design of the equipment, such as use other than with foodstuffs or in excess of the manufacturer's recommendations as stated in the manual.
- Damage caused by improper electrical connection or voltage fluctuations.
- Avantco has the sole discretion on wearable parts not covered under warranty.

## | Warranty Inquiries and to Make a Claim

For all equipment covered by this replacement warranty, please contact your authorized dealer. Have your model number, serial number, and proof of purchase information ready.

### **www.WebstaurantStore.com**

Please use the online chat feature or email [help@webstaurantstore.com](mailto:help@webstaurantstore.com). You will need your order number to make an inquiry or claim.

### **The Restaurant Store**

Please contact your local store directly.

### **www.TheRestaurantStore.com**

Please use the online chat feature or email [help@therestaurantstore.com](mailto:help@therestaurantstore.com). You will need your order number to make an inquiry or claim.

### **Clark Food Service Equipment, PRO Marketplace, Hometown Provisions**

Please contact your account manager directly. If you do not know your account manager, please call 717-392-7363 for CFSE and Pro Marketplace or 717-464-4165 for Hometown Provisions.

For all equipment covered by this Service warranty, please contact Ready Kitchen Warranty via one of the below methods. You will need your model number, serial number, and original order number to make an inquiry or claim. Including pictures or video, as well as a description of the problem, will help to expedite claim processing time.

- **EMAIL** [help@ReadyKitchenWarranty.com](mailto:help@ReadyKitchenWarranty.com)
- **VISIT** the customer portal at [www.ReadyKitchenWarranty.com](http://www.ReadyKitchenWarranty.com)
- **CALL** 717-381-4844

This warranty is only valid for equipment purchased from an authorized dealer. A list of authorized dealers for your state can be found by going to [www.avantcoequipment.com](http://www.avantcoequipment.com)