



Adjustable Speed Conveyor Ovens

Models: 177CVROV10RA, 177CVROV10RB, 177CVROV10RD,
177CVROV14RB, 177CVROV14RD



Intertek
5009704
Conforms to
UL STD.197

Please read and keep these instructions. Indoor use only.

Index

Specifications 2
 Safety Information 3
 Circuit Diagram 4-5
 Installation 6
 Before Use 6
 Operation Instructions 6
 Specifications 6
 Cleaning & Maintenance 7

Specifications

Item #	Height	Width	Depth	Belt Width
177CNVYOV10RA	19.3"	17"	36.5"	10.5"
177CNVYOV10RB	19.3"	17"	36.5"	10.5"
177CNVYOV10RD	19.3"	17"	36.5"	10.5"
177CNVYOV14RB	19.3"	20"	36.5"	14"
177CNVYOV14RD	19.3"	20"	36.5"	14"

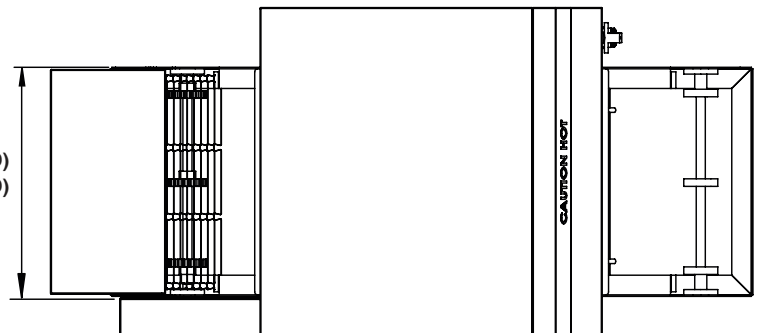
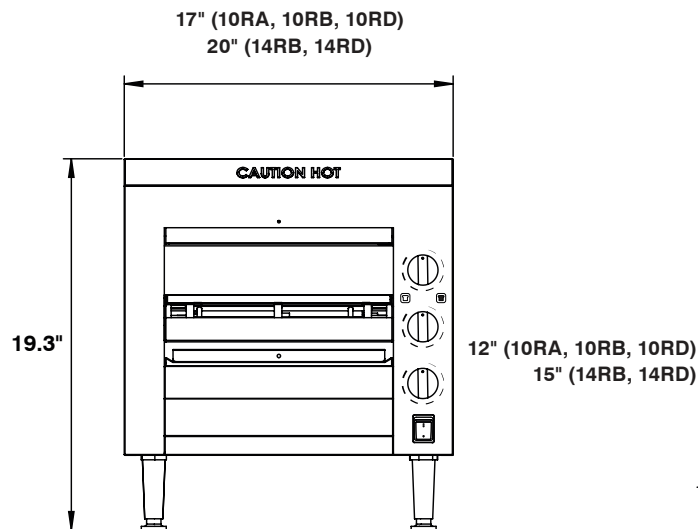
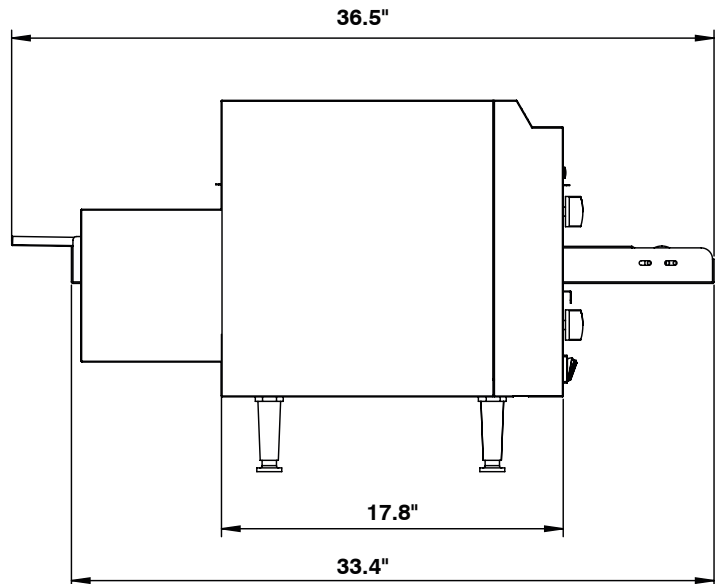

Important Safety Information

When using electrical appliances, basic safety precautions should always be followed, including the following:

1. Read all instructions carefully and completely.
2. For commercial use only.
3. DO NOT touch hot surfaces.
4. Protect against electrical shock by keeping all cords, plugs, and other electrical components away from water or other liquids.
5. Unplug this unit when not in use and before cleaning.
6. Allow the unit to cool before putting on or taking off parts.
7. DO NOT operate this or any appliance with a damaged electrical cord or plug.
8. DO NOT operate this or any appliance after it has malfunctioned or has been damaged in any way.
9. DO NOT use outdoors.
10. DO NOT place on or near a hot gas or electric burner.
11. DO NOT use appliance for any application other than intended use.
12. DO NOT insert metal utensils or oversized foods into this unit, as they may cause a fire and heighten the risk of electrical shock.
13. DO NOT store any item on top of this unit when in operation.
14. DO NOT allow this oven to touch or be covered by flammable material, such as curtains, draperies, walls, etc., when in operation.
15. DO NOT clean with metal scouring pads, as pieces can break off and touch electrical components, heightening the risk of electrical shock.
16. NEVER place materials such as paper, cardboard, plastic, etc. in this oven.
17. DO NOT cover interior of this unit with metal foil, as it may cause the oven to overheat.
18. Note that the use of accessories not recommended by the manufacturer may result in injury.
19. Children should be supervised to ensure that they DO NOT play with the oven.
20. This appliance is not intended for use by persons with reduced physical sensory or mental capabilities, or lack of experience and knowledge, unless a person responsible for their safety has given them supervision or instruction concerning use of the appliance.
21. When using the appliance in shops, snack bars, hotels etc., check the voltage and outlet to make sure the appliance is correctly connected with power.
22. Place unit on a flat surface that is well ventilated. The appliance must be supervised during operation. DO NOT leave appliance without powering off.

WARNING: Unit has a fan on bottom that is blocked if feet are not installed. Using the oven with no air flow will cause heating element and/or motor to fail.

Circuit Diagrams

177CVROV10RA

	Description
SW	Main Switch
E1 / E2	Top Element - 420W / 60V
E3 / E4	Bottom Element - 420W / 60V
M1	Conveyor Motor - 120V
CF	Cooling Fan - 120V
SC	Conveyor Speed Control
B1	Adjustable Thermostat - Top Elements
B2	Adjustable Thermostat - Bottom Elements

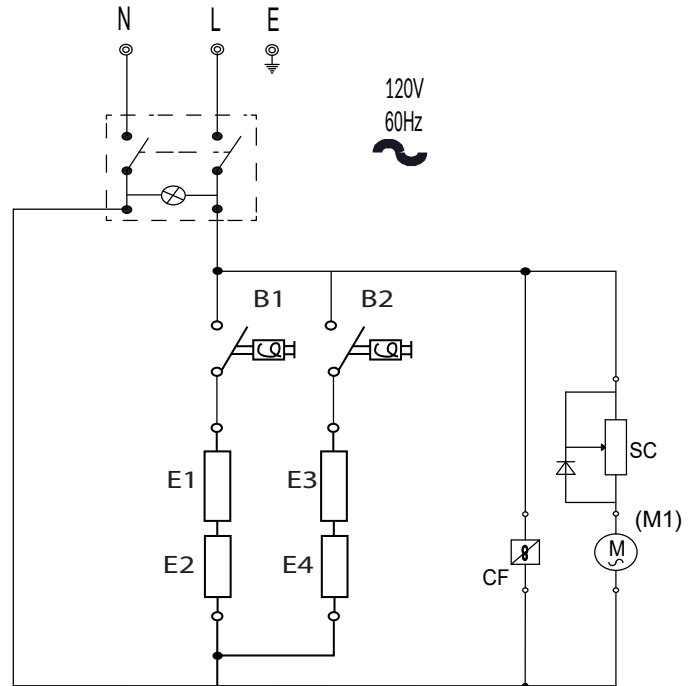

177CVROV10RB & 177CVROV10RD

	Description
SW	Main Switch
E1 / E2	Top Element - 700W / 100V (10B) or 700W / 120V (10D)
E3 / E4	Bottom Element - 700W / 100V (10B) or 700W / 120V (10D)
M1	Conveyor Motor - 240V
CF	Cooling Fan - 240V
SC	Conveyor Speed Control
B1	Adjustable Thermostat - Top Elements
B2	Adjustable Thermostat - Bottom Elements

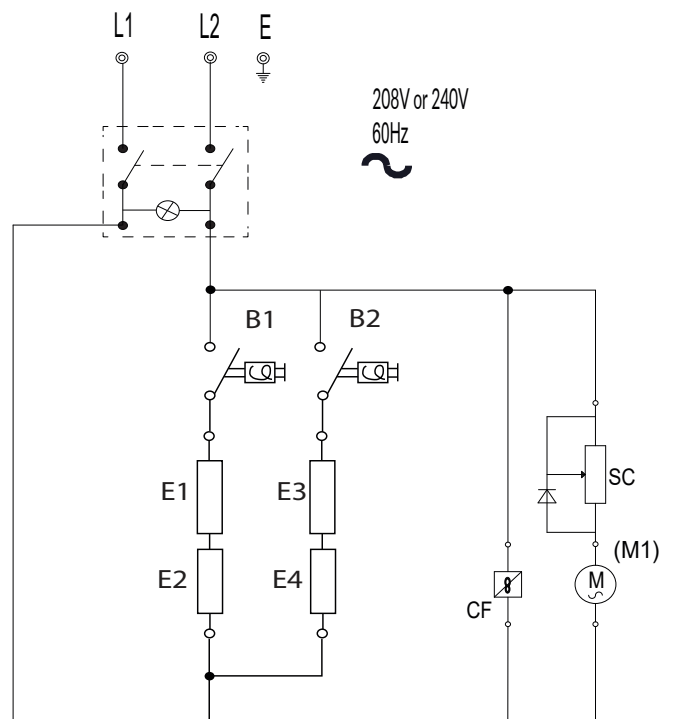

Circuit Diagrams

177CVROV14RB & 177CVROV14RD

	Description
SW	Main Switch
E1 / E2	Top Element - 875W / 100V (14B) or 900W / 120V (14D)
E3 / E4	Bottom Element - 875W / 100V (14B) or 900W / 120V (14D)
M1	Conveyor Motor - 240V
CF	Cooling Fan - 240V
SC	Conveyor Speed Control
B1	Adjustable Thermostat - Top Elements
B2	Adjustable Thermostat - Bottom Elements

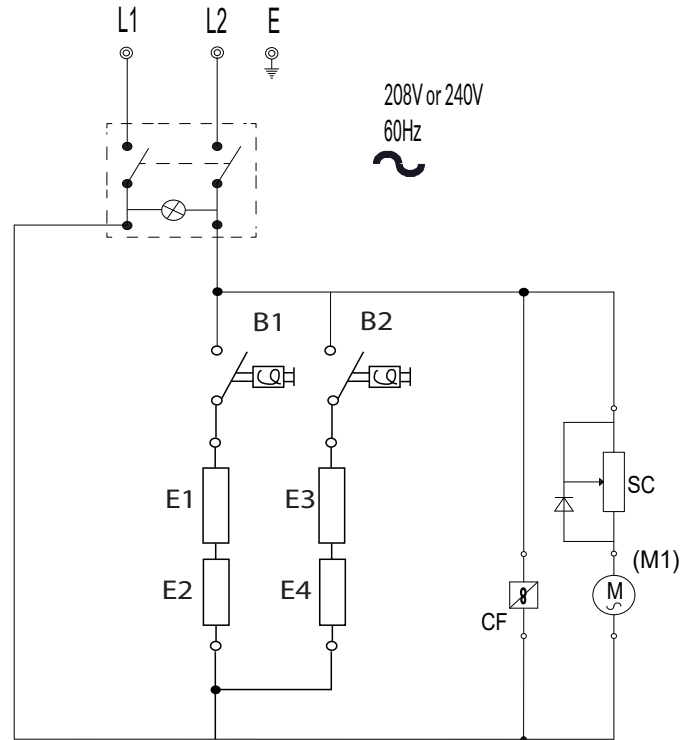

Installation

⚠ CAUTION ⚠

To reduce the risk of fire, the appliance is to be installed on a non-combustible surface and in non-combustible surroundings only, with no combustible material within 18" of the sides, front, or rear, or within 40" above the appliance.

NOTE: Model 177CVROV14RB is for use on an individual branch circuit ONLY.

Before Use

Before cooking anything in your oven for the first time, please follow these simple instructions:

1. The conveyor oven has been designed to toast sandwiches, melt cheese, and finish pizza/flatbreads.
2. It is intended for use in low to medium volume commercial establishments.
3. Ensure the support feet are assembled to the unit before commencing operation.
4. Thoroughly clean as described in the cleaning section (page 7) of this manual.
5. For best results, allow the unit to preheat for 20-25 minutes before use so that the correct operating temperature can be reached.

WARNING: Unit has a fan on bottom that is blocked if feet are not installed. Using the oven with no air flow will cause heating element and/or motor to fail.

Operation Instructions

Controls

The conveyor oven has three controls:

1. Conveyor Speed:
Determines the length of time the product is in the heating chamber.
2. The slower the speed, the longer the exposure and darker the product.
3. Top Heating Element Control:
1 is the lowest setting, 7 is the hottest setting.
4. Bottom Heating Element Control:
1 is the lowest setting, 7 is the hottest setting.

NOTE: The top and bottom heating elements are independently controlled

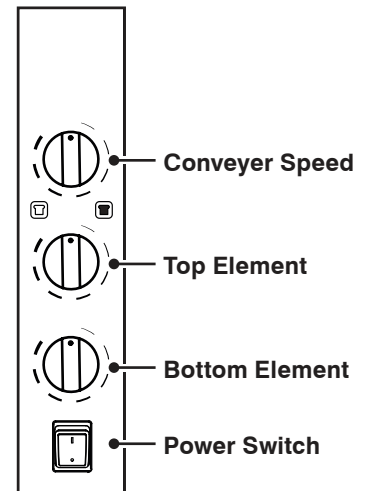

Testing the Unit

1. Test the control settings by placing a slice of bread in the oven. It can be placed directly onto the conveyor belt.
2. Observe the results and adjust setting to the desired temperature and conveyor speed. Product appearance or color will vary dependent on conveyor speed and temperature setting. Other factors that may affect the toasting color:
 - The moisture content of the product
 - The sugar content of the product
 - Initial product temperature

Cleaning & Maintenance

⚠ CAUTION ⚠

- **DO NOT immerse the appliance in water.**
- **ONLY USE a damp cloth or sponge dipped in soapy water.**
- **DO NOT use steel wool as it will damage the stainless steel finish.**

Exterior

1. Unplug the power cord from the wall outlet.
2. Wait for the oven to cool completely.
3. Wipe off the unit with a dry cloth and wait at least 30 minutes before reconnecting to the power outlet.

Crumb Tray

1. Unplug the power cord from the wall outlet.
2. Wait for the oven to cool completely.
3. Remove the crumb tray from the unit by pulling forward.
4. Dispose of the crumbs and clean the tray with a damp cloth or sponge dipped in soapy water.
5. Allow tray to dry.
6. Insert tray back into unit before using the conveyor oven.

Conveyor Belt

1. Turn off the toaster and allow unit to cool completely.
2. Turn the unit on and adjust the belt to slow speed and no heat.
3. To remove baked-on product, use an abrasive pad to wipe the conveyor belt side to side as it rotates.
4. For general cleaning, use a damp cloth to wipe the conveyor belt side to side as it rotates.