

Owner's Manual & Safety Instructions

Save This Manual Keep this manual for the safety warnings and precautions, assembly, operating, inspection, maintenance and cleaning procedures. Write the product's serial number in the back of the manual (or month and year of purchase if product has no number). Keep this manual and the receipt in a safe and dry place for future reference.

22j

AVANTI™

0.3MM GRAVITY FEED DUAL-ACTION AIRBRUSH



NOTICE

CLEAN IMMEDIATELY

Clean the Airbrush
IMMEDIATELY after use.

Delayed or inadequate cleaning will
permanently clog the Airbrush.

Visit our website at: <http://www.harborfreight.com>
Email our technical support at: productsupport@harborfreight.com

59292

When unpacking, make sure that the product is intact and undamaged. If any parts are missing or broken, please call 1-888-866-5797 as soon as possible.

Copyright© 2022 by Harbor Freight Tools®. All rights reserved.

No portion of this manual or any artwork contained herein may be reproduced in any shape or form without the express written consent of Harbor Freight Tools. Diagrams within this manual may not be drawn proportionally. Due to continuing improvements, actual product may differ slightly from the product described herein.

Tools required for assembly and service may not be included.

⚠ WARNING

Read this material before using this product.
Failure to do so can result in serious injury.
SAVE THIS MANUAL.

NOTICE
 Clean the Airbrush IMMEDIATELY after use.
 Delayed or inadequate cleaning will permanently clog the Airbrush.

Table of Contents

Safety	2	Maintenance	12
Specifications	6	Parts List and Diagrams	15
Setup	6	Warranty	16
Operation.....	7		



WARNING SYMBOLS AND DEFINITIONS	
	This is the safety alert symbol. It is used to alert you to potential personal injury hazards. Obey all safety messages that follow this symbol to avoid possible injury or death.
	Indicates a hazardous situation which, if not avoided, will result in death or serious injury.
	Indicates a hazardous situation which, if not avoided, could result in death or serious injury.
	Indicates a hazardous situation which, if not avoided, could result in minor or moderate injury.
	Addresses practices not related to personal injury.

IMPORTANT SAFETY INFORMATION

General Safety Warnings



WARNING Read all safety warnings and instructions.
Failure to follow the warnings and instructions may result in electric shock, fire and/or serious injury.
Save all warnings and instructions for future reference.

The warnings, precautions, and instructions discussed in this instruction manual cannot cover all possible conditions and situations that may occur. It must be understood by the operator that common sense and caution are factors which cannot be built into this product, but must be supplied by the operator.

1. **Work area safety**
 - a. **Keep work area clean and well lit.**
Cluttered or dark areas invite accidents.
 - b. **Do not operate the Compressor in explosive atmospheres, such as in the presence of flammable liquids, gases or dust.**
Compressor motors produce sparks which may ignite the dust or fumes.
 - c. **To reduce the risk of electric shock or injury, use indoors only.**
 - d. **Keep children and bystanders away from an operating compressor.**
2. **Electrical safety**
 - a. **Compressor plugs must match the outlet. Never modify the plug in any way. Do not use any adapter plugs with grounded compressors.** Standard plugs and matching outlets will reduce risk of electric shock.

NOTICE

Clean the Airbrush IMMEDIATELY after use.
Delayed or inadequate cleaning will permanently clog the Airbrush.

- b. **Do not expose compressor to rain or wet conditions.** Water entering a compressor will increase the risk of electric shock.
 - c. **Do not abuse the cord. Never use the cord for unplugging the compressor. Keep cord away from heat, oil, sharp edges or moving parts.** Damaged or entangled cords increase the risk of electric shock.
3. **Personal safety**
- a. **Stay alert, watch what you are doing and use common sense when operating this compressor. Do not use this compressor while you are tired or under the influence of drugs, alcohol or medication.** A moment of inattention while operating a compressor may result in serious personal injury.
 - b.  **Use safety equipment.** Wear protective paint spraying gloves and a NIOSH-approved respirator during use.
 - c.  **Always wear eye protection.** Wear ANSI-approved safety goggles.
 - d. **Prevent unintentional starting. Ensure the switch is in the off-position before connecting to power source or moving the compressor.**
4. **Compressor use and care**
- a. **To reduce the risk of electric shock, do not expose to rain.** Store indoors.
 - b. **Do not use the compressor if the switch does not turn it on and off.** Any compressor that cannot be controlled with the switch is dangerous and must be repaired.
 - c. **Disconnect the plug from the power source before making any adjustments, changing accessories, or storing the compressor.** Such preventive safety measures reduce the risk of starting the compressor accidentally.
 - d. **Store an idle compressor out of the reach of children and do not allow persons unfamiliar with the compressor or these instructions to operate it.** A compressor is dangerous in the hands of untrained users.
 - e. **Maintain the compressor. Keep the compressor clean for better and safer performance. Follow instructions for lubricating and changing accessories. Keep dry, clean and free from oil and grease. Check for misalignment or binding of moving parts, breakage of parts and any other condition that may affect the compressor's operation. If damaged, have the compressor repaired before use.** Many accidents are caused by a poorly maintained compressor.
 - f. **Use the compressor in accordance with these instructions, taking into account the working conditions and the work to be performed.** Use of the compressor for operations different from those intended could result in a hazardous situation.
5. **Service**
- a. **Have your compressor serviced by a qualified repair person using only identical replacement parts.** This will ensure that the safety of the compressor is maintained.

Specific Safety Warnings

1. **Risk of fire or explosion - do not spray flammable liquid in a confined area or towards a hot surface. Spray area must be well-ventilated. Do not smoke while spraying or spray where spark or flame is present. Arcing parts - keep compressor at least 20 feet away from explosive vapors, such as when spraying with a spray gun.**
2. **Risk of bursting - do not adjust regulator higher than marked maximum pressure of attachment.**
3. **Risk of injury - do not direct air stream at people or animals.**
4. **Do not use to supply breathing air.**
5. **Do not spray near open flames, pilot lights, stoves, heaters, the air compressor, or any other heat source. Most solvents and coatings are highly flammable, particularly when sprayed. Maintain a distance of at least 25 feet from the air compressor. If possible, locate the air compressor in a separate room.**

NOTICE

**Clean the Airbrush IMMEDIATELY after use.
Delayed or inadequate cleaning will permanently clog the Airbrush.**

6. Read all of the information concerning coating products and cleaning solvents.
Do not use chlorinated solvents (e.g. 1-1-1 trichloroethylene and dichloromethane, also known as methylene chloride) to clean spray guns. Many spray guns contain aluminum, which reacts strongly to chlorinated solvents. Contact the solvent or coating manufacturer as needed regarding potential chemical reactions.
7. Spraying hazardous materials may result in serious injury or death. Do not spray pesticide, acid, corrosive material, fertilizer, or toxic chemicals.
8. Paints and solvents may be harmful or fatal if swallowed or inhaled. Avoid prolonged skin contact with solvents or paints as they will irritate skin. After any contact, immediately wash off exposed area with hot, soapy water.
9. Air hose fittings may get hot during use. Allow fittings to cool before disconnecting.
10. **Do not leave compressor unattended for an extended period while plugged in. Unplug compressor after working.**
11. **Keep compressor well-ventilated. Do not cover compressor during use.**
12. Drain Tank daily and after use. Internal rust causes tank failure and explosion.
13. Do not remove the valve cover or adjust internal components.
14. Compressor head gets hot during operation. Do not touch it or allow children nearby during or immediately following operation.
15. Do not use the air hose to move the compressor.
16. The use of accessories or attachments not recommended by the manufacturer may result in a risk of injury to persons.
17. All air line components, including hoses, pipe, connectors, filters, etc., must be rated for a minimum working pressure of 150 PSI, or 150% of the maximum system pressure, whichever is greater.
18. USE OF AN EXTENSION CORD IS NOT RECOMMENDED. If you choose to use an extension cord, use the following guidelines:
 - a. Make sure your extension cord is in good condition.
 - b. Be sure to use an extension cord which is heavy enough to carry the current your product will draw. An undersized cord will cause a drop in line voltage resulting in loss of power and overheating. Table A shows the correct size to use depending on cord length and nameplate ampere rating. If in doubt, use the next heavier gauge. The smaller the gauge number, the heavier the cord.
19. Maintain labels and nameplates on the compressor. These carry important safety information. If unreadable or missing, contact Harbor Freight Tools for a replacement.
20. This product is not a toy. Keep it out of reach of children.
21. People with pacemakers should consult their physician(s) before use. Electromagnetic fields in close proximity to heart pacemaker could cause pacemaker interference or pacemaker failure.

NAMEPLATE AMPERES (at full load)	EXTENSION CORD LENGTH			
	25'	50'	10'	150'
0 – 6	18	16	16	14
6.1 – 10	18	16	Do not use.	
10.1 – 12	16	16	Do not use.	
12.1 – 16	14	12	Do not use.	







SAVE THESE INSTRUCTIONS.

NOTICE

Clean the Airbrush IMMEDIATELY after use.
Delayed or inadequate cleaning will permanently clog the Airbrush.

Symbol Definitions

PSI	Pounds per square inch of pressure
CFM	Cubic Feet per Minute flow
SCFM	Cubic Feet per Minute flow at standard conditions
NPT	National pipe thread, tapered
NPS	National pipe thread, straight

	WARNING marking concerning Risk of Eye Injury. Wear ANSI-approved eye protection.
	WARNING marking concerning Risk of Respiratory Injury. Wear NIOSH-approved respirator.
	WARNING marking concerning Risk of Explosion.
	WARNING marking concerning Risk of Fire.

NOTICE

Clean the Airbrush IMMEDIATELY after use.
Delayed or inadequate cleaning will permanently clog the Airbrush.

Specifications

Working Air Pressure	15-30 PSI
Air Inlet	1/8" Airbrush Hose (M10 x 1.0 thread)
Cup Capacity	0.3 oz
Nozzle/Needle Size	0.3mm

Setup - Before Use:



Read the **ENTIRE IMPORTANT SAFETY INFORMATION** section at the beginning of this manual including all text under subheadings therein before set up or use of this product.

WARNING

TO PREVENT SERIOUS INJURY FROM ACCIDENTAL OPERATION:
Turn the Power Switch "OFF" and unplug the Air Compressor from its electrical outlet before assembling or making any adjustments to the Air Compressor.

Note: For additional information regarding the parts listed in the following pages, refer to the Assembly Diagram near the end of this manual.

Components and Controls

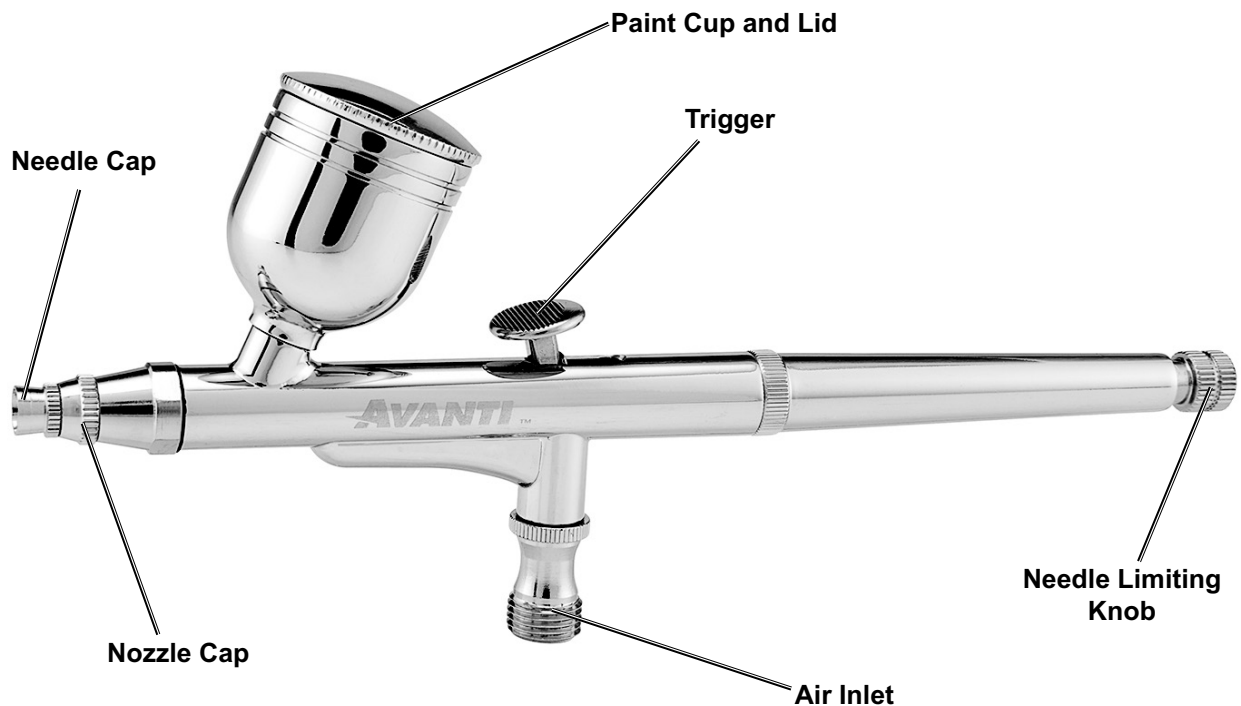

NOTICE

Clean the Airbrush IMMEDIATELY after use.
Delayed or inadequate cleaning will permanently clog the Airbrush.

Operating Instructions



Read the **ENTIRE IMPORTANT SAFETY INFORMATION** section at the beginning of this manual including all text under subheadings therein before set up or use of this product.

Work Area Set Up

1. Designate a work area that is clean and well-lit. The work area must not allow access by children or pets to prevent injury.
2. Locate the air compressor on a flat level surface to ensure proper pump lubrication and to prevent damage to the unit. Keep at least 12" of space around the unit to allow air circulation.
3. Route the power cord from the air compressor to the grounded wall outlet, along a safe path without creating a tripping hazard or exposing the power cord to possible damage.
4. Before spraying, mask nearby objects not being sprayed and lay cloths (not included) on the floors.

Air Connection Setup

1. Connect 1/8" airbrush hose (sold separately) to Air Inlet.
2. Connect air hose to air outlet on the compressor.
3. The air hose must be able to reach work area with enough extra length to allow free movement while working.

General Compressor Operation

1. Turn on air compressor according to air compressor instructions.
2. While the system is pressurized, check for air leaks by listening for air hissing and by feeling around connections. If a leak is detected, tighten connections. Do not use the air compressor unless all connections are air tight, the extra air leaking out will cause the air compressor to operate more often, increasing wear on the air compressor.



WARNING! TO PREVENT SERIOUS INJURY AND DEATH FROM EXPLOSION:

Do not adjust the internal pressure switch. Any change to the automatic pressure levels may cause excess pressure to accumulate, causing a hazardous situation.

NOTICE

Clean the Airbrush IMMEDIATELY after use.
Delayed or inadequate cleaning will permanently clog the Airbrush.

General Airbrush Operation

⚠ WARNING TO PREVENT SERIOUS INJURY: Do not adjust or tamper with any control or component in a way not specifically explained within this manual. Improper adjustment can result in tool failure or other serious hazards.

Risk of Fire or Explosion – Do not spray flammable liquid in a confined area. Spray area must be well ventilated. Do not smoke while spraying or spray where spark or flame is present. Keep compressor as far from spraying area as possible.

Paint Preparation and Filling

Note: Proper paint mixture is essential. Follow paint manufacturer's directions for thinning. Most paints will spray easily if they are thinned properly.

1. Thin the paint according to manufacturer's directions and mix thoroughly.
2. Carefully strain the paint through a paint strainer or a piece of cheesecloth.
3. Remove Lid from Paint Cup. Add paint to cup. Replace Lid.

4. Start the air compressor and set the regulator to needed pressure. **Do not exceed maximum air pressure.**
5. Test the consistency by spraying on a piece of scrap material.

If it still appears too thick, add a very small amount of thinner (not included) and mix thoroughly. Use the proper thinner for the type of paint. Thin CAUTIOUSLY. Proceed slowly, adding minimal amounts at a time. DO NOT exceed the manufacturer's thinning recommendations.

Flow Adjustment

1. **Needle Limiting Knob:**
 - a. Turn clockwise to reduce maximum paint flow. This is helpful when painting fine lines and detail work.
2. **Distance:** Move Airbrush closer to workpiece for thinner lines, move Airbrush away from workpiece for wider lines and a more blended look.

Note: Increase pressure for better paint atomization and blended looks. Reduce pressure to get less atomized paint with bigger droplets. Reduced pressure will also help the compressor performance.

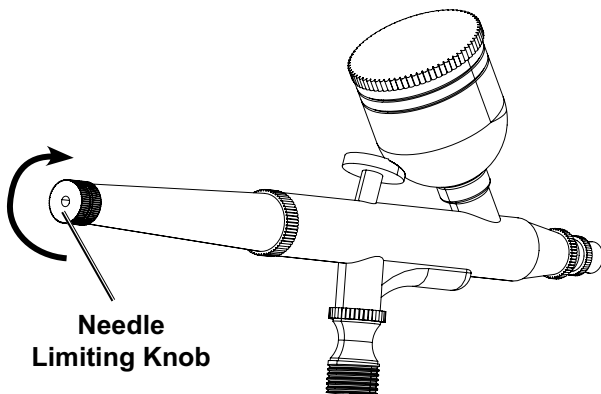

- b. Turn counterclockwise to increase paint flow.

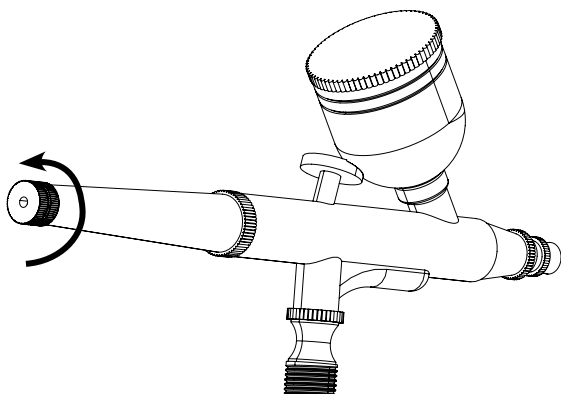

NOTICE

Clean the Airbrush IMMEDIATELY after use.
Delayed or inadequate cleaning will permanently clog the Airbrush.

Painting

Note: Practice painting techniques on scrap workpiece.

1. Plug air compressor into grounded 120VAC outlet. Turn air compressor on.
2. Press Trigger all the way down to start air flow, then adjust regulator between 20 - 30 PSI.

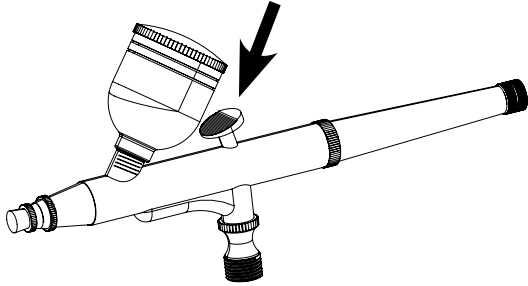

3. To avoid sputtering, press Trigger all the way down to start air flow, then pull Trigger back to start paint flow.
 - a. Pull Trigger all the way back for maximum paint flow.
 - b. Pull Trigger part-way back for less paint flow.

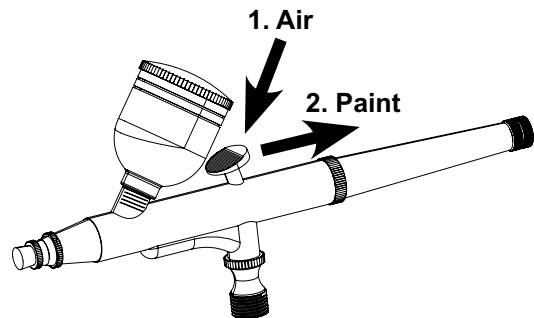

4. To avoid sputtering, when stopping, push Trigger forward to stop paint flow, then release Trigger to stop air flow.
5. When changing colors or clearing clogs, clean Airbrush according to **Clean During Use on page 10**.
7. When finished, clean Airbrush according to **Clean After Every Use on page 11**.
8. Turn off and unplug air compressor.
9. Bleed air pressure from Airbrush then disconnect Airbrush from air hose.
10. Store the Airbrush indoors out of children's reach.

NOTICE

Clean the Airbrush IMMEDIATELY after use.
Delayed or inadequate cleaning will permanently clog the Airbrush.

Cleaning



WARNING! TO PREVENT SERIOUS INJURY: TO PREVENT FIRE, IF A FLAMMABLE SOLVENT NEEDS TO BE USED, ADHERE TO THE FOLLOWING:

- a. Follow solvent manufacturer's clean up instructions and safety precautions.
- b. Flush Airbrush a full hose length from air compressor.
- c. If collecting flushed solvents in metal container, transfer to nonmetal container, and flush metal container.
- d. Work far away from any ignition sources in a vapor free area.
- e. Keep class ABC fire extinguisher nearby.

Solvent Selection

Follow paint and solvent manufacturer's recommendations for cleaning, solvent type, and disposal.

Clean During Use

1. Designate container or use Airbrush Cleaning Bottle (sold separately) for waste.
2. Have a clean, lint-free cloth and a cotton swab (sold separately) on hand.
3. Pour excess paint back into paint container.
4. Add solvent to Paint Cup, wipe with cotton swab to loosen paint still in Paint Cup.
5. Spray solvent into designated waste container, then spray on cloth until solvent runs clear.
6. Repeat adding solvent and spraying until solvent runs clear.
7. Resume painting.

NOTICE

Clean the Airbrush IMMEDIATELY after use.
Delayed or inadequate cleaning will permanently clog the Airbrush.

Clean After Every Use

1. Designate small container for cleaning parts.
2. Clean according to **Clean During Use on page 10**.
3. Turn off and unplug air compressor.
4. Bleed air pressure from Airbrush then disconnect Airbrush from air hose.
5. Disassemble Airbrush:
 - a. Remove Handle.
 - b. Loosen Needle Chucking Nut enough for Needle removal, but do not remove.
 - c. Carefully remove Needle, avoiding bending tip. Wipe Needle with paper towel wetted with solvent.
 - d. Remove Needle Cap and Nozzle Cap. Place parts in small container.
 - e. Carefully remove Nozzle with wrench. Place in small container.
 - f. Add solvent to small container to cover parts. Soak no longer than 10 minutes.
 - g. Use brush to clean parts and inside front of Airbrush.
 - h. Wipe exterior surfaces with paper towel wetted with solvent.
6. Make sure all parts are dry and free from residual paint, then reassemble Airbrush:
 - a. Replace Nozzle with wrench. Do not overtighten.
 - b. Replace Nozzle Cap and Needle Cap.
 - c. Inspect Needle to make sure tip is not bent, then carefully insert Needle straight into Needle Chucking Nut with gentle pressure until Needle stops.
 - d. Tighten Needle Chucking Nut completely, then pull Trigger to confirm Needle moves. If Needle does not move, tighten Needle Chucking Nut until Needle moves. Replace Handle.

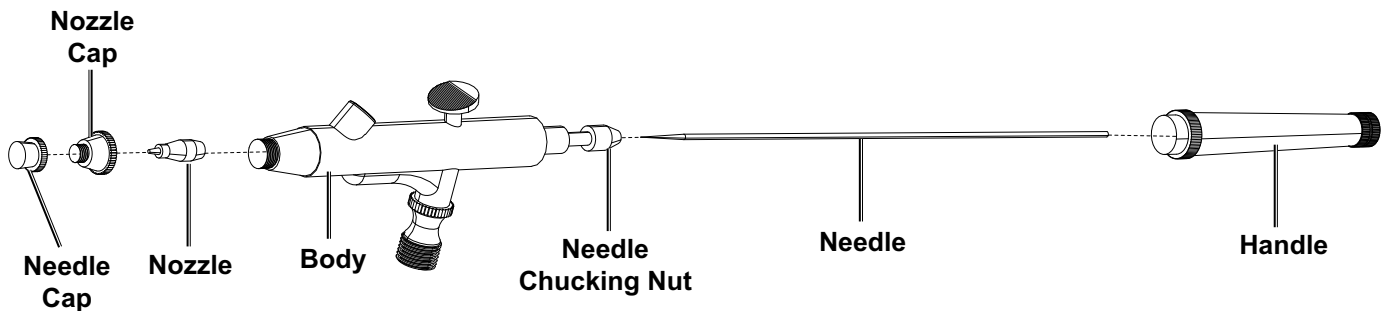

Figure A: Airbrush Parts Breakdown

Waste Disposal

After cleaning, dispose of waste according to paint and solvent manufacturer's directions and local hazardous waste standards.

NOTICE

Clean the Airbrush IMMEDIATELY after use.
Delayed or inadequate cleaning will permanently clog the Airbrush.

Maintenance and Servicing



Procedures not specifically explained in this manual must be performed only by a qualified technician.

WARNING

TO PREVENT SERIOUS INJURY FROM ACCIDENTAL OPERATION:

Turn the Power Switch “OFF” and unplug the Air Compressor from its electrical outlet before performing any inspection, maintenance, or cleaning procedures.

TO PREVENT SERIOUS INJURY FROM AIR COMPRESSOR FAILURE:

Do not use damaged equipment. If abnormal noise or vibration occurs, have the problem corrected before further use.

Cleaning and Maintenance

1. **BEFORE EACH USE**, inspect the general condition. Check for:
 - bent needle,
 - stuck needle,
 - proper trigger movement, and
 - any other condition that may affect its safe operation.
2. **AFTER USE**, clean according to *Clean After Every Use on page 11*, then store indoors out of children’s reach.

NOTICE

Clean the Airbrush IMMEDIATELY after use.
Delayed or inadequate cleaning will permanently clog the Airbrush.

Troubleshooting

Problem	Possible Causes	Likely Solutions
Sputtering spray	<ol style="list-style-type: none">1. Low paint level.2. Improper trigger technique.	<ol style="list-style-type: none">1. Refill Bottle.2. Practice stop-start technique (see page 9).
Does not spray	<ol style="list-style-type: none">1. Too much paint on end of airbrush.2. Needle is not pulling back.3. Nozzle clogged.4. Fluid too thick.	<ol style="list-style-type: none">1. Using solvent, wipe excess paint off the end of the Airbrush.2. Tighten Needle Chucking Nut underneath Handle.3. Clean or replace Nozzle.4. Thin fluid or increase air pressure (do not exceed maximum).
Overspray	<ol style="list-style-type: none">1. Too much air pressure.2. Improper distance from workpiece.3. Improper application speed.	<ol style="list-style-type: none">1. Reduce air pressure.2. Adjust distance.3. Move moderately and parallel.
Poor atomization of paint	<ol style="list-style-type: none">1. Air connection not tight, or leaking.2. Paint not thinned properly.3. Air pressure too low.4. Nozzle is partially plugged.	<ol style="list-style-type: none">1. Check all air connections.2. Add more solvent in very small amounts to the paint you are using and mix thoroughly.3. Increase air pressure (do not exceed maximum).4. Clean or replace Nozzle.



**Follow all safety precautions whenever diagnosing or servicing the compressor.
Disconnect power supply before service.**

NOTICE

Clean the Airbrush IMMEDIATELY after use.
Delayed or inadequate cleaning will permanently clog the Airbrush.

PLEASE READ THE FOLLOWING CAREFULLY

THE MANUFACTURER AND/OR DISTRIBUTOR HAS PROVIDED THE PARTS LIST AND ASSEMBLY DIAGRAM IN THIS MANUAL AS A REFERENCE TOOL ONLY. NEITHER THE MANUFACTURER OR DISTRIBUTOR MAKES ANY REPRESENTATION OR WARRANTY OF ANY KIND TO THE BUYER THAT HE OR SHE IS QUALIFIED TO MAKE ANY REPAIRS TO THE PRODUCT, OR THAT HE OR SHE IS QUALIFIED TO REPLACE ANY PARTS OF THE PRODUCT. IN FACT, THE MANUFACTURER AND/OR DISTRIBUTOR EXPRESSLY STATES THAT ALL REPAIRS AND PARTS REPLACEMENTS SHOULD BE UNDERTAKEN BY CERTIFIED AND LICENSED TECHNICIANS, AND NOT BY THE BUYER. THE BUYER ASSUMES ALL RISK AND LIABILITY ARISING OUT OF HIS OR HER REPAIRS TO THE ORIGINAL PRODUCT OR REPLACEMENT PARTS THERETO, OR ARISING OUT OF HIS OR HER INSTALLATION OF REPLACEMENT PARTS THERETO.

SAFETY

INSTALLATION

OPERATION

MAINTENANCE

Record Product's Serial Number Here: _____

Note: If product has no serial number, record month and year of purchase instead.

Note: Some parts are listed and shown for illustration purposes only, and are not available individually as replacement parts. Specify UPC 193175465405 when ordering parts.

NOTICE

Clean the Airbrush IMMEDIATELY after use.
Delayed or inadequate cleaning will permanently clog the Airbrush.

Parts List and Diagrams

Parts List

Part	Description	Qty
1	Needle Cap	1
2	Nozzle Cap	1
3	O-Ring	1
4	Head Cap	1
5	Small Nozzle	1
6	Big Nozzle	1
7	O-Ring	1
8	Body	1
9	O-Ring	1
10	Cup	1
11	Lid	1
12	Trigger	1
13	O-Ring	1
14	Needle Guide	1
15	Needle Chucking Guide	1

Part	Description	Qty
16	Spring	1
17	Spring Case	1
18	Needle Chucking Nut	1
19	Needle	1
20	Handle	1
21	O-Ring	1
22	Needle Limiting Knob	1
23	O-Ring	1
24	Valve O-Ring	1
25	Valve Body	1
26	Valve Rod O-Ring	1
27	Valve Rod	1
28	Valve Spring	1
29	Valve Screw	1

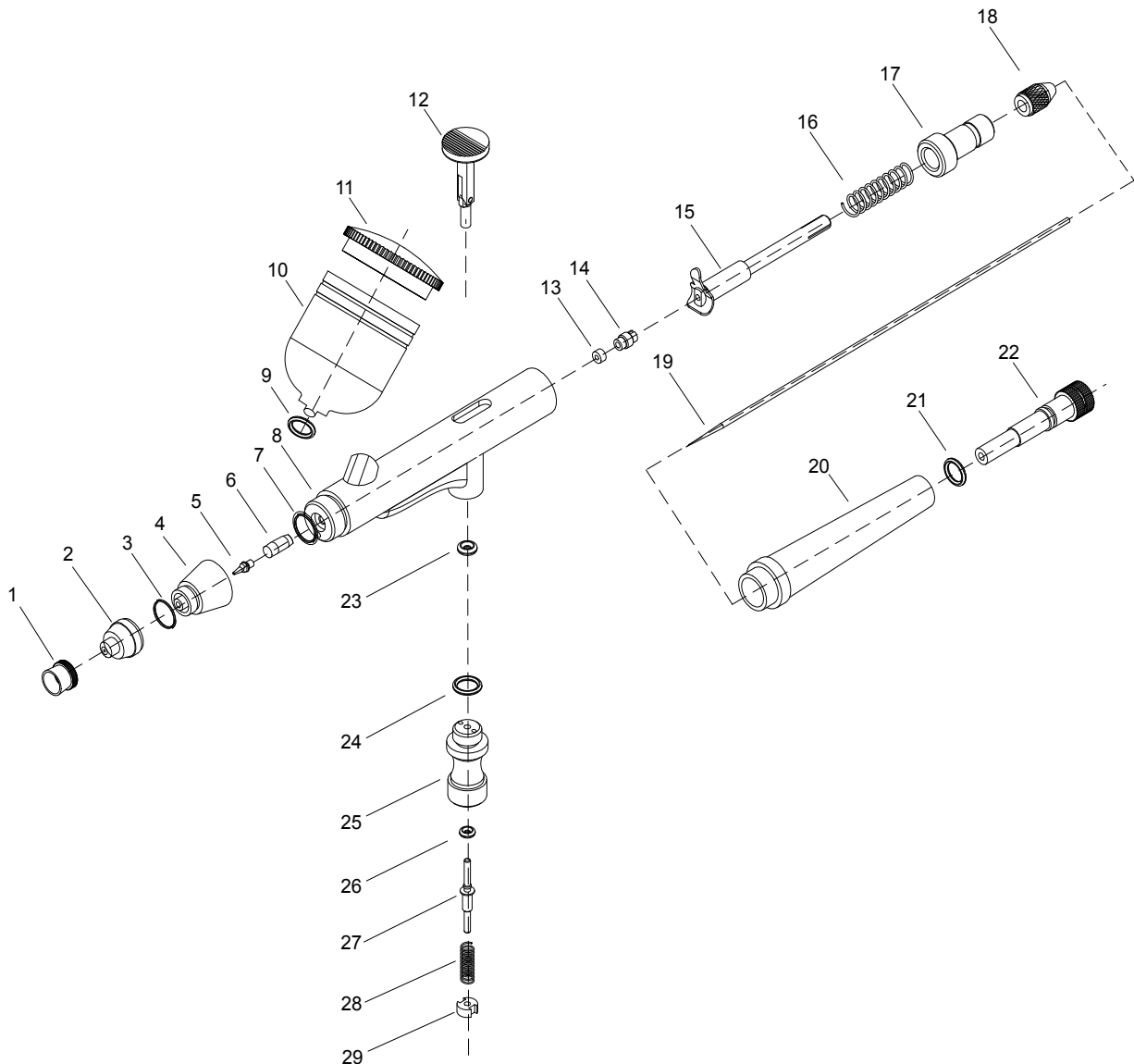

SAFETY

INSTALLATION

OPERATION

MAINTENANCE

Limited 90 Day Warranty

Harbor Freight Tools Co. makes every effort to assure that its products meet high quality and durability standards, and warrants to the original purchaser that this product is free from defects in materials and workmanship for the period of 90 days from the date of purchase. This warranty does not apply to damage due directly or indirectly, to misuse, abuse, negligence or accidents, repairs or alterations outside our facilities, criminal activity, improper installation, normal wear and tear, or to lack of maintenance. We shall in no event be liable for death, injuries to persons or property, or for incidental, contingent, special or consequential damages arising from the use of our product. Some states do not allow the exclusion or limitation of incidental or consequential damages, so the above limitation of exclusion may not apply to you. THIS WARRANTY IS EXPRESSLY IN LIEU OF ALL OTHER WARRANTIES, EXPRESS OR IMPLIED, INCLUDING THE WARRANTIES OF MERCHANTABILITY AND FITNESS.

To take advantage of this warranty, the product or part must be returned to us with transportation charges prepaid. Proof of purchase date and an explanation of the complaint must accompany the merchandise. If our inspection verifies the defect, we will either repair or replace the product at our election or we may elect to refund the purchase price if we cannot readily and quickly provide you with a replacement. We will return repaired products at our expense, but if we determine there is no defect, or that the defect resulted from causes not within the scope of our warranty, then you must bear the cost of returning the product.

This warranty gives you specific legal rights and you may also have other rights which vary from state to state.

AVANTI™

26677 Agoura Road • Calabasas, CA 91302 • 1-888-866-5797