

Installation Guide

Avigilon H5SL Bullet Camera Models:

1.3C-H5SL-BO1-IR

2.0C-H5SL-BO1-IR

3.0C-H5SL-BO1-IR

3.0C-H5SL-BO2-IR

5.0C-H5SL-BO1-IR

5.0C-H5SL-BO2-IR

Legal Notices

© 2023, Avigilon Corporation. All rights reserved. AVIGILON, the AVIGILON logo, AVIGILON CONTROL CENTER, and ACC are trademarks of Avigilon Corporation. Other names or logos mentioned herein may be the trademarks of their respective owners. The absence of the symbols ™ and ® in proximity to each trademark in this document or at all is not a disclaimer of ownership of the related trademark.

Disclaimer

This document has been compiled and published using product descriptions and specifications available at the time of publication. The contents of this document and the specifications of the products discussed herein are subject to change without notice. Avigilon Corporation reserves the right to make any such changes without notice. Neither Avigilon Corporation nor any of its affiliated companies: (1) guarantees the completeness or accuracy of the information contained in this document; or (2) is responsible for your use of, or reliance on, the information. Avigilon Corporation shall not be responsible for any losses or damages (including consequential damages) caused by reliance on the information presented herein.

Avigilon Corporation
avigilon.com

PDF-H5SLBO-A

Revision: 4 - EN

20230609

Important Safety Information

This manual provides installation and operation information and precautions for the use of this device. Incorrect installation could cause an unexpected fault. Before installing this equipment read this manual carefully. Please provide this manual to the owner of the equipment for future reference.



This Warning symbol indicates the presence of dangerous voltage within and outside the product enclosure that may result in a risk of electric shock, serious injury or death to persons if proper precautions are not followed.



This Caution symbol alerts the user to the presence of hazards that may cause minor or moderate injury to persons, damage to property or damage to the product itself if proper precautions are not followed.



WARNING — Failure to observe the following instructions may result in severe injury or death.

- Installation must be performed by qualified personnel only, and must conform to all local codes.
- For EN 50121-4 compliance, this product is intended to be supplied by a EN 50121-4 power source.
- This product is intended to be supplied by Power over Ethernet (PoE) that is a “Limited Power Source” or “LPS”, rated 48 VDC, 9W min.
- Any external power supply connected to this product may only be connected to another Avigilon product of the same model series. External power connections must be properly insulated.
- Do not connect directly to mains power for any reason.



CAUTION — Failure to observe the following instructions may result in injury to persons or damage to the device.

- Do not install near any heat sources such as radiators, heat registers, stoves, or other sources of heat.
- Do not subject the device cables to excessive stress, heavy loads or pinching.
- Do not open or disassemble the device. There are no user serviceable parts.
- Refer all device servicing to qualified personnel. Servicing may be required when the device has been damaged (such as from a liquid spill or fallen objects), has been exposed to rain or moisture, does not operate normally, or has been dropped.
- Do not use strong or abrasive detergents when cleaning the device body.
- Use only accessories recommended by Avigilon.

Regulatory Notices

This device complies with part 15 of the FCC Rules. Operation is subject to the following two conditions: (1) this device may not cause harmful interference, and (2) this device must accept any interference received, including interference that may cause undesired operation.

This Class B digital apparatus complies with Canadian ICES-003.

This device complies with EN 60529 IP66 and IP67 rating.

The Surface Mount and Pendant Mount models comply with EN 60529 IP66 and IP67 rating.

This equipment has been tested and found to comply with the limits for a Class B digital device, pursuant to Part 15 of the FCC rules. These limits are designed to provide reasonable protection against harmful interference in a residential installation. This equipment generates, uses and can radiate radio frequency energy and, if not installed and used in accordance with the instructions, may cause harmful interference to radio communications. However, there is no guarantee that interference will not occur in a particular installation. If this equipment does cause harmful interference to radio or television reception, which can be determined by turning the equipment off and on, the user is encouraged to try to correct the interference by one or more of the following measures:

- Reorient or relocate the receiving antenna.
- Increase the separation between the equipment and the receiver.
- Connect the equipment into an outlet on a circuit different from that to which the receiver is connected.
- Consult the dealer or an experienced radio/TV technician for help.

Changes or modifications made to this equipment not expressly approved by Avigilon Corporation or parties authorized by Avigilon Corporation could void the user's authority to operate this equipment.

To meet the requirements of the EN 50121-4 Railway Applications Standard, use an external power supply or POE injector that is also compliant with EN 50121-4. Please contact Avigilon for assistance regarding supporting equipment.

To meet the requirements of the EN 50130-4 Alarm Systems Applications standard, use an external uninterruptible power (UPS) supply. The UPS must have a backup run time of greater than 5 seconds (>5S) for the power level as specified on the product datasheet.

For Korea

이 기기는 가정용(B급) 전자파적합기기로서 주로 가정에서 사용하는 것을 목적으로 하며, 모든 지역에서 사용할 수 있습니다.

Disposal and Recycling Information

When this product has reached the end of its useful life, please dispose of it according to your local

environmental laws and guidelines.

This equipment contains a coin cell battery.

Risk of fire, explosion, and burns. Do not disassemble, crush, heat above 100 °C (212 °F), or incinerate.

European Union:



This symbol means that according to local laws and regulations your product should be disposed of separately from household waste. When this product reaches its end of life, take it to a collection point designated by local authorities. Some collection points accept products for free. The separate collection and recycling of your product at the time of disposal will help conserve natural resources and ensure that it is recycled in a manner that protects human health and the environment.

Table of Contents

Overview	1
Mounting Bracket View	1
Rear View	2
Front View	3
Configuration Panel View	4
Side View	5
Installation	6
Camera Package Contents	6
Installation Steps	6
Mounting the Bullet Camera	6
Removing the Configuration Panel Cover	10
Initializing a Camera Username and Password	10
(Optional) Using the USB Wi-Fi Adapter	11
Assigning an IP Address	11
Accessing the Live Video Stream	12
Aiming the Camera	12
Zooming and Focusing the Camera	14
(Optional) Configuring microSD Card Storage	14
Configuring the Camera	14
For More Information	15
Connecting to External Audio and I/O Devices	16
Connection Status LED Indicator	17
Troubleshooting Network Connections and LED Behavior	17
Resetting to Factory Default Settings	19
Setting the IP Address Using the ARP/Ping Method	20
Limited Warranty and Technical Support	21

Overview

Mounting Bracket View

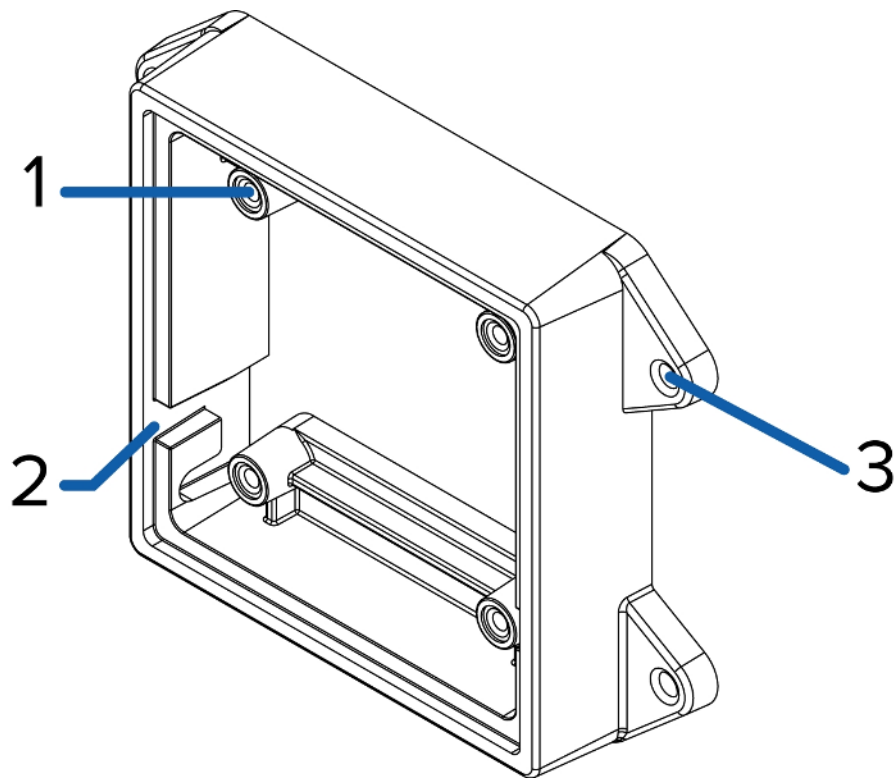

1. **Camera mounts**
Points for installing the camera to the mounting bracket.
2. **Mounting hook slots**
Points to hold the camera to the mounting bracket while connecting the required cables.
3. **Mounting holes**
Holes for securing the mounting bracket to the mounting surface.

Rear View

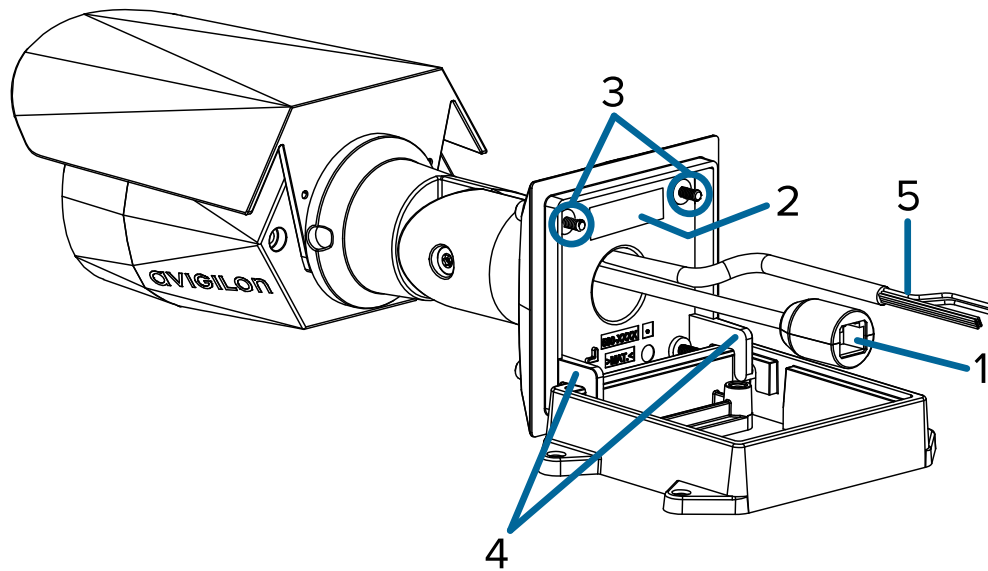

1. **Ethernet port**

Accepts power and Ethernet connection to the network.

The camera can only be powered by Power over Ethernet (PoE). Server communication and image data transmission also occur over this connection.

2. **Serial number tag**

Device information, product serial number and part number label.

3. **Camera mounting screws**

Screws for mounting the camera to the mounting bracket.

4. **Mounting hooks**

Hooks to attach the camera to the mounting bracket while connecting the required cables.

5. **External I/O and audio cables**

Cables for connecting to external audio and I/O devices. For more information, see *Connecting to External Audio and I/O Devices* on page 16.

Front View

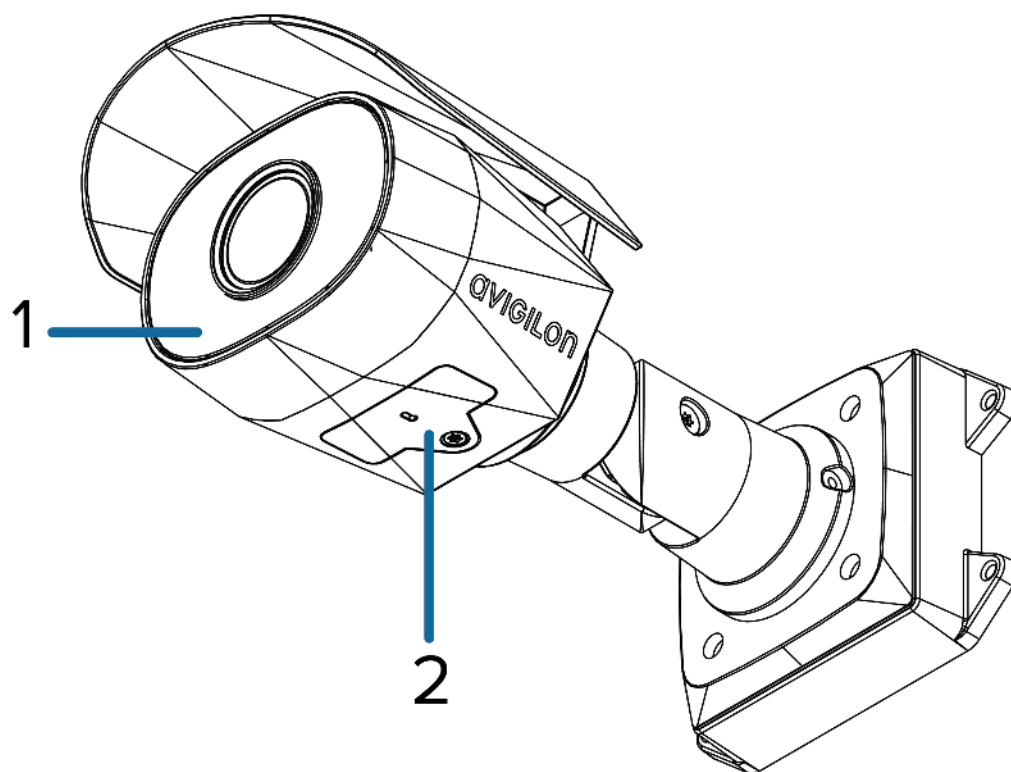

1. **IR illuminator**
Provides scene illumination in the IR spectrum.
2. **Configuration panel cover**
Covers the configuration panel.

Configuration Panel View

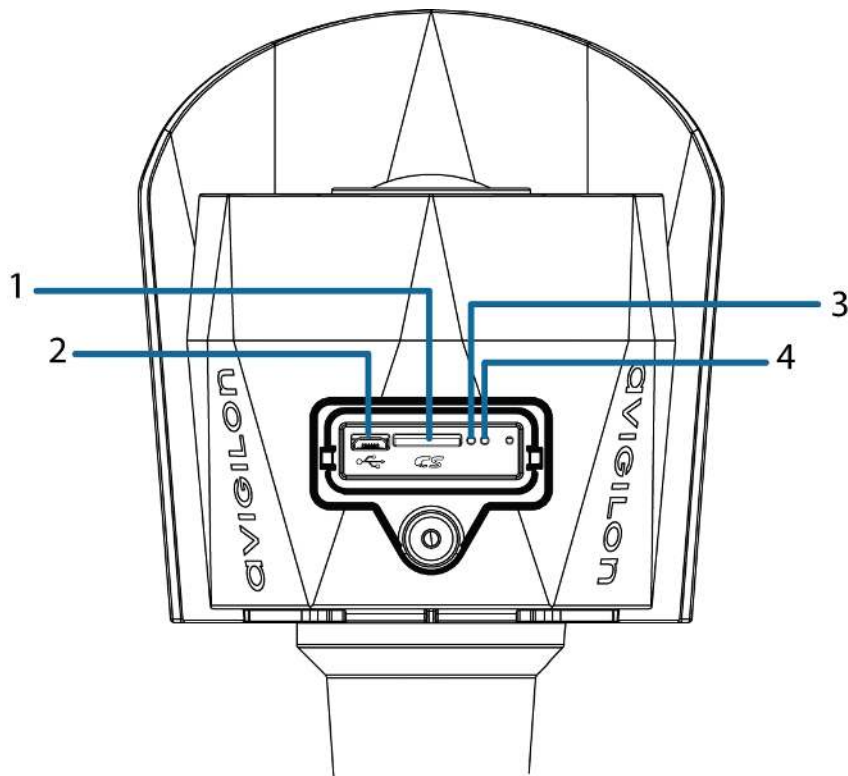

1. **microSD card slot**

Accepts a microSD card for onboard storage. For more information, see *(Optional) Configuring microSD Card Storage* on page 14.

2. **Micro USB port**

Accepts a micro USB to USB adapter. Only required when using the Avigilon USB Wi-Fi Adapter.

3. **Link LED indicator**

Amber LED indicates if there is an active connection in the Ethernet port.

4. **Connection status LED indicator**

Green LED provides information about device operation. For more information, see *Connection Status LED Indicator* on page 17.

Side View

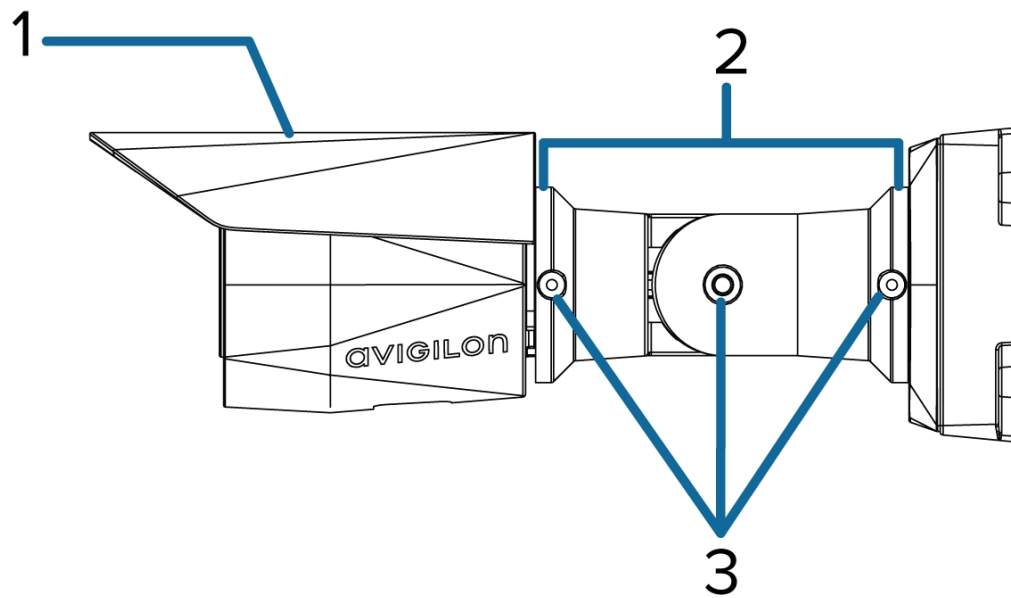

1. **Sun shroud**
An adjustable cover to help protect the lens against glare from the sun.
2. **Mount arm**
Adjustable mount arm for positioning the camera.
3. **Adjustment screws**
Provides a locking mechanism for the mount arm.

Installation

Camera Package Contents

- Avigilon H5SL Bullet Camera
- Mounting template sticker
- 4 screws and anchors for solid walls

Installation Steps

Complete the following sections to install the device.

Mounting the Bullet Camera

If the cables for the camera will not be provided from inside the mounting surface, install the junction box first (H4-BO-JBOX). After you install the junction box, you can skip directly to step 3 of this procedure.

1. Use the mounting template to drill four mounting holes into the mounting surface.

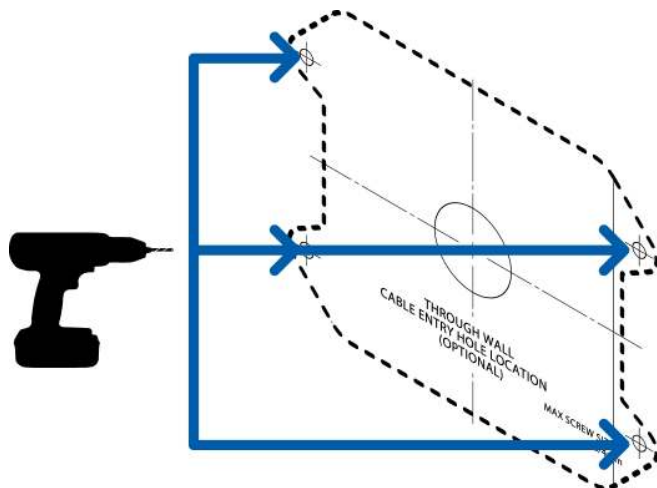

2. Drill the cable entry hole into the mounting surface then pull the required Ethernet cable through the cable entry hole.

3. Fasten the mounting bracket to the mounting surface or junction box.

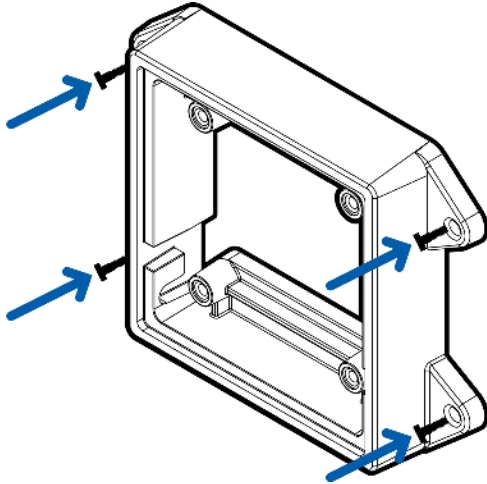

Note: It is recommended that silicone sealant be applied around the edge of the mounting bracket or junction box to prevent moisture from entering the mounting surface.

4. Insert the mounting hooks on the rear of the camera into the mounting hook slots on the mounting bracket, then let the camera hang.

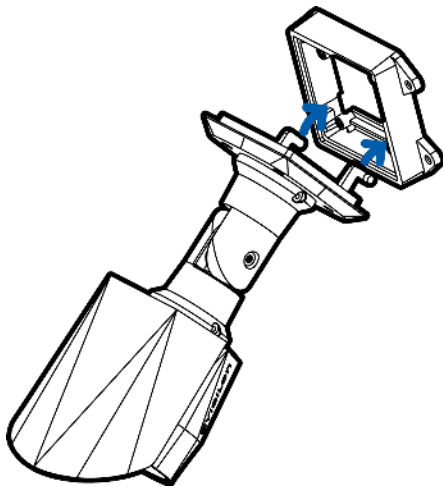

Note: Before connecting any cables, ensure that the cable connections are properly protected from moisture and corrosion. Make sure the protective cable boot is installed over the Ethernet port to protect the connection from dust and moisture.

5. If there are external input or output devices that need to be connected to the camera (for example: door contacts, relays, etc.), connect the devices to the camera's digital I/O connector cables. For more information see *Connecting to External Audio and I/O Devices* on page 16.

6. If an external microphone and/or speakers need to be connected to the camera, connect the devices to the camera's audio I/O cables. For more information, see *Connecting to External Audio and I/O Devices* on page 16.
7. Install the protective cable boot. You may choose to skip this step if you are using the optional junction box.

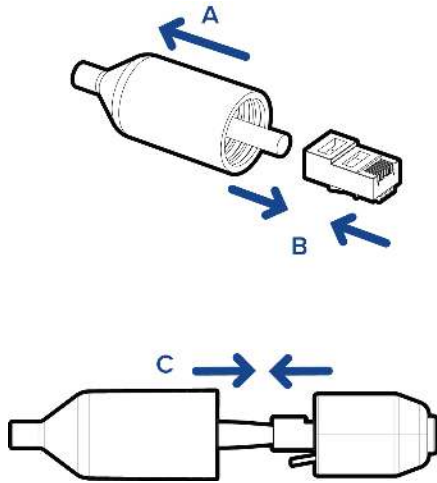

- a. Remove the protective cable boot that is preinstalled over the Ethernet port, then thread one end of the Ethernet cable through it.
Ensure the orientation of the cable and boot matches the one shown in the image.
 - b. Crimp the Ethernet cable.
 - c. After you connect the cable to the camera, slide the boot over the Ethernet port.
8. Connect the network cable to the camera's Ethernet port.

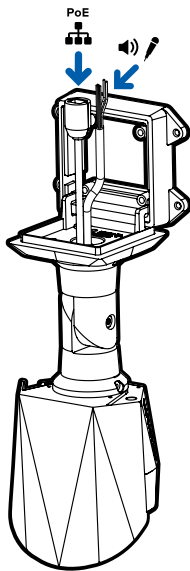

9. Tuck the extra lengths of cables into the cable entry hole.

10. Raise the camera until it covers the mounting bracket.

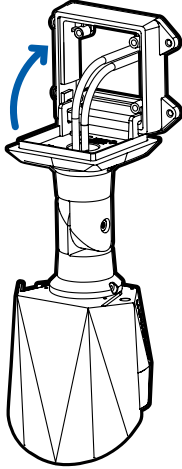

11. Use the camera mounting screws to fasten the camera to the bracket.

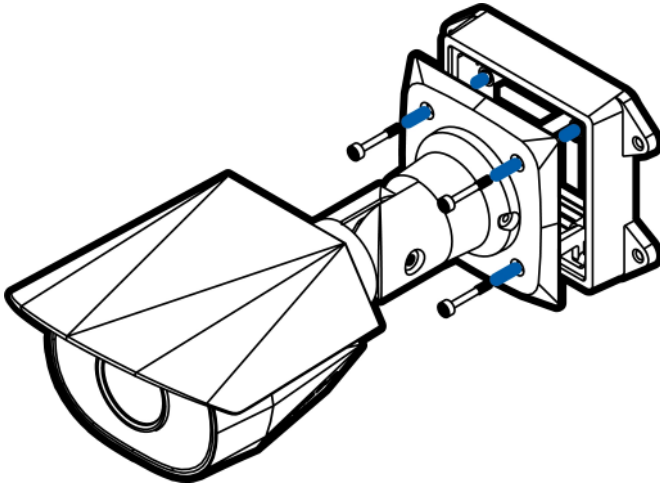

Removing the Configuration Panel Cover

1. Use a T20 Pin-In star-shaped driver to unscrew the configuration panel cover.

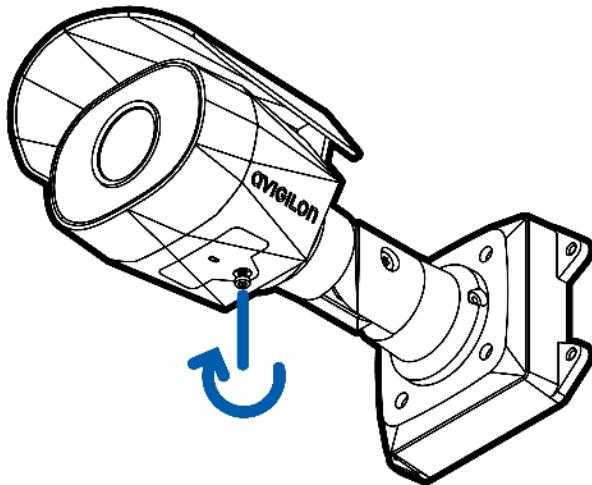

2. Remove the cover from the configuration panel.

Initializing a Camera Username and Password

Cameras manufactured after January 1, 2020, do not have a default username or password and will be in a factory default state.

Important: You must create a user with *administrator* privileges before the camera is operational.

The first user can be created using any of the following methods:

- Camera's Web Interface: enter the camera's IP address in a web browser to access the web interface. If the camera is in the factory default state you will be redirected to the Add a new user page to create the first user. For more information, see the *Avigilon High Definition H4 and H5 IP Camera Web Interface User Guide*.
- Camera Configuration Tool: cameras discovered in the factory default state will be identified by . Select the **Admin Users** tab to create the first user. For more information, see the *Avigilon Camera Configuration Tool User Guide*.
- USB Wi-Fi Adapter: when connecting a camera in the factory default state, you will be redirected to the Create Administrator User page to create the first user. For more information, see *Motorola Solutions USB Wi-Fi Adapter System User Guide*.
- Avigilon Control Center software version 7.4 or later, or version 6.14.12 or later: when connecting a camera in the factory default state, the client software will ask you to create a new user. For more information, see the *Avigilon Control Center Client User Guide*.
- Avigilon Cloud Services (ACS) v3.0 or later: when adding a camera you will be asked to create a new user for cameras in the factory default state. For more information, see the *Avigilon Cloud Services User Guide*.

Tip: If you are connecting your Avigilon camera to a 3rd party VMS, you will need to set up the first user through the camera's Web Interface, USB Wifi Adapter, or Camera Configuration Tool before you connect to the 3rd party VMS.

(Optional) Using the USB Wi-Fi Adapter

If you have a USB Wi-Fi Adapter (H4-AC-WIFI), attach it to the camera's micro USB port to access the camera's mobile web interface.

After you connect to the Wi-Fi signal broadcast by the adapter, you can access the mobile web interface from any mobile device using the following address:

`http://camera.lan`

For more information about configuring the camera from the mobile web interface see *Avigilon USB Wi-Fi Adapter System User Guide*.

Note: The camera will reserve the 10.11.22.32/28 subnet for internal use while the USB Wi-Fi Adapter is plugged in.

Assigning an IP Address

The device automatically obtains an IP address when it is connected to a network.

Note: If the device cannot obtain an IP address from a DHCP server, it will use Zero Configuration Networking (Zeroconf) to choose an IP address. When set using Zeroconf, the IP address is in the 169.254.0.0/16 subnet.

The IP address settings can be changed using one of the following methods:

- The mobile web interface using the USB Wifi Adapter. For more information, see *(Optional) Using the USB Wi-Fi Adapter* above.
- Device's web browser interface: `http://<camera IP address>/`.
- Network Video Management software application (for example, the Avigilon Control Center™ software).
- ARP/Ping method. For more information, see *Setting the IP Address Using the ARP/Ping Method* on page 20.

Note:

Depending on the manufacture date of your camera, you will have one of the two options below to log in for the first time:

- Cameras manufactured after January 1, 2020: these cameras do not have a default username or password and will be in a factory default state. **You must create a user with *administrator* privileges before the camera is operational.** For more information, see *Initializing a Camera Username and Password* on page 10.
- Cameras manufactured before January 1, 2020: login to the camera using the default username of `administrator` with no password. It is recommended that you change the password after your first login.

Accessing the Live Video Stream

Live video stream can be viewed using one of the following methods:

- The mobile web interface using the USB Wifi Adapter. For more information, see *(Optional) Using the USB Wi-Fi Adapter* on the previous page.
- Web browser interface: `http://< camera IP address>/`.
- Network Video Management software application (for example, the Avigilon Control Center software).

Note:

Depending on the manufacture date of your camera, you will have one of the two options below to log in for the first time:

- Cameras manufactured after January 1, 2020: these cameras do not have a default username or password and will be in a factory default state. **You must create a user with *administrator* privileges before the camera is operational.** For more information, see *Initializing a Camera Username and Password* on page 10.
- Cameras manufactured before January 1, 2020: login to the camera using the default username of `administrator` with no password. It is recommended that you change the password after your first login.

Aiming the Camera

Reference the camera's live stream as you aim the camera.

1. Loosen the adjustment screw closest to the mounting bracket to rotate the camera arm.

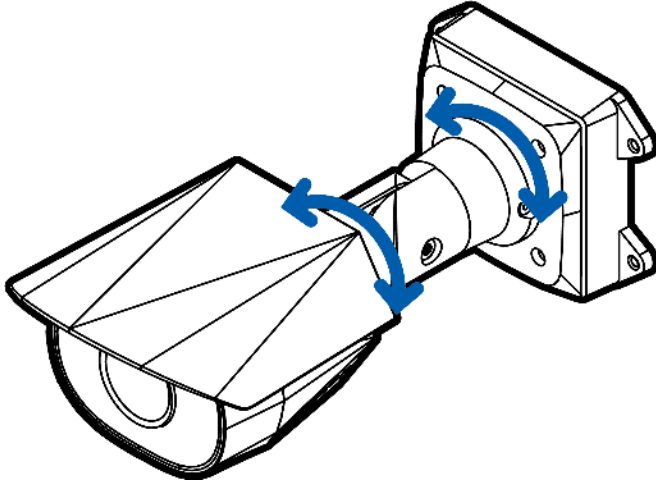

2. Loosen the center adjustment screw to tilt the camera.

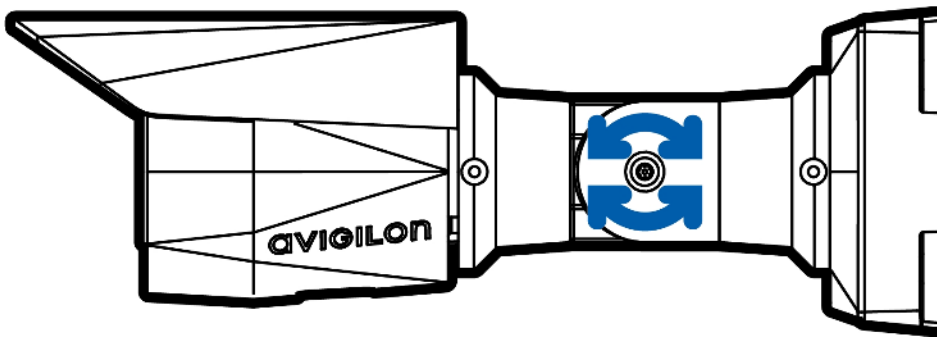

3. Loosen the adjustment screw on the camera to turn the camera body.

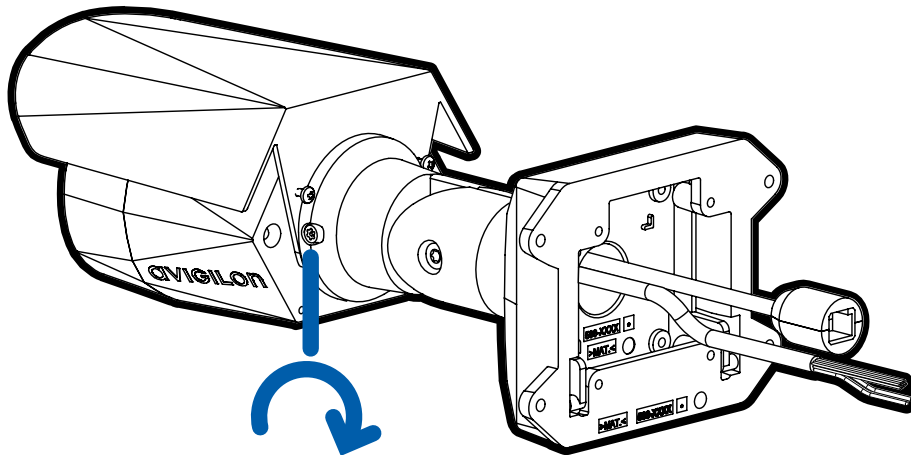

4. If the camera is turned sideways to look vertically at a scene, you can remove the sun shroud then re-install it to cover the camera's new angle of view.

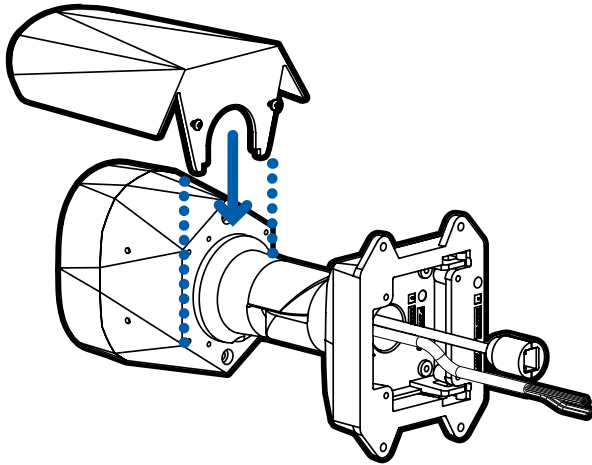

Zooming and Focusing the Camera

- In the camera web browser interface or the Avigilon Control Center software, use the camera's Image and Display settings to zoom and focus the camera.
 - a. Use the zoom buttons to zoom the camera in or out.
 - b. Click **Auto Focus** to focus the lens.
 - c. Use the focus near and far buttons to manually adjust the focus.

(Optional) Configuring microSD Card Storage

To use the camera's SD card storage feature, you must insert a microSD card into the card slot.

It is recommended that the microSD card have a write speed of class 10 or better. If the microSD card does not meet the recommended write speed, the recording performance may suffer and result in the loss of frames or footage.

1. Insert a microSD card into the camera.



CAUTION — Do not force the microSD card into the camera or you may damage the card and the camera.

2. Access the camera's web interface to enable the onboard storage feature. For more information, see the *Avigilon High Definition H4 and H5 IP Camera Web Interface User Guide*.

Configuring the Camera

Once installed, use one of the following methods to configure the camera:

- If you have the USB Wifi Adapter, you can access the mobile web interface to configure the camera. For more information, see *Avigilon USB Wi-Fi Adapter System User Guide*.
- If you have installed multiple cameras, you can use the Camera Configuration Tool to configure common settings. For more information, see the *Camera Configuration Tool User Guide*.

- If the camera is connected to the Avigilon Control Center system, you can use the client software to configure the camera. For more information, see the *Avigilon Control Center Client User Guide*.
- If the camera is connected to a third-party network management system, you can configure the camera's specialty features in the camera's web browser interface. For more information, see the *Avigilon High Definition H4 and H5 IP Camera Web Interface User Guide*.

For More Information

Additional information about setting up and using the device is available in the following guides:

- *Avigilon Control Center Client User Guide*
- *Web Interface User Guide — Avigilon High Definition H4 and H5 IP Cameras*
- *Web Interface User Guide — Avigilon High Definition H4 and H5 IP Cameras*
- *Avigilon USB Wi-Fi Adapter System User Guide*
- *Avigilon USB Wi-Fi Adapter System User Guide*
- *Avigilon Camera Configuration Tool User Guide*
- *Designing a Site with Avigilon Video Analytics*

These guides are available on help.avigilon.com and on the Avigilon website: avigilon.com/support.

Connecting to External Audio and I/O Devices

Important: This product is intended to be supplied by Power over Ethernet (PoE). Do NOT connect auxiliary power to the audio or I/O wires or the camera will be damaged.

WARNING — This product is intended to be supplied by Power over Ethernet (PoE) that is a “Limited Power Source” or “LPS”, rated 48 VDC, 9 W min.

External audio and I/O devices are connected to the camera through the audio and I/O wires. The pinout for the wires is shown in the following diagram:

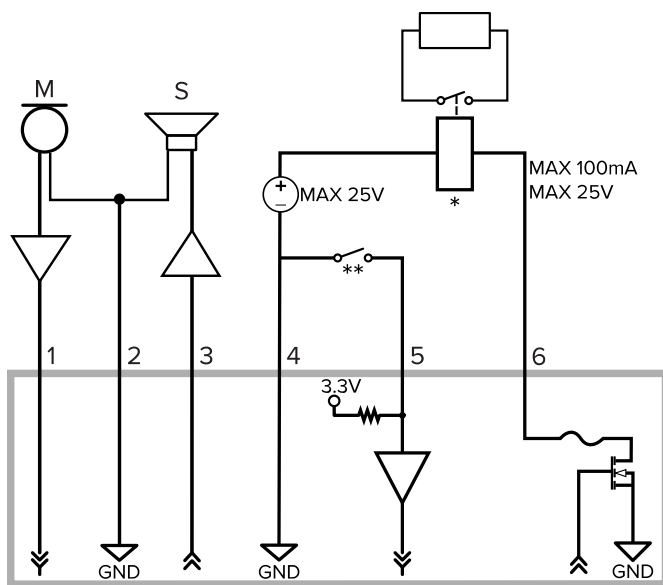

1. Grey — Audio Input (line level)
An external power amplifier should be used when connecting speakers and microphones, as shown in the diagram.
2. Red — Audio Ground
3. Pink — Audio Output (line level)
4. Green — Ground
5. Yellow — Digital Input
6. Brown — Digital Output
 - * — Relay
 - ** — Switch
 - M — Microphone
 - S — Speaker

Connection Status LED Indicator

Once connected to the network, the green Connection Status LED indicator will display the progress in connecting to the Network Video Management software.

The following table describes what the LED indicator shows:

Connection State	Connection Status LED Indicator	Description
Obtaining IP Address	One short flash every second	Attempting to obtain an IP address.
Discoverable	Two short flashes every second	Obtained an IP address but not connected to the Network Video Management software.
Upgrading Firmware	Two short flashes and one long flash every second	Updating the firmware.
Connected	On	Connected to the Network Video Management software or an ACC™ Server. The default connected setting can be changed to Off using the camera's web user interface. For more information see the <i>Avigilon High Definition H4 and H5 IP Camera Web Interface User Guide</i> .

Troubleshooting Network Connections and LED Behavior

Note: For any of the below LED behaviors, ensure that the camera is getting power and is using a good network cable before trying another solution.

LED Behavior	Suggested Solution
Green LED is off and amber is on	Perform a factory reset of the camera using the physical firmware revert button. Resetting through the camera's web interface will not produce the desired result.
Both LEDs are off and the camera is not connected or streaming video	Check the General setup page in the camera's web interface to ensure the LEDs are not disabled. If the LEDs are not disabled, perform a factory reset of the camera using the physical firmware revert button. Resetting through the camera's web interface will not produce the desired result.

LED Behavior	Suggested Solution
Both LEDs are blinking several times at the same time, then pause and repeat the blinking	Perform a factory reset of the camera using the physical firmware revert button. Resetting through the camera's web interface will not produce the desired result.
A different LED blinking pattern than those described above	Perform a factory reset of the camera using the physical firmware revert button. Resetting through the camera's web interface will not produce the desired result.

Resetting to Factory Default Settings

If the device no longer functions as expected, you can choose to reset the device to its factory default settings.

Use the firmware revert button to reset the device. The firmware revert button is shown in the following diagram:

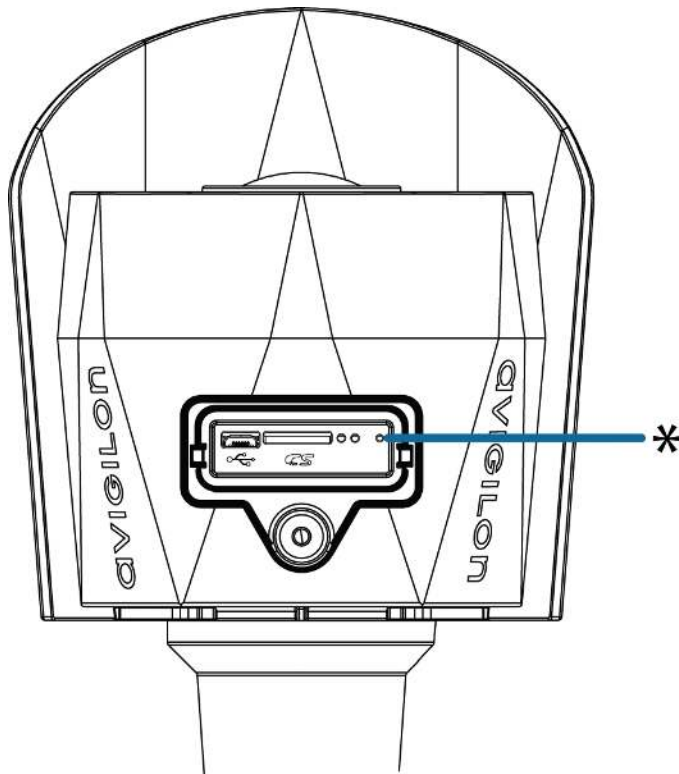

Figure 1: The firmware revert button in the Configuration Panel.

1. Ensure the device is powered on.
2. Using a straightened paperclip or similar tool, gently press and hold the firmware revert button.
3. Release the button after three seconds.



CAUTION — Do not apply excessive force. Inserting the tool too far may damage the camera.

Setting the IP Address Using the ARP/Ping Method

Complete the following steps to configure the camera to use a specific IP address:

Note: The ARP/Ping Method will not work if the **Disable setting static IP address through ARP/Ping method** checkbox is selected in the camera's web browser interface. For more information, see the *Avigilon High Definition H4 and H5 IP Camera Web Interface User Guide*.

1. Locate and make note of the MAC Address (MAC) listed on the Serial Number Tag for reference.
2. Open a Command Prompt window and enter the following commands:
 - a. `arp -s <New Camera IP Address> <Camera MAC Address>`
For example: `arp -s 192.168.1.10 00-18-85-12-45-78`
 - b. `ping -l 123 -t <New Camera IP Address>`
For example: `ping -l 123 -t 192.168.1.10`
3. Reboot the camera.
4. Close the Command Prompt window when you see the following message:
Reply from <New Camera IP Address>: ...

Limited Warranty and Technical Support

Avigilon warranty terms for this product are provided at [avigilon.com/warranty](https://www.avigilon.com/warranty).

Warranty service and technical support can be obtained by contacting Avigilon Technical Support: [avigilon.com/contact](https://www.avigilon.com/contact).