

## 1 Description

The Electromagnetic Lock (Maglock) series is a surface-mounted, magnetic-lock assembly. They are available in single- and double-lock varieties, various sizes (i.e. force), and also available with or without built-in Door Status Switch ("DS" versions). All models are designed for standard installation on most types of doors (1 3/8 to 2" thickness).



	door configuration		door status sensor	
	single	double	with	without
10MAGLOCK3UL	✓			✓
10MAGLOCK3ULDS	✓		✓	
10MAGLOCK6UL		✓		✓
10MAGLOCK6ULDS		✓	✓	

## 2 Specifications

**ATTENTION: This product must be powered from a UL-listed, regulated, power-limited, power supply!**

DESCRIPTION	10MAGLOCK3UL 10MAGLOCK3ULDS	10MAGLOCK6UL 10MAGLOCK6ULDS
Lock:	single	double
Input Voltage:	12 or 24 VDC	12 or 24 VDC
Bond Status Relay (when powered):	1.0 A @ 24 VDC resistive	1.0 A @ 24 VDC resistive
Relay Power Factor:	1	1
Door Status Switch:	dry contacts: 3W (switching contact 0.25 amps max, switching voltage 30VDC max; resistive load)	dry contacts: 3W (switching contact 0.25 amps max, switching voltage 30VDC max; resistive load)
Reed Switch Power Factor:	1	1
Power Consumption:	500 mA @ 12 VDC / 250 mA @ 24 VDC	500 mA @ 12 VDC / 250 mA @ 24 VDC each
Dimensions:	9.84 × 1.66 × 1.04 in 250 × 42.2 × 26.5 mm	19.685 × 1.66 × 1.04 in 500 × 42.2 × 26.5 mm
Certification:	UL294	UL294
Operating Temperature:	32 – 120 °F (0 – 49 °C)	32 – 120 °F (0 – 49 °C)
Operating Humidity:	0 – 85%	0 – 85%

**NOTE:** The specifications listed above are for an indoor, dry, installation location.

### UL 294 Performance Ratings:

(required per Chapter 10 of 2015 IBC)

Destructive:	Level I	Line Security:	Level I
Endurance:	Level IV	Standby Power:	Level I
Static Strength:	500 lb	Dynamic Strength:	33 ft/lb

### 3 Precautions



- ☑ Shut off all power going to header before attempting any wiring procedures.
- ☑ Maintain a clean and safe environment when working in public areas.
- ☑ Constantly be aware of pedestrian traffic around the door area.
- ☑ Always stop pedestrian traffic through the doorway when performing tests that may result in unexpected reactions by the door.
- ☑ Always check placement of all wiring before powering up to ensure that moving door parts will not catch any wires and cause damage to equipment or cable insulation.
- ☑ Ensure compliance with all applicable safety standards (i.e. ANSI A156.10) upon completion of installation.

### 4 Installation Notes

- ☑ Handle the equipment with care. Damaging the mating surfaces of the magnet and armature plate may reduce locking efficiency.
- ☑ The MAGLOCK mounts rigidly to the door frame. The armature plate mounts to the door with the hardware provided. This allows the armature plate to pivot about its center to compensate for door wear and misalignment.
- ☑ You must only use the template with the door in its normally closed position.
- ☑ **Add threadlocker to all screws before installing, and firmly tighten screws.**
- ☑ Install only for indoor, dry applications.
- ☑ Installation and wiring must be performed in compliance with ANSI / NFPA 70 / NFPA 101 / CSA C22.1, Canadian Electrical Code, Part I, safety standard for electrical installations, section 32; and CAN/ULC-S524 installation of fire alarm system requirements.
- ☑ The MAGLOCK shall be installed within the same room as other equipment and circuitry connecting to the MAGLOCK.
- ☑ Wiring must be cased to avoid outer cable damage, affect the insulation distance.
- ☑ An electric locking mechanism shall not impair the operation of panic hardware mounted on the door.
- ☑ An electric locking mechanism shall not impair the intended operation of an emergency exit.

### 5 Installation – Mechanical

#### TYPICAL INSTALLATION

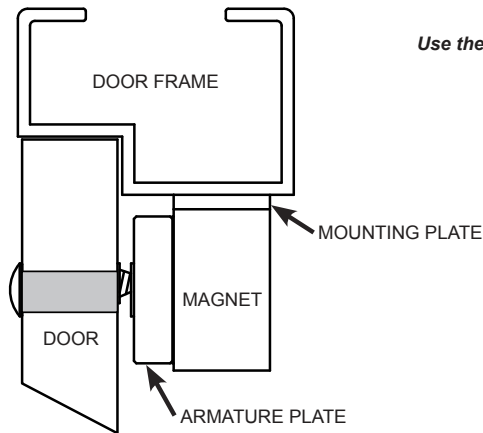

Use the applicable mounting template.

**DO NOT over-tighten the armature plate.**

The rubber washer is designed to allow the armature plate to automatically adjust position for best mating position between the magnet and armature plate.

### 6 Armature Plate Installation

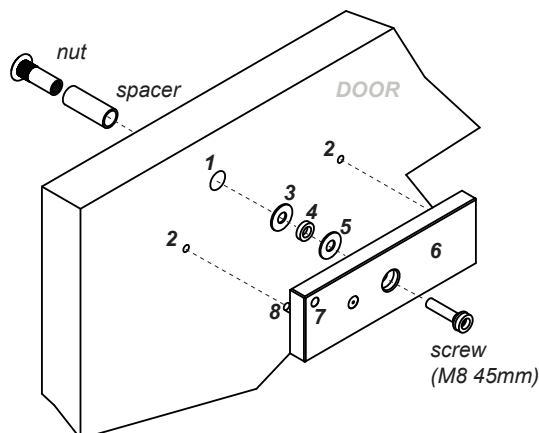

1. hole for nut
  2. hole for guide pin
  3. steel washer
  4. rubber washer
  5. steel washer
  6. armature plate
  7. permanent magnet (door status switch)
  8. guide pin
- Ensure proper orientation of armature plate (i.e. magnet positioned in upper left or right corner - see diagram)

**Apply threadlocker directly to all screws before installing, and then firmly tighten the screws.**

#### SIDE VIEW

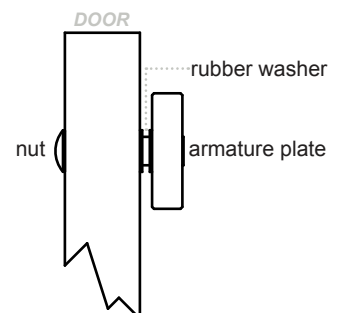

# 7 Installation – Electrical

## CIRCUIT BOARD

**NOTE: Terminals ratings: 16–22AWG (copper wire)**

### With lock sensor, LED, and timer

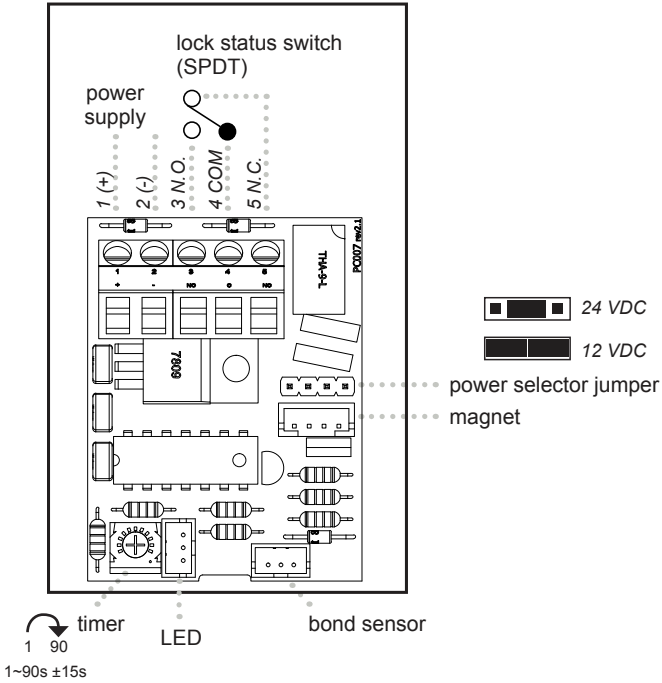

### With lock sensor and LED

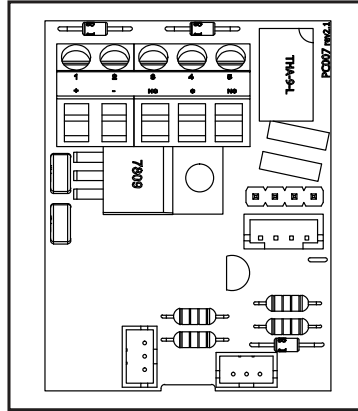

### Unmonitored

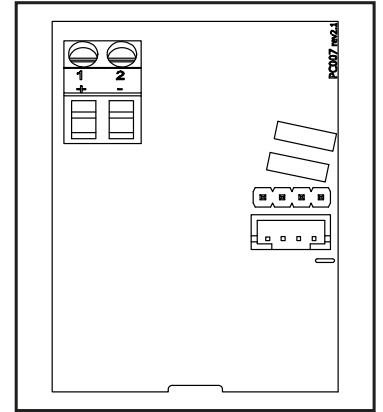

### Reed switch (door sensor type) - optional

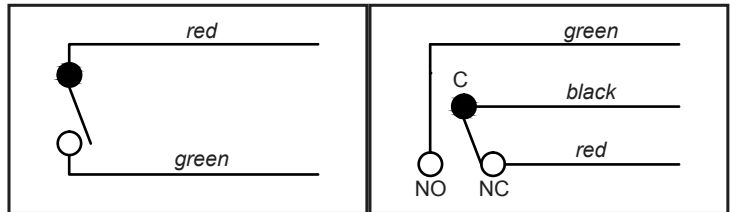

## POWER

**The product must be powered from a UL-listed, regulated, power-limited, power supply.**

### 12 VDC INPUT

- Required power: 0.5 AMP / 12 VDC
- Connect positive (+) lead from a 12 VDC power source to Terminal 1.
- Connect negative (-) lead from a 12 VDC power source to Terminal 2.
- Check jumper for 12 VDC operation.

### 24 VDC INPUT

- Required power: 0.25 AMP / 24 VDC
- Connect positive (+) lead from a 24 VDC power source to Terminal 1.
- Connect negative (-) lead from a 24 VDC power source to Terminal 2.
- Check jumper for 24 VDC operation.

**If power switch is not wired between DC source voltage(+) and magnet, it will take a longer time to de-energize the magnet simulating residual magnetism.**

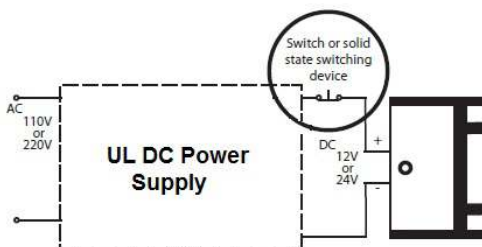

### *SWITCHES (optional)*

#### **LOCK STATUS RELAY CONTACT (SPDT) AND DOOR STATUS SWITCH**

- Relay dry contacts are rated 1A at 24 VDC for safe operation, DO NOT exceed this rating.
- The reed switch dry contacts are rated at 3W (switching contact 0.25 amps max, switching voltage 30VDC max; resistive load) for safe operation.
- If a NO switch is required, connect the wires from the system to Terminal 3 and Terminal 4.
- If a NC switch is required, connect the wires from the system to Terminal 4 and Terminal 5.

\* Switch changes state when door is open

### **BEA, INC. INSTALLATION/SERVICE COMPLIANCE EXPECTATIONS**

BEA Inc., the sensor manufacturer, cannot be held responsible for incorrect installations or incorrect adjustments of the sensor/device; therefore, BEA Inc. does not guarantee any use of the sensor/device outside its intended purpose.

BEA Inc. strongly recommends that installation and service technicians be AAADM-certified for pedestrian doors, IDA-certified for doors/gates, and factory-trained for the type of door/gate system.

Installers and service personnel are responsible for executing a risk assessment following each installation/service performed, ensuring that the sensor/device system performance is compliant with local, national, and international regulations, codes, and standards.

Once installation or service work is complete, a safety inspection of the system shall be performed and documented per the manufacturer's recommendations or industry guidelines. Examples of compliance may apply to ANSI 156.10, ANSI 156.19, ANSI/DASMA 102, ANSI/DASMA 107, UL294, UL325, and International Building Code.