

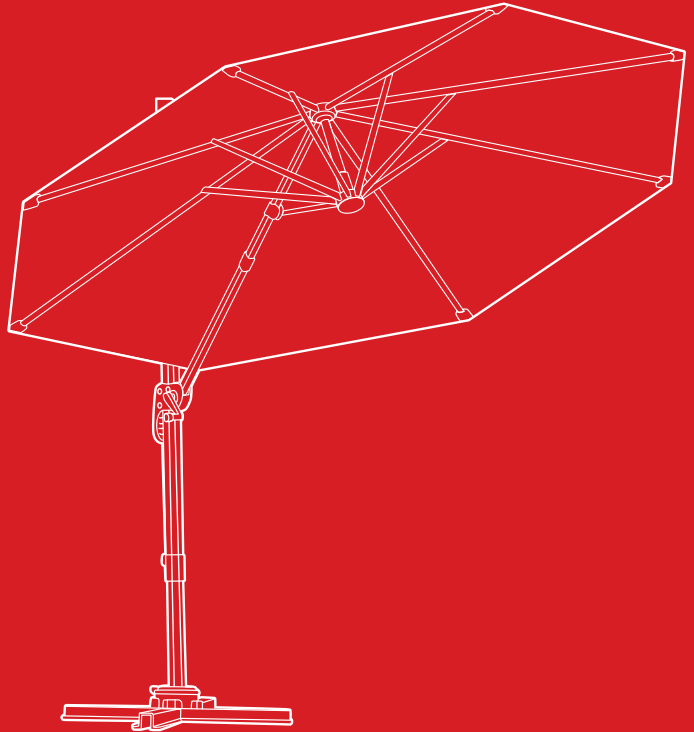

bestchoiceproducts



INSTRUCTION MANUAL

10ft Offset Patio Umbrella with Cover

Ver. 1

SKY5257 + SKY5258 + SKY5259 + SKY5260 + SKY5261
SKY5262 + SKY5263 + SKY5264 + SKY5265



bestchoiceproducts

As shoppers, we're always trying to find the perfect balance between quality & value. At BCP, we believe we've achieved that. Our diverse catalog of everyday essentials is tailored especially to our customers & guaranteed to hit that sweet spot of high quality & low price.

— Always. —

! NOTICE

Please retain these instructions for future reference.

- Firmly secure all bolts, screws and knobs before use.
- Reconfirm that all bolts, screws, and knobs are secure every 90 days.
- Fasten screws loosely during initial assembly. Do not firmly tighten the screws until the item is completely assembled.
- Be aware that some parts are heavy and have sharp edges.
- If any parts are missing, broken, damaged, or worn, stop using this product until repairs are made and/or factory replacement parts are installed.
- Do not use this item in a way inconsistent with the manufacturer's instructions as this could void the product warranty.

TOOLS REQUIRED



WRENCH
(PROVIDED)



2 PERSON
ASSEMBLY



APPROXIMATELY
30 MIN.
ASSEMBLY

HARDWARE

1

M8x14mm
SCREW



8 PCS

2

M8 WASHER



8 PCS

3

KNOB

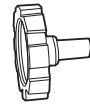

1 PC

PARTS

A UPPER CROSSBAR

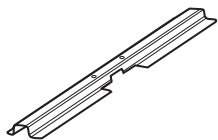

1 PC

B LOWER CROSSBAR

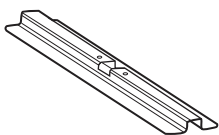

1 PC

C ROTATING BASE



1 PC

D POLE

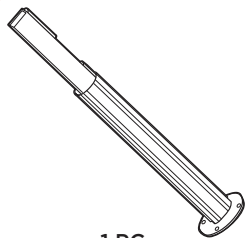

1 PC

E BASE COVER

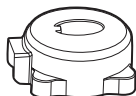

1 PC

F SLEEVE

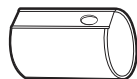

1 PC

G UMBRELLA

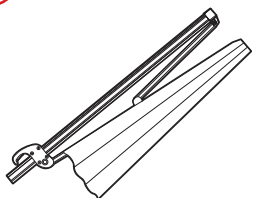

1 PC

H CRANK



1 PC

I COVER POLE

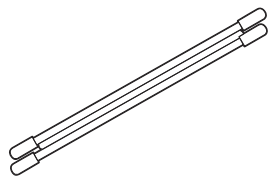

1 PC

J COVER

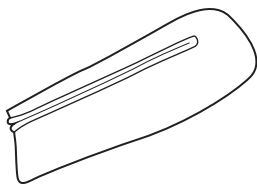

1 PC

BEFORE FIRST USE

1. Hold the umbrella upside down and shake gently to separate the umbrella ribs. If necessary, carefully pull the ribs apart to free them.
2. Slowly turn the crank to open the umbrella. Make sure that the ribs are not stuck together.

PRODUCT ASSEMBLY

1

Place the part A upper crossbar on the part B lower crossbar.

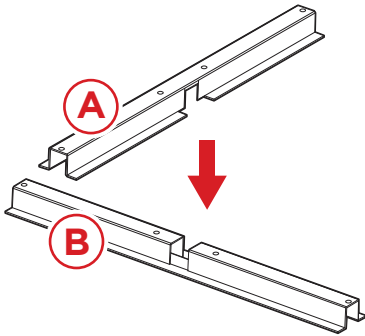

2

Attach the part C rotating base to the crossbars with four part 1 screws and four part 2 washers.

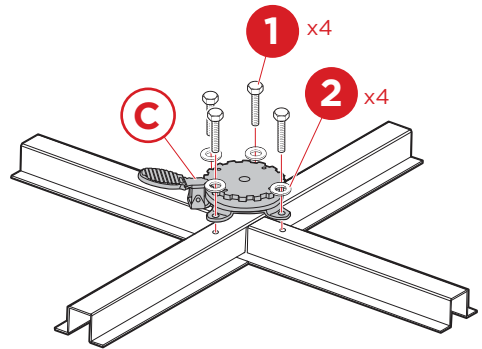

3

Place the part D pole on the rotating base and attach it with four part 1 screws and four part 2 washers. Slide the part E base cover over the pole.

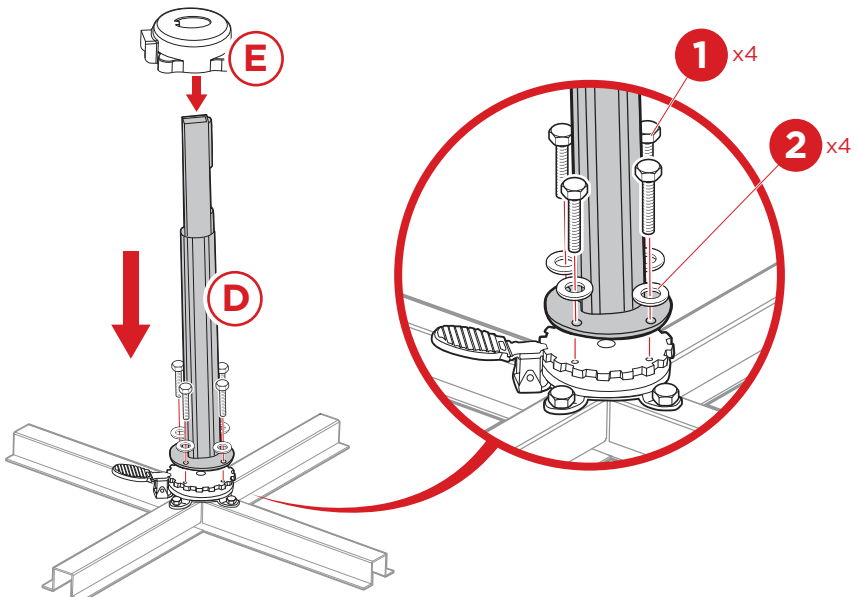

PRODUCT ASSEMBLY

4

Slide the part F sleeve onto the pole.

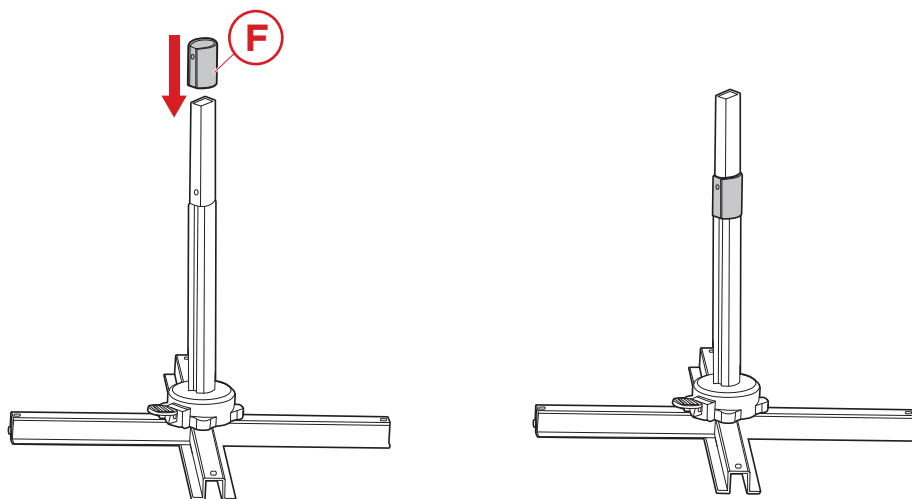

5

Firmly insert the part G umbrella onto the pole and secure it with the part 3 knob.

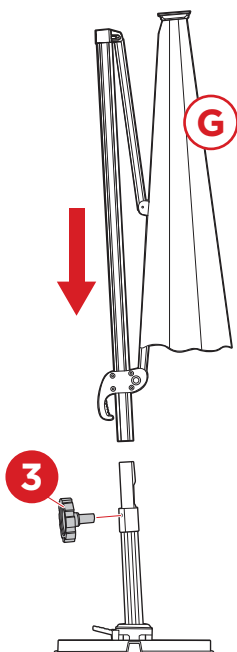

PRODUCT ASSEMBLY

6

Insert the part H crank. Compress the handle and move the arm up.
Release the handle to lock it in your desired position.
Slowly turn the crank clockwise to open the canopy.

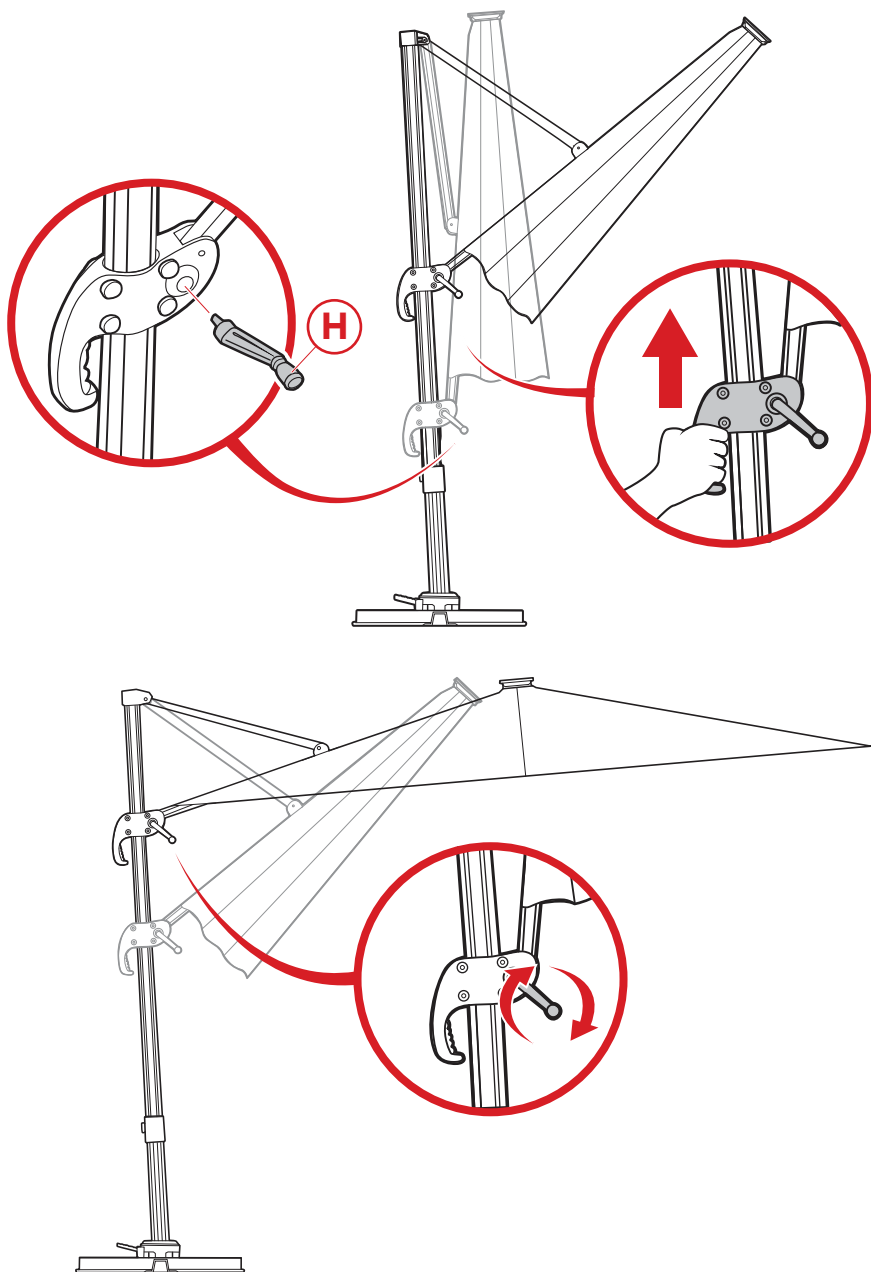

OPERATING INSTRUCTIONS

Opening Canopy

1. Compress the handle and move the arm up.
2. Release the handle to lock it in your desired position.
3. Slowly turn the crank clockwise to open the canopy.

Adjusting Tilt

1. Compress the handle and move the arm up/down to adjust the tilt angle of the umbrella.
2. Release the handle to lock it in your desired position.

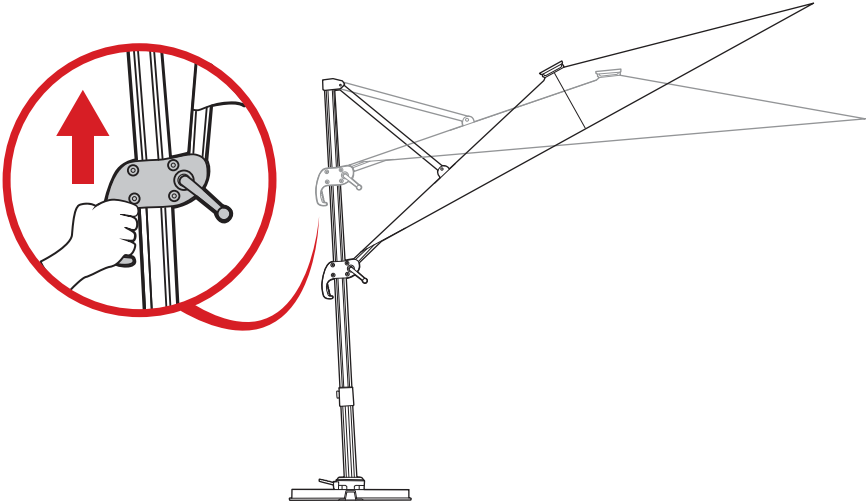

Rotating Canopy

- Compress the pedal on the rotating base to rotate the canopy.

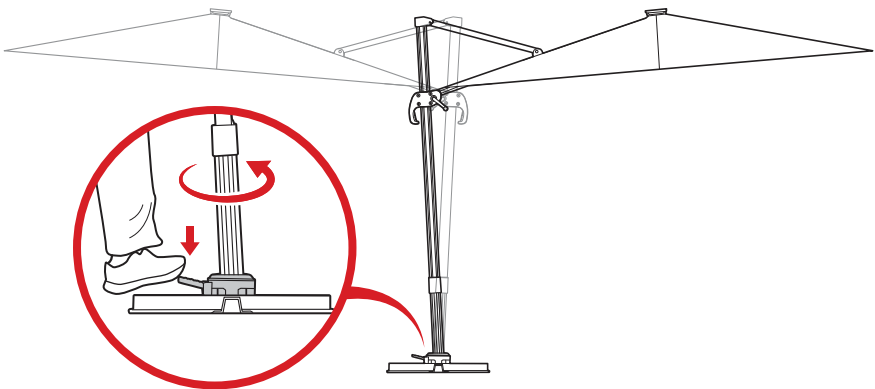

OPERATING INSTRUCTIONS

Closing Canopy

- Turn the crank counterclockwise to close the canopy.

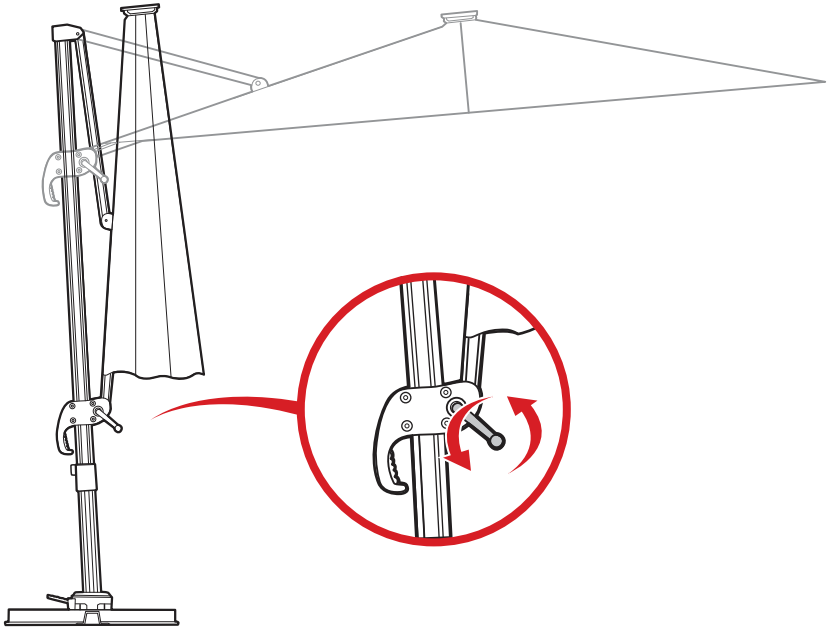

USAGE TIPS

- Umbrella base weights are not included. Do not use this umbrella without umbrella base weights.
- Place umbrella on a stable and level surface.
- Umbrella is suitable for rain showers and light wind.
- Do not use umbrella in inclement weather, such as snow, heavy rain, thunderstorms, or strong wind.
- Close the canopy when umbrella is not in use.

STORAGE

1. Close the canopy. Compress the handle and move the arm all the way down.
2. Fasten the strap around the canopy.
3. Assemble the part I cover pole. Slide the pole into the part J cover.
4. Place cover and pull the string to close the zipper. Remove the cover pole.
5. Store umbrella in a dry area shielded from the weather.

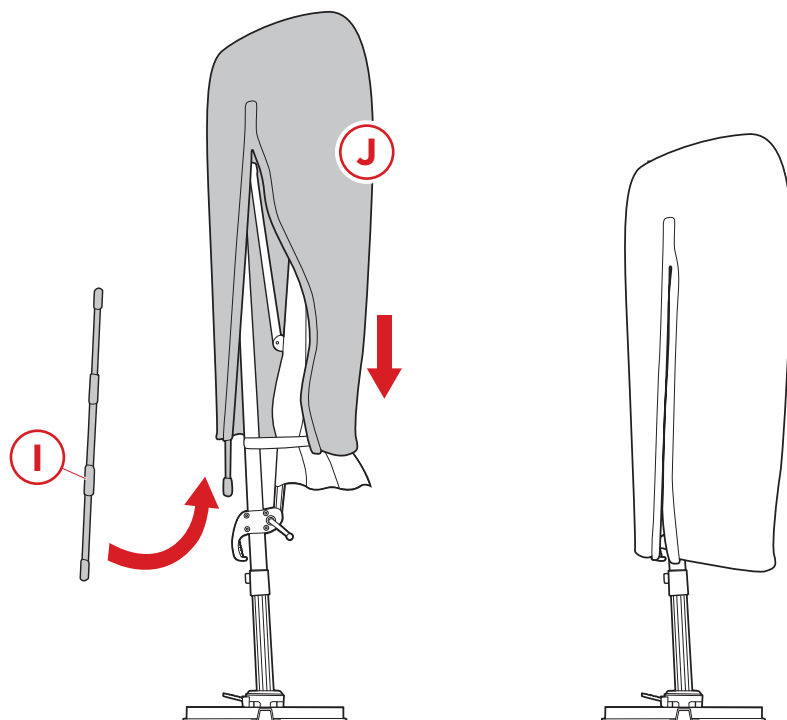

CLEANING

- Wipe clean with mild detergent, warm water, and a soft cloth.
- Do not clean with abrasive materials, harsh detergents, or corrosive liquids like gasoline or acetone.

Earn points while you shop. Join today!

bestchoiceproducts
rewards

Join | Earn | Redeem

Give your friends 15% off their first order! For each successful referral you'll receive 100 points.

bestchoiceproducts.com



HELP CENTER



Question about your product? We're here to help. Visit us at:

help.bestchoiceproducts.com



Chat Support



Product Inquiry



Orders FAQ



Product Assembly



Returns & Refunds

PRODUCT WARRANTY INFORMATION

All items can be returned for any reason within 60 days of the receipt and will receive a full refund as long as the item is returned in its original product packaging and all accessories from its original shipment are included. All returned items will receive a full refund back to the original payment method. All returned items will not be charged a re-stocking fee.

All returned items require an RA (Return Authorization) number, which can only be provided by a Best Choice Products Customer Service Representative when the return request is submitted. Items received without an RA may not be accepted or may increase your return processing time. Once an item has been received by Best Choice Products, refunds or replacements will be processed within 5 business days.

All returns must be shipped back to the Best Choice Products Return Center at the customer's expense. If the reason for return is a result of an error by Best Choice Products then Best Choice Products will provide a pre-paid shipping label via email. Boxes for return shipping will not be provided by Best Choice Products, and is the customer's responsibility to either use the original shipping boxes or purchase new boxes.

Pictures may be required for some returns to ensure an item is not damaged prior to its return. Items returned are not considered undamaged until they are received by Best Choice Products and verified as such. All damages to items are the customer's responsibility until the item has been received by and acknowledge by Best Choice Products as undamaged.

WARNING

Manufacturer and seller expressly disclaim any and all liability for personal injury, property damage or loss, whether direct, indirect, or incidental, resulting from the incorrect attachment, improper use, inadequate maintenance, or neglect of this product.