

AIR HANDLING UNIT



Reneo-Fit D 100 S14
Reneo-Fit D 100-E S14

EN **USER'S MANUAL**

CONTENTS

Safety requirements..... 3
Purpose..... 5
Delivery set..... 5
Designation key..... 5
Technical data..... 6
Design and operating principle 8
Mounting and set-up..... 10
Connection to power mains 14
Technical maintenance..... 15
Troubleshooting..... 17
Storage and transportation regulations..... 17
Manufacturer’s warranty..... 18
Certificate of acceptance..... 19
Seller information..... 19
Installation certificate..... 19
Warranty card..... 19

This user’s manual is a main operating document intended for technical, maintenance, and operating staff. The manual contains information about purpose, technical details, operating principle, design, and installation of the Reneo-Fit D 100(-E) S14 unit and all its modifications. Technical and maintenance staff must have theoretical and practical training in the field of ventilation systems and should be able to work in accordance with workplace safety rules as well as construction norms and standards applicable in the territory of the country.

SAFETY REQUIREMENTS

This unit is not intended for use by persons (including children) with reduced physical, sensory or mental capabilities, or lack of experience and knowledge, unless they have been given supervision or instruction concerning use of the unit by a person responsible for their safety. Children should be supervised to ensure that they do not play with the unit.

This appliance can be used by children aged from 8 years and above and persons with reduced physical, sensory or mental capabilities or lack of experience and knowledge if they have been given supervision or instruction concerning use of the appliance in a safe way and understand the hazards involved.

Cleaning and user maintenance shall not be made by children without supervision.

Children shall not play with the appliance.

This appliance incorporates an earth connection for functional purposes.

Connection to the mains must be made through a disconnecting device, which is integrated into the fixed wiring system in accordance with the wiring rules for design of electrical units, and has a contact separation in all poles that allows for full disconnection under overvoltage category III conditions.

Ensure that the unit is switched off from the supply mains before removing the guard.

Precautions must be taken to avoid the back-flow of gases into the room from the open flue of gas or other fuel-burning appliances.

The appliance may adversely affect the safe operation of appliances burning gas or other fuels (including those in other rooms) due to back flow of combustion gases. These gases can potentially result in carbon monoxide poisoning. After installation of the unit the operation of flued gas appliances should be tested by a competent person to ensure that back flow of combustion gases does not occur.

Do not attach the product to the support using glue or adhesives. Use only the fastening method specified in the «User's manual».

All operations described in this manual must be performed by qualified personnel only, properly trained and qualified to install, make electrical connections and maintain ventilation units.

Do not attempt to install the product, connect it to the mains, or perform maintenance yourself. This is unsafe and impossible without special knowledge.

Disconnect the power supply prior to any operations with the unit.

All user's manual requirements as well as the provisions of all the applicable local and national construction, electrical, and technical norms and standards must be observed when installing and operating the unit.

Disconnect the unit from the power supply prior to any connection, servicing, maintenance, and repair operations.

Connection of the unit to power mains is allowed by a qualified electrician with a work permit for the electric units up to 1000 V after careful reading of the present user's manual.

Check the unit for any visible damage of the impeller, the casing, and the grille before starting installation. The casing internals must be free of any foreign objects that can damage the impeller blades.

While mounting the unit, avoid compression of the casing! Deformation of the casing may result in motor jam and excessive noise.

Misuse of the unit and any unauthorised modifications are not allowed.

Do not expose the unit to adverse atmospheric agents (rain, sun, etc.).

Transported air must not contain any dust or other solid impurities, sticky substances, or fibrous materials.

Do not use the unit in a hazardous or explosive environment containing spirits, gasoline, insecticides, etc.

Do not close or block the intake or extract vents in order to ensure the efficient air flow.

Do not sit on the unit and do not put objects on it.

The information in this user's manual was correct at the time of the document's preparation.

The Company reserves the right to modify the technical characteristics, design, or configuration of its products at any time in order to incorporate the latest technological developments.

Never touch the unit with wet or damp hands.

Never touch the unit when barefoot.

BEFORE INSTALLING ADDITIONAL EXTERNAL DEVICES, READ THE RELEVANT USER MANUALS.



THE PRODUCT MUST BE DISPOSED SEPARATELY AT THE END OF ITS SERVICE LIFE.

DO NOT DISPOSE THE UNIT AS UNSORTED DOMESTIC WASTE

PURPOSE

The unit is designed to ensure continuous mechanical air exchange in houses, offices, hotels, cafes, conference halls, and other utility and public spaces as well as to recover the heat energy contained in the air extracted from the premises to warm up the filtered stream of intake air.

The unit is not intended for organizing ventilation in swimming pools, saunas, greenhouses, summer gardens, and other spaces with high humidity.

Due to the ability to save heating energy by means of energy recovery, the unit is an important element of energy-efficient premises.

The unit is a component part and is not designed for stand-alone operation. It is rated for continuous operation.

Transported air must not contain any flammable or explosive mixtures, evaporation of chemicals, sticky substances, fibrous materials, coarse dust, soot and oil particles or environments favourable for the formation of hazardous substances (toxic substances, dust, pathogenic germs).

DELIVERY SET

Name	Number
Air handling unit	1 pc.
User's manual	1 pc.
Control panel	1 pc.
Installation kit	1 pc.
Packing box	1 pc.

DESIGNATION KEY

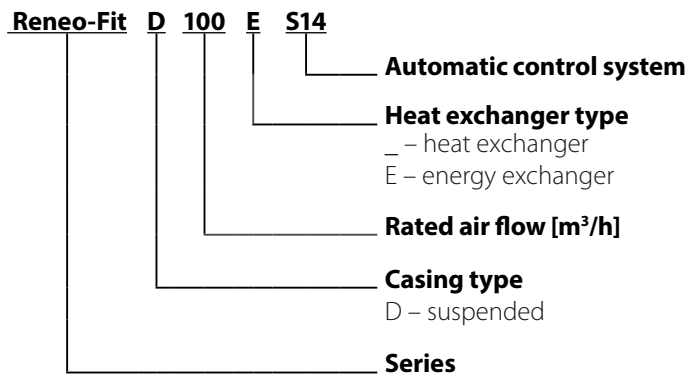

TECHNICAL DATA

The unit is designed for indoor application with the ambient temperature ranging from +1 °C up to +40 °C and relative humidity up to 60 % without condensation. In cold, damp rooms, there is a possibility of freezing or condensation inside and outside the casing.

In order to prevent condensation on the internal walls of the unit, it is necessary that the surface temperature of the casing is 2-3 °C above the dew point temperature of the transported air.

The unit should be operated continuously, and in cases where ventilation is not necessary, reduce the air flow of the fans to a minimum (20%). This will ensure a favorable indoor climate and reduce the amount of condensation inside the unit, which can damage electronic components. Never use the unit for dehumidification, for example, of new buildings.

The unit is rated as a Class I electrical appliance.

Hazardous parts access and water ingress protection rating:

IP22 for the unit connected to the air ducts

IP44 for the unit motors

The unit design is constantly being improved, thus some models may be slightly different from those described in this manual.

TECHNICAL DATA

Model	Reneo-Fit D 100 S14	Reneo-Fit D 100-E S14
Power supply voltage [V 50/60 Hz]	1 ~ 230	
Max. power [W]	38,07	
Maximum unit current [A]	0,340	
Max. air flow [m ³ /h]	130	
Sound pressure level at 3 m distance [dBA]	32	
Transported air temperature [°C]	-23...+40	
Casing material	Expanded polypropylene	
Exhaust filter filtration class	G4 / Coarse >60 %	
Supply filter filtration class	G4 / Coarse >60 % (option F7 / ePM1 60 %)	
Diameter of connecting pipes [mm]	100/125	
Weight [kg]	8	
Heat recovery efficiency [%]	82-94 %	73-88 %
Heat exchanger type	Counter-flow	
Heat exchanger material	Polystyrene	Enthalpy
Energy saving class	A+	A

Overall and connecting dimensions

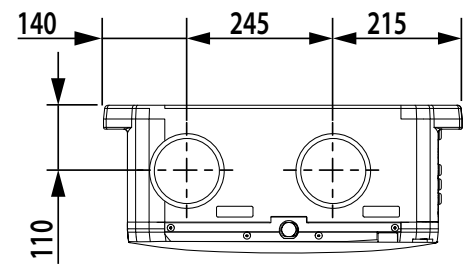
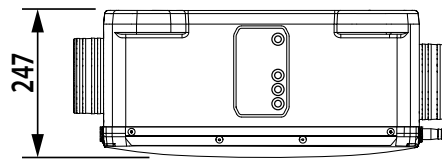
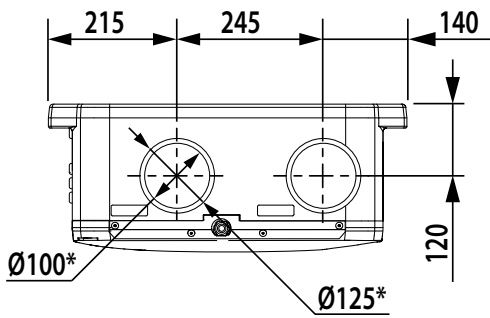
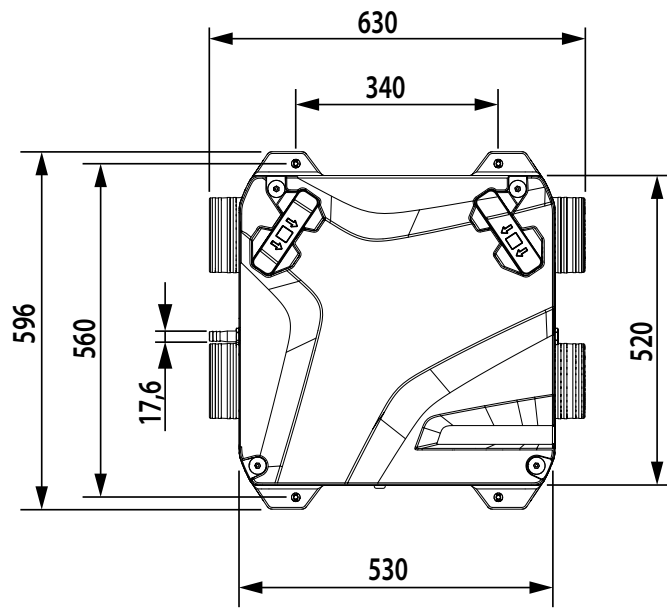

*The unit can be connected to a 100 mm or 125 mm air duct system.

100 mm air ducts are inserted into the connecting pipes, while 125 mm air ducts are put over the connecting pipes.

DESIGN AND OPERATING PRINCIPLE

The unit is housed in a sound-insulated casing (item 1).

The connecting pipes of the unit form a single structure with the unit casing.

The function of the connecting pipes (item 7) is indicated on the stickers on the unit casing.

The supply fan (item 10), exhaust fan (item 11) and heat exchanger (item 12) are also located inside the unit casing.

The function of the connecting pipes of the unit depends on the unit modification (left- or right-handed modification).

The product modification is determined by the location of the temperature sensor (item 14), the humidity sensor (item 13) and the connection of the motors in the control unit (item 8).

The location of the sensors and the function of the connecting pipes after the system has been assembled at the factory is shown in the image Reneo-Fit D 100(-E) L S14.

Bottom side of the casing is covered with a removable cover (item 2), which is fastened with 4 plastic screws (item 3).

Under the covers (item 5) there are the exhaust and supply air filters.

A control unit (item 3) is installed in the casing.

The power and control cables are pulled through cable glands (item 9).

Condensate is removed from the unit casing through a drainage pipe (item 6).

UNIT OPERATION MODE

Heat exchange: warm extract air from the room flows into the unit and is cleaned in the extract filter. Then the air is moved through the heat exchanger and is exhausted outside with the extract fan.

Cold fresh air from outside flows through the air duct into the unit, where it is cleaned by the supply filter.

Then the air flows through the heat exchanger and is moved to the room by the supply fan.

Supply air is heated in the heat exchanger due to transfer of the heat energy of warm and humid extract air to the cold fresh air.

The air streams remain separated in the heat exchanger.

Heat recovery minimizes heat losses, which reduces costs for space heating in the cold season.

Reneo-Fit D 100-E S14 units use an enthalpy heat exchanger to recover not only heat but also moisture.

In summer, the heat exchanger cools and dehumidifies the supply air, and in winter, it heats and humidifies it.

Water vapour condenses from the moist exhaust air and is absorbed by the heat exchanger plates.

The resulting moisture and heat are transferred to the supply air.

Defrosting: in order to protect against icing during cold seasons, the unit is equipped with an automatic defrosting mode controlled by readings of the defrosting temperature sensor located in the exhaust duct behind the heat exchanger.

The unit enters defrosting mode when the exhaust air temperature drops below +3 °C.

After increase of these temperatures the unit reverts to the previous operation mode.

In the defrosting mode, only the exhaust fan runs, the supply fan is switched off.

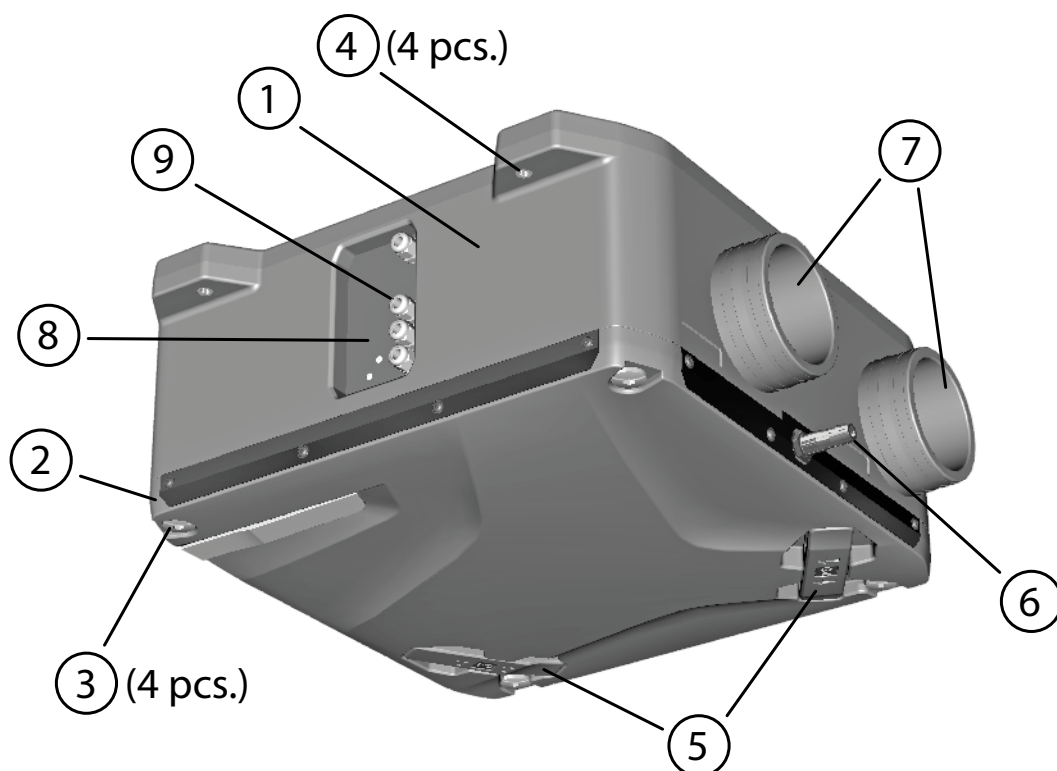

VIEW FROM THE SERVICE SIDE WITH THE COVER REMOVED

Reneo-Fit D 100(-E) R S14

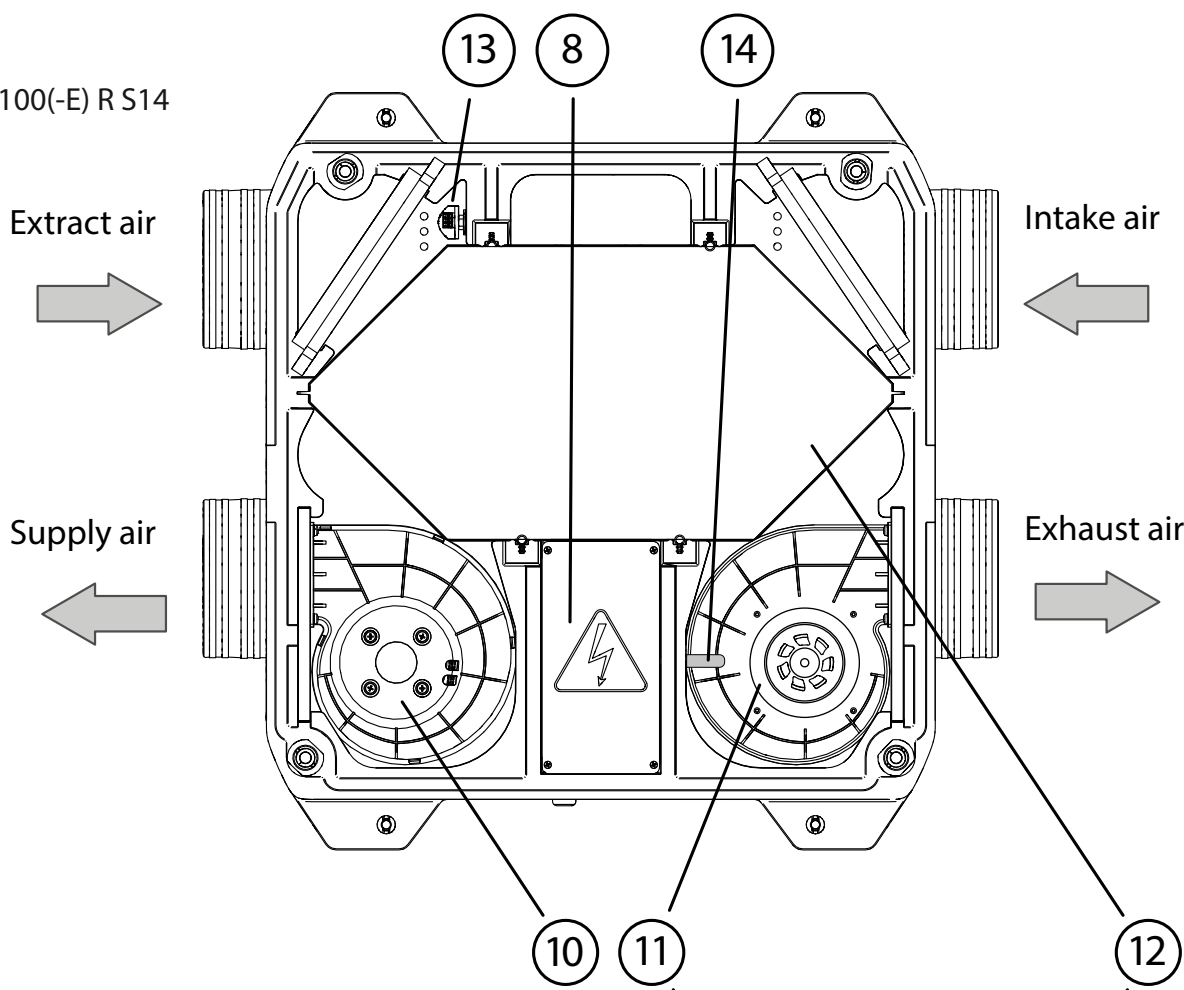

Reneo-Fit D 100(-E) L S14

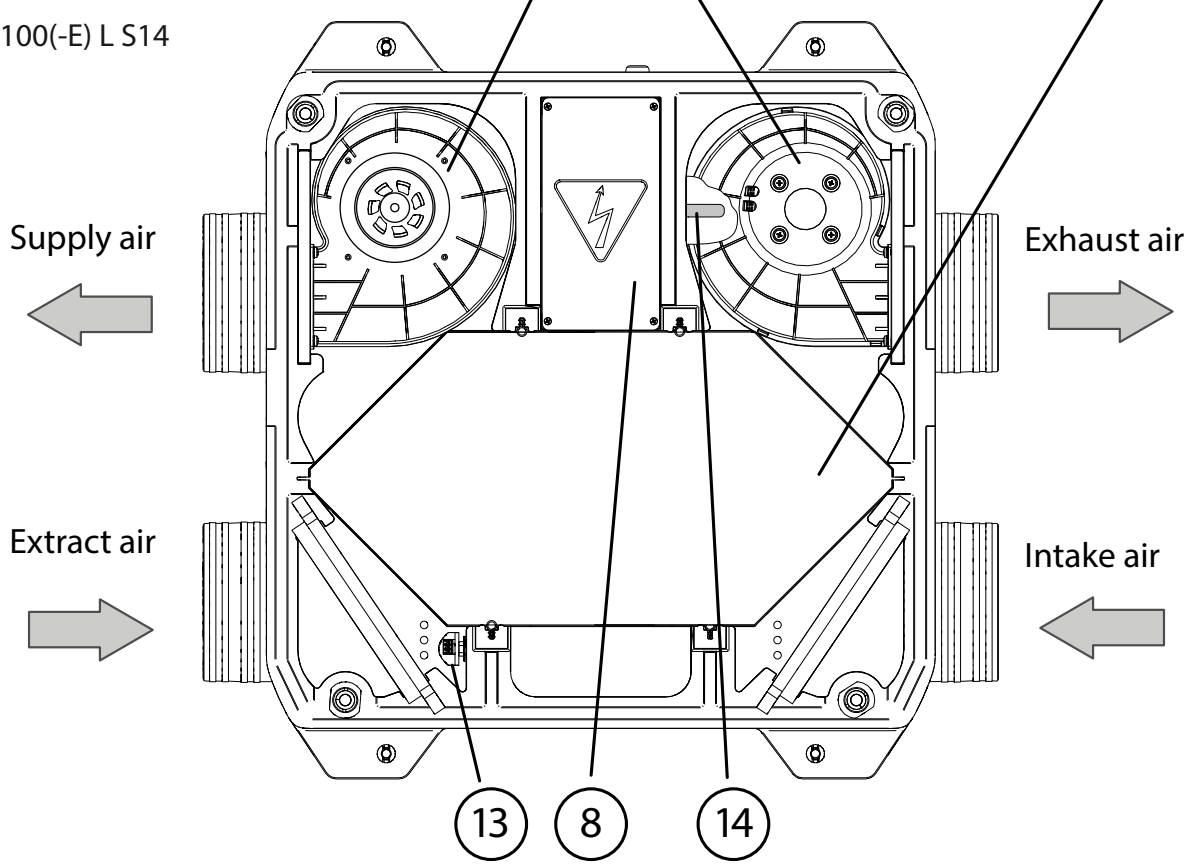

MOUNTING AND SET-UP

The units are fitted with connecting pipes for the connection of circular air ducts. 100 mm air ducts are inserted into the connecting pipes, while 125 mm air ducts are put over the connecting pipes. The unit is mounted in the ventilation system in accordance with the function of the connecting pipes. Functions of the connecting pipes of the factory-assembled unit are indicated on stickers..

WARNING!

- To reduce aerodynamic losses related to air flow turbulence, use shaped reducers in order to reduce or increase the cross-section of air ducts.
- To minimise turbulence-induced air pressure losses, connect the straight air duct sections on both sides of the unit. Minimum straight air duct length: equal to 1 air duct diameter on intake side and 3 air duct diameters on outlet side
- It is necessary to protect the internal parts of the unit from penetration of foreign objects. For example, install a grill with a cell side size of no more than 12.5 mm to prevent free access to the fan and foreign objects from entering the unit.
- The equipment and air ducts that are to be connected must have their own mounting bracket in order to avoid transferring their own weight loads to the unit.

The unit must be mounted so that it can be accessed for service purposes.

Enough space must be provided for the cover to completely remove.

Only ceiling mounting is allowed.

Mounting is performed at 4 points through the mounting holes.

It is recommended to use anchor threaded rods with nuts for fastening the unit.

Fasteners for the unit mounting are not included into delivery set and should be ordered separately.

While choosing fasteners consider the material of the mounting surface and the unit weight.

For selection of the fasteners for unit mounting please refer to a service technician.

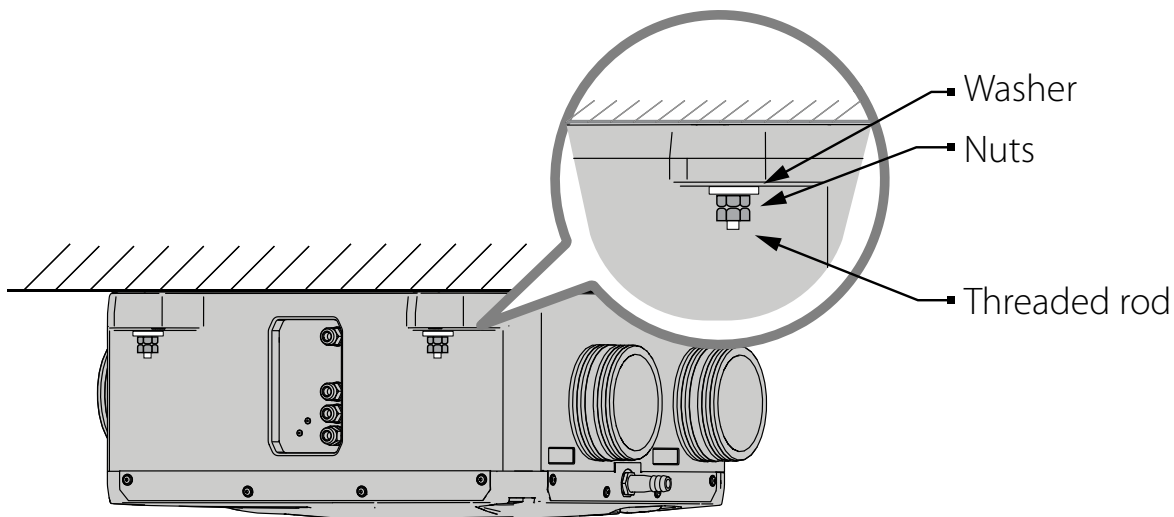

CHANGE OF THE UNIT MODIFICATION

In some cases, it may be necessary to reconfigure the unit to ensure a more efficient placement of equipment and communications. To do this, it is necessary to rearrange the temperature and humidity sensors inside the casing as shown in the figure in the section "Unit design and operating principle".

The motor connections in the control unit must also be changed.

To do this, you need to move the temperature sensor, humidity sensor and change the wiring of the fan motors in the control box.

Moving the temperature sensor

If you want to move the control unit before connecting the unit to the power supply and external devices, perform the below steps in the following order:

1. Place the unit on a surface with the removable cover facing up.
2. Remove the removable cover from the unit casing.
To do this, unscrew 4 plastic screws that secure the cover.
3. Open the control box cover as shown in the figure on the right.
4. Remove two screws that secure the chassis and remove the chassis from the control box.

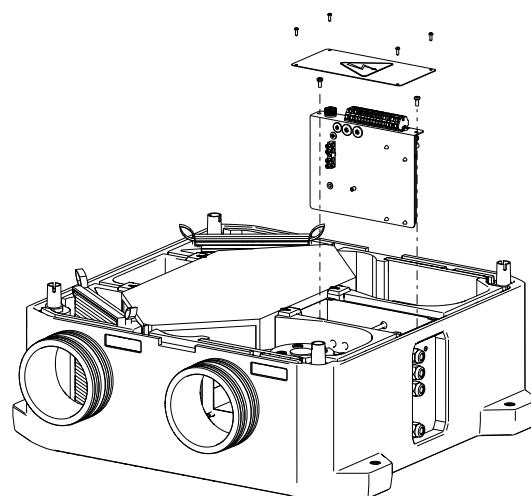

Temperature sensor position after assembly at the factory

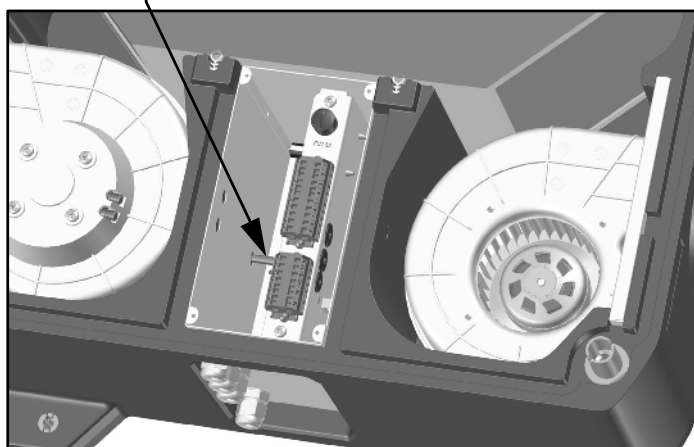

Temperature sensor position after moving it

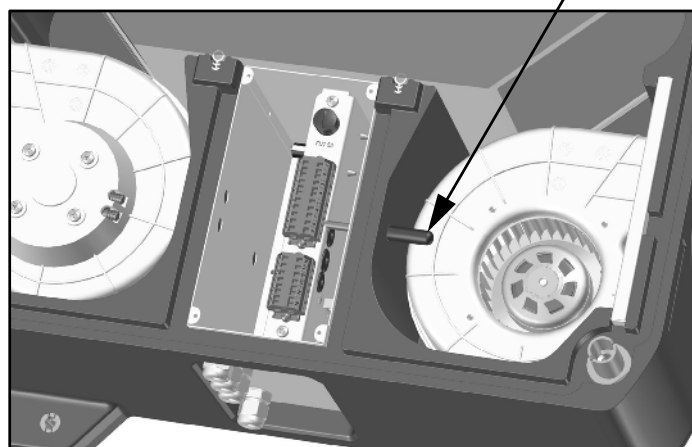

5. Remove the temperature sensor from the wall of the control box and insert it into the hole on the opposite side of the control box. Prior to doing so, make a hole in the expanded polypropylene partition with a suitable sharp tool through the hole in the metal casing of the control box.

6. Seal all openings using a sealant to prevent air leakage.

Moving the humidity sensor

To move the humidity sensor, follow these steps in sequence:

1. First follow the steps described in points 1, 2, 3 and 4 of the section "Moving the temperature sensor".
2. To gain easier access to the sensor, remove the filter as shown in the figure to the right.

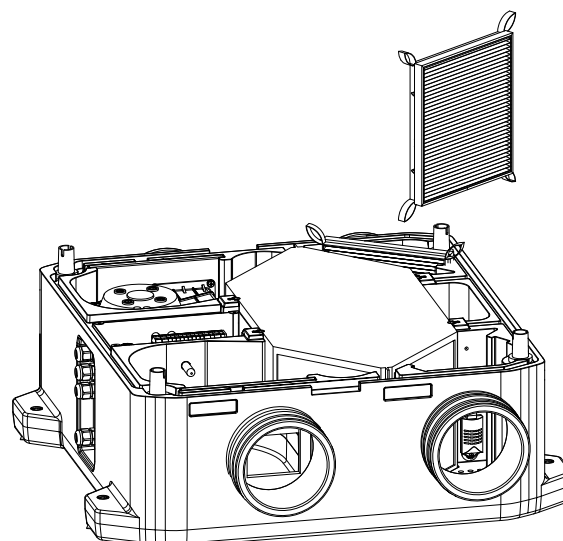

3. Mark the cable wires connected to the humidity sensor. Remember, photograph or write down the connection points of cables.
4. Pull the cable out to the opposite side of the unit casing. Remove it from the channel. Pull the cable inside the control box.
5. Use a suitable sharp tool to make a hole in the expanded polypropylene partition through the hole in the metal casing of the control box where one of the channels leading to the connecting pipe opposite the one next to the humidity sensor begins.
6. Push the cable through the new hole and route it through the channel leading to the new location of the sensor. Route the cable to the location of the humidity sensor.

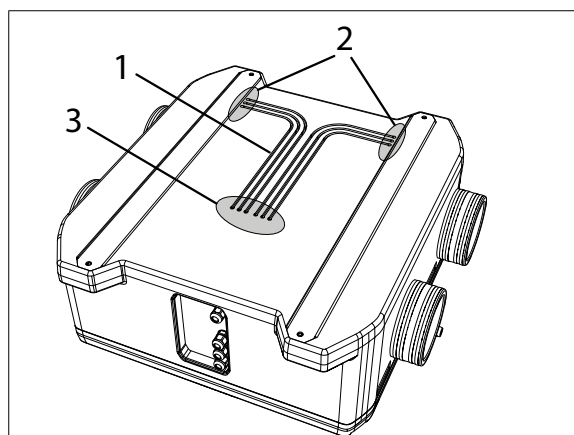

- 1 – channels for routing the sensor cable;
 2 – places for cable entry into the humidity sensor cavity;
 3 – places for cable entry into the control box cavity.

7. Remove the self-tapping screw that secures the humidity sensor. Unscrew the spiral dowel into which the screw was screwed.

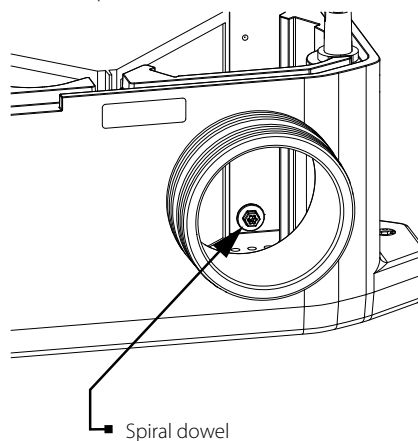
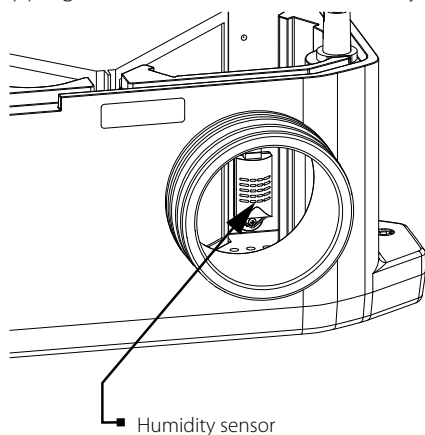

8. Screw the spiral dowel at the new location of the sensor. Fix the sensor there using a self-tapping screw. Connect the cable wires to the sensor terminals in the same order as they were connected before disassembly.
9. Seal all openings using a sealant to prevent air leakage. Reinstall the filters in their original positions.

Changing the motor connection

In case of changing the unit modification, the role of the fans in the automatic anti-icing protection of the unit changes. Therefore, the motor control cable connectors on the controller board must be reconnected.

To do this, follow these steps in sequence:

1. First follow the steps described in points 1, 2, 3 and 4 of the section "Moving the temperature sensor".
2. Disconnect the motor control cable connectors and rearrange them as shown in the figure below.
3. Reinstall the chassis and secure it with the screws in the reverse order.
4. Reinstall the control box cover and the chassis cover.

After completing all the steps described above, reattach the stickers showing connecting pipes function to the new locations as shown in the figure in the section "Unit design and operating principle" (Reneo-Fit D 100(-E) R S14).

It is also necessary to move the condensate drain pipe to the opposite side of the unit casing and close its hole with a plug.

Diagram of connecting the motor control cables to the controller board after moving

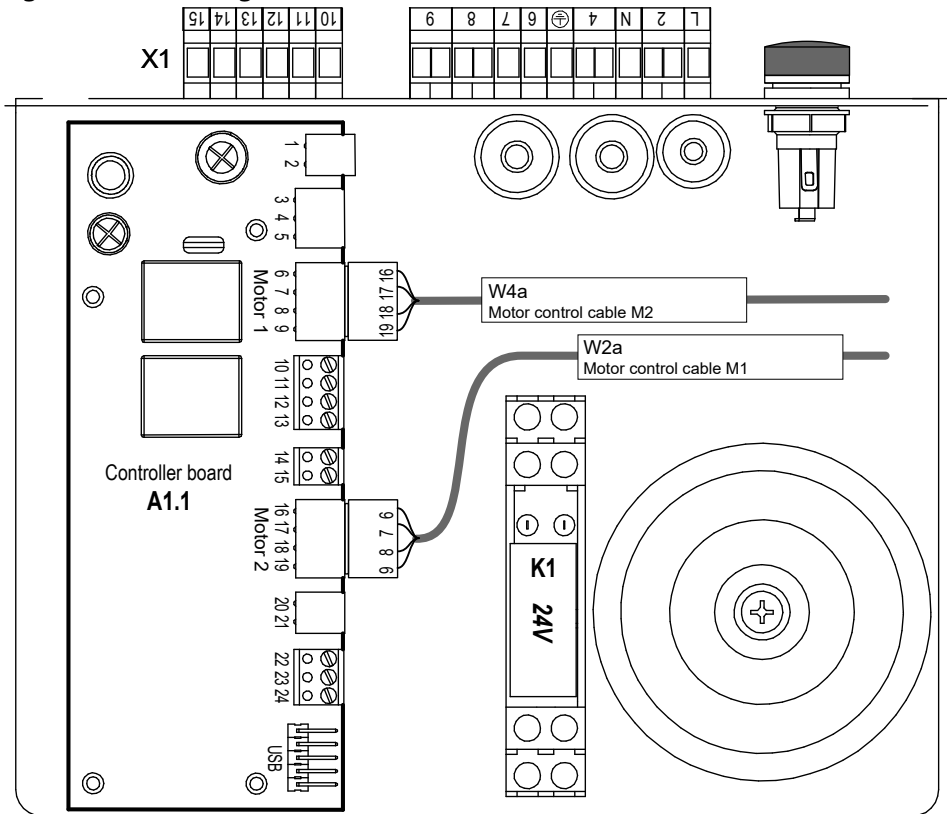

Condensate drainage

Condensate drainage is required in systems with heat recovery.

WARNING! The drain pipe on the outdoor air supply side is intended for the removal of condensate, which forms during cooling of the supply air in the heat exchanger when the unit operates in a warm, humid climate conditions. The decision whether or not to install this drain pipe should be made by the designer based on the operating conditions of the unit and the local climate. If in doubt or if there is a risk of condensation formation, a drain pipe on the outdoor supply air side must be installed for safety reasons. The opening for the drain pipes is located in the unit cover.

The unit is fitted with a drain pipe that removes condensate outside the casing. U-traps must be connected to the drain pipe. Connect the drain pipe, U-trap and the sewage system with metal, plastic or rubber connection pipes. A schematic representation of the condensate drainage system is shown below. The unit is shown in the left-handed modification.

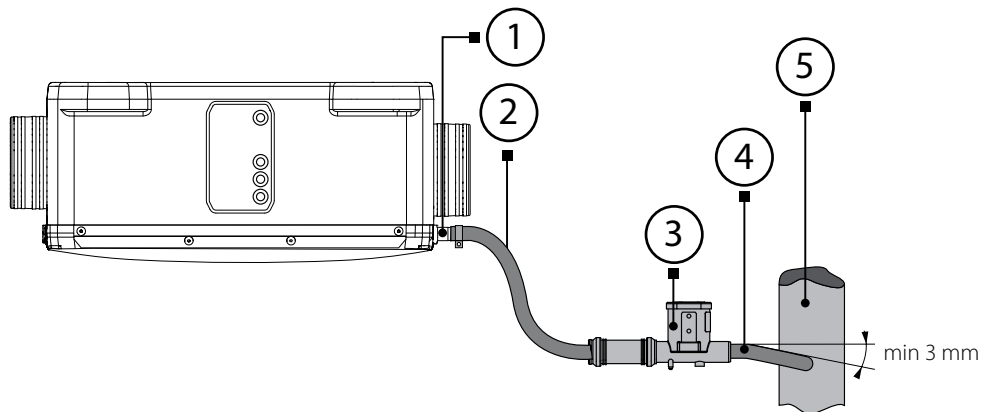

1 – drain pipe; 2 – connecting pipe; 3 – U-trap; 4 – connecting pipe; 5 – sewage system.

Before operating the unit, make sure that the water is drained into the sewerage system. Fill up the U-trap with water before using it.

CONNECTION TO POWER MAINS

The connection must be made using durable, insulated and heat-resistant conductors (cables, wires).
 The external power input must be equipped with an automatic circuit breaker built into the stationary wiring to open the circuit in the event of overload or short-circuit.
 The position of the external circuit breaker must ensure free access for quick unit power-off.
 The trip current of the automatic circuit breaker must exceed the maximum current consumption of the unit (refer to the "Technical data" section or to the unit label).
 It is recommended to select the rated current of the circuit breaker from the standard series, following the maximum current of the connected unit.
 The circuit breaker is not included in the delivery set.
 The conductors' cross section value is indicative. The actual wire cross section selection must be based on the type of wire, its maximum allowable heating, insulation, length and installation method.
 To connect the power supply and external devices, unscrew the four plastic screws on the cover of the control unit and remove the cover, as shown in the figure in the "Mounting and set-up" section.
 Route the power supply cable and the cables for connecting the control panel and other cables through the cable glands in the control box and connect them according to the wiring diagram.
 Wiring diagrams for power supply and external devices are shown in the figure below.

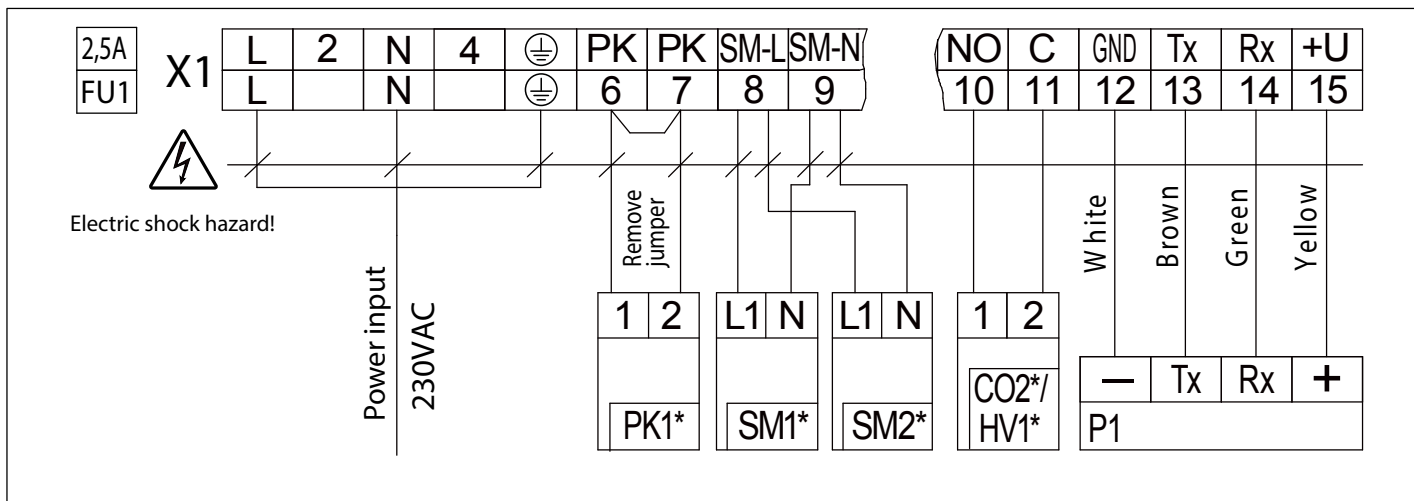

The interpretation of the designations and the characteristics of the connection cables are given in the table.

Designation	Name	Wire type	Note
P1	External control panel	4x0,25 mm ²	
CO ₂ */HV1*	CO ₂ sensor or humidity sensor	2x0,5 mm ²	
PK1*	Contact of fire alarm panel	2x0,75 mm ²	Remove jumper
SM1*/ SM2*	Supply / exhaust damper drive	2x0,75 mm ²	
FU1	Fuse		5x20, slow

* Is not included in the delivery set.

TECHNICAL MAINTENANCE

Maintenance operations of the unit are required 3-4 times per year.

They include general cleaning of the unit and the following operations:

1. Filter maintenance (3-4 times per year).

Dirty filters increase air flow resistance, which leads to a decrease in the supply of supply air to the room and creates preconditions for occurrence of faults. The filters require cleaning not less than 3-4 times per year. The filters may be cleaned with a vacuum cleaner.

After two consecutive cleanings the filters must be replaced. To change the filters, remove the filter covers (item 5 in the section "Unit design and operating principle"). Carefully remove the dirty filter. Install new filters and covers in reverse order. For new filters, contact the Seller.

2. Heat exchanger maintenance (once per year).

Some dust may accumulate on the heat exchanger even in case of regular maintenance of the filters. To maintain the high heat recovery efficiency, regular cleaning is required.

Before removing the heat exchanger, unscrew the 4 plastic screws and remove the cover. Remove heat exchanger from the unit and clean it with compressed air or a vacuum cleaner.

Reinstall the cleaned heat exchanger into the unit in the reverse order.

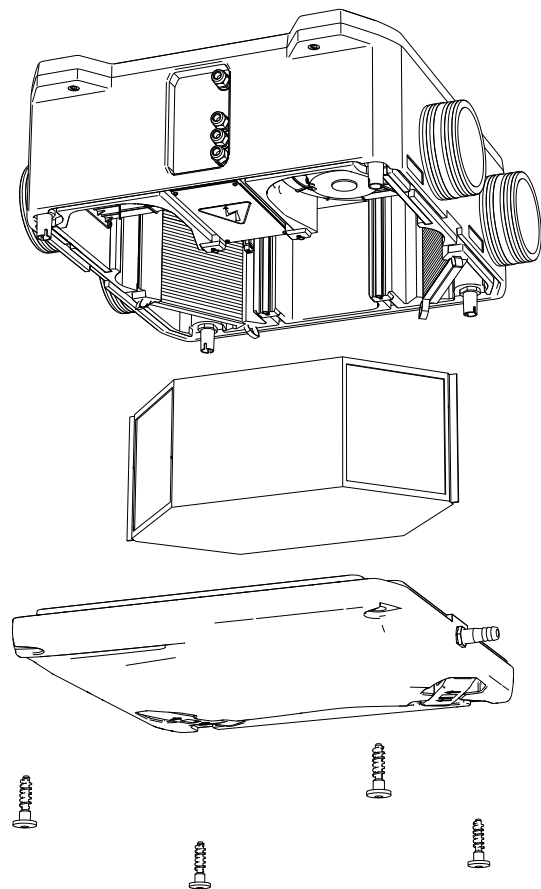
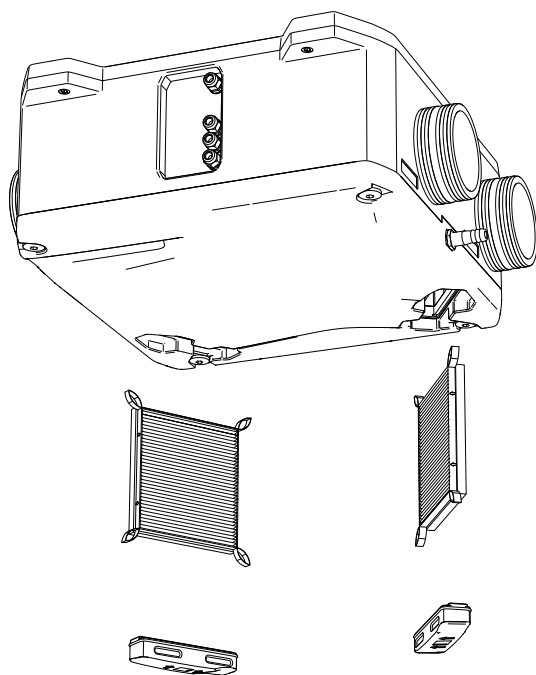

3. Fan maintenance (once per year).

Even in case of regular maintenance of the filters, some dust may accumulate inside the fans and reduce the fan performance and supply air flow.

Clean the fans with a soft cloth, brush, or using compressed air.

Do not use water, aggressive solvents, or sharp objects as they may damage the impeller.

4. Maintenance of air intake devices (twice per year).

The supply grille may get clogged with leaves and other objects, which reduces the unit performance and supply air delivery.

Check the supply grille twice per year and clean it as required.

5. Ductwork system maintenance (once in 5 years).

Even regular fulfilling of all the maintenance operations prescribed above may not completely prevent dirt accumulation in the air ducts, which leads to air pollution and reduces the unit capacity.

Duct maintenance means regular cleaning or replacement.

6. Control unit maintenance (as required).

The control unit is located inside of the unit casing.

For accessing the control unit remove the fixing screws on the panel and remove the control unit lid.

TROUBLESHOOTING

Problem	Possible reasons	Troubleshooting
The unit does not start.	No power supply.	Make sure the power supply line is connected correctly, otherwise troubleshoot a connection error.
	Jammed motor.	Disconnect the fan from power supply. Troubleshoot the motor jamming. Restart the unit.
	The fan has overheated.	Disconnect the fan from power supply. Eliminate the cause of overheating. Restart the unit.
Automatic circuit breaker tripping after the unit start-up.	Overcurrent as a result of short circuit in the electric circuit.	Switch off the unit. Contact the Seller.
Noise, vibration or reduced air flow.	The fan impeller is soiled.	Clean the impellers.
	The fan or casing screw connection is loose.	Tighten the screw connection of the fan or the casing against stop.
	The ventilation system components (air ducts, diffusers, louvre shutters, grilles) are clogged or damaged.	Clean or replace the ventilation system components (air ducts, diffusers, louvre shutters, grilles).

Make sure that the U-trap is filled with water and the drain pipes are frost protected.

If troubleshooting steps have failed, contact the Seller of the product.

In case of faults not described in the table, contact the Seller for further information.

STORAGE AND TRANSPORTATION REGULATIONS

- Store the unit in the manufacturer's original packaging box in a dry closed ventilated premise with temperature range from +5 °C to +40 °C and relative humidity up to 70 %.
- Storage environment must not contain aggressive vapors and chemical mixtures provoking corrosion, insulation, and sealing deformation.
- Use suitable hoist machinery for handling and storage operations to prevent possible damage to the unit.
- Follow the handling requirements applicable for the particular type of cargo.
- The unit can be carried in the original packaging by any mode of transport provided proper protection against precipitation and mechanical damage. The unit must be transported only in the working position.
- Avoid sharp blows, scratches, or rough handling during loading and unloading.
- Prior to the initial power-up after transportation at low temperatures, allow the unit to warm up at operating temperature for at least 3-4 hours.

MANUFACTURER'S WARRANTY

The product is in compliance with EU norms and standards on low voltage guidelines and electromagnetic compatibility. We hereby declare that the product complies with the provisions of Electromagnetic Compatibility (EMC) Directive 2014/30/EU of the European Parliament and of the Council, Low Voltage Directive (LVD) 2014/35/EU of the European Parliament and of the Council and CE-marking Council Directive 93/68/EEC. This certificate is issued following test carried out on samples of the product referred to above.

The manufacturer hereby warrants normal operation of the unit for 24 months after the retail sale date provided the user's observance of the transportation, storage, installation, and operation regulations. Should any malfunctions occur in the course of the unit operation through the Manufacturer's fault during the guaranteed period of operation, the user is entitled to get all the faults eliminated by the manufacturer by means of warranty repair at the factory free of charge. The warranty repair includes work specific to elimination of faults in the unit operation to ensure its intended use by the user within the guaranteed period of operation. The faults are eliminated by means of replacement or repair of the unit components or a specific part of such unit component.

The warranty repair does not include:

- routine technical maintenance
- unit installation/dismantling
- unit setup

To benefit from warranty repair, the user must provide the unit, the user's manual with the purchase date stamp, and the payment paperwork certifying the purchase. The unit model must comply with the one stated in the user's manual. Contact the Seller for warranty service.

The manufacturer's warranty does not apply to the following cases:

- User's failure to submit the unit with the entire delivery package as stated in the user's manual including submission with missing component parts previously dismantled by the user.
- Mismatch of the unit model and the brand name with the information stated on the unit packaging and in the user's manual.
- User's failure to ensure timely technical maintenance of the unit.
- External damage to the unit casing (excluding external modifications as required for installation) and internal components caused by the user.
- Redesign or engineering changes to the unit.
- Replacement and use of any assemblies, parts and components not approved by the manufacturer.
- Unit misuse.
- Violation of the unit installation regulations by the user.
- Violation of the unit control regulations by the user.
- Unit connection to power mains with a voltage different from the one stated in the user's manual.
- Unit breakdown due to voltage surges in power mains.
- Discretionary repair of the unit by the user.
- Unit repair by any persons without the manufacturer's authorization.
- Expiration of the unit warranty period.
- Violation of the unit transportation regulations by the user.
- Violation of the unit storage regulations by the user.
- Wrongful actions against the unit committed by third parties.
- Unit breakdown due to circumstances of insuperable force (fire, flood, earthquake, war, hostilities of any kind, blockades).
- Missing seals if provided by the user's manual.
- Failure to submit the user's manual with the unit purchase date stamp.
- Missing payment paperwork certifying the unit purchase.



FOLLOWING THE REGULATIONS STIPULATED HEREIN WILL ENSURE A LONG AND TROUBLE-FREE OPERATION OF THE UNIT



USER'S WARRANTY CLAIMS SHALL BE SUBJECT TO REVIEW ONLY UPON PRESENTATION OF THE UNIT, THE PAYMENT DOCUMENT AND THE USER'S MANUAL WITH THE PURCHASE DATE STAMP

CERTIFICATE OF ACCEPTANCE

Unit Type	Air handling unit
Model	
Serial Number	
Manufacture Date	
Quality Inspector's Stamp	

SELLER INFORMATION

Seller	
Address	
Phone Number	
E-mail	
Purchase Date	
This is to certify acceptance of the complete unit delivery with the user's manual. The warranty terms are acknowledged and accepted.	
Customer's Signature	

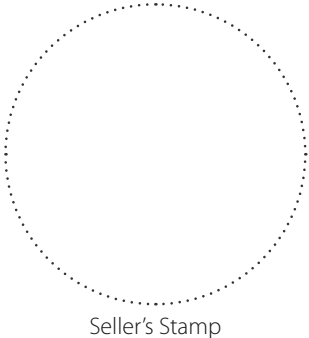

Seller's Stamp

INSTALLATION CERTIFICATE

The _____ unit is installed pursuant to the requirements stated in the present user's manual.	
Company name	
Address	
Phone Number	
Installation Technician's Full Name	
Installation Date:	Signature:
The unit has been installed in accordance with the provisions of all the applicable local and national construction, electrical and technical codes and standards. The unit operates normally as intended by the manufacturer.	
Signature:	

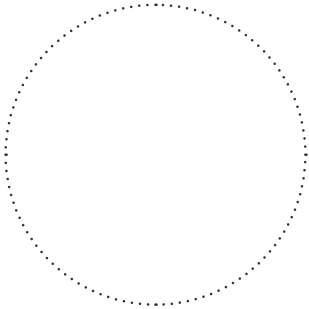

Installation Stamp

WARRANTY CARD

Unit Type	Air handling unit
Model	
Serial Number	
Manufacture Date	
Purchase Date	
Warranty Period	
Seller	

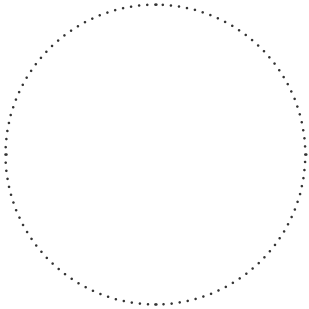

Seller's Stamp

