

Owner's Manual & Safety Instructions

Save This Manual Keep this manual for the safety warnings and precautions, assembly, operating, inspection, maintenance and cleaning procedures. Write the product's serial number in the back of the manual near the assembly diagram (or month and year of purchase if product has no number). Keep this manual and the receipt in a safe and dry place for future reference.

21i

BRAUN™

COMMERCIAL LIGHT



Visit our website at: <http://www.harborfreight.com>
Email our technical support at: productsupport@harborfreight.com

58077

When unpacking, make sure that the product is intact and undamaged. If any parts are missing or broken, please call 1-888-866-5797 as soon as possible.

Copyright© 2021 by Harbor Freight Tools®. All rights reserved.
No portion of this manual or any artwork contained herein may be reproduced in any shape or form without the express written consent of Harbor Freight Tools. Diagrams within this manual may not be drawn proportionally. Due to continuing improvements, actual product may differ slightly from the product described herein. Tools required for assembly and service may not be included.

⚠ WARNING

Read this material before using this product. Failure to do so can result in serious injury. **SAVE THIS MANUAL.**

Electrical Rating	120-277 VAC / 50/60 Hz / 50W
-------------------	------------------------------

IMPORTANT SAFETY INFORMATION

TO PREVENT SERIOUS INJURY AND DEATH FROM ELECTRIC SHOCK: THIS PRODUCT MUST BE INSTALLED IN ACCORDANCE WITH THE APPLICABLE INSTALLATION CODE BY A PERSON FAMILIAR WITH THE CONSTRUCTION AND OPERATION OF THE PRODUCT AND THE HAZARDS INVOLVED.

Before you begin installing, servicing, or maintenance of this product follow these general precautions.

Read These Instructions Completely and Carefully

1. **SAFETY:** This fixture must be wired in accordance with the national electrical code and applicable local codes and ordinances. Proper grounding is required to insure personal safety. Carefully observe the grounding procedure under installation section. All work should be done by a qualified electrician.
2. **RISK OF ELECTRIC SHOCK** - Disconnect power at fuse or circuit breaker before installing or servicing.
3. **RISK OF PERSONAL INJURY** - Fixture may be damaged and/or unstable if not installed properly. Tighten all fixture components to their recommended torque values.
4. **WARNING:** Make certain power is **OFF** before starting installation or attempting any maintenance.
5. To reduce the risk of death, personal injury, or property damage from fire, electrical shock, falling parts, cuts/abrasions, and other hazards please read all warnings and instructions included with and on this product prior to installation.
6. Do not mount against flammable surfaces.
7. This product is intended to be used outdoors, and be subject to the elements; such as rain and snow and we recommend it to be mounted at least 6' 6" off the ground.
8. This LED product must be powered directly to a switched circuit.
9. Make sure that where this fixture will be mounted is structurally sound and that it will support the weight of this fixture.
10. This product should not be used in areas with limited ventilation or high ambient temperatures.
11. This product is intended to be connected to a properly installed and grounded UL listed junction box.

WARNING! RISK OF ELECTRICAL SHOCK

1. Verify voltage is 120-277 VAC before installing.
2. All wiring connections should be capped with UL listed wire connectors.

CAUTION! RISK OF PRODUCT DAMAGE

1. Never connect fixture with power on.
2. Do not mount or support product in a manner that can cut the outer wire jacket or damage the wire insulation.
3. Avoid covering LED products with insulation, foam, or other materials that will prevent convection or conduction cooling.
4. Never connect an LED product directly to dimmer packs, occupancy sensors, timing devices, or other related control devices, unless individual product.
5. LED products are polarity sensitive, ensure proper polarity before installation.
6. Electrostatic Discharge (ESD) can cause damage to LED products. Wear personal grounding equipment during installation and service of the product.
7. Do not touch the individual electronic components, it may cause ESD (Electronic Discharge), shorten lamp life or alter performance.

CAUTION! RISK OF INJURY

1. Wear gloves and safety glasses at all times when removing fixture from carton, installing or servicing the product.
2. Avoid direct eye exposure to the light source while it is on.
3. LED LIGHTS ARE EXTREMELY BRIGHT, UNDER NO CIRCUMSTANCES SHOULD YOU LOOK DIRECTLY INTO AN LED LIGHT, THIS MAY CAUSE IRREPARABLE DAMAGE TO THE EYES.
4. Please dispose of packaging materials and account for all small parts as these can be hazardous to small children.

WARNING! RISK OF BURN

1. Allow fixture to cool completely before handling.
2. Do not exceed maximum voltage marked on the label.
3. Keep combustible and other materials that can burn away from the light, lamp, and lens.

General Warnings

1. Assemble only according to these instructions. Improper assembly can create hazards.
2. Wear ANSI-approved safety goggles and heavy-duty work gloves during assembly.
3. Keep assembly area clean and well lit.
4. Keep bystanders out of the area during assembly.
5. Do not assemble when tired or when under the influence of alcohol, drugs or medication.
6. This product is not a toy. Do not allow children to play with or near this item.
7. Use as intended only.
8. Inspect before every use; do not use if parts are loose or damaged.
9. People with pacemakers should consult their physician(s) before installation. Electromagnetic fields in close proximity to heart pacemaker could cause pacemaker interference or pacemaker failure.
10. Maintain product labels and nameplates. These carry important safety information. If unreadable or missing, contact Harbor Freight Tools for a replacement.



SAVE THESE INSTRUCTIONS.

Installation Instructions



Read the **ENTIRE IMPORTANT SAFETY INFORMATION** section at the beginning of this document including all text under subheadings therein before set up or use of this product.

DANGER! TO PREVENT SERIOUS INJURY AND DEATH FROM ELECTRIC SHOCK: Disconnect power supply to circuit at breaker box and mark that breaker clearly to ensure it is not turned on during installation.

1. Determine the mounting location. Position the Light in the general direction of the desired light coverage. **Verify that installation surface has no hidden utility lines before drilling or driving screws.**
2. Remove the Rear Housing by removing two Door Screws located on the side of the Light.
5. Connect the Rear Housing to the wall.
 - a. **If connecting to a junction box** (sold separately):
 - Attach junction box to the wall.
 - Remove pre-cast locators at the back of Rear Housing.
 - Attach Rear Housing to the junction box using four screws (sold separately). Tighten securely.

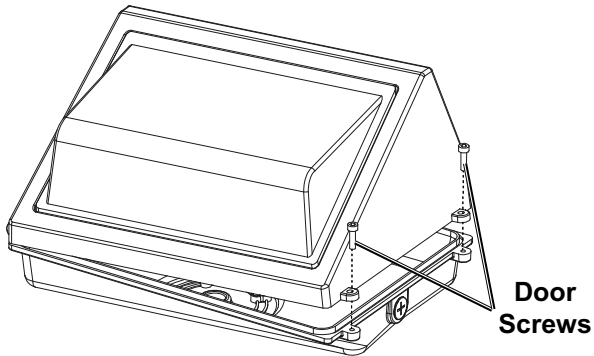

3. Carefully disconnect the Cable from Light to Rear Housing, then lift the Light off the side hinge of the Rear Housing.

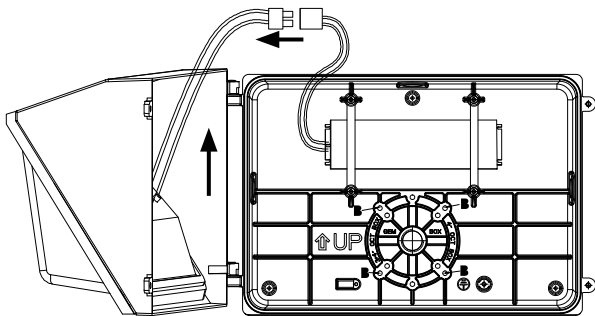

4. Wire Light to power source, see *Wiring Light to Power Source*, page 6.

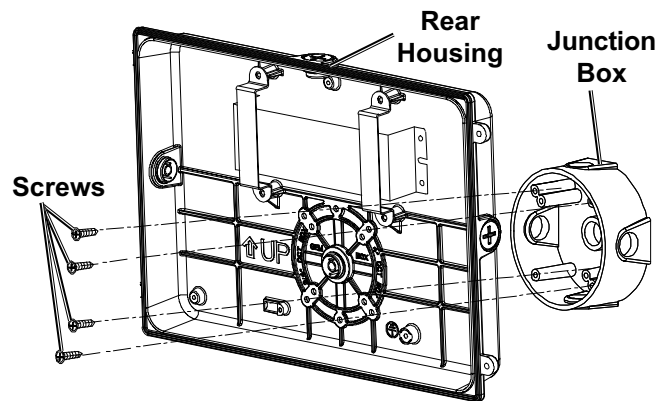

BRAUN™

b. If connecting directly to the wall:

- Using the Rear Housing as a template, drill three mounting holes on the wall.

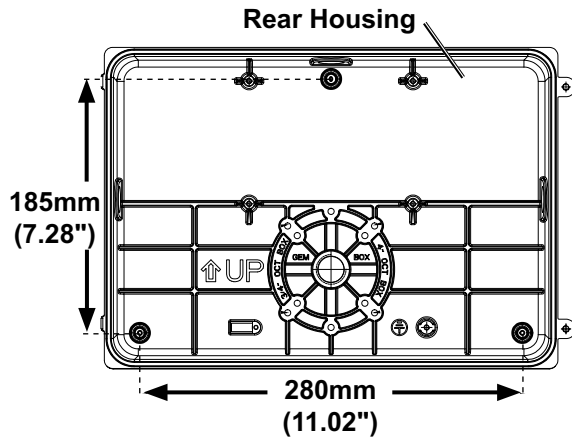

- Connect the Rear Housing to the wall using three screws (sold separately). Be sure the screws are appropriate for the material they are screwing into.
- Tighten screws and seal screw heads with appropriate waterproofing sealant (sold separately).

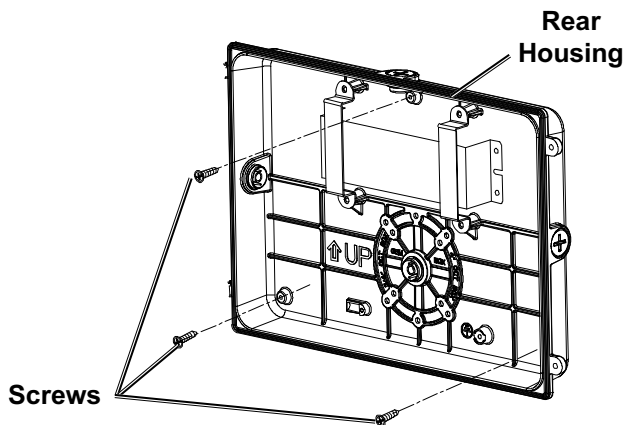

6. Reconnect the Cable and Light to the Rear Housing. Make sure the cable is fully connected.
7. Before closing the Light door, remove the two Drain Plugs from the bottom of the Light housing.

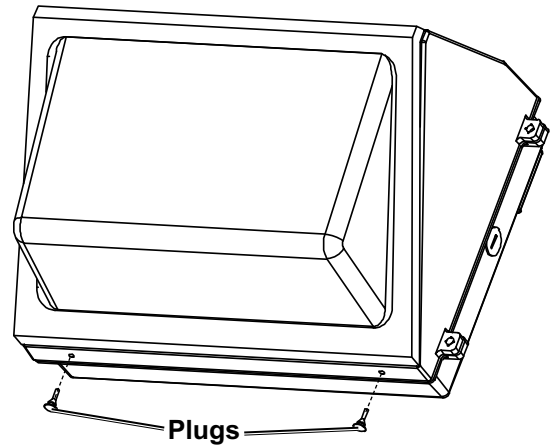

8. Close the Light door and secure it by reconnecting the two door Screws removed in Step 2.

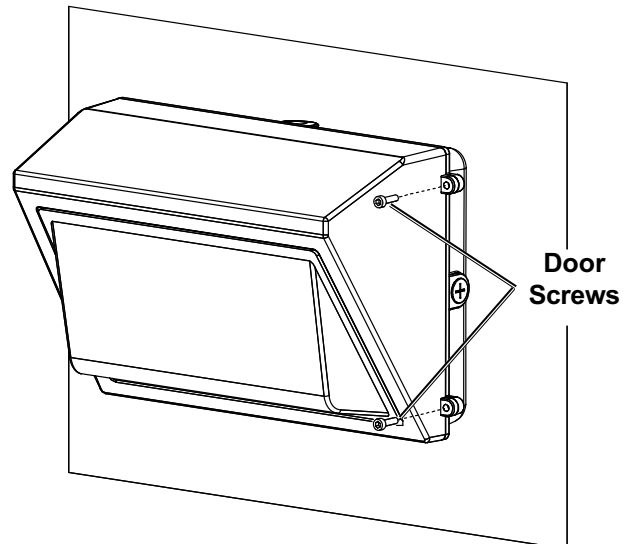

9. Reconnect power and verify the Light illuminates.

BRAUN™

Wiring Light to Power Source

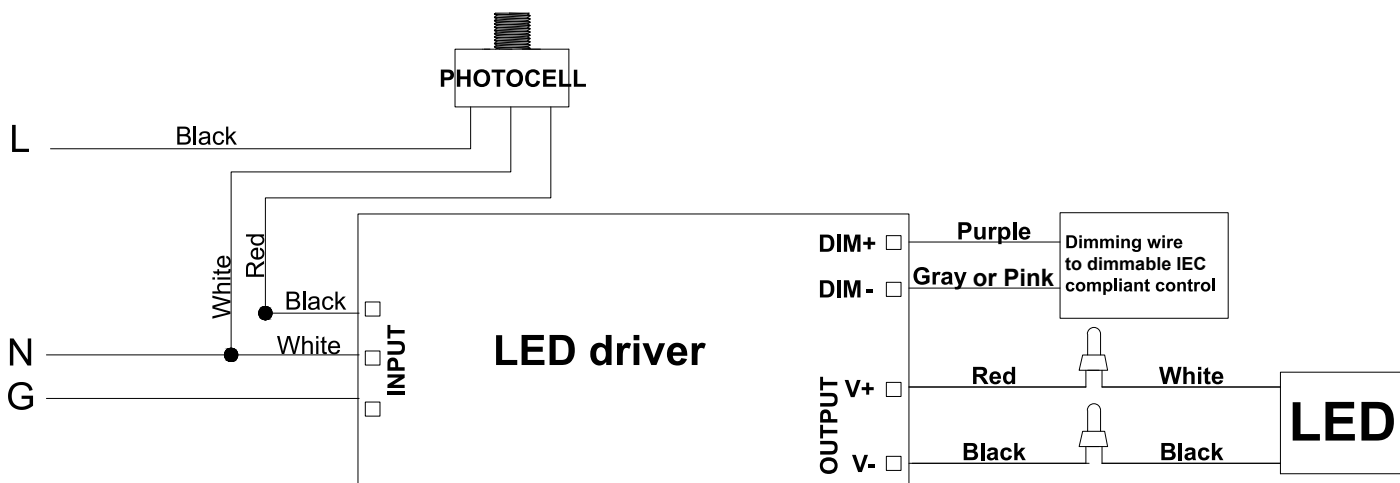

PLEASE READ THE FOLLOWING CAREFULLY

THE MANUFACTURER AND/OR DISTRIBUTOR HAS PROVIDED THE PARTS LIST AND ASSEMBLY DIAGRAM IN THIS DOCUMENT AS A REFERENCE TOOL ONLY. NEITHER THE MANUFACTURER OR DISTRIBUTOR MAKES ANY REPRESENTATION OR WARRANTY OF ANY KIND TO THE BUYER THAT HE OR SHE IS QUALIFIED TO MAKE ANY REPAIRS TO THE PRODUCT, OR THAT HE OR SHE IS QUALIFIED TO REPLACE ANY PARTS OF THE PRODUCT. IN FACT, THE MANUFACTURER AND/OR DISTRIBUTOR EXPRESSLY STATES THAT ALL REPAIRS AND PARTS REPLACEMENTS SHOULD BE UNDERTAKEN BY CERTIFIED AND LICENSED TECHNICIANS, AND NOT BY THE BUYER. THE BUYER ASSUMES ALL RISK AND LIABILITY ARISING OUT OF HIS OR HER REPAIRS TO THE ORIGINAL PRODUCT OR REPLACEMENT PARTS THERETO, OR ARISING OUT OF HIS OR HER INSTALLATION OF REPLACEMENT PARTS THERETO.

Record Serial Number Here: _____

Note: If product has no serial number, record month and year of purchase instead.

Note: Some parts are listed and shown for illustration purposes only, and are not available individually as replacement parts. Specify UPC 193175470829 when ordering parts.

Parts List and Diagram

Part	Description	Qty
1	Frame	1
2	Lens	1
3	Reflector	1
4	Screw M3x5	8
5	LED Board	1
6	Door Screw M5x16	2
7	Heat Sink	1
8	Screw M4x10	6

Part	Description	Qty
9	Bracket Screw M4x16	4
10	Bracket	2
11	LED Driver	1
12	Bubble Level	1
13	Gasket	1
14	Rear Housing	1
15	Photocell	1
16	1/2" Knockout	3

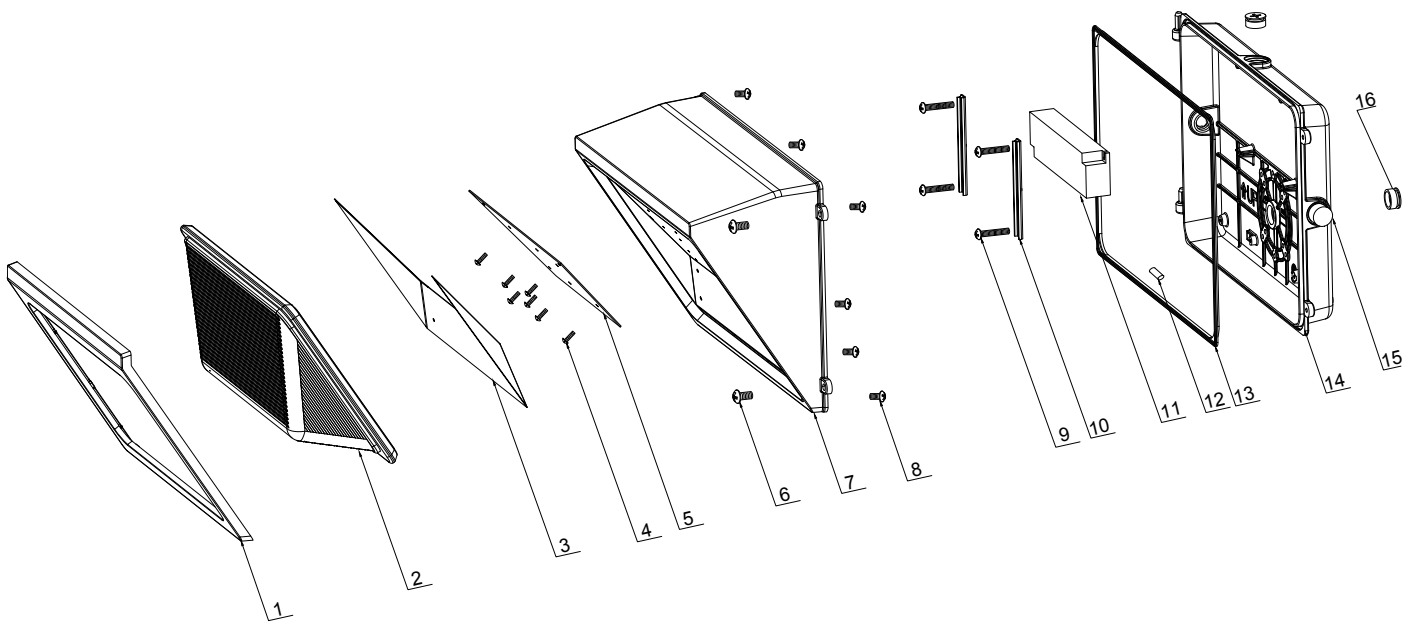

Limited 90 Day Warranty

Harbor Freight Tools Co. makes every effort to assure that its products meet high quality and durability standards, and warrants to the original purchaser that this product is free from defects in materials and workmanship for the period of 90 days from the date of purchase. This warranty does not apply to damage due directly or indirectly, to misuse, abuse, negligence or accidents, repairs or alterations outside our facilities, criminal activity, improper installation, normal wear and tear, or to lack of maintenance. We shall in no event be liable for death, injuries to persons or property, or for incidental, contingent, special or consequential damages arising from the use of our product. Some states do not allow the exclusion or limitation of incidental or consequential damages, so the above limitation of exclusion may not apply to you. THIS WARRANTY IS EXPRESSLY IN LIEU OF ALL OTHER WARRANTIES, EXPRESS OR IMPLIED, INCLUDING THE WARRANTIES OF MERCHANTABILITY AND FITNESS.

To take advantage of this warranty, the product or part must be returned to us with transportation charges prepaid. Proof of purchase date and an explanation of the complaint must accompany the merchandise. If our inspection verifies the defect, we will either repair or replace the product at our election or we may elect to refund the purchase price if we cannot readily and quickly provide you with a replacement. We will return repaired products at our expense, but if we determine there is no defect, or that the defect resulted from causes not within the scope of our warranty, then you must bear the cost of returning the product.

This warranty gives you specific legal rights and you may also have other rights which vary from state to state.

BRAUN™

26541 Agoura Road • Calabasas, CA 91302 • 1-888-866-5797