

# SPACE EXPLORATION COLLECTION

## 6" 150/1200mm Planet Dobson Telescope

Art. No. 9800760

150/1200 (6") · f/8

Parabolic Newtonian Reflector





## DANGER!

Solar observation only by using the included solar filter and in combination with the dedicated telescope. The solar filter must be mounted in front of the lens, i.e., before the sunlight enters the telescope.

**BEFORE EVERY SOLAR OBSERVATION:**

Remove the optical finderscope from the telescope tube to avoid unintentional looking at the sun!

## SOLAR FILTER INSTRUCTIONS:

Fig. 1



**Remove optical finderscope!**



Fig. 2

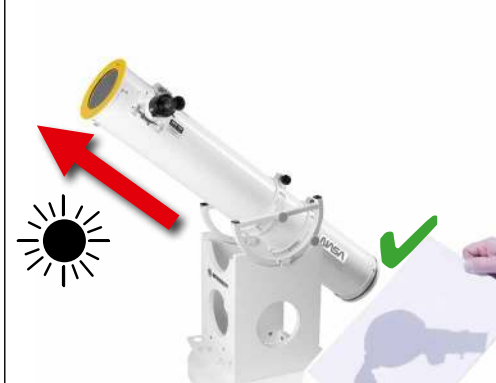

### Important safety information

- Check the solar filter before each solar observation to ensure it is undamaged. Hold it up to a bright light source to detect cracks and/or holes. Do not use the telescope for solar observation if the solar filter is even slightly damaged. In this case, contact the manufacturer to obtain the right spare parts.
- Always use the solar filter provided when observing the sun. Ensure it is correctly installed on this telescope according to the instructions. The usage of the solar filter is only recommended in combination with this telescope.
- Never look into the sun through an eyepiece/telescope without any certified solarfilter. A moonfilter can never be used to observe the sun. A moonfilter is only suitable for observing the moon. The solarfilter must be mounted onto the telescope aperture, not onto the eyepiece. Otherwise the ray of light bundled by the lens immediately destroys the filter foil and can instantly cause eye damage or even complete blindness.
- Before each sun observation, check that the sun filter is firmly in place. Accidental detachment from the lens opening can cause immediate and permanent eye damage and blindness.
- If the sun filter cannot be mounted firmly enough on the tube, improve the fit by applying several self-adhesive felt strips or similar between the sun filter and the lens aperture. Never use the solar filter if it cannot be properly attached to the telescope. In such a case, always contact our customer service first.
- Be careful when observing the sun. Even a brief glance through the unprotected lens may lead to major eye damage or even complete blindness.
- Children must not be allowed to use the telescope to look at the sun, even if the right filter is fitted. Children must be under constant supervision.
- Never leave the optics unattended. Children and inexperienced adults may use the telescope for solar observation without suitable safety measures and blind themselves.
- Do not observe without interruption. Make frequent breaks (approx. every three minutes).
- Do not look at the sun after an eye operation or other eye ailment without medical approval.
- Waves / creases in the foil are normal and not a product defect.
- Do not expose the device to high temperatures.

### Installing the solar filter (Fig. 1)

1. Make sure the optics is turned away from the sun before and during the installation.
2. Hold the filter only on the external frame (1). Never touch the foil (2) to avoid any damages on it.
3. Insert the filter carefully with the clamp ring (3) first into the free opening (4) of the telescope.

### NOTE!

Turn away the optics from the sun before removing the solar filter. The extremely powerful bundling of light and heat by a bare lens may damage the lens adhesive in the eyepiece.

### Pointing the telescope at the sun

Start with checking the solar filter - it has to be completely intact and firmly installed onto the telescope. It is very easy to point the telescope

to the sun - just hold a piece of white paper about 20cm behind the telescope tube and watch the shadow on the paper. See Fig. 2. Point the telescope to the approximate position of the sun and watch the outline of the telescope shadow on the paper. Move the telescope until the area of the shadow is at its minimum. Now the sun can be observed through the telescope with the 20mm eyepiece. For finding the sun, please only use the 20mm eyepiece and without the Barlow lens. After you have centered the sun in the field of view of the eyepiece you can increase power by using the Barlow lens to see more details.

### Attaching and using the solar viewfinder (accessory depends on model)

Depending on the telescope type purchased and the scope of delivery, a special solar viewfinder is used. It works according to a simple projection method and can therefore be used safely to find the sun. To do this, remove the LED viewfinder for night observation from the optical tube and insert the solar viewfinder into the holder. Of course, this solar viewfinder must be adjusted with the telescope on one axis before first use. To do this, adjust the sun in the telescope as described above using the cast shadow method and then center the point-shaped sun projection with the viewfinder adjustment screws in the center of the viewfinder's lens.

### Notes on use: Eyepiece magnification

Please use only the 20 mm eyepiece supplied for solar observation either by itself or together with the 2x Barlow lens to limit maximum magnification to 18x or 35x. Greater magnification, e.g. using the 4 mm eyepiece, yields blurred solar images. This is a design feature and not a defect.

### Maintenance and cleaning

Clean the foil only if it is absolutely necessary! For cleaning use a lint-free and soft cloth and moisten it with a little water. Then clean the foil with the cloth very carefully and without pressure. Note that the foil is very sensitive and it must not be used even with minor damages!

To avoid premature aging of the filter, it is recommended to store the filter in a light-protected environment when it is not in use.

### Declaration of Conformity

Product Type: Solar Filter  
Product Name: Solar Filter for Telescopes  
Filter category: E15, E16

Bresser GmbH declares that the above-named product corresponds to the following directives and relevant standards in its conception and design as well in the version marketed by us.

Directive:	Harmonized Standards:
PPE 89/686/EEC	EN 1836:2005, cl. 4.1.4.4
./.	ISO 12312-2:2015

This declaration is no longer valid in the event of a change to the product which has not been coordinated with us.

Bresser GmbH, Gutenbergstr. 2, D-46414 Rhede, Germany



## Allgemeine Warnhinweise · General Safety Informations · Avertissements généraux Algemene veiligheid informatie · Avvertenze generali · Advertencias generales de seguridad Informações gerais de segurança · Общие предупреждения

DE



**Diese Bedienungsanleitung ist als Teil des Gerätes zu betrachten. Lesen Sie vor der Benutzung des Geräts aufmerksam die Sicherheitshinweise und die Bedienungsanleitung. Bewahren Sie diese Bedienungsanleitung für die erneute Verwendung zu einem späteren Zeitpunkt auf. Bei Verkauf oder Weitergabe des Gerätes ist die Bedienungsanleitung an jeden nachfolgenden Besitzer/Benutzer des Produkts weiterzugeben.**

### **GEFAHR von Körperschäden!**

Schauen Sie mit diesem Gerät niemals direkt in die Sonne oder in die Nähe der Sonne. Es besteht ERBLINDUNGSGEFAHR!

Kinder sollten das Gerät nur unter Aufsicht benutzen. Verpackungsmaterialien (Plastiktüten, Gummibänder, etc.) von Kindern fernhalten! Es besteht ERSTICKUNGSGEFAHR!

### **BRANDGEFAHR!**

Setzen Sie das Gerät – speziell die Linsen – keiner direkten Sonneneinstrahlung aus! Durch die Lichtbündelung könnten Brände verursacht werden.

### **GEFAHR von Sachschäden!**

Bauen Sie das Gerät nicht auseinander! Wenden Sie sich im Falle eines Defekts bitte an Ihren Fachhändler. Er nimmt mit dem Service-Center Kontakt auf und kann das Gerät ggf. zwecks Reparatur einschicken.

GB



**These operating instructions are to be considered a component of the device. Please read the safety instructions and the operating instructions carefully before use. Keep these instructions for renewed use at a later date. When the device is sold or given to someone else, the instruction manual must be provided to the new owner/user of the product.**

### **RISK of physical injury!**

Never look through this device directly at or near the sun. There is a risk of BLINDING YOURSELF!

Children should only use this device under supervision. Keep packaging materials (plastic bags, rubber bands, etc.) away from children. There is a risk of SUFFOCATION.

### **Fire/Burning RISK!**

Never subject the device - especially the lenses - to direct sunlight. Light ray concentration can cause fires and/or burns.

### **RISK of material damage!**

Never take the device apart. Please consult your dealer if there are any defects. The dealer will contact our service centre and send the device in for repair if needed.

FR



**Le présent mode d'emploi doit être considéré comme faisant partie intégrante de l'appareil. Avant d'utiliser l'appareil, veuillez lire attentivement les consignes de sécurité et le mode d'emploi. Conservez celui-ci afin de pouvoir le réutiliser ultérieurement le cas échéant. En cas de revente ou de cession de l'appareil, le mode d'emploi doit être remis à tout propriétaire ou utilisateur suivant du produit.**

### **RISQUE de blessures corporelles!**

Avec cet appareil, ne regardez jamais directement vers le soleil ou à proximité du soleil. DANGER DE DEVENIR AVEUGLE !

Les enfants ne devraient utiliser l'appareil que sous surveillance. Gardez hors de leur portée les matériaux d'emballage (sachets en plastique, élastiques etc.) ! DANGER D'ÉTOUFFEMENT !

### **DANGER D'INCENDIE !**

Ne laissez jamais l'appareil – et surtout les lentilles – exposé directement aux rayons du soleil ! L'effet de loupe pourrait provoquer des incendies.

### **DANGER de dommage sur le matériel !**

Ne démontez jamais l'appareil ! En cas d'endommagement, adressez-vous à votre revendeur. Il prendra contact avec le centre de service et pourra, le cas échéant, envoyer l'appareil au service de réparations.

NL



**Deze gebruiksaanwijzing maakt deel uit van het apparaat. Lees vóór het eerste gebruik van het apparaat de veiligheidsinstructies en de gebruiksaanwijzing aandachtig door. Bewaar deze gebruiksaanwijzing voor later gebruik. Wanneer het apparaat wordt verkocht of doorgegeven, dient de gebruiksaanwijzing aan de volgende eigenaar / gebruiker van het product te worden overgedragen.**

### **GEVAAR voor lichamelijke letsel!**

Kijk met dit apparaat nooit direct in de zon of in de buurt van de zon. Uw kind kan zo VERBLIND raken!

Kinderen dienen het apparaat uitsluitend onder toezicht te gebruiken. Houd verpakkingsmateriaal (plastic zakken, elastiek, enz.) ver van kinderen! Uw kind kan daardoor STIKKEN!

### **GEVAAR Voor brand!**

Stel het apparaat – en vooral de lenzen – niet bloot aan direct zonlicht! Door de lichtbundeling kan brand worden veroorzaakt.

### **GEVAAR voor schade aan het materiaal!**

Haal het apparaat niet uit elkaar! Neem in geval

van storingen contact op met de specialzaak. Deze neemt contact op met het servicecentrum en kan het apparaat indien nodig ter reparatie versturen.

IT



**Questo manuale d'uso va considerato parte integrante dell'apparecchio. Prima di usare l'apparecchio, leggere con attenzione le indicazioni di sicurezza e il manuale d'uso. Conservare il manuale d'uso per poterlo utilizzare di nuovo in un secondo momento. Se si vende o si cede l'apparecchio, consegnare il manuale d'uso ad ogni successivo possessore/utilizzatore del prodotto.**

### **PERICOLO di lesioni!**

Non osservare mai direttamente il sole o un punto in prossimità del sole con questo apparecchio. PERICOLO DI ACCECAMENTO!

Non lasciare mai incustoditi i bambini quando usano l'apparecchio. Tenere i materiali di imballaggio (buste di plastica, elastici, ecc.) lontano dalla portata dei bambini! PERICOLO DI SOFFOCAMENTO!

### **PERICOLO DI INCENDIO!**

Non lasciare mai l'apparecchio, in particolare le lenti, esposto ai raggi diretti del sole! La focalizzazione della luce solare potrebbe innescare incendi.

### **PERICOLO per danni a cose!**

Non smontare l'apparecchio! In caso di difetti all'apparecchio rivolgersi al rivenditore specializzato. Il rivenditore si metterà in contatto con il servizio di assistenza clienti ed eventualmente manderà l'apparecchio in riparazione.

ES



**El presente manual de instrucciones se debe considerar parte integrante del aparato. Antes de utilizar el aparato, lea detenidamente las indicaciones de seguridad y el manual de instrucciones. Guarde el presente manual de instrucciones por si necesita volver a utilizarlo más tarde. En caso de venta o entrega a terceros del aparato, se debe entregar el manual de instrucciones al siguiente propietario/usuario del producto.**

### **¡PELIGRO de lesiones corporales!**

No mire nunca con este aparato directamente hacia el sol o hacia sus inmediaciones. ¡Existe PELIGRO DE CEGUERA!

Los niños sólo deben utilizar el aparato bajo la supervisión de un adulto. ¡Mantener fuera del alcance de los niños los materiales de embalaje

(bolsas de plástico, cintas de goma, etc.)! ¡Existe PELIGRO DE ASFIXIA!

### ¡PELIGRO DE INCENDIO!

¡No exponga el aparato (especialmente las lentes) a la radiación directa del sol! La concentración de luz podría provocar incendios.

### ¡PELIGRO de daños materiales!

¡No desmonte el aparato! En caso de que perciba un defecto, diríjase a su tienda especializada. En ella se pondrán en contacto con el centro de servicio técnico y, si procede, enviarán el aparato para que sea reparado.

PT



**Este manual de instruções deve ser considerado como parte do aparelho.**

**Antes de utilizar o aparelho, leia com atenção as advertências de segurança e o manual de instruções.**

**Guarde este manual de instruções de forma a poder consultá-lo mais tarde.**

**Ao vender ou entregar o aparelho a outro proprietário/utilizador do produto deve entregar juntamente o manual de instruções.**

### RISCO de ferimentos!

Nunca direcione este aparelho directamente para o sol ou para perto do sol. RISCO DE CEGUEIRA!

As crianças só devem utilizar o aparelho sob vigilância. Manter os materiais da embalagem (sacos de plástico, elásticos, etc.) afastados das crianças! RISCO DE ASFIXIA!

### RISCO DE INCÊNDIO!

Não sujeite o aparelho – sobretudo as lentes – à radiação solar directa! A compressão da luz pode provocar um incêndio.

### RISCO de danos materiais!

Não desmonte o aparelho! Em caso de defeito, consulte o seu distribuidor especializado. Ele contactará o Centro de Assistência e poderá enviar o aparelho para uma eventual reparação.

RU



**Данное руководство по эксплуатации является частью устройства.**

**Перед использованием устройства внимательно прочитайте инструкции по технике безопасности и руководство по эксплуатации. Сохраните руководство по эксплуатации**

**для последующего использования.**

**При продаже или передаче устройства руководство по эксплуатации необходимо передать следующему владельцу (пользователю).**

### ОПАСНОСТЬ травмирования!

Ни в коем случае не смотрите через этот прибор прямо на солнце или в направлении солнца. Опасность ПОТЕРИ ЗРЕНИЯ!

Дети должны использовать прибор только под присмотром взрослых. Исключите доступ детей к упаковочным материалам (пластиковые пакеты, резиновые ленты и т.д.)! ОПАСНОСТЬ УДУШЬЯ!

### ОПАСНОСТЬ ПОЖАРА!

Не прибор – в особенности линзы – под прямыми солнечными лучами! Из-за фокусировки солнечных лучей может возникнуть пожар!

### ОПАСНОСТЬ причинения материального ущерба!

Не разбирайте прибор! В случае неисправности обращайтесь к дилеру. Он свяжется с сервисным центром и может переслать прибор для выполнения ремонта.

## I

### Scope of delivery

Fig. 1

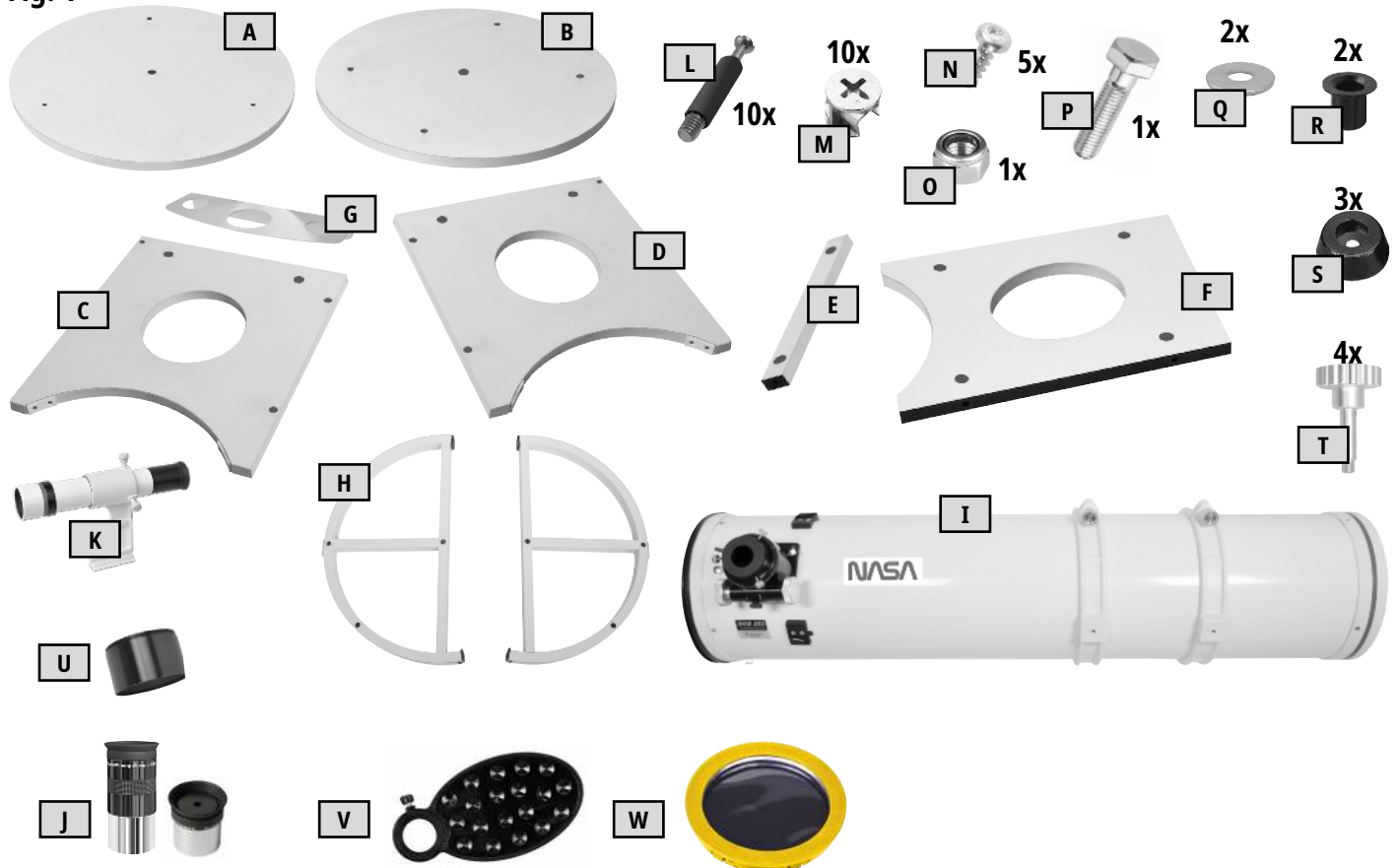

# II

## Parts Overview

Fig. 2

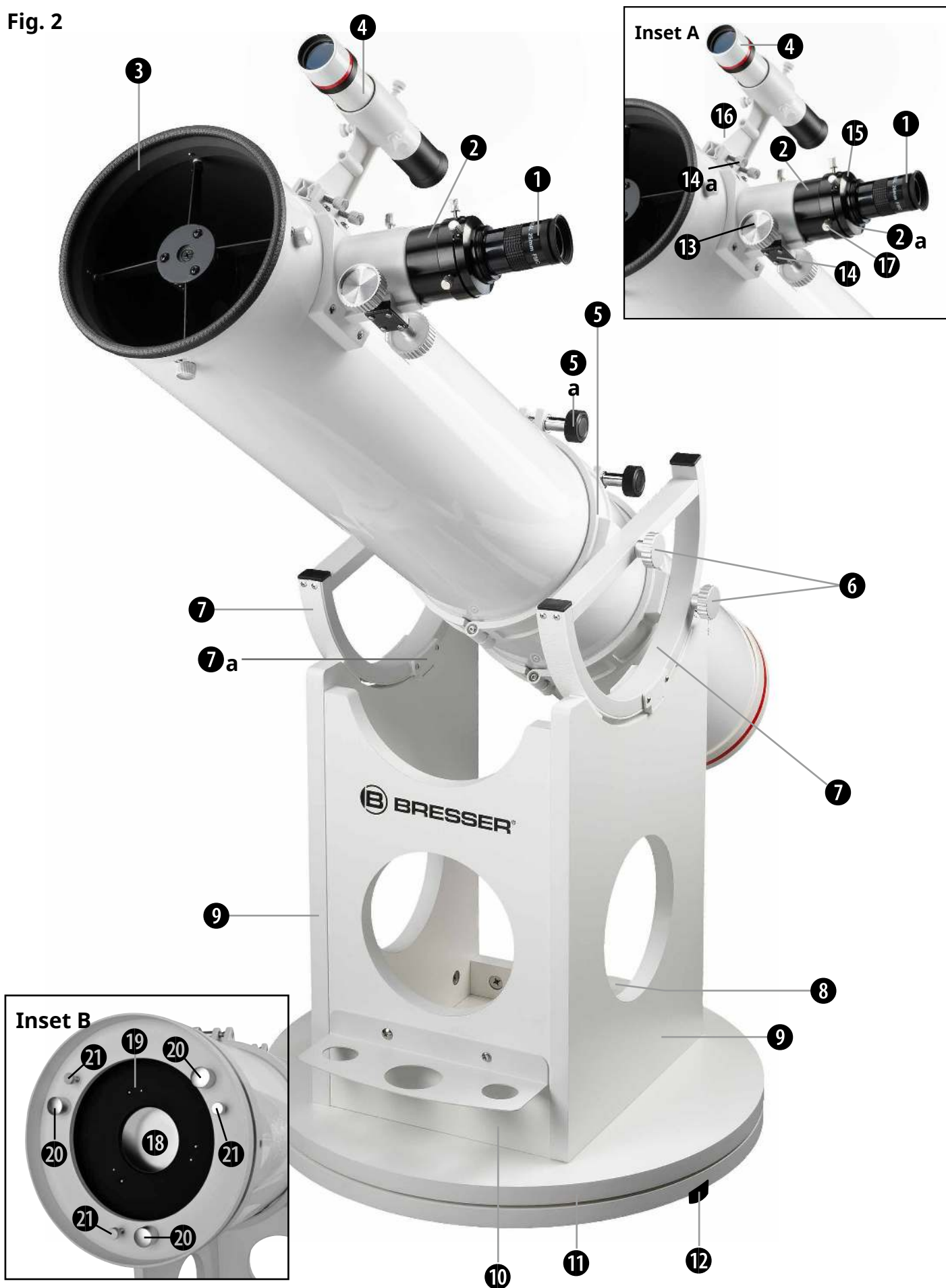

## II

## Parts Overview

### OTA (Optical Tube Assembly) (Fig. 2)

1. Eyepiece
2. Eyepiece extension
- 2a. Eyepiece holder
3. Aperture
4. LED viewfinder
5. OTA bracket (2x) with clamp screw (5a)
6. Fixing screws (4x)
7. Altitude wheels (2x) with lateral guides (7a)

### Basis (Fig. 2)

8. Basis bridge
9. Basis side parts (2x)
10. Basis front part
11. Round basis plate (2x)
12. Rubber feet (3x)

### Eyepiece holder and LED viewfinder (Inset A)

13. Focusing drive
14. Friction screws (Focus lock and grinding pressure adjustment)
- 14a. Fixing screws
15. 1 ¼" and 2" eyepiece holder
17. Clamp screw

### OTA's bottom side/mirror frame (Inset B)

18. Mirror backside
19. Mirror frame
20. Collimation screws (3x)
21. Counter screws (3x)

### Smartphone holder

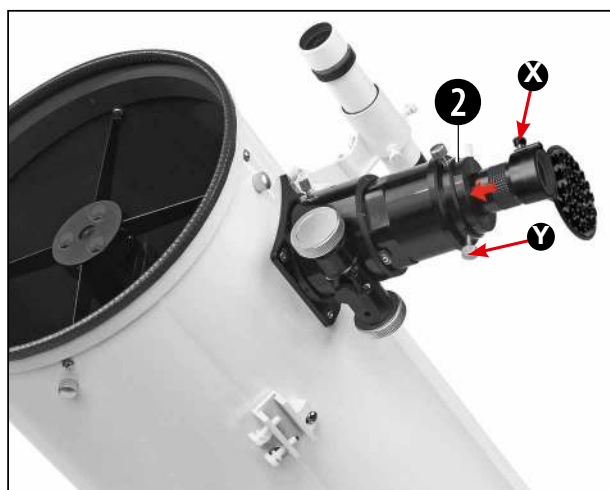

Insert the eyepiece (1) into the smartphone holder and tighten the screw (X) to the bracket firmly. Then set the smartphone holder with the eyepiece into the eyepiece connection (2) and tighten the clamping screws (Y) by hand firmly. Now start your smartphone camera app and press your smartphone on the plate. Make sure that it is properly secured. The camera should rest just above the eyepiece. Place the smartphone exactly over the eyepiece, so that the image is exactly centered on your display. It may be necessary to use the zoom function to fill out the whole screen of your smartphone. The suction cups must be dry, clean and free from all kinds of dust and dirt. We assume no responsibility for dropped and broken smartphones due to incorrect handling.



Full Manual Download:

[www.bresser.de/P9800760](http://www.bresser.de/P9800760)

# III

## Setup

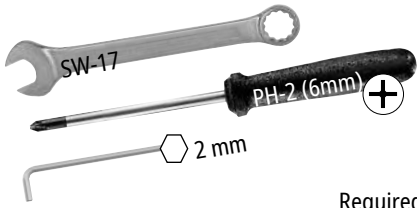

Required

### Assembling the base

#### ! NOTE!

You additionally need a suitable Phillips screwdriver, an Allen wrench and an open-end wrench or ring wrench for assembling. Use an old carpet or another soft surface to avoid any damages to the component parts.

#### ! IMPORTANT!

Note that the studs are height-adjustable. It is therefore not necessary to screw in the studs until they stop.

**Important: Make sure that only approx. 4 mm of the stud heads are visible in the holes for the quick fasteners. So the quick fastener and the stud head will interlock and all parts are firmly connected. For that, install the studs accordingly in height (see Fig. A1).**

Fig. 3

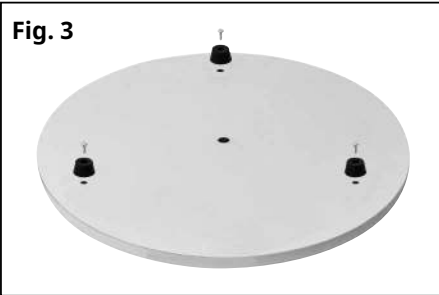

#### STEP 1 (Fig. 3):

The base supports the OTA and allows for a movement in all directions.

1. Put the first bottom plate (Fig. 1, A) on the floor and place the rubber feet (Fig. 1, S) over the outer drill holes.
2. Screw each rubber feet down with a woodscrew (Fig. 1, N).

Fig. 4

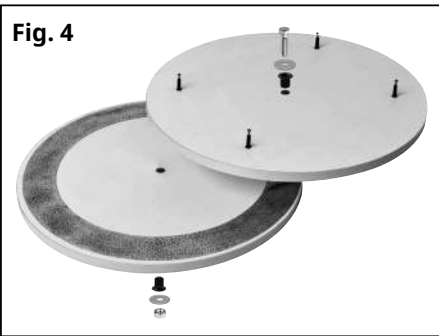

#### STEP 2 (Fig. 4):

1. Insert a plastic sleeve (Fig. 1, R) into the drill hole in the middle of both bottom plates (Fig. 1, A + B).
2. Screw four threaded bolts (Fig. 1, L) into the outer drill holes of bottom plate on top.
3. Put both bottom plates on top of each other.
4. Bolt both bottom plates together with the fine-thread screw (Fig. 1, P) and the safety nut (Fig. 1, O). Place one ring washer (Fig. 1, Q) on each side between the screw head or nut and the plastic sleeve.

#### STEP 3 (Fig. 5):

1. Put all side parts (Fig. 1, C-F) on the floor.
2. Screw the threaded bolts (Fig. 1, L) into the small drill holes of both side parts (Fig. 1, C + D).
3. Insert two quick fasteners (Fig. 1, M) into the large drill holes of both side parts and the bridge (Fig. 1, E) and four quick fasteners into drill holes of the front part (Fig. 1, F).

Fig. 5

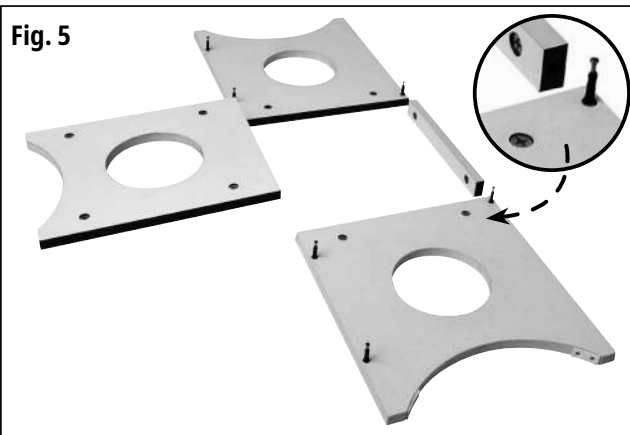

#### ! NOTE!

Make sure that the opening at the bottom of the quick fasteners is pointing to the drill hole on the edge. An arrow at the notch for the Phillips head is showing the right direction.

Fig. 6

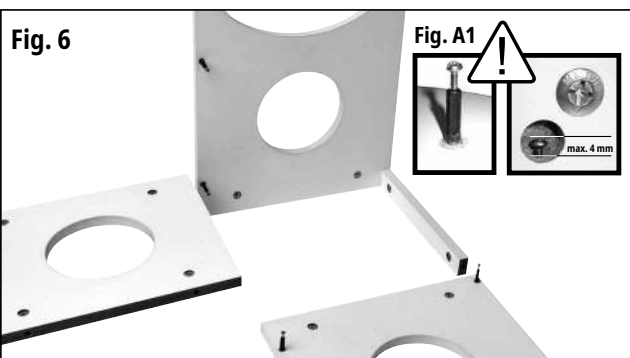

#### STEP 4 (Fig. 6):

1. Set up the left side part (Fig. 1, C) and put the bridge (Fig. 1, E) with its drill holes for the quick fasteners (Fig. 1, M) over the threaded bolts (Fig. 1, L).
2. Tighten the quick fasteners with a Phillips screwdriver.

# III

## Setup

Fig. 7

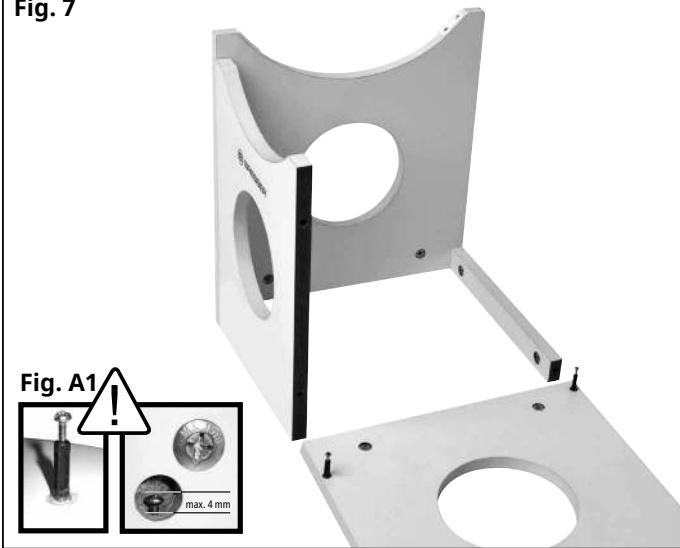

### STEP 5 (Fig. 7):

1. Set up the front part (Fig. 1, F) and put it with the drill holes of the quick fasteners (Fig. 1, M) over the threaded bolts (Fig. 1, L) of the left side part (Fig. 1, C).
2. Tighten the quick fasteners with a Phillips screwdriver.

Fig. 8

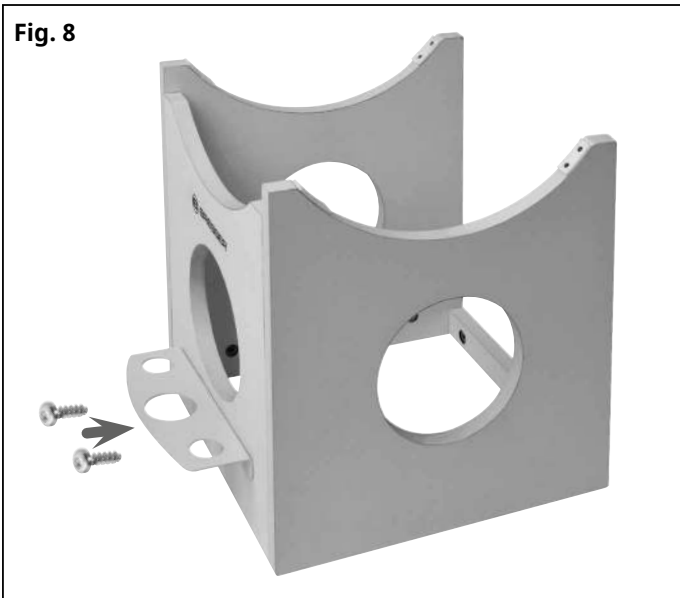

### STEP 6 (Fig. 8):

1. Set up the right side part (Fig. 1, D) and put it with the drill holes of the quick fasteners (Fig. 1, M) over the remaining threaded bolts (Fig. 1, L) of the bridge (Fig. 1, E) and the front part (Fig. 1, F).
2. Tighten the quick fasteners with a Phillips screwdriver.
3. Use two woodscrews (Fig. 1, N) to attach the accessory tray (Fig. 1, G) to the front part.

Fig. 9

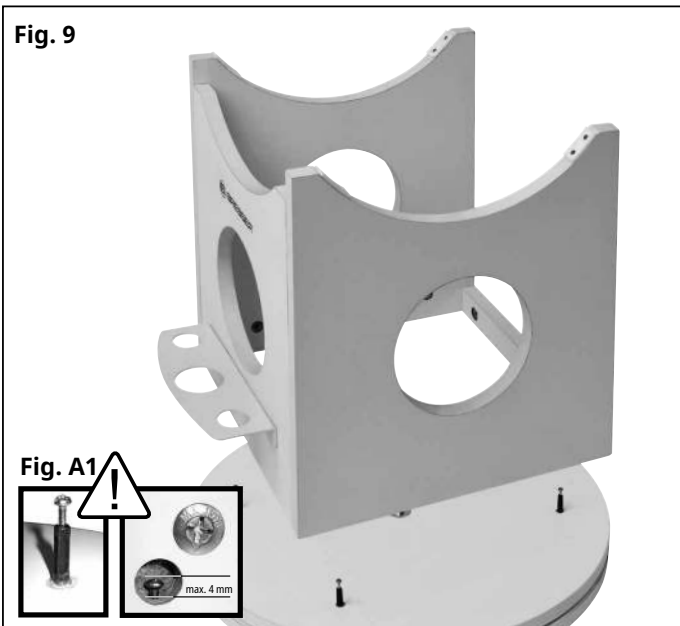

### STEP 7 (Fig. 9):

1. Put the complete base construction with the drill holes of the quick fasteners at the bottom first (Fig. 1, M) over the threaded bolts (Fig. 1, L) of the prepared bottom plate construction.
2. Tighten the quick fasteners (Fig. 1, M) with a Phillips screwdriver.

Fig. 10

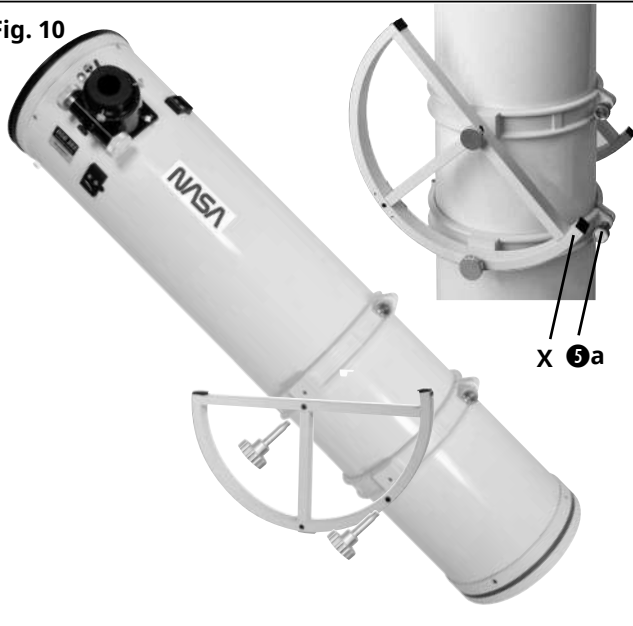

### Attaching the OTA

#### STEP 8 (Fig. 10):

1. Attach both altitude wheels (Fig. 1, H) with the fixing screws (Fig. 1, T) to the right and left side of the OTA.

#### ! NOTE!

Make sure that the 'noses' on one side (Fig. 10, X) are pointing in the direction of the clamp screws (Fig. 10, 5a) for the brackets and that the lateral guides of the altitude wheels are pointing at one another.

Fig. 11

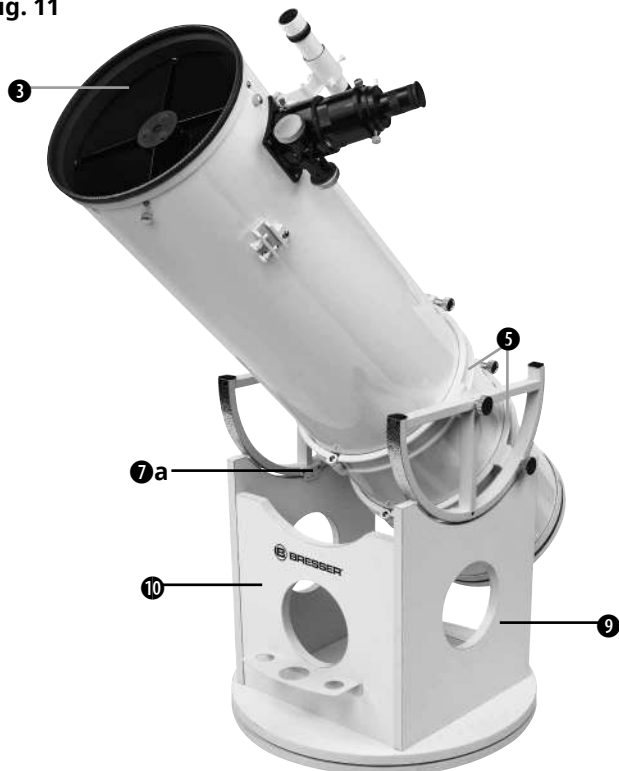

#### STEP 9 (Fig. 11):

1. Put the OTA with the attached altitude wheels into the half round sections of the side parts (Fig. 11, 9).

#### ! NOTE!

Make sure that the aperture of the OTA (Fig. 11, 3) is pointing in the direction of the front part (Fig. 11, 10) when attaching it.

2. Hold the OTA with one hand until it is balanced correctly. If necessary, move the OTA a little to another position within the brackets (Fig. 11, 5) to establish a balance. Also when changing the accessories a new balancing of the OTA is required.

#### ! NOTE!

Balancing is important because otherwise the tube could tip over at a low imbalance and could be damaged.

3. Adjust the lateral guides (Fig. 11, 7a) of the altitude. Use a suitable 2mm Allen wrench. The side floating and the friction of the altitude axis can be adjusted by evenly tightening the four Allen screws (two per lateral guide).

#### ! NOTE!

Do not tighten the screws too firmly to avoid premature wear.

# IV

## Installing accessories

Fig. 12

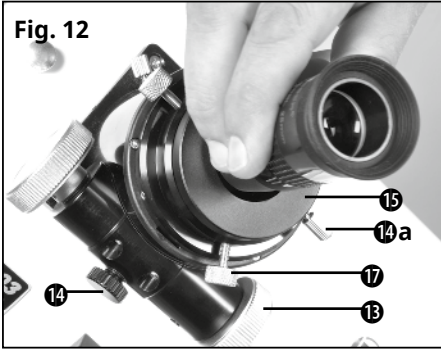

### Inserting the eyepiece (Fig. 12)

1. Insert the 25 mm 1 ¼" eyepiece (Fig. 1, J) into the eyepiece holder (Fig. 12, 15).
2. Tighten the clamp screw (Fig. 12, 17) slightly.
3. Look through the eyepiece and turn the focusing wheel of the focusing drive (Fig. 12, 13) right or left to focus the image.
4. When using a 2" eyepiece remove the 1 ¼" eyepiece adapter (Fig. 12, 15) from the holder first.
5. Now insert the 2" eyepiece and fix it with the lock screw.

The eyepiece holder is equipped with a friction screw (Fig. 12, 14) on its bottom side and with two fixing screws (Fig. 12, 14a) on its top side. Adjust the friction screw so that the focusing drive can be moved sensitively. Additionally the focuser can be fixed with the fixing screws to avoid unintentional adjustment.

#### ! NOTE!

Loosen the fixing screws on the focuser completely before start focusing! Never tighten the friction screw and fixing screws too firmly.

Fig. 12a

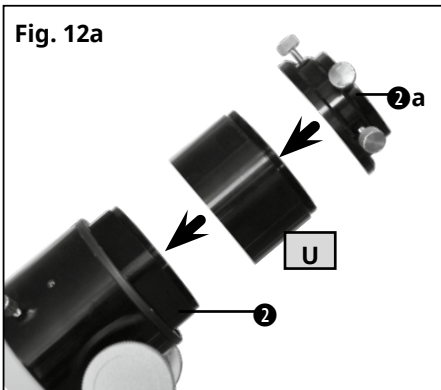

### Attaching a spacer sleeve (Fig. 12a)

#### ! NOTE!

A spacer sleeve resolves focusing problems when the focusing point is not close to the eyepiece extension. With a spacer sleeve it is for example possible to use the telescope for photography or to use eyepieces with the telescope that offer an extrem focal position. Thereby it is bridging the optical distance by its own length. When using a spacer sleeve, it is also no longer necessary to turn out the eyepiece extension until it stops. Furthermore it will increase the mechanical stability.

1. Unscrew the eyepiece holder (Fig. 12, 2a) and remove it from the eyepiece extension (Fig. 12, 2).
2. Screw the spacer sleeve (Fig. 12, U) on the eyepiece extension (Fig. 12, 2).
3. Screw the eyepiece holder (Fig. 12, 2a) on the spacer sleeve (Fig. 12, U).
4. By screwing two or more optional spacer sleeves together, the optical distance can be extended additionally.

Fig. 13

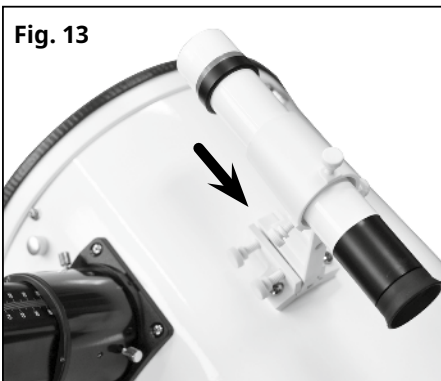

### Attaching the viewfinder holder (Fig. 13)

Slide the viewfinder holder into the slit of the pre-installed holder base. Fix holder base by tightening the fixing screws.

### Attaching the viewfinder

Remove the viewfinder's adjustment screws and slide the viewfinder into the holder. The objective lens of the viewfinder must face to the sky.

Tighten the viewfinder's adjustment screws by hand. Read more under 'Align the viewfinder'. Remove the dust protection cap before using it.

Fig. 14

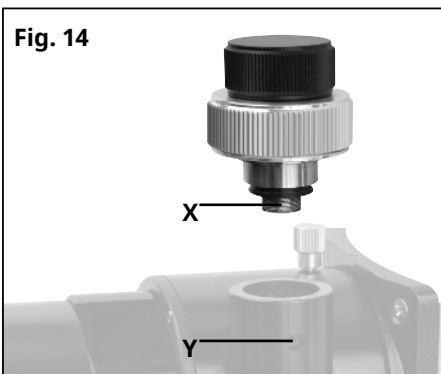

### Attaching the 10:1 Micro reduction (optional) (Fig. 14)

The 10:1 Micro reduction unit (Art. No. 06-25720) is available as an optional accessory and can be attached instead of the normal reduction. It allows for normal focusing speed as well as for a focusing speed that is reduced by ten times and therefore provides a very fine focusing.

1. Loosen the Allen screw at the bottom side of the right focusing wheel with an Allen wrench.
2. Pull out the focusing wheel.
3. Insert the 10:1 micro reduction unit and tighten the Allen screws of the drive shaft (Fig. 14, X) and the Allen screw of the housing (Fig. 14, Y) sturdy.

## Using a Dobsonian telescope

1. Never lubricate the Teflon pads on the ground plate. Your Dobsonian has been designed with some inherent friction. You want the telescope to move easily when you position it, but you also want it to stay in the position you place it. Using any kind of oil, silicone spray, wax, or grease will ruin the performance by causing the telescope to move too easily. Just keep these bearing surfaces clean; that's all the maintenance required.
2. The altitude bearing surfaces (Fig. 1, 7) of the telescope are lightly lubricated at the factory for optimum performance. Over a period of time, these surfaces may become dry or dirty. Simply clean off the bearing surfaces with a dry cloth or paper towel. Do not use solvents or alcohol-based cleaning solutions as this may damage the bearings or the painted surfaces of the telescope.
3. You will notice that your telescope will move in altitude by raising and lowering the tube, and in azimuth by rotating the base. As you observe objects in the night sky they will appear to drift out of the field of view due to the Earth's rotation. To keep an object centered in the field of view, just lightly nudge the telescope in the proper direction. This may take a little practice at first, but you'll soon get the hang of it.
4. Be sure the Mount is placed on a relatively level surface to allow proper operation. Each of the three feet should be in firm contact and not wobble. If you are in an area with particularly rough or soft ground, it may be helpful to place the mount on a thick piece of plywood.
5. Part of the fun of using a Dobsonian type of telescope is the challenge of hunting for objects in the night sky. Invest in some simple star charts and books that tell you how to locate objects using a technique called "star hopping." Once you begin learning the star patterns and constellations, you're well on your way to finding many amazing sights.

Fig. 15



### Align the Viewfinder (Fig. 15)

The wide viewfinder's field of view offers an easier way to observe objects than an eyepiece which provides a smaller field of view. If you have not already attached the viewfinder to the telescope, follow the procedure described before.

For an sensible use of the viewfinder, it must be aligned with the telescope so that both the viewfinder and optical tube point at the same position in the sky. This alignment makes it easier to find objects: First locate an object in the wide-field viewfinder, then look through the telescope's eyepiece for a detailed view.

To align the viewfinder, perform steps 1 to 4 during the daytime; step 5 should be performed at night.

1. Remove the dust covers from the telescope and from the viewfinder.
2. If you have not already done this, insert the included eyepiece into the eyepiece holder of telescope.
3. Look through the viewfinder at an object at a distance of at least 1000m. If the distant object is not in focus, turn the focus lock ring of the viewfinder counterclockwise to loosen the front cell. Twist the front cell until the observed image is in focus and retighten the focus lock ring.
4. Point the telescope at a tall, well defined and stationary land object (e.g. a tree or an antenna) at a distance of at least 1000m and center the object in the eyepiece. Bring the image in focus by turning the focus knob.
5. Look through the viewfinder. Loosen or tighten one or more of the viewfinder's adjustment screws to align the viewfinder. Make sure that the viewfinder's crosshairs are precisely centered on the object that had been centered in the telescope's eyepiece before. After done this, the telescope is ready for the first observation.

#### Attention!

NEVER look through the telescope at or near the sun! Looking at the sun will cause irreversible damages to your eyes - even when observing for just a fraction of a second. Furthermore it will also cause damages to the telescope.

6. Repeat the alignment procedure for an object at the night sky (e.g. a bright star or the moon) and make the necessary fine adjustments. Therefore, follow steps 3 and 4 above. With this alignment, the objects which were visible in the viewfinder's wide field of view will also be visible when looking through the telescope.

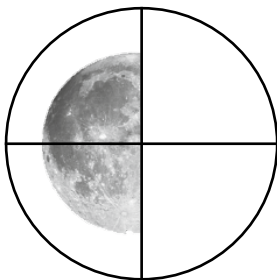

## Calculating the magnification

The magnification, or power of a telescope is determined by two factors: the focal length of the eyepiece and the focal length of the telescope.

Your telescope is supplied with two eyepieces. The focal length of the eyepiece, 25mm / 5 mm, is printed on its side.

The focal length of the 6" Dobsonian is 1200 mm.

To change magnification, change eyepieces.

To calculate the magnification of a given eyepiece, use this formula:

$$\text{Magnification} = \frac{\text{Telescope focal length}}{\text{Eyepiece focal length}}$$

Example with the 6" Dobsonian and a 25 mm eyepiece:

$$\text{Magnification} = \frac{1200 \text{ mm}}{25 \text{ mm}} = 48x \text{ (approx. value)}$$

Beispiel mit dem 6" Dobson und einem 5 mm Okular:

$$\text{Magnification} = \frac{1200 \text{ mm}}{5 \text{ mm}} = 240x \text{ (approx. value)}$$

The type of eyepiece, whether Modified Achromatic, Plössl, or Super Plössl, has no effect on magnification, but does have a bearing on such optical characteristics as field of view, flatness of field, and color correction.

Maximum practical magnification is about 50X per inch of aperture (for the 6" it is: 150 mm x 2 = approx. 300X magnification). Generally, however, lower powers produce higher image resolution. When unsteady air conditions prevail (as witnessed by rapid "twinkling" of the stars), extremely high powers result in distorted magnification and observational details are diminished by the use of excessive power.

When beginning observations on a particular object, always start with a low power eyepiece. Centered the object in the field of view. Sharply focus the object. Then try using a higher power eyepiece. If the image starts to become fuzzy when you use higher magnification, back down to a lower power. The atmosphere is not sufficiently steady to support high powers. Keep in mind that a bright, clearly resolved, but smaller image will show far more detail than a dimmer, poorly resolved larger image.

## Observation

Allow for a temperature adjustment for about 90 minutes before starting an observation. Because when bringing the telescope e.g. from a heated car or house to a place outside so called tube seeing may occur. This means that the primary mirror is warmer than the air and will produce air turbulence. After the temperature adjustment the telescope will produce a sharp image.

Try out your telescope during the daytime at first. It is easier to learn how it operates and how to observe when it is light.

Pick out an easy object to observe: A distant mountain, a lighthouse or something else. Point the optical tube so it lines up with the object.

Look through the LED viewfinder until you can see the object.

Once you have the object lined up in the finder, it should also be visible in the optical tube's 25 mm eyepiece.

Look through the eyepiece and start focusing on the object you have chosen.

When you feel comfortable with the finder, the eyepieces, the locks and the adjustment controls, you will be ready to try out the telescope at night. The Moon is the best object to observe the first time you go out at night. Pick a night when the Moon is a crescent. No shadows are seen during a full Moon, making it appear flat and uninteresting.

Use a neutral density filter (sometimes called a "moon filter") when observing the Moon. Neutral density filters are available from your local dealer as an optional accessory.

Spend several nights observing the Moon. Some nights, the Moon is so bright that it makes other objects in the sky difficult to see. These are nights that are excellent for lunar observation. The most obvious features are craters. The dark areas on the Moon are called maria and are composed of lava from the period when the Moon still had volcanic activity. You can also see mountain ranges and fault lines on the Moon.



Fig. 16: Craters of the moon are excellent targets to observe even for beginners.



Fig. 17: Planet Venus in its thin crescent phase



Fig. 18: Jupiter's four largest moons can be observed in a different position every night.

### Planets

During their orbit around the sun the planets are continuously changing their position on the sky. You can find the actual position of the planets in astronomy circulars and soon on the information center of the Explore Scientific homepage. The following planets are especially suited for observations with your telescope:

#### Venus

The diameter of Venus is about 9/10 the diameter of the Earth. When Venus is orbiting the sun the astronomer can observe the change of the light phases of Venus during this orbit: Crescent, half Venus, full Venus – very much like the phases of the moon. The planetary disc of Venus appears white because the sunlight is reflected by a compact layer of clouds that covers all surface details. Venus is only visible before dawn and shortly after dusk in the vicinity of the sun, so be careful not to look into the sun.

#### Mars

The diameter of Mars is about half the Earth's diameter. In a telescope Mars appears as a tiny red-orange disk. Maybe you will see a tiny white patch when you look at the polar regions that are covered in ice. About every two years, when Mars and Earth reach their smallest distance you can discover new features.

#### Jupiter

The biggest planet in our solar system is Jupiter with about 11 times bigger equatorial diameter than the Earth. The Planet appears as a disk that is covered in dark lines. Those lines are cloud bands in the atmosphere of Jupiter. Even with low magnification 4 of the 67 moons of Jupiter are visible – the so called Galilean moons (Io, Ganymed, Europa and Callisto). Because those moons are orbiting Jupiter the visible number and position changes. Sometimes a moon passes above the planetary disc of Jupiter – then the shadow of the moon can be spotted on the planet as a sharp dark spot.

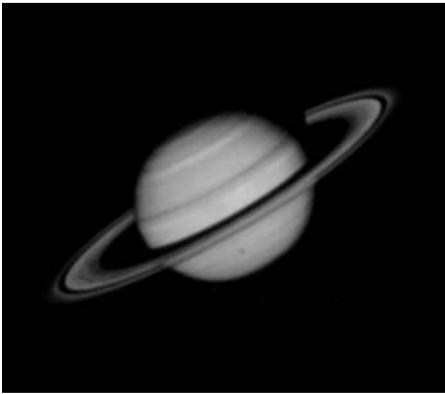

Fig. 19: Saturn is perhaps the most unforgettable sight to see in a telescope.

### Saturn

Saturn has a diameter about 9 times the Earth's diameter and appears as small roundish disc. You can see the rings of Saturn on both sides of the planetary disc. Galilei, who was the first human observer of this planet in 1610 couldn't know that the planet had rings – he described that Saturn had „ears“. The rings of Saturn mainly consist of billions of icy particles – from tiniest dust up to the size of a house. The biggest division in the rings, the so called „Cassini division“ should be easily seen with your telescope in nights of steady air. The biggest of the 62 moons of Saturn, Titan, is also visible as a bright, starlike object in the vicinity of the planet. Up to 6 moons can be detected in your telescope.

### Deep-Sky-Objekte

To locate constellations, stars or „deep-sky-objects“, it makes sense to use a star chart. We will list a selection of deep sky objects here:

Stars are giant objects that mainly consist of gas. Due to the nuclear fusion in their core they radiate energy and shine. The stars are extremely far away. Because of this vast distance they appear as tiny spots of light in your telescope, despite their size – no matter how big your telescope is.

Nebulae are giant interstellar clouds of gas and dust. Within those clouds new stars are born. The premier nebula on the northern hemisphere is the Great Orion Nebula, a diffuse nebula that looks like a fuzzy patch of light. M42 is 1600 light years away from Earth.

An open cluster is a group of young stars that were born in a single diffuse nebula not too long ago (on an astronomical time scale...). The Plejades are an open cluster in a distance of about 410 light years. You can see several hundred stars in the telescope.

Constellations are big patterns of stars that were believed to be celestial representations of men, gods and objects by the old civilizations. Those patterns are too big to be observed at a single glance through a telescope. If you want to become familiar with the constellations, start with a pattern that is easy to find, like the Big Dipper in the constellation Ursa Major. Try to locate the other constellations in the neighborhood of this constellation in the second step and move on to even more distant patterns.



Fig. 20: M31, the Andromeda galaxy, is one of the easiest galaxies to locate and observe during the fall and winter evenings.

Galaxies are gigantic accumulations of stars, nebulae and clusters that are held together by gravity. Most galaxies have a spiral shape (like for example our own galaxy, the Milky Way), but there are also galaxies with elliptical or irregular shapes. The closest spiral galaxy is the Andromeda Galaxy (M31). The core of M31 looks like a bright patch of light in your telescope – under dark clear skies you will be able to detect features in this object with your telescope.

When you become an advanced observer you can look for other types of objects such as asteroids, planetary nebula and globular clusters. And if you're lucky, every so often a bright comet appears in the sky, presenting an unforgettable sight.

The more you learn about objects in the sky, the more you will learn to appreciate the sights you see in your telescope. Start a notebook and write down the observations you make each night. Note the time and the date.

One of the best methods to record your telescopic views is astronomical sketching. It improves your ability to see fine detail and subtle variations in brightness.

Many astronomical magazines and online forms give the opportunity to get in contact with other amateur astronomers.

Online resources like [www.cloudynights.com](http://www.cloudynights.com) or [www.stargazerslounge.com](http://www.stargazerslounge.com) help to build up knowledge and get to know other aspects of the hobby. The more you know about it, the more fun this hobby will be!



Fig. 21: The Pleiades is probably the most striking star cluster to observe in the Northern Hemisphere.

## Useful tips

By the way, you might have noticed something strange when you looked through your eyepiece. The image is upside down, and it is also reversed. That means reading words can be a problem or viewing objects on the ground can be a problem. But it has no effect on astronomical objects.

Because of the Earth's rotation all objects seem to drift across the field of view. To compensate this movement you have to move the telescope smoothly and slowly. The higher the magnification the more accurate this tracking movement has to be.

Another solution is to place the object on the eastern rim of the field of view and let it drift across the field, then reposition it on the eastern rim again. However – this method only works with good eyepieces that are delivering a sharp image up to the edge of the field.

**Vibrations:** Try to avoid touching the eyepiece during observations. Touching the eyepiece and the slight shiver of the hand will cause unsteady views.

**Dark adaption:** Give your eyes some time to adapt to the darkness. This takes about 20-30 minutes after an exposure to a bright light – even if it is a short exposure. Use a dim light with a red filter to read star charts or draw objects – dim red light does not influence the dark adaption very much.

**Observations through a window are very disadvantageous (even if the window is open). The light that is gathered by the telescope has to pass a lot of air and glass layers, causing severe image deterioration.**

**Planets and other objects** that are close to the horizon are severely influenced by air turbulence and absorbance. It is much better to time your observations in a way that those objects are close to the meridian, so that they are on their highest position possible. If the image is dim or moving fast, use a smaller magnification. Using too much magnification is a mistake that is made very often by beginners.

**Warm clothing:** Even in the summer the nights may get very cold during clear nights, especially on the mountains. Always remember to bring warm clothing like thick jackets, beanies, gloves, winter shoes and thick socks – even if you were sweating during the day. It is hard to enjoy even the best night when you are freezing!

**Explore your observing site during the day:** The ideal site should be far of frequently used streets and other light sources that would prevent your eyes to become dark adapted. Keep in mind that it is likely to get foggy in the vicinity of open water, such as river valleys or lakes. The ground should be solid and relatively flat. You can observe in the city, but try to get to a place some distance away, where you can see the milky way if possible. You can get really good conditions as close as 50 km outside of cities. An old astronomer's quote says: "you cannot really replace a dark sky by anything than a darker sky"

### **Additional information:**

As mentioned before, a lot of additional information for people of all ages can be found in the internet and in specialist magazines. Most public libraries normally offer good literature. You may also contact an astronomical organisation next to you. Events are often announced in the local press.

## Maintenance

Your telescope is a precision instrument that will provide many years of fun. When you are treating this telescope with the same care as for example a expensive camera, it is very unlikely that you will ever need to return it for service or maintenance. Please notice the following rules:

1. Avoid cleaning the optics. A little dust on the optical system will not deteriorate the performance of the optical system by any noticeable amount. A little dust should not be a reason to clean the optics.
2. If cleaning the optics is necessary it is best to brush away the dust with a fine camel hair brush as it is used for photographic equipment. NEVER USE pressurized air or microfiber cloth as it is often recommended for glasses.
3. Organic dirt (fingerprints etc.) can be removed from the optical surface with a mixture of 3 parts distilled water and one part isopropanol. You may add a very little bit of glass cleaner to the mix. Only use soft, white cosmetic tissues. Soak the mirror to dissolve the dirt and remove the fluid with short, cautious strokes. Remember to change tissues every few strokes.

Attention: Never not use any pre-impregnated cleaning cloths!

4. While you are using your telescope during the night you will eventually have dew condensing on the surfaces. This will not cause any trouble – your telescope is designed to take a little moisture without problems. When you store the telescope, however, we recommend to wipe the surfaces (except the optics) with a dry cloth and give the telescope some time to evaporate the water on the optics by putting the telescope into a dry room with the lid of the mirror box open. Wait until all water has dried off until you store the telescope.
5. If your telescope is not to be used for an extended period, perhaps for one month or more, it is advisable to remove the batteries from the battery pack. Batteries left in the telescope for prolonged periods may leak, causing damage.
6. Do not leave your telescope inside a sealed car on a warm summer day; excessive ambient temperatures can damage the telescope's internal lubrication.

## Collimation

All telescopes are collimated precisely at the factory before shipment. However – a telescope that was disassembled has to be freshly collimated after reassembly. Collimating a telescope is a straightforward procedure that is not very difficult. The collimation procedure is slightly different

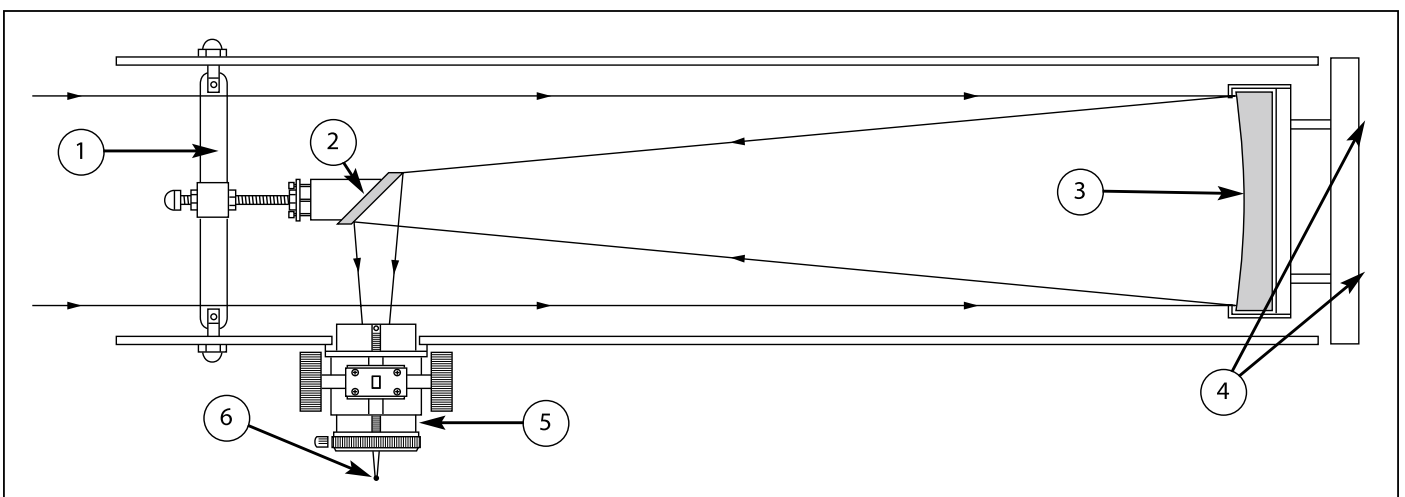

Fig. 21: Newtonian reflecting telescope. Spider vanes (1); secondary mirror (2); parabolic primary mirror (3); primary mirror adjustment screws (4); focuser drawtube (5); focused image (6).

from that of other Newtonian reflecting telescopes, because of the "fast"  $f/5$  to  $f/6$  focal ratio of the primary mirror. In typical Newtonian reflectors with more conventional focal ratios (i.e. longer focal ratios), when the observer looks down the focuser tube (without an eyepiece in the focuser), the images of the diagonal mirror, primary mirror, focuser tube and the observer's eye appear centered relative to each other.

However, with the short focal ratio primary mirror of this Dobsonian telescope, correct collimation requires that the diagonal mirror be offset in 2 directions: (1) away from the focuser and (2) towards the primary mirror, in equal amounts. This offset is approximately  $1/8"$  in each direction. Note that

# VI

## Maintenance and Cleaning

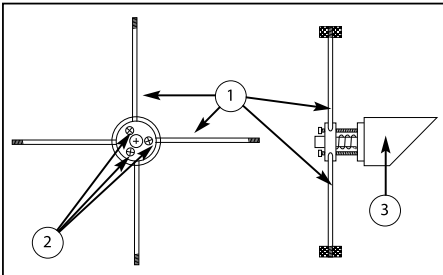

Fig. 22: Secondary Mirror Assembly (front and side view). Spider vanes (1); tilt screws (2); secondary mirror holder (3).

these offsets have been performed at the factory prior to shipment of your telescope. It is only necessary for you to confirm that the telescope has not been badly jarred out of collimation, and to perform the final fine-tuning of Step 4, below. To check and, if necessary, set the optical collimation, follow these steps:

1. Observe through the focuser and orient your body so that the telescope's primary mirror is to your right, and the open end of the telescope tube is to your left. The diagonal mirror will appear centered and round as shown (Fig. 24). If the diagonal appears off center, then adjust the 3 collimation screws on the plastic diagonal mirror housing.
2. If the reflection of the primary mirror (Fig. 24) is not centered on the surface of the diagonal mirror, adjust the 3 collimation adjustment screws on the diagonal mirror housing to center the reflection. As described above, the 3 collimation screws (Fig. 22, 2) on the diagonal mirror housing are used for two different adjustments during the collimation procedure.

### ! NOTE!

**Do not force the 3 screws (Fig. 22, 2) past their normal travel.**

Do not rotate the collimation screws more than two full turns in a counterclockwise direction (i.e. not more than two full turns in their "loosening" direction), or else the diagonal mirror may become loosened from its support. Note that the diagonal mirror collimation adjustments are very sensitive: generally turning a collimation screw 1/2-turn will have a dramatic effect on collimation.

3. If the reflection of the diagonal mirror is not centered within the reflection of the primary mirror, adjust the 3 collimation adjustment screws located on the rear of the primary mirror cell.

### ! NOTE!

The primary mirror housing (Fig. 23) is equipped with 6 screws. The 3 large knurled screws are collimation screws (Fig. 23, 21) and the 3 smaller knurled screws are lock screws (Fig. 23, 20). These lock screws must be loosened before the collimation screws can be turned. Proceed by "trial and error" until you develop a feel for which collimation screw to turn in order to change the image in any given way.

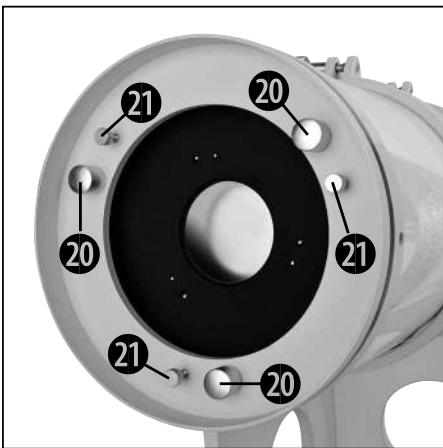

Fig. 23: Underside of rear mirror tube (primary mirror housing). Collimation screws (20); Lock screws (21).

4. Perform an actual star test to confirm the accuracy of steps 1 through 3. Using the 25mm eyepiece, point the telescope at a moderately bright (second or third magnitude) star, and center the image in the main telescope's field of view.
5. Bring the star's image slowly in and out of focus until you see several disks surrounding the star's center. If steps 1 through 3 were done correctly, you will see concentric (centered with respect to each other) circles (Fig. 25, 1). An improperly collimated instrument will reveal oblong or elongated circles (Fig. 25, 2). Adjust the 3 collimating screws on the primary mirror housing until the circles are concentric on either side of the focus.

In summary, the adjustment screws on the plastic diagonal mirror housing change the tilt of the secondary mirror so that it is correctly centered in the focuser drawtube, and so that the primary mirror appears centered when looking into the focuser. The 3 collimating knobs on the primary mirror change the tilt of the primary mirror so that it reflects the light directly up the center of the drawtube.

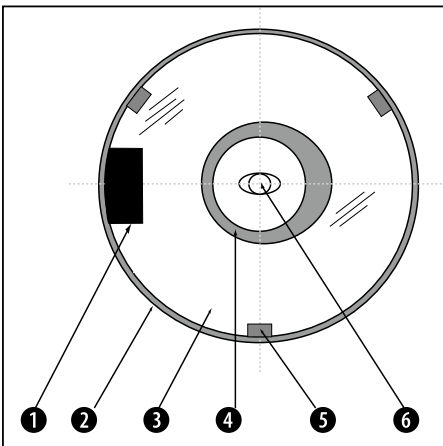

Fig. 24: View you see while collimating the telescope (without eyepiece inserted). Focuser drawtube (1); diagonal mirror (2); reflection of primary mirror (3); reflection of secondary mirror (darkened due to back lighting) (4); primary mirror holder (5); reflection of observer's eye (6)

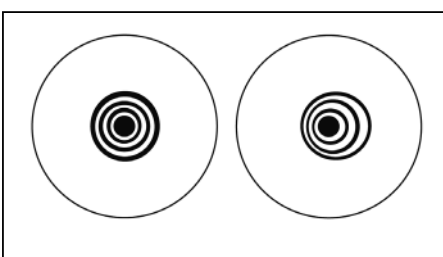

Fig. 25: Correct (1) and incorrect (2) collimation as viewed during a star test.

# VII

## Technical data

<b>Dobson</b>	<b>DOB-150 150/1200 (6")</b> 9800760
Tube (OTA)	Tube made of metal with adjustable brackets and altitude wheels made of aluminium
Secondary mirror holder	four armed, steel
Main mirror diameter/ focal length	6" (150/1200mm),
Aperture ration	f/8
Theoretical resolving power	0,86 arc seconds
Limiting magnitudes	12,7 mag
Focuser	2.0 inch Rack and pinion focuser with 2" and 1¼" adapter
Mount	Dobson system
Accessory tray	For one 2" and two 1¼" eyepieces, installed to the front side
Eyepiece	BRESSER Super-Plössl 25mm (1¼") BRESSER Plössl 5mm (1¼")
Viewfinder	6x30 viewfinder
Weight (OTA)	8.3 kg
Weight (Basis)	7.8 kg
Total weight	16.2 kg

# VIII

## Optional accessories



**BRESSER Messier  
10:1 Micro reduction unit  
with HEXAFOC focuser**

Art. No. 0625720



**EXPLORE SCIENTIFIC  
8X50 FINDER SCOPE**

Art. No. 0620150



**BRESSER MESSIER  
8X50 FINDER SCOPE**

Art. No. 4900850



**EXPLORE SCIENTIFIC  
8X50 FINDER SCOPE 90°**

Art. No. 0620160

Find more additional accessories  
under

[www.bresser.de](http://www.bresser.de)

# IX

## Entsorgung · Disposal · Elimination · Afval · Saltimento · Eliminación · Eliminação Утилизация

DE

 Entsorgen Sie die Verpackungsmaterialien sortenrein. Beachten Sie bei der Entsorgung des Geräts die aktuellen gesetzlichen Bestimmungen! Informationen zur fachgerechten Entsorgung erhalten Sie bei den kommunalen Entsorgungsdienstleistern oder dem Umweltamt.

GB

 Dispose of the packaging materials properly, according to their type, such as paper or cardboard. Please take the current legal regulations into account when disposing of your device. You can get more information on the proper disposal from your local waste-disposal service or environmental authority.

FR

 Éliminez l'emballage en triant les matériaux. Lors de l'élimination de l'appareil, veuillez respecter les lois applicables en la matière. Pour plus d'informations concernant l'élimination des déchets dans le respect des lois et réglementations applicables, veuillez vous adresser aux services communaux en charge de la gestion des déchets.

NL

 Scheid het verpakkingsmateriaal voordat u het weggooit. Let bij het weggooien van een apparaat altijd op de huidige wet- en regelgeving. Informatie over het correct scheiden en weggooien van afval kunt u bij uw gemeentelijke milieudienst inwinnen.

IT

 Smaltire i materiali di imballaggio in maniera differenziata. Per lo smaltimento dell'apparecchio osservare le disposizioni di legge attuali. Le informazioni su uno smaltimento conforme sono disponibili presso il servizio di smaltimento comunale o l'Agenzia per l'ambiente locale.

ES

 Elimine los materiales de embalaje separados por tipos. Por favor, tenga en cuenta las disposiciones legales vigentes a la hora de eliminar el aparato. Obtendrá información sobre la eliminación reglamentaria en los proveedores de servicios de eliminación municipales o en la agencia de protección medioambiental.

PT

 Separe os materiais da embalagem. Na reciclagem do aparelho respeite os regulamentos legais em vigor. Pode obter mais informações sobre a reciclagem correta nos serviços municipais ou na agência do meio ambiente.

RU

 Утилизируйте упаковку как предписано законом. Элементы питания не являются бытовыми отходами, поэтому в соответствии с законодательными требованиями их необходимо сдавать в пункты приема использованных элементов питания. Вы можете бесплатно сдать использованные элементы питания в нашем магазине или рядом с вами (например, в торговых точках или в пунктах приема).

# X

## Garantie & Service · Warranty and Service · Garantie et Service · Garanzia e assistenza Garantía y servicio · Garantia e Serviço · Гарантия и обслуживание

DE

Die reguläre Garantiezeit beträgt 10 Jahre und beginnt am Tag des Kaufs. Die vollständigen Garantiebedingungen sowie Informationen zu Garantiezeitverlängerung und Serviceleistungen können Sie unter [www.bresser.de/garantiebedingungen](http://www.bresser.de/garantiebedingungen) einsehen.

GB

The regular guarantee period is 10 years and begins on the day of purchase. You can consult the full guarantee terms as well as information on extending the guarantee period and details of our services at [www.bresser.de/warranty\\_terms](http://www.bresser.de/warranty_terms).

FR

La durée normale de la garantie est de 10 ans à compter du jour de l'achat. Vous pouvez consulter l'intégralité des conditions de garantie ainsi que les informations concernant la prolongation de la garantie et les prestations de service sur [www.bresser.de/warranty\\_terms](http://www.bresser.de/warranty_terms).

NL

De reguliere garantietermijn bedraagt 10 jaar en begint op de dag van aankoop. De volledige garantievoorwaarden en informatie over de verlenging van de garantietermijn en servicediensten kunt u bekijken op [www.bresser.de/warranty\\_terms](http://www.bresser.de/warranty_terms).

IT

La durata regolare della garanzia è di 10 anni e decorre dalla data dell'acquisto. Le condizioni complete di garanzia e le informazioni sull'estensione di garanzia e i servizi di assistenza sono visibili al sito [www.bresser.de/warranty\\_terms](http://www.bresser.de/warranty_terms).

ES

El período regular de garantía es 10 años iniciándose en el día de la compra. Las condiciones de garantía completas así como informaciones relativas a la ampliación de la garantía y los servicios pueden encontrarse en [www.bresser.de/warranty\\_terms](http://www.bresser.de/warranty_terms)

PT

O prazo de garantia normal perfaz 10 anos e começa no dia da compra. Todas as condições de garantia bem como informações sobre o prolongamento da garantia e prestações de serviço podem ser consultadas em [www.bresser.de/warranty\\_terms](http://www.bresser.de/warranty_terms).

RU

Стандартный гарантийный срок составляет 10 года, начиная со дня покупки. Подробные условия гарантии, информацию о расширенной гарантии и о наших сервисных центрах можно получить на нашем сайте [www.bresser.de/warranty\\_terms](http://www.bresser.de/warranty_terms).

**DE AT CH BE**

Bei Fragen zum Produkt und eventuellen Reklamationen nehmen Sie bitte zunächst mit dem Service-Center Kontakt auf, vorzugsweise per E-Mail.

E-Mail: [service@bresser.de](mailto:service@bresser.de)  
Telefon\*: +49 28 72 80 74 210

**BRESSER GmbH**

Kundenservice  
Gutenbergstr. 2  
46414 Rhede  
Deutschland

\*Lokale Rufnummer in Deutschland (Die Höhe der Gebühren je Telefonat ist abhängig vom Tarif Ihres Telefonanbieters); Anrufe aus dem Ausland sind mit höheren Kosten verbunden.

**GB IE**

Please contact the service centre first for any questions regarding the product or claims, preferably by e-mail.

E-Mail: [service@bresseruk.com](mailto:service@bresseruk.com)  
Telephone\*: +44 1342 837 098

**BRESSER UK Ltd.**

Suite G3, Eden House  
Enterprise Way  
Edenbridge, Kent TN8 6HF  
United Kingdom

\*Number charged at local rates in the UK (the amount you will be charged per phone call will depend on the tariff of your phone provider); calls from abroad will involve higher costs.



**Bresser GmbH**  
Gutenbergstraße 2  
46414 Rhede · Germany  
[www.bresser.de](http://www.bresser.de)

   @BresserEurope

**Bresser UK Ltd.**  
Suite 3G, Eden House,  
Enterprise Way  
Edenbridge, Kent TN8 6HF  
Great Britain

**FR BE**

Si vous avez des questions concernant ce produit ou en cas de réclamations, veuillez prendre contact avec notre centre de services (de préférence via e-mail).

E-Mail: [sav@bresser.fr](mailto:sav@bresser.fr)  
Téléphone\*: 00 800 6343 7000

**BRESSER France SARL**

Pôle d'Activités de Nicopolis  
314 Avenue des Chênes Verts  
83170 Brignoles  
France

\*Prix d'un appel local depuis la France ou Belgique

**NL BE**

Als u met betrekking tot het product vragen of eventuele klachten heeft kunt u contact opnemen met het service centrum (bij voorkeur per e-mail).

E-Mail: [info@bresserbenelux.nl](mailto:info@bresserbenelux.nl)  
Telefoon\*: +31 528 23 24 76

**BRESSER Benelux**

Smirnoffstraat 8  
7903 AX Hoogeveen  
The Netherlands

\*Het telefoonnummer wordt in het Nederland tegen lokaal tarief in rekening gebracht. Het bedrag dat u per gesprek in rekening gebracht zal worden, is afhankelijk van het tarief van uw telefoon provider; gesprekken vanuit het buitenland zullen hogere kosten met zich meebrengen.

**ES IT PT**

Si desea formular alguna pregunta sobre el producto o alguna eventual reclamación, le rogamos que se ponga en contacto con el centro de servicio técnico (de preferencia por e-mail).

E-Mail: [servicio.iberia@bresser-iberia.es](mailto:servicio.iberia@bresser-iberia.es)  
Teléfono\*: +34 91 67972 69

**BRESSER Iberia SLU**

c/Valdemorillo,1 Nave B  
P.I. Ventorro del Cano  
28925 Alcorcón Madrid  
España

\*Número local de España (el importe de cada llamada telefónica dependen de las tarifas de los distribuidores); Las llamadas des del extranjero están ligadas a costes suplementarios..