

Breville®

Live more effortless



Halo Flexi Air Fryer

11L multi-use cooking zone

VDF130

product safety

READ CAREFULLY AND KEEP FOR FUTURE REFERENCE

This appliance can be used by children aged from 8 years and above and persons with reduced physical, sensory or mental capabilities or lack of experience and knowledge if they have been given supervision or instruction concerning use of the appliance in a safe way and understand the hazards involved.

Children shall not play with the appliance.

Cleaning and user maintenance shall not be made by children unless they are older than 8 and supervised.

Keep the appliance and its cord out of reach of children less than 8 years.

This product must be positioned on a stable surface with the handles positioned to avoid the spillage of hot liquids.

Surfaces of the product are liable to get hot during use.

Never operate the product by means of an external timer or separate remote-control system.

Never immerse any part of the appliance or power cord and plug in water or any other liquid.

If the supply cord is damaged, it must be replaced by the manufacturer, its service agent or similarly qualified persons in order to avoid a hazard.

Ensure the appliance is kept clean after use. For details see the Care and Cleaning section. Pay particular care regarding items that can be immersed in water and/or a dishwasher.

- ⚠ Never use this appliance for anything other than its intended use. This appliance is for household use only. Do not use this appliance outdoors.
- ⚠ Always ensure that hands are dry before handling the plug or switching on the appliance.
- ⚠ Always use the appliance on a stable, secure, dry and level surface.
- ⚠ Ensure the appliance is switched off and unplugged from the supply socket if it is left unattended, when it is not in use or before cleaning. Never leave the appliance unattended when it is in use.
- ⚠ Never use this appliance with an external timer or separate remote-control system.
- ⚠ Always allow the appliance to fully cool down before cleaning or storing.
- ⚠ Do not use the appliance if it has been dropped, if there are any visible signs of damage or if it is leaking.
- ⚠ Never let the power cord hang over the edge of a work top, touch hot surfaces or become knotted, trapped or pinched.
- ⚠ Do not touch the external surfaces of the appliance during use as they may become very hot.
- ⚠ Only use spares or accessories that are recommended by the manufacturer.
- ⚠ Allow adequate space above and on all sides for air circulation.
- ⚠ Do not allow the appliance to touch any flammable material during use (such as curtains or wall coverings).
- ⚠ Care is required when using the appliance on surfaces that may be damaged by heat. The use of an insulated pad is recommended.

Parts

1. Control Panel
2. Cooking Compartment 1
3. Cooking Compartment 2
4. Storage Drawer
5. Basket x2
6. Air Flow tray x2
7. Small roasting tray x2
8. Large roasting tray x1
9. Small mesh tray x2
10. Removable basket handle
11. Middle partition (removable)
12. Clasp

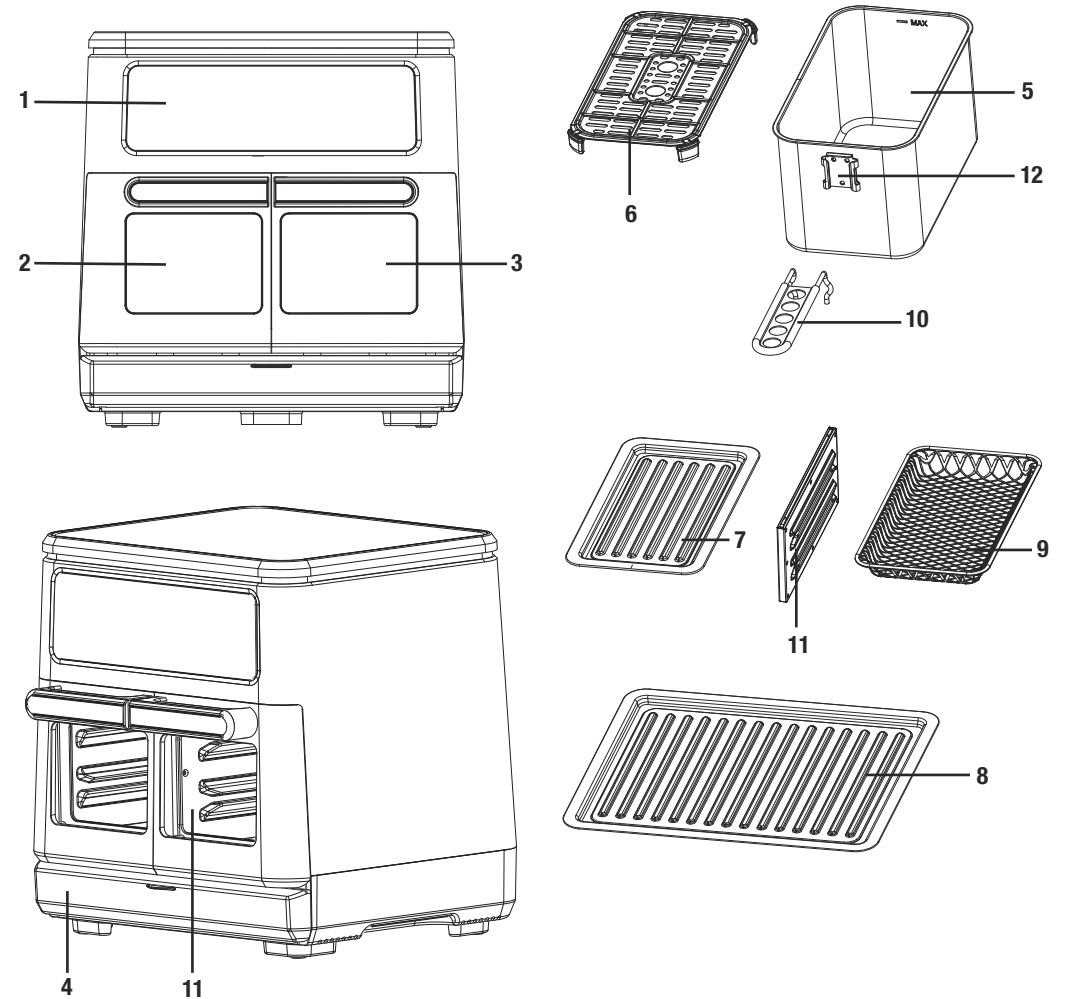

Control Panel

- | | |
|--|---------------------------|
| 13. Power | 20. Match Function |
| 14. Start / Pause | 21. Sync Function |
| 15. Temperature adjustment | 22. Cooking Compartment 1 |
| 16. Timer adjustment | 23. Cooking Compartment 2 |
| 17. Cooking functions: air fry, turbo crisp, roast, grill, bake, reheat, | 24. Light |
| 18. Presets: fries, chicken, meat and vegetables | 25. Temperature |
| 19. Manual cooking function | 26. Time |

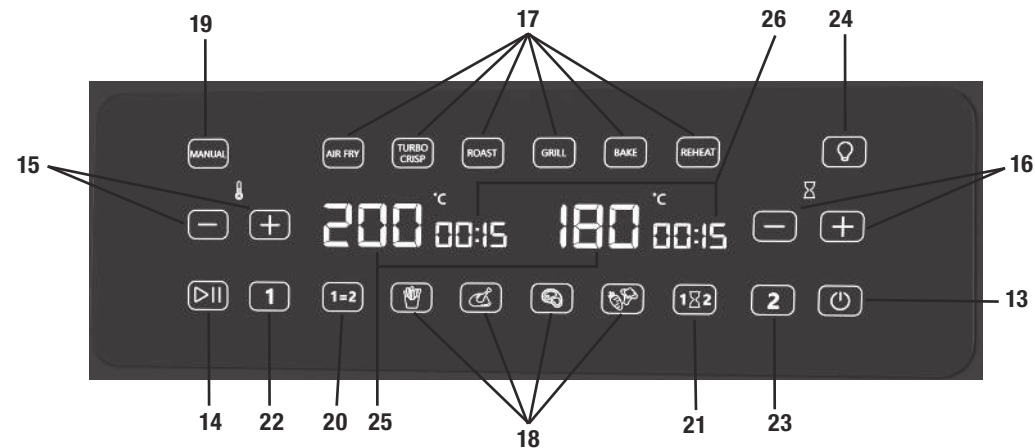

Cooking Function Chart

Functions	Temp	Time
Air Fryer	180°C	15 mins
Turbo Crisp	240°C	10 mins
Roast	180°C	60 mins
Grill	230°C	15 mins
Bake	160°C	30 mins
Reheat	120°C	10 mins
Manual	200°C	15 mins

Preset Chart

Functions	Temp	Time
Fries	200°C	20 mins
Chicken	170°C	60 mins
Steak	230°C	15 mins
Veg	170°C	15 mins

Preparing Your Air Fryer For First Use

1. Remove all packaging materials, stickers and labels in and on the Air Fryer.
2. Clean interior and accessories of the Air Fryer with a damp cloth, using only mild, soapy water. DO NOT IMMERSE THE AIR FRYER IN WATER. Abrasive cleaners, scrubbing brushes and chemical cleaners will damage the Air Fryer and accessories.
3. Place the Air Fryer on a flat surface.
4. Plug the Air Fryer into an electrical outlet.
5. Press the Power button (⏻) to turn the Air Fryer on. All the available functions will light up.
6. Select the match function (1=2), then air fry, then press start (▶||). The Air Fryer will run for 15 minutes to eliminate any remaining manufacturing residue.

Configuring Your Air Fryer

1. The Air Fryer can be used as two separate cooking compartments where each side can be programmed with different functions, times and temperatures, or as one large 11L cooking compartment by removing the Middle Partition.
2. After deciding on your configuration place the Air Fryer on a flat surface and plug in.

Removing the Middle Partition

1. Ensure the Air Fryer is cool. DO NOT remove the Middle Partition while the Air Fryer is hot.
2. Open both compartment doors.
3. Pull the Middle Partition towards you to slide it out of the Air Fryer.
4. The large roasting tray can be used when the partition is removed.
5. All functions and presets can be used when cooking in the large cooking compartment, however '1', '2', 'Sync' (1&2) and 'Match' (1=2) are not relevant to the large cooking compartment and so will not be available to select.

Re-inserting the Middle Partition

1. Ensure the Air Fryer is cool. DO NOT insert the partition whilst the Air Fryer is hot.
2. Fully open both compartment doors.
3. There is no 'wrong way' when re-inserting the Middle Partition. Align into the slots at the top and bottom of the cooking compartment and push gently until it touches the back wall. Once in place the Air Fryer will register it has been inserted and the user interface will allow you to set the program for the cooking compartments separately.

NOTE: If the doors will not close properly the Middle Partition has not been inserted into the cooking compartment correctly.

Choosing Your Accessories

- When using the small mesh trays place the small roasting trays on the rail below or on the bottom of the cooking compartment to collect any oil or crumbs.
- For best results when using the small roasting trays and mesh trays together in the same compartment, the roasting tray should be placed on lower rail only, with the mesh trays positioned above. This allows for better airflow and evenly cooked food.
- When using the baskets ensure the air flow trays are fully inserted until the rubber feet are on the bottom of the basket.
- When cooking frozen food using all 4 trays at once, we recommend increasing your cooking time by 3-4 minutes.

NOTE: When using either the small or large roasting tray on the highest shelf position, food with a high fat content can create more smoke, due to the proximity of the heating element.

- For best results and when baking larger cakes, bread and cookies, we advise baking with the Middle Partition removed and the large roasting tray placed on the bottom of the oven, with the basket or your own bakeware placed on the roasting tray. This allows better airflow around your chosen bakeware.

Programme – one side or large compartment only

1. Add food to your chosen accessory and place inside the cooking compartment, then close the door.
2. Press the power button (⏻).
3. Press the compartment button '1' or '2' according to where you've placed the food (not required when the Middle Partition is removed).
4. Choose the desired Function or Preset, or Manual.
5. If necessary, adjust the time (⌘) or temperature (Ⓢ) using the (+) and (-) buttons.
6. Press Start (▶▶).

Programme – both sides with the same settings (MATCH available)

1. Add food to your chosen accessories and place inside the cooking compartments, then close the doors.
2. Press the power button (⏻).
3. Press the Match button (1=2). The digital displays over both sides will be on during programming because these settings will apply to both sides (so you don't have to programme each side separately).
4. Choose the desired Function or Preset, or Manual.
5. If necessary, adjust the time (⌘) or temperature (Ⓢ) using the (+) and (-) buttons.
6. Press Start (▶▶).

Programme – both sides with different settings (SYNC available)

1. Add food to your chosen accessories and place inside the cooking compartments, then close the doors.
2. Press the power button (⏻).
3. Press the Button '1' to programme that compartment.
4. Choose the desired Function or Preset, or Manual.
5. If necessary, adjust the time (⌘) or temperature (Ⓢ) using the (+) and (-) buttons.
6. Press the Button '2' to programme that compartment and repeat steps 4 and 5. You can even choose the same function or preset but with a different time or temperature if you wish.
7. If each side has different cooking times but you wish both to finish together, press the SYNC button (1&2).
NOTE: to ensure optimum cooking there is a maximum holding time difference allowed between each side. If you require a greater time difference than the unit will allow then delay adding your food to that side by that extra amount of time.
8. Press Start (▶▶).

Cooking

1. After pressing Start (▶▶) the cooking compartment light will illuminate, the heat and fan will switch on and the time display will count down.
2. The light button (Ⓞ) can be pressed during cooking if you need to check your food with the door closed. It will automatically switch off after 30 seconds.
3. Press the Start/Pause button (▶▶) at any time to pause cooking, which suspends the time and switches off the heat. Re-press the button to continue cooking.
4. Opening the door during cooking will pause the programme, suspend the timer and switch off the heat. Closing the door will automatically restart the programme and continue cooking.
5. An audible alert will sound (5 times) and display 'FLIP' halfway through your programmed time as a reminder to turn your food or shake the basket for even cooking (see Air Fryer cooking chart for more details).
NOTE: If your food does not require turning you can ignore the beep. The audible alert will not sound when the bake or roast function are in use because foods cooking under these settings are unlikely to require turning.
6. Both compartment lights will illuminate 1 minute before the end to alert you that cooking is almost finished.
7. When cooking is finished an audible alert will sound (3 times) and the compartment lights will illuminate for 10 seconds before the Air Fryer automatically turns itself off.
8. Press the Power button (⏻) at any time to cancel cooking or to re-programme.

Additional Functions

- **Turbo Crisp:** If your food needs a final crisping, you can use the Turbo Crisp function for an additional 10 minutes of cooking: when normal cooking has finished press this button (it defaults to 10 minutes) and press Start (▶▶).
- **SYNC (1&2):** Automatically syncs both cooking compartments to finish cooking at the same time even if they have different cooking times. The compartment with the longest cook time will start first, then the shorter cook time will begin, allowing both compartments to finish at the same time. This is ideal for cooking fast food style items, whether frozen or chilled. The maximum time difference between each side is pre-set, to allow the finished food quality of both compartments to be at their optimum.
- **MATCH (1=2):** The match button automatically sets both cooking compartments to the same time and temperature. This function can be used if you are cooking a large amount of the same food or different foods with the same cook time and temperature.
NOTE: When using the Sync or Match function both cooking compartments will pause cooking if only one door is opened. This is to allow the food to finish cooking at the same time. Once both doors are closed cooking will continue.

Helpful tips

1. The function temperature and timer are guidance only, please see Air Fryer Cooking Chart for details.
2. During cooking if the door is left open for 5 minutes or more the Air Fryer will go to sleep. Press the Power button (⏻) to wake the Air Fryer.
3. To remove the cooking baskets from the Air Fryer, you can use the removable handle. Squeeze the handle to insert into the clasp on the basket and use the same action to remove the handle. DO NOT remove the hot baskets without the handle.
4. Use a thick kitchen towel or oven proof gloves to remove trays from a warm cooking compartment.
5. After cooking carefully remove food with a heat safe cooking utensil. Do not put hot baskets, trays or food on a surface which is not heatproof. Use caution when tipping the baskets to remove food, to avoid spillage of oil or hot liquids.
6. The large and small cooking trays can be stored in the drawer when not in use. The smaller roasting trays and mesh baskets will nest into the large roasting tray to be placed in the storage drawer.
7. The cooking baskets can be stored in the cooking compartments when not in use.
8. During programming, or after a door is opened during cooking, the Air Fryer will automatically switch off if no user interaction within 5 minutes. Press the Power button (⏻) to restart programming.
9. If one side is already cooking and you wish to add food to the other side, simply press pause, then programme the other side as per the instructions 'Programme - one side or large compartment only.' Now add your food and press start. Both sides will now cook together.
10. DO NOT use metal utensils in combination with the accessories. It is recommend to use silicone based utensils.
11. When baking, we recommend placing bake-ware on top of the small or large roasting tray, this allows air flow underneath the bake-ware. The baskets, with the airflow trays removed are also suitable for baking.

Cleaning & Maintenance Of Your Air Fryer

1. Clean the Air Fryer and accessories after each use.
2. Before cleaning your Breville® Air Fryer, unplug it and allow it to cool.
3. To clean the interior of the Air Fryer wipe with a damp cloth using only mild, soapy water. DO NOT IMMERSE IN WATER. Abrasive cleaners, scrubbing brushes and chemical cleaners will damage the Air Fryer.
4. Empty the Air Fryer baskets and trays frequently to avoid accumulation of crumbs.
5. Baskets, trays, removable divider and handle are all dishwasher safe.

Air Fryer Cooking Chart

Food	Weight	Function/ Preset	Time	Temperature	Shake/Turn half way through cooking	Oil
POTATOES						
Hand Cut Fries	700g - 800g	Fries	30 – 35 mins	200°C	Yes	1 tbsp
Hand Cut Fries	250g	Fries	15 – 20 mins	200°C	Yes	½ tbsp
Frozen Fries, (Thick Cut)	500g – 700g	Fries	20 – 25 mins	200°C	Yes	No
Frozen Fries, (Thick Cut)	250g	Fries	13 – 15 mins	200°C	Yes	No
Frozen Fries, (Thin Cut)	500g – 700g	Fries	18 – 20 mins	200°C	Yes	No
Frozen Fries, (Thin Cut)	250g	Fries	10 – 12 mins	200°C	Yes	No
Frozen Sweet Potato fries	500g	Fries	15 – 18 mins	200°C	Yes	No
Frozen Hash Browns	600g	Fries	18 – 20 mins	200°C	Yes	No
Fresh Jacket Potatoes	1kg (4)	Air Fry	60 mins	180°C	No	No
MEAT/POULTRY/FISH						
Steak	250g (1)	Steak	10 – 15 mins	200°C	Yes	1 tsp
Pork Chops	600g (3)	Steak	15 – 20 mins	180°C	Yes	1 tbsp
Beef Burgers	340g (2)	Steak	16 – 18 mins	180°C	Yes	No
Leg of Lamb	2.0kg – 2.5kg	Roast	105 – 120 mins	170°C	No	No
Whole Roast Chicken	1.8kg – 2.2kg	Chicken	80 – 90 mins	170°C	No	No
Whole Roast Chicken	1.3kg – 1.6kg	Chicken	60 – 70 mins	170°C	No	No
Chicken Wings	1 kg	Chicken	30 – 35 mins	180°C	Yes	No
Salmon Fillet	480g (2)	Air Fry	12 – 15 mins	180°C	No	No
FROZEN FOODS						
Frozen Battered Fish	400g (2)	Air Fry	12 – 15 mins	180°C	Yes	No
Frozen Chicken Nuggets	400g	Air Fry	12 – 15 mins	180°C	Yes	No
Frozen Vegetable Burgers	450g (4)	Air Fry	15 – 20 mins	200°C	Yes	No
Frozen garlic bread slices	6 slices	Air Fry	6 – 8mins	180°C	Yes	No
VEGETABLES						
Frozen Onion Rings	400g	Air Fry	10 – 12 mins	180°C	Yes	No
Fresh Roasting Vegetables	800g	Veg	15 – 20 mins	170°C	Yes	1 tbsp

Troubleshooting

PROBLEM	POTENTIAL CAUSE	SOLUTION
Overcooked / Undercooked Foods	<ul style="list-style-type: none"> Incorrect temperature or time setting 	<ul style="list-style-type: none"> You may have to adjust the time and temperature to desired taste. Because your Air Fryer is smaller than your regular oven, it will heat up faster and generally cook in shorter periods of time.
Burning Smell	<ul style="list-style-type: none"> Food build-up inside fryer Cooking compartments 	<ul style="list-style-type: none"> Refer to “Cleaning Your Air Fryer” Section.
Touch panel interface is non-responsive	<ul style="list-style-type: none"> Panel is dirty or greasy Excess moisture on panel Controller is malfunctioning 	<ul style="list-style-type: none"> Ensure panel is clean and free of debris before using. Ensure panel is clean and dry, and use dry hands to operate. Unplug unit and let it rest for 60 seconds before plugging in again. If the error persists contact aftersales support.
Touch panel right hand side is non responsive	<ul style="list-style-type: none"> The middle partition is not in place The middle partition has not been inserted correctly 	<ul style="list-style-type: none"> Ensure the middle partition has been inserted as per the instructions (page 6).
Air Fryer will not start after programming	<ul style="list-style-type: none"> Door is open Time difference between sides in SYNC mode is too much 	<ul style="list-style-type: none"> Close the door. Reduce the time difference.

Fitting of a plug - for U.K. and Ireland only

⚠ This appliance must be earthed.

If the plug is not suitable for the socket outlets in your home, it can be removed and replaced by a plug of the correct type.

If the fuse in a moulded plug needs to be changed, the fuse cover must be refitted. The appliance must not be used without the fuse cover fitted.

If the plug fuse requires replacement, a fuse of the same rating as that fitted by the manufacturer must be used. In order to prevent a hazard do not fit a fuse of a lower or higher rating.

If the terminals in the plug are not marked or if you are unsure about the installation of the plug please contact a qualified electrician.

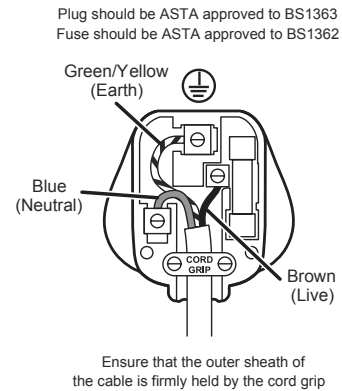

After sales service & replacement parts

In the case the appliance does not operate but is under warranty, return the product to the place it was purchased for a replacement. Please be aware that a valid form of proof of purchase will be required. For additional support, please contact our Consumer Service Department at: **United Kingdom: 0800 028 7154 | Spain: 0900 81 65 10 | France: 0805 542 055.**

For all other countries, please call **+44 800 028 7154**. International rates may apply. Alternatively, e-mail:

BrevilleEurope@newellco.com.

Waste Disposal

Waste electrical products should not be disposed of with household waste. Please recycle where facilities exist. E-mail us at BrevilleEurope@newellco.com for further recycling and WEEE information.



Breville®

Newell Brands UK Limited
5400 Lakeside, Cheadle Royal Business Park,
Cheadle, SK8 3GQ, United Kingdom
Newell Poland Services Sp. z o.o.,
Plac Andersa 7, Poznan, 61-894, Poland.
e-mail: BrevilleEurope@newellco.com
Telephone: 0800 028 7154



© 2023 Newell Brands UK Limited. All rights reserved.
Newell Brands UK Limited, 5400 Lakeside, Cheadle Royal Business Park, Cheadle, Cheshire, SK8 3GQ, United Kingdom.
Newell Poland Services Sp. z o.o., Plac Andersa 7, Poznan, 61-894, Poland.
Newell Brands UK Limited and Newell Poland Services Sp. z o.o. are subsidiaries of Newell Brands Inc.
The product you buy may differ slightly from the one shown on this carton due to continuing product development.
Made in China.