



105 Bonnie Drive  
Butler, PA 16002  
724-283-4681  
724-283-5939 (fax)  
www.bwieagle.com

# PRODUCT INFORMATION BULLETIN

## AIR-EAGLE® XLT 900MHz 20 Dry Contact Input Transmitter MODEL 441-12000-120VAC

### DESCRIPTION

The AIR-EAGLE XLT PLUS, MODEL 441-12000-120VAC RF TRANSMITTER IS a dry contact input transmitter designed to send up to twenty independent commands to an Air-Eagle Receiver(s) that can be located up to 2500 feet away. Any number of transmitters and receivers can be combined to create a system. The Air-Eagle XLT TX is user-programmable for up to eight network frequencies to allow multiple systems to operate simultaneously in the same area. Utilizing spread-spectrum technology this unit provides the utmost security and reliability even in the noisiest RF environments.

DISCONNECT Power from all equipment before installation.

1. Mount the AIR-EAGLE XLT TRANSMITTER in a convenient location.
2. Install wiring to contact input terminal strip
3. Make desired frequency and repeater mode selections using instructions on page 2.
4. Install antenna onto connector located on the top on the enclosure.
5. Connect supplied power input cable to your external power source.

### FREQUENCY & REPEATER MODE SET-UP

The unit is shipped from the factory with the SEL1 switches in the open positions. By default, it is operating on Frequency #1 and the command transmitted will not be repeated by the receivers. If you wish to transmit on a different frequency, and/or set the unit to transmit a repeating packet, follow the instructions on the table below.

1) Remove power from unit				
2) Remove top cover.				
3) Select desired frequency and/or repeater mode using table below.				
4) Reattach cover and apply power.				
5) Programming is now complete.				
REPEATER MODE				
SEL1 SWITCH NUMBER	OPEN		CLOSED	
SW4	Repeater Mode OFF (default)		Repeater Mode ON	
FREQUENCY SET-UP				
SEL1 (SW5-7)	Network Frequency	SW5	SW6	SW7
	1 (default)	OPEN	OPEN	OPEN
	2	CLOSED	OPEN	OPEN
	3	OPEN	CLOSED	OPEN
	4	CLOSED	CLOSED	OPEN
	5	OPEN	OPEN	CLOSED
	6	CLOSED	OPEN	CLOSED
	7	OPEN	CLOSED	CLOSED
8	CLOSED	CLOSED	CLOSED	
Note – Switches 1 thru 3 are not used on this model – leave OPEN				



Dimensions 8" L x 6" W x 4" H

### TERMINAL STRIP WIRING

BOTTOM TERMINAL BLOCK			
1	C Input #1	11	C Input #6
2	N/O Input #1	12	N/O Input #6
3	C Input #2	13	C Input #7
4	N/O Input #2	14	N/O Input #7
5	C Input #3	15	C Input #8
6	N/O Input #3	16	N/O Input #8
7	C Input #4	17	C Input #9
8	N/O Input #4	18	N/O Input #9
9	C Input #5	19	C Input #10
10	N/O Input #5	20	N/O Input #10
TOP TERMINAL BLOCK			
1	C Input #11	11	C Input #16
2	N/O Input #11	12	N/O Input #16
3	C Input #12	13	C Input #17
4	N/O Input #12	14	N/O Input #17
5	C Input #13	15	C Input #18
6	N/O Input #13	16	N/O Input #18
7	C Input #14	17	C Input #19
8	N/O Input #14	18	N/O Input #19
9	C Input #15	19	C Input #20
10	N/O Input #15	20	N/O Input #20
AC INPUT TERMINAL BLOCK			
1	120 VAC Neutral	2	120 VAC Hot

# AIR-EAGLE® XLT

## 900 MHz 8 Input RF Transmitter

### MODEL 441-12000-120VAC

### CONTROLS AND INDICATORS

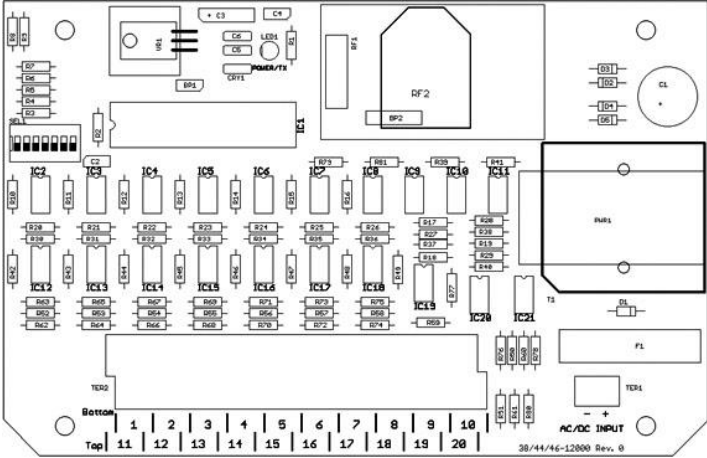

LED1	Illuminated green when power is applied. Changes to red when transmitting data.
Inputs 1 thru 8	Eight normally open dry contact inputs
SEL1	Dip switch bank for selecting operating frequency & repeater mode
RF2	RF module that transmits data to the remote receiver

### APPROVALS

United States (FCC)	MCQ-XB900HP
Canada (IC)	1846A-XB900HP

### SPECIFICATIONS

AC Input	120 VAC, 16 W, 50/60 Hz
Fuse Protected	1 amp
RF Frequency	900 MHz Spread Spectrum
Input Channels	20 Dry Contact Inputs
RF Output Power	250 mW
Transmitter Range	Up to 2500 feet with standard antenna
<small>Note: Max range figures are estimates, based on free-air terrain with limited sources of interference. Actual range will vary based on transmitting power, orientation of transmitter and receiver, height of transmitting antenna, height of receiving antenna, weather conditions, interference sources in the area, and terrain between receiver and transmitter, including, but not limited to, indoor and outdoor structures such as walls, metal objects, trees, buildings, hills, and mountains</small>	
Transmitter Frequencies	8 Independent Network Frequencies
Antenna Connection	TNC Bulkhead
Enclosure	Fiberglass / NEMA 4, 12 + 13
Operating Temperature	-40° F to +185° F

### ACCESSORIES

Standard Antenna (Included):	
900MHz TNC "Rubber Duck" Antenna	49-1103
High Gain Antennas – Used to help achieve max range in both non line of sight and line of sight applications. - Contact BWI Eagle for recommendations	
900MHz Thru-Hole Mount Omni Directional Antenna	49-2101
900MHz Magnet Mount Omni Directional Antenna	49-2102
900MHz Omni Directional Antenna	49-3101
900MHz Yagi Antenna	49-3102
High Quality Coax Cables – Used to connect external high gain antennas to control unit	
Flex Coax Cable w/Connectors – Available in 5', 15', 25', 30', 40', 60', 80', 100' Lengths	49-4000-XX (XX = # of Feet)
Bulkhead Extensions – Used to provide an external antenna connection when mounting control unit inside another enclosure	
TNC Male to TNC Bulkhead Cable Assembly - Available in 2', 4', 7' Lengths	49-5004-X-ISO (X = # of Feet)

### LIMITED WARRANTY STATEMENT

BWI Eagle Inc. warrants the Air-Eagle Remote Control System, if properly used and installed, will be free from defects in material and workmanship for a period of 1 year after date of purchase. Said warranty to include the repair or replacement of defective equipment. This warranty does not cover damage due to external causes, including accident, problems with electrical power, usage not in accordance with product instructions, misuse, neglect, alteration, repair, improper installation, or improper testing. This limited warranty, and any implied warranties that may exist under state law, apply only to the original purchaser of the equipment, and last only for as long as such purchaser continues to own the equipment. This warranty replaces all other warranties, express or implied including, but not limited to, the implied warranties or merchantability and fitness for a particular purpose. BWI Eagle makes no express warranties beyond those stated here. BWI disclaims without limitation, implied warranties of merchantability and fitness for a particular purpose. Some jurisdictions do not allow the exclusion of implied warranties so this limitation may not apply to you. To obtain warranty service, contact BWI Eagle for a return material authorization. When returning equipment to BWI Eagle, the customer assumes the risk of damage or loss during shipping and is responsible for the shipping costs incurred.

DOCUMENT DATE: 10/21/2021 / PRODUCT REV. 1



105 Bonnie Drive  
Butler, PA 16002  
(724) 283-4681  
Fax (724) 283-5939  
[www.bwieagle.com](http://www.bwieagle.com)



105 Bonnie Drive  
Butler, PA 16002  
724-283-4681  
724-283-5939 (fax)  
www.bwieagle.com

# DRY CONTACT INPUT WIRING 20-Input Transmitter

### Standard wiring of a dry contact input transmitter

Shorting together the contacts of the respective channel will cause it to transmit. This can be done with any type of manual or automatic switch.

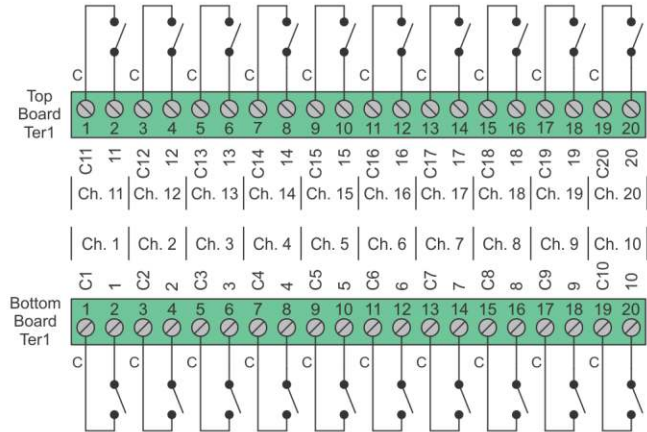

### Standard Wiring for Common Ground Applications

Because each channel shares a common (C) terminal, inputs can be wired as shown to allow for fewer conductors to be run to the transmitter.

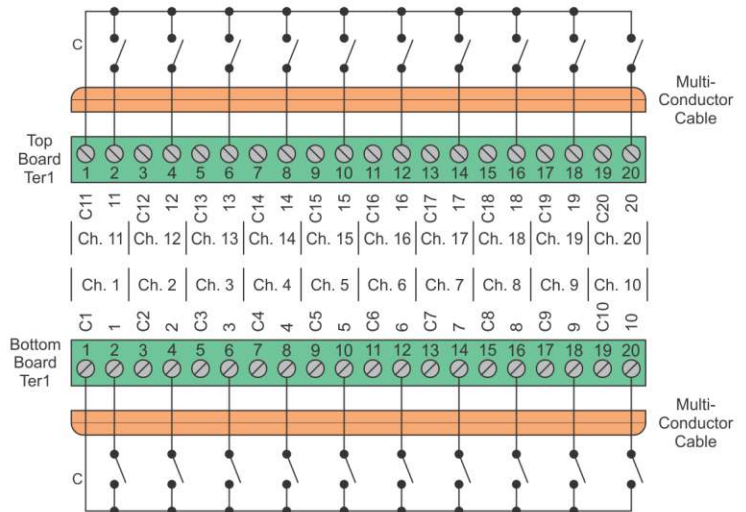

### SPDT Switches

The common (C) terminal of the switch only needs to be connected to one of the channels ground terminal. In this configuration ten channels would be transmitting all the time. A switch with a center "off" position would allow transmitting to stop.

In this example channels 2, 4, 6, 8, 10, 12, 14, 16, 18, and 20 are transmitting.

