

Canon

RF

10-20mm F4 L IS STM

Instructions

ENG

Thank you for purchasing a Canon product.

Canon RF10-20mm F4 L IS STM is a ultra-wide zoom lens for use with EOS R series cameras.

- “IS” stands for Image Stabilizer.
- “STM” stands for Stepping Motor.

Conventions used in these instructions



Warning to prevent lens or camera malfunction or damage.



Supplementary notes on using the lens and taking pictures.

Camera Firmware and Camera Applications

Please use the latest versions of firmware and applications with the camera in use. For details on whether the firmware and applications in use are the latest version or not, and for details on updating them, please check the Canon website.



If the camera's* firmware is not a compatible version, the following limitations will apply.

- Magnified view functionality is not available.
- In some cases, the camera malfunction may occur.

* Applies to the following camera models:
EOS R and EOS RP

Safety Precautions

Precautions to ensure that the camera is used safely. Read these precautions thoroughly. Make sure all details are observed in order to prevent risks and injury to the user and other people.



Warning

Details pertaining to risks that may result in death or serious injury.

- **Do not look directly at the sun or other strong light sources through a lens.** This may result in loss of sight.
- **Do not leave a lens in the sun without the lens cap attached.** The lens may concentrate entering sunlight and cause a malfunction or fire.



Caution

Details pertaining to risks that may result in injury or damage to other objects.

- **Do not leave the product in places exposed to extremely high or low temperatures.** The product may cause burns or injury when touched.

General Precautions

Handling Precautions

- Do not leave the product in excessive heat such as in a car in direct sunlight. High temperatures can cause the product to malfunction.
- If the lens is taken from a cold environment into a warm one, condensation may develop on the lens surface and internal parts. To prevent condensation in this case, first put the lens into an airtight plastic bag before taking it from a cold to warm environment. Then take out the lens after it has warmed gradually. Do the same when taking the lens from a warm environment into a cold one.
- In order to optimize aperture control, there are occasions in which the aperture blades will move during zooming and focusing, even when the aperture value is set for aperture-priority AE or manual exposure, etc.
- Please also read any lens related handling precautions listed in your camera's instruction manual.

Shooting Precautions

- This lens has a short focus distance, which means dirt or dust on the surface of the front lens will show up easily on photos. Use a commercially-available blower to remove dirt or dust from the front lens surface.

- This lens has a wide shooting angle, meaning sunlight or other strong light sources can enter the image easily. This can lead to flares or ghosts under some shooting conditions. To prevent this, we recommend being aware of where the light source is, such as photographing from shadows or other places where a strong light source will not enter the lens.

Video Shooting Precautions

- The lens is compatible with focus breathing correction* when shooting video.
 - * This refers to a function to correct for and reduce changes in view angle that occur when focus changes.
- Please refer to the Canon website or the camera's User Manual to check if your camera allows focus breathing correction, how to set it, and points to note about it.
- This lens covers an ultra-wide angle, so in some circumstances there may be image distortions or slight movement around the sides of the frame when focusing using focus breathing correction. In that event, it might be reduced by the following:
 - Change the focal length of the lens you are using to telephoto.
 - Reduce the focus speed. (Slow the AF speed for Movie Servo AF.)
 - Increase the f-stop. (It does not reduce the slight movements around the edge of the frame.)

This device complies with Part 15 of the FCC Rules.

Operation is subject to the following two conditions: (1) This device may not cause harmful interference, and (2) this device must accept any interference received, including interference that may cause undesired operation.

Do not make any changes or modifications to the equipment unless otherwise specified in the instructions. If such changes or modifications should be made, you could be required to stop operation of the equipment.

This equipment has been tested and found to comply with the limits for a class B digital device, pursuant to part 15 of the FCC Rules. These limits are designed to provide reasonable protection against harmful interference in a residential installation. This equipment generates, uses and can radiate radio frequency energy and, if not installed and used in accordance with the instructions, may cause harmful interference to radio communications.

However, there is no guarantee that interference will not occur in a particular installation. If this equipment does cause harmful interference to radio or television reception, which can be determined by turning the equipment off and on, the user is encouraged to try to correct the interference by one or more of the following measures:

- Reorient or relocate the receiving antenna.
- Increase the separation between the equipment and receiver.
- Connect the equipment into an outlet on a circuit different from that to which the receiver is connected.
- Consult the dealer or an experienced radio/TV technician for help.

Nomenclature

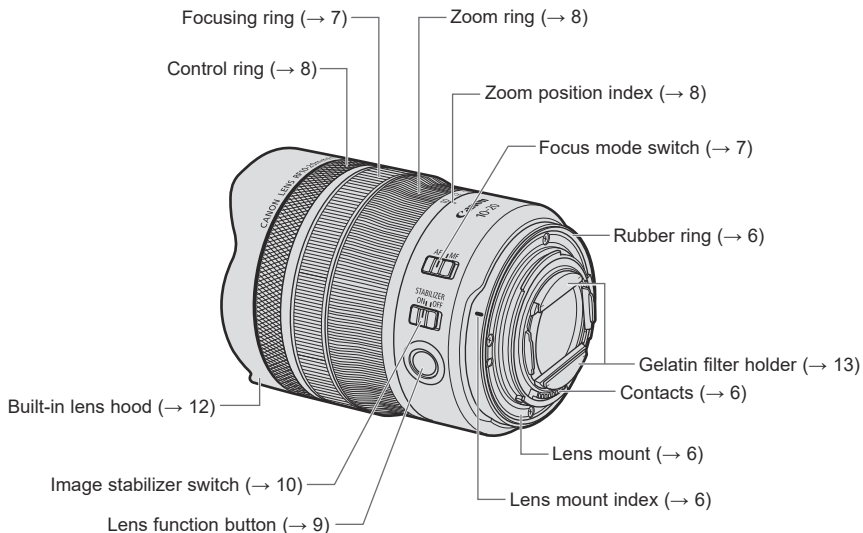

- For detailed information, reference page numbers are provided in parentheses (→ **).

1. Attaching and Detaching the Lens

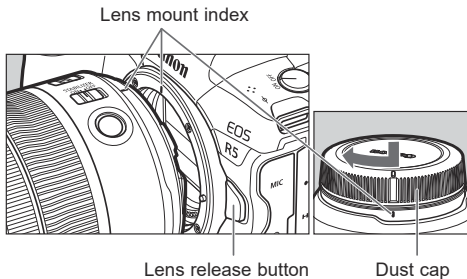

Attaching the Lens

Align the lens mount indexes of the lens and camera, and turn the lens clockwise until you hear a click.

Detaching the Lens

Turn the lens counterclockwise while pressing the camera's lens release button. Detach the lens once it has stopped turning.

Please refer to the camera's instructions for details.



- Set the camera's power switch to OFF when attaching or detaching the lens.
- Attach the lens cap before detaching the lens from the camera.
- After detaching the lens, place the lens with the rear end up and attach the dust cap to prevent the lens surface and contacts from getting scratched. Make sure the lens and dust cap mount indexes are aligned when attaching the dust cap.
- Contacts that are scratched, soiled, or have fingerprints on them may result in faulty connections or corrosion, which may lead to malfunctions. If the contacts get soiled, clean them with a soft cloth.
- The lens mount has a rubber ring to improve dust-resistance and water-resistance performance. This rubber ring may cause friction marks to appear around the camera's lens mount, although this will have no effect on usage.



- Rubber rings can be replaced at Canon Service Center. (chargeable)

2. Setting the Focus Mode

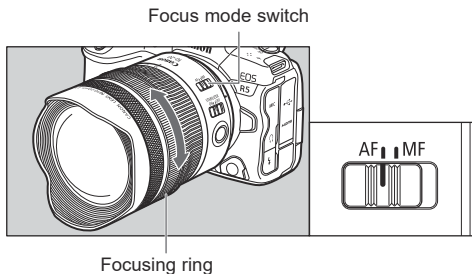

To shoot in autofocus (AF) mode, set the focus mode switch to AF.

To use only manual focusing (MF), set the focus mode switch to MF, and focus by turning the focusing ring.



- Quickly turning the focusing ring may result in delayed focus.



- The lens' focusing ring is electronic.
- It is possible to set cameras that support electronic fulltime manual focusing to manual focusing when the camera is in the operational mode. However, the camera settings need to be changed.
- When AF operation is set to One-Shot AF, manual focus is possible after autofocus has been completed by continuing to press the shutter button halfway (electronic manual focus function). However, the camera settings need to be changed.
- When movie recording, the AF speed will be slower than the still photo shooting mode. It is possible to adjust the AF speed on the camera by setting Movie Servo AF to [Enable].

Please refer to the camera's instructions for details.

3. Zooming

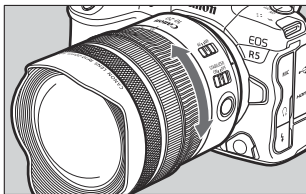

To zoom, turn the lens' zoom ring.

- Be sure to finish zooming before focusing. Zooming after focusing can affect the focus.
- Blurring may temporarily occur if the zoom ring is quickly turned.

4. Control Ring

The control ring can be assigned the functions that are commonly used with cameras, such as shutter speed and aperture settings.

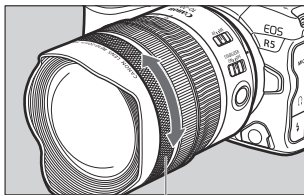

Control ring

The click action of the control ring allows you to have a sense of how much it is being turned. Please refer to the camera's instructions for details on how to use the control ring.

- There are cases in which the sound of control ring operations may be recorded when shooting movies.
- The clicking sensation of the control ring can be removed by the Canon Service Center. (chargeable)

5. Lens Function Button (AF Stop Button)

In the default settings, the lens function button serves as a AF stop button. You can assign different functions to the button from the [Customize buttons] section of the camera. Please refer to the camera's instructions for details.

Lens function button
(AF stop button)

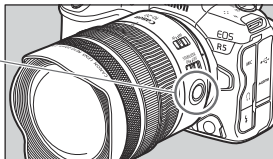

Use as a AF stop button

During autofocus operation, you can press an AF stop button to temporarily pause autofocus, and then release the button to resume.

Press an AF stop button to maintain a focusing distance or to avoid focus search.

Press the shutter button while holding down an AF stop button to shoot at that focusing distance.

- Useful when autofocus is operating mostly in Servo AF.

6. Image Stabilizer

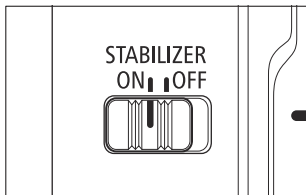

Set the image stabilizer switch to ON when you want to use the Image Stabilizer.

- This function provides image stabilization appropriate for shooting conditions (such as shooting still subjects and panning shots).
- The coordinated control will work in combination with cameras with in-body Image Stabilizer.
- Supports peripheral control** using coordinated control with the camera*.
- Set the image stabilizer switch to OFF when you are not going to use the Image Stabilizer.

- ❗ ● The Image Stabilizer cannot compensate for a blurred shot caused by a subject that moved.
- The Image Stabilizer may not be fully effective if you shoot from a violently shaking vehicle or other transportation.
- When using a tripod, the Image Stabilizer might not be fully effective or it might be better to set the image stabilizer switch to OFF, depending on the type of tripod and where the tripod is located, as well as on the camera's settings such as shutter speed.
- Even with a monopod, the Image Stabilizer will be as effective as during hand-held shooting. However, depending on the shooting conditions, there are cases in which the Image Stabilizer effect may be less effective.

* Please use the latest version of firmware with the camera.

For supported cameras, details on whether the firmware is the latest version, and how to update, please check the Canon website.

**In addition to normal control, this reduced changes of the distortion around the screen periphery that often happen due to shaking with wide-angle lenses.

Image Stabilizer

The Image Stabilizer for this lens is suited to hand-held shots in the following conditions.



- In semi-darkened areas such as indoors or outdoors at night.
- In locations where the flash cannot be used, such as art museums and theater stages.
- In situations where your footing is uncertain.
- In situations where fast shutter speed settings cannot be used.



- Panning shots of vehicles, trains, etc.
It compensates for vertical camera shake during panning shots in a horizontal direction, and compensates for horizontal camera shake during panning shots in a vertical direction.

7. Lens Cap

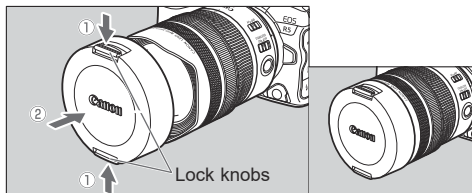

The lens cap can be attached by pinching the lock knobs and vertically aligning the lens cap with the built-in lens hood as shown in the diagram.

- The recessed sections of the lens hood that the cap locks on to are located at the front inside edge of the top and bottom petals.

8. Filters (Sold separately)

This lens has a gelatin filter holder at the rear.

Download the filter template files, print them out, then lay the filter over the template and cut to match. Then insert the filter in the holder.

1 Cut the gelatin filter to match the shape of the filter appropriate for your camera's image sensor size.

- Download the filter template file (PDF).
- Print the filter template out at full size (100%), and use it as the template to cut out the filter.
- The templates on this page are printed at full size, so can also be used. The filter template file is the same as this figure.

For full-frame cameras

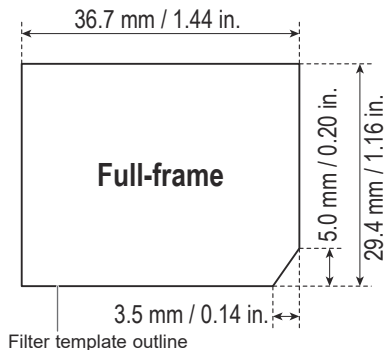

For APS-C cameras

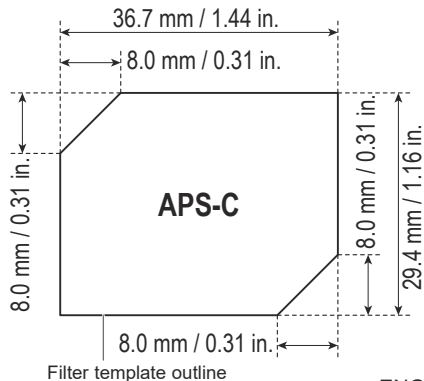

Filters (Sold separately)

- Only one gelatin filter with a thickness of 0.2 mm/0.008 in. or less may be used.
- When printing the template, make sure that the illustration size remains the same. Check that the printed-out size is the same as the measurements shown in the illustration.
- Cut the filter to the shape that matches your camera's image sensor size.
- Cut along the middle of the lines printed on the filter template. Any deviation from the template line width can cause the following issues.

Note 1: If you cut inside the lines, light will come in around the edges of the filter, preventing it from working fully. In particular, there can be differences with exposure and color patches in the corners.

Note 2: If you cut outside the lines, it may not fit in the holder, or the filter corners could contact the camera, damaging the camera or filter.

Filters (Sold separately)

2 Insert the filter from the left or right of the holder, and get it all within the projections on both sides.

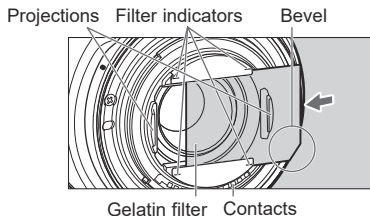

- Insert the filter into the holder so that the bevel is on the bottom right as shown in the figure on the left.
- Insert the filter so that it passes above the projections on the left and right.

With a full-frame filter in place

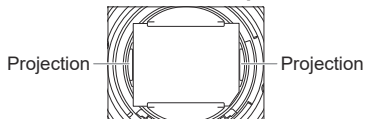

With an APS-C filter in place

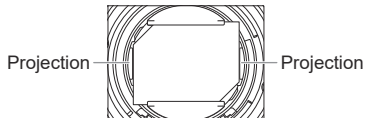

- Fit filter between the projections on the left and right.



- Check that the filter bevel is at the bottom right of the contacts.
- Image ghosting may occur as a result of using a gelatin filter. Also ensure that there is no dust or scratches on the gelatin filter.
- When inserting a gelatin filter, ensure that you do not touch the rearmost lens element.

Filters (Sold separately)

3 Check the filter after insertion.

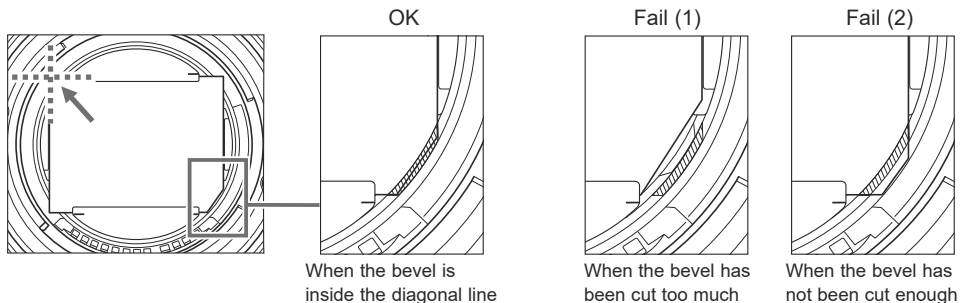

- When using a full-frame filter, check that the bevel at the bottom right is as shown in the OK example when the holder is on and the filter is pushed up to the top left.
- If the filter is as shown in Fail (1), then the issues in Note 1 (p.14) may occur. If the filter is as shown in Fail (2), then the issues in Note 2 (p.14) may occur.

- Take some test shots before shooting to check that the filter is working over the entire image.
- In particular, take a telephoto image of a white wall with even brightness to check in your camera viewfinder or on a monitor.
- The gelatin filter may come out of place due to shocks or vibrations.
- Check that the filter is correctly installed before shooting.
- When not using the camera for an extended period of time, remove the gelatin filter.

Specifications

Focal Length/Aperture	10-20mm f/4
Lens Construction	12 groups, 16 elements
Maximum Aperture	f/4
Minimum Aperture	f/22
Angle of View	Horizontal: 121°55' - 84°, Vertical: 100°25' - 62°, Diagonal: 130°25' - 94°
Min. Focusing Distance	0.25 m/0.82 ft.
Max. Magnification	0.12x (at 20 mm)
Field of View	Approx. 520 x 347 - 284 x 189 mm/ 20.47 x 13.66 - 11.18 x 7.44 in. (at 0.25 m/0.82 ft.)
Filter	Rear gelatin filter holder
Max. Diameter and Length	Approx. 83.7 x 112 mm/3.30 x 4.41 in.
Weight	Approx. 570 g/20.11 oz.
Hood	Inbuilt
Lens Cap	Lens Cap 10-20*
Lens Dust Cap	Lens Dust Cap RF*
Case	LP1219*

* This comes included with the lens, but can also be purchased separately.

Specifications

- The lens length is measured from the lens mount surface to the front end of the lens.
Add 23.3 mm/0.92 in. when including the lens cap and dust cap.
- The size and weight listed are for the lens only.
- You cannot use extenders.
- Multiple exposure shooting is not possible when using this lens on certain cameras*.
* EOS R, RP, Ra, R5, R6
- There are cases in which using the zoom function during continuous shooting may result in conspicuous image distortion.
- All data listed is measured according to Canon standards.
- Product specifications and appearance are subject to change without notice.

Canon