



# Installation Instructions

Part No: CRRFCURB040A00-042A00, 057A00-062A00, 064A00-069A00,  
50DJ-901-001, 091---011, 902---631, 902---641 and CRRFCURB070A00, 071A00

## CONTENTS

	Page
<b>SAFETY CONSIDERATIONS</b> .....	1
<b>INSTALLATION</b> .....	1
<b>Attaching the Ductwork</b> .....	15
<b>Flashing the Curb</b> .....	15
• GASKET	
• RIGID INSULATION	
• CANT STRIP	
• COUNTERFLASHING	
<b>Apply the Gasket Material</b> .....	17

## SAFETY CONSIDERATIONS

Installation of this accessory can be hazardous due to system pressures, electrical components, and equipment location (such as a roof or elevated structure). Only trained, qualified installers and service technicians should install, start-up, and service this equipment.

When installing this accessory, observe precautions in the literature, labels attached to the equipment, and any other safety precautions that apply:

- Follow all safety codes
- Wear safety glasses and work gloves
- Use care in handling and installing this accessory

It is important to recognize safety information. This is the safety-alert symbol: . When you see this symbol on the unit and in instructions or manuals, be alert to the potential for personal injury.

Understand the signal words DANGER, WARNING, CAUTION, and NOTE. These words are used with the safety-alert symbol. DANGER identifies the most serious hazards which **will** result in severe personal injury or death. WARNING signifies hazards which **could** result in personal injury or death. CAUTION is used to identify unsafe practices, which **may** result in minor personal injury or product and property damage. NOTE is used to highlight suggestions which **will** result in enhanced installation, reliability, or operation.

## WARNING

To prevent injuries and rain damage, do not leave roof opening uncovered. If installation is not completed immediately after roof opening is cut and framed, provide an adequate temporary cover for the roof opening.

## INSTALLATION

1. Before installing curb:
  - a. Verify curb usage on Table 1. Ensure the curb part number matches the unit configuration.
  - b. Verify all curb parts have been received per Tables 2-4.
  - c. Ensure that the curb is located so that proper service clearances are maintained on the unit. Check unit certified drawing or unit installation instructions for clearances.
  - d. Ensure that the curb can be installed within leveling tolerances. See unit leveling tolerances in Fig. 1-9 starting on page 4 for acceptable slope of unit.
2. Cut hole in roof for cross openings. See Fig. 1-9 for cross opening dimensions in curb. Do not cut out entire area underneath curb.
3. Frame the roof opening to provide adequate structural support.
4. Assemble the curb sides using the joining brackets and corner brackets as shown in Fig. 10 and 11. Corner brackets are used in 4 corners and can also be installed back to back to attach 2 cross supports. See Fig. 11 and 12 for bracket locations.
5. Attach the curb side assembly to the curb ends using the corner brackets as shown in Fig. 1-9.
6. Screw the cross supports in place on the curb sides as shown in Fig. 1-9.
7. Screw the supply support in place between the cross supports as shown in Fig. 1-9.
8. Make sure the curb is square by measuring (equal distances) the cross corners. Once square, attach curb to building structure following all applicable codes.

9. Roof-in curb according to Fig. 1-9 starting on page 4. Follow all applicable codes. Follow instructions in options a-c for applicable bracket type.

a. Joining Bracket:

Some long curb sides and ends may require a joining bracket which combines long pieces together using the factory provided flat bracket as shown in Fig. 10 on page 13. It is designed to align with the pre-punched holes in the knockdown curbs where the seams join, and must be installed on the inside of the curb.

Insert supplied bolts from the outside of the curb and secure. Insert wood screws at the top of the bracket and insert from the inside of the curb.

b. Corner Bracket:

Bring together curb side and curb end. Place the small corner bracket on the inside of the new knockdown curb and align with the pre-punched holes as show in Fig. 11

on page 13. Insert the bolts from the outside of the curb. Repeat for the assembly of all corners.

c. 90 Degree Joining Bracket:

Some long curb sides and ends may require a joining bracket. The joining bracket combines long pieces together using the provided 90 degree corner bracket as shown in Fig. 12 on page 14. Place and secure the metal brackets on the inside of the curb. It is designed to align with the pre-punched holes in the knockdown curbs where the seams join, and must be installed on the inside of the curb. Insert supplied bolts from the outside of the curb, and through the brackets where the two flanges meet, secure into place. Insert wood screws at the top of the bracket and insert from the inside of the curb.

10. Install provided gasketing around complete perimeter of curb and around supply and return cross opening in curb.

**Table 1 – Accessory Package Usage**

UNIT 48/50V (TONS)	PART NO.	USAGE	
		48V	50V
27.5-35	CRRFCURB057A00	48V STD Chassis	50V STD Chassis with Plenum
	CRRFCURB058A00	48V EXT Chassis	50V EXT Chassis with Plenum
	CRRFCURB064A00	—	50V STD Chassis
	CRRFCURB065A00	—	50V EXT Chassis
	CRRFCURB040A00	48V Low Heat CPT Chassis	50V CPT Chassis
	CRRFCURB041A00	48V High Heat CPT Chassis	—
40-50	CRRFCURB042A00	48V LH/HH CPT Chassis	50V CPT Chassis
	CRRFCURB059A00	48V STD Chassis	50V STD Chassis with Plenum
	CRRFCURB060A00	48V EXT Chassis	50V EXT Chassis with Plenum
	CRRFCURB066A00	—	50V STD Chassis
	CRRFCURB067A00	—	50V EXT Chassis
55-60	CRRFCURB068A00	—	50V STD Chassis
	CRRFCURB069A00	—	50V EXT Chassis
	CRRFCURB061A00	48V STD Chassis	—
	CRRFCURB062A00	48V EXT Chassis	—
70	50DJ-901---001	—	50V STD Chassis
	50DJ-902---641	—	50V EXT Chassis
70-100	50DJ-901---011	48V STD Chassis	50V STD Chassis with Plenum (70 Ton) 50V STD Chassis (75-100 Ton)
	50DJ-902---631	48V EXT Chassis	50V EXT Chassis with Plenum (70 Ton) 50V EXT Chassis (75-100 Ton)
70,75	CRRFCURB070A00	48/50V Condenser Section (70-75 Ton)	
90-100	CRRFCURB071A00	48/50V Condenser Section (90-100 Ton)	

LEGEND

- CPT — Compact Chassis
- EXT — Extended Standard Chassis
- LH — Low Heat
- HH — High Heat
- STD — Standard

**Table 2 – Package Contents – Standard and Extended Chassis**

ACCESSORY PART NO.	PACKAGE CONTENT									
	Corner Brackets	Cross Supports	Curb Ends	Curb Sides	Gasket	Hardware Package	Joining Bracket	Supply Air Support	Equipment Support	Deck Pan
CRRFCURB057A00	4	4	2	6	1	1	4	1	—	—
CRRFCURB058A00	4	4	2	6	1	1	4	1	—	—
CRRFCURB059A00	4	4	2	6	1	1	4	1	—	—
CRRFCURB060A00	4	4	2	6	1	1	4	1	—	—
CRRFCURB061A00	4	4	2	10	1	1	8	1	—	—
CRRFCURB062A00	4	4	2	8	1	1	6	1	—	—
CRRFCURB064A00	4	3	2	4	1	1	2	1	—	—
CRRFCURB065A00	4	4	2	6	1	1	4	1	—	—
CRRFCURB066A00	4	4	2	6	1	1	4	1	—	—
CRRFCURB067A00	4	4	2	6	1	1	4	1	—	—
CRRFCURB068A00	4	4	2	8	1	1	6	1	—	—
CRRFCURB069A00	4	4	2	8	1	1	6	1	—	—
50DJ-901---001	8	3	2	6	1	1	2	1	1	1
50DJ-901---011	8	4	2	6	1	1	2	1	1	1
50DJ-902---641	4	4	2	6	1	1	4	1	1	1
50DJ-902---631	8	4	2	6	1	1	2	1	1	1

**Table 3 – Package Contents – Compact Chassis**

ACCESSORY PART NO.	PACKAGE CONTENT							
	Corner Brackets	Cross Supports	Curb Ends	Curb Sides	Gasket	Hardware Package	Joining Bracket	Supply Air Support
CRRFCURB040A00	4	7	2	4	1	1	2	1
CRRFCURB041A00	8	7	2	4	1	1	—	1
CRRFCURB042A00	4	8	2	4	1	1	2	1

**Table 4 – Package Contents – 48/50V 70-100 Ton Full Perimeter Curb Conversion Kit**

ACCESSORY PART NO.	PACKAGE CONTENT							
	Corner Bracket	Cross Supports	Curb Ends	Curb Sides	Gasket	Hardware Package	Sloped Deck Pan	Splice Plate
CRRFCURB070A00	2	2	2	2	1	1	3	2
CRRFCURB071A00	2	3	4	2	1	1	4	4

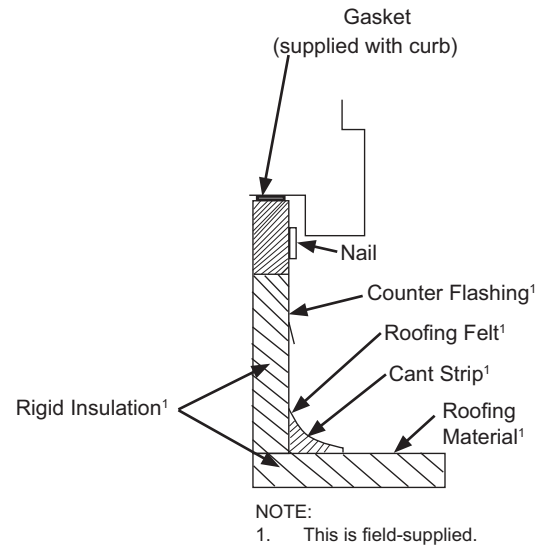
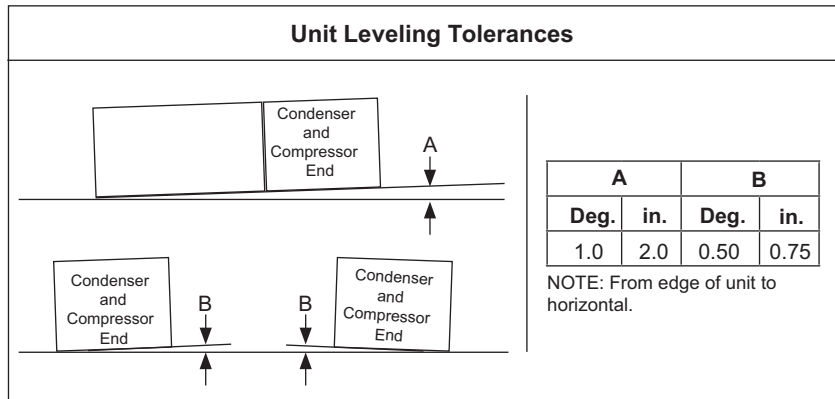

**IMPORTANT:** Gasketing is critical for water integrity. Improperly installed gasketing can result in air leaks and poor unit performance.

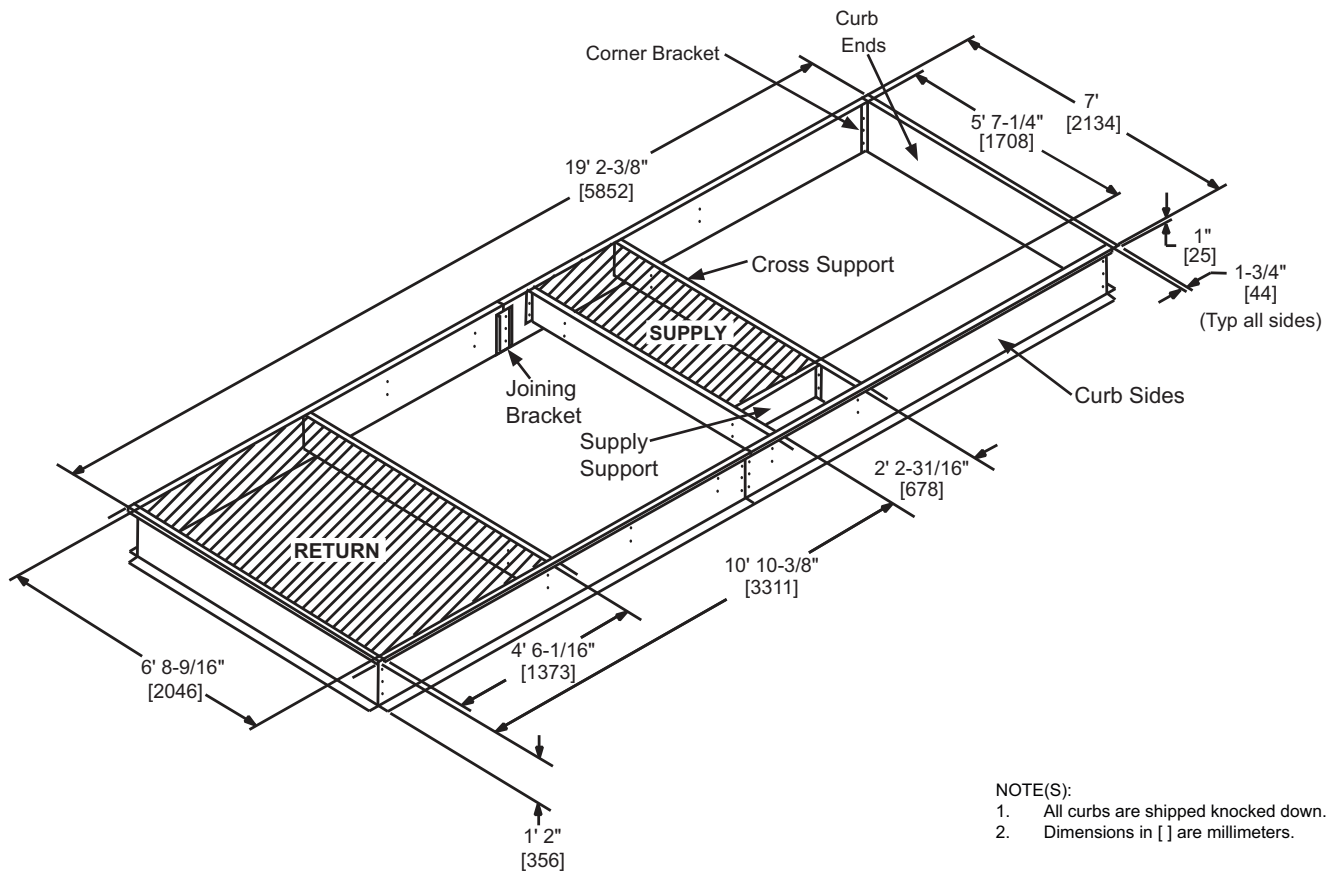

**Fig. 1 – Roof Curb Assembly (CRRFCURB064A00 Shown)**

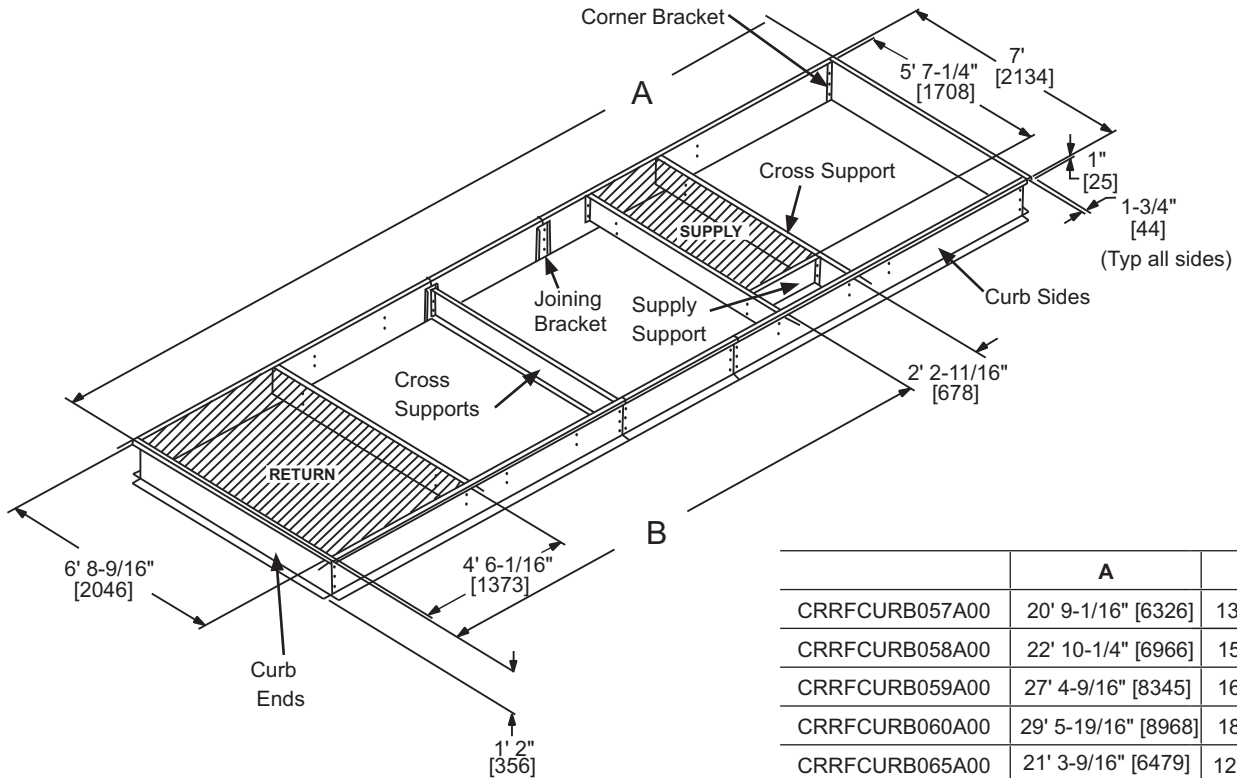
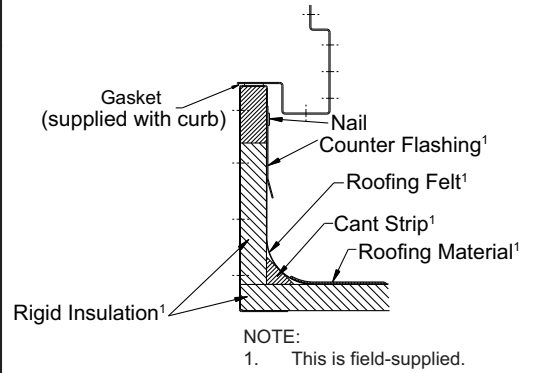
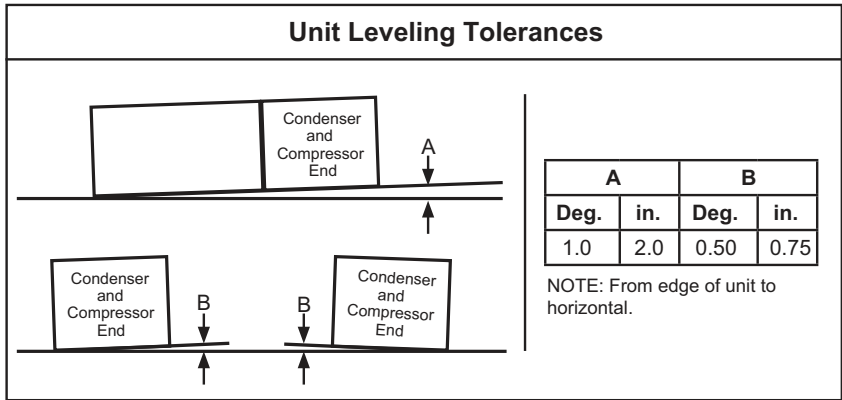

	A	B
CRRFCURB057A00	20' 9-1/16" [6326]	13' 3-1/16" [4040]
CRRFCURB058A00	22' 10-1/4" [6966]	15' 4-7/8" [4696]
CRRFCURB059A00	27' 4-9/16" [8345]	16' 5/8" [4893]
CRRFCURB060A00	29' 5-19/16" [8968]	18' 1-7/8" [5534]
CRRFCURB065A00	21' 3-9/16" [6479]	12' 11-9/16" [3951]
CRRFCURB066A00	25' 9-5/8" [7864]	13' 7-1/16" [4141]
CRRFCURB067A00	27' 10-3/16" [8488]	15' 8-7/32" [4781]

**IMPORTANT:** Gasketing is critical for water integrity. Improperly installed gasketing can result in air leaks and poor unit performance.

- NOTE(S):
- All curbs are shipped knocked down.
  - Dimensions in [ ] are millimeters.

**Fig. 2 – Roof Curb Assembly (CRRFCURB058A00 Shown)**

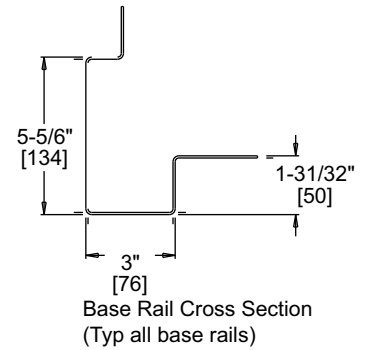
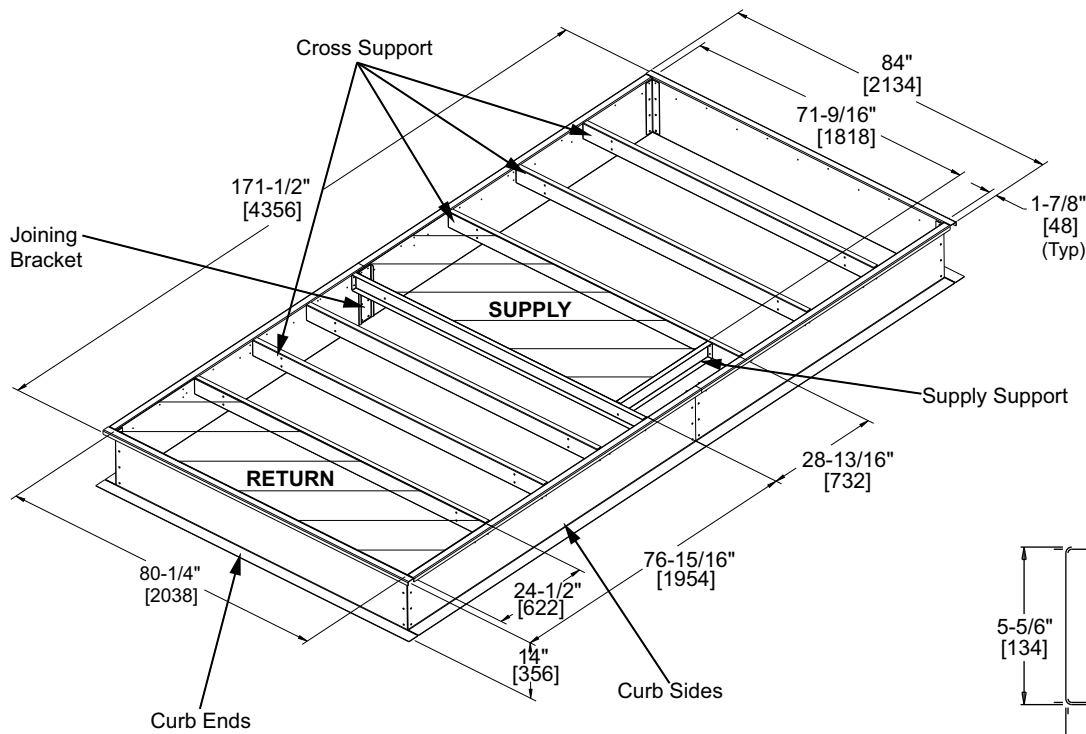
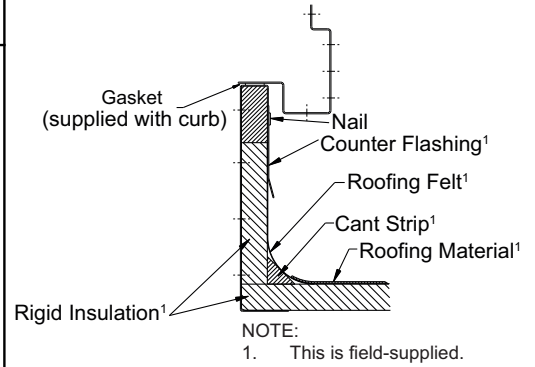
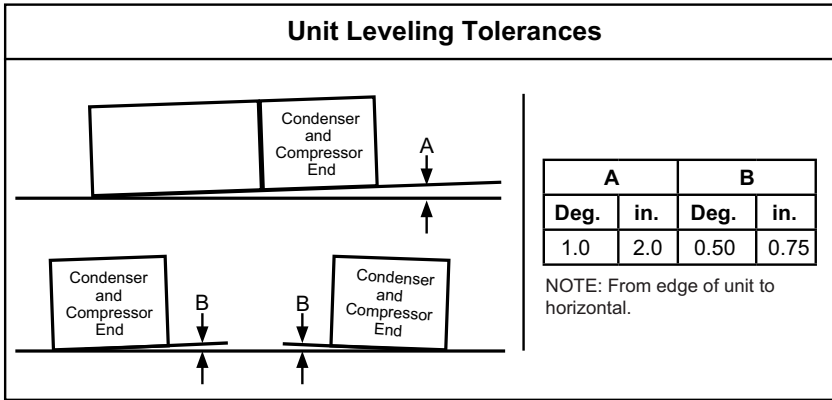

**IMPORTANT:** Gasketing is critical for water integrity. Improperly installed gasketing can result in air leaks and poor unit performance.

- NOTES:
1. This is field-installed.
  2. All curbs are shipped knocked down.
  3. Dimensions in [ ] are millimeters.

48VV006086 REV -

**Fig. 3 — Roof Curb Assembly (CRRFCURB040A00 Shown)**

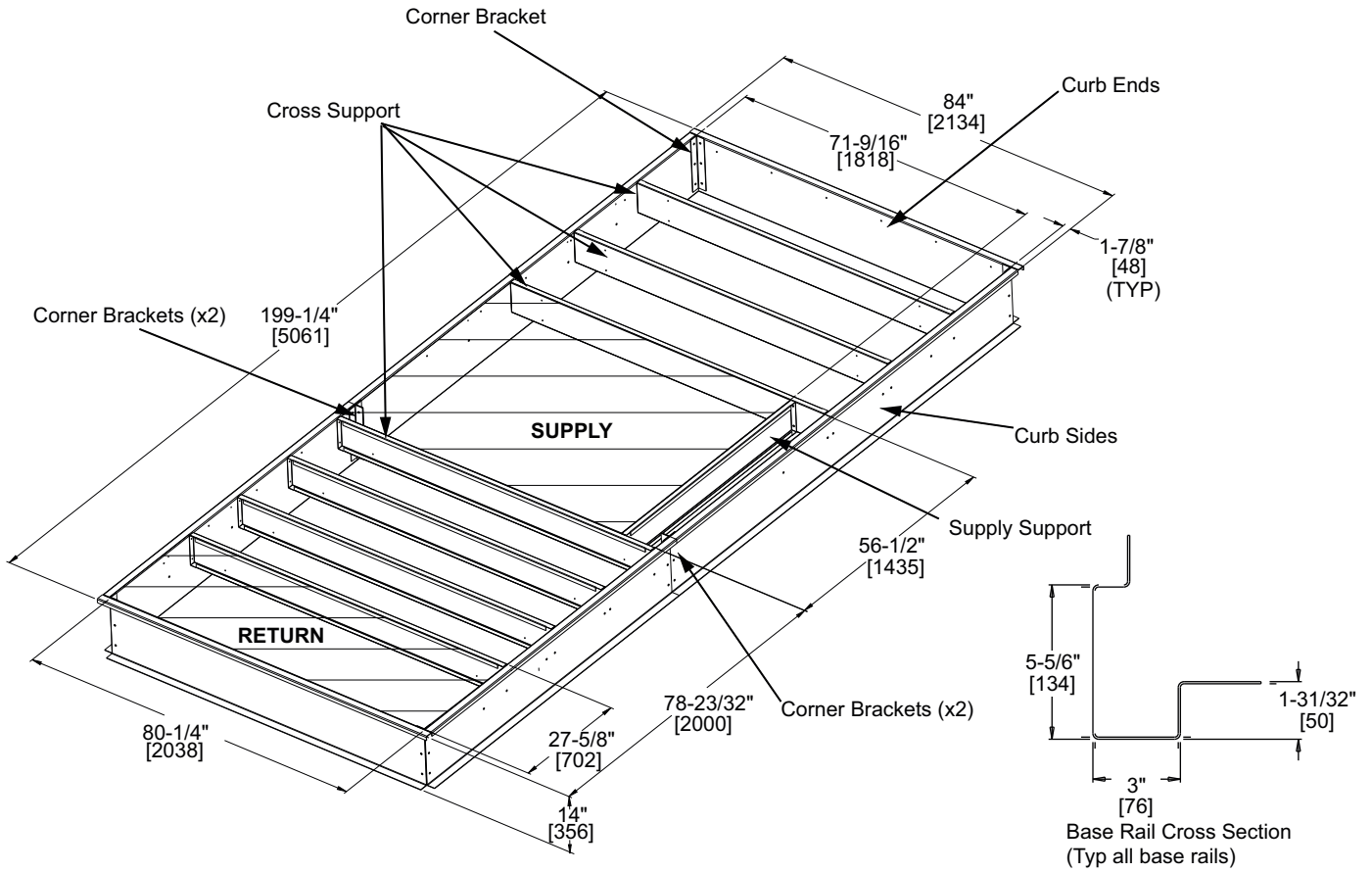
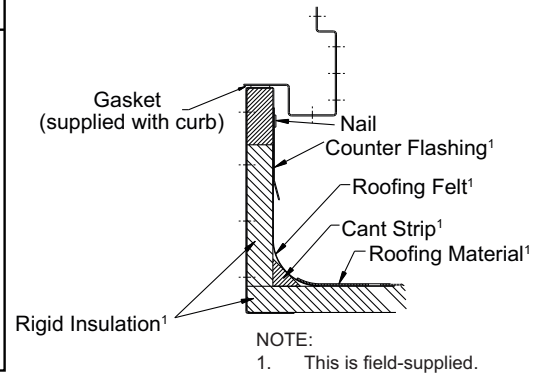
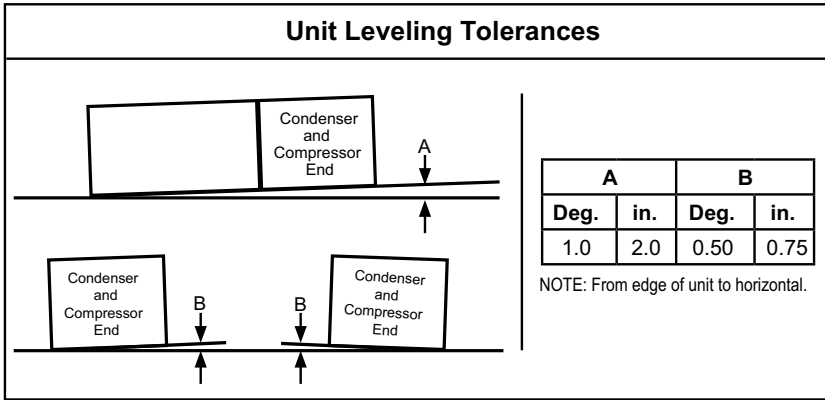

**IMPORTANT:** Gasketing is critical for water integrity. Improperly installed gasketing can result in air leaks and poor unit performance.

- NOTE(S):
1. This is field-supplied.
  2. All curbs are shipped knocked down.
  3. Dimensions in [ ] are millimeters.

48RV006087 REV -

**Fig. 4 – Roof Curb Assembly (CRRFCURB041A00 Shown)**

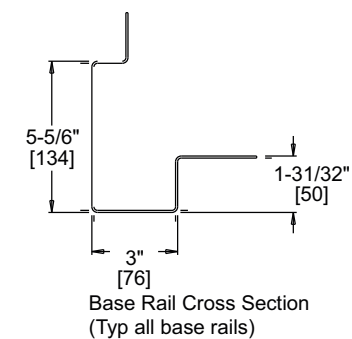
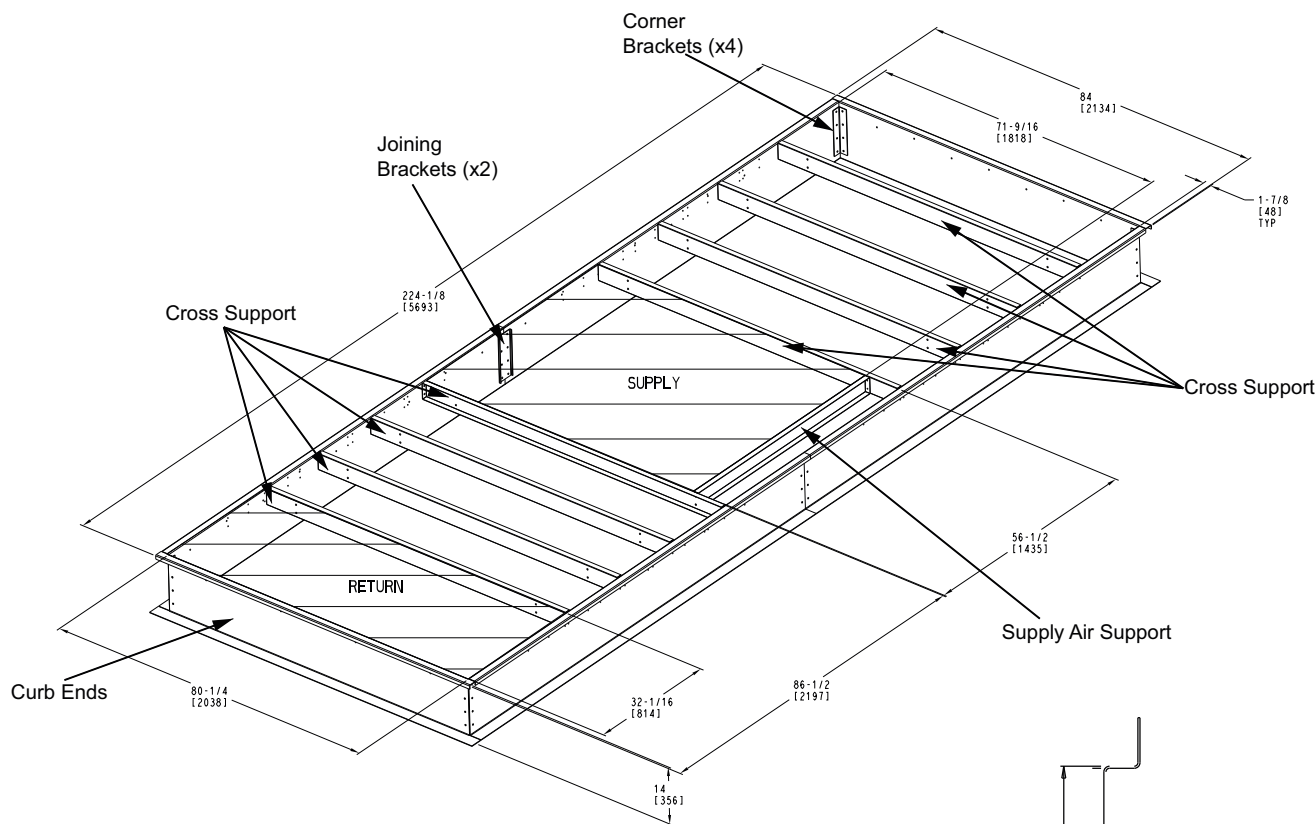
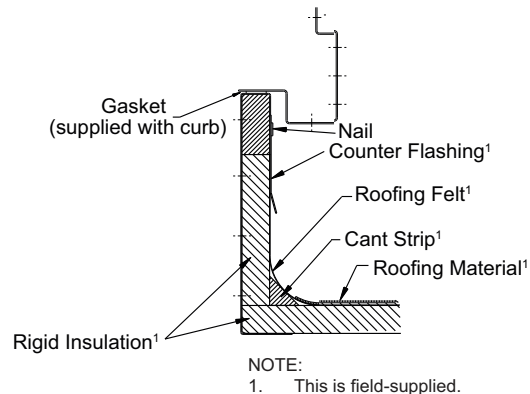
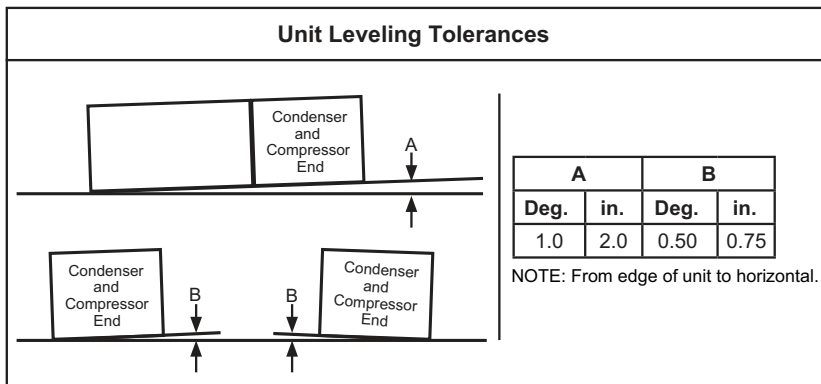

**IMPORTANT:** Gasketing is critical for water integrity. Improperly installed gasketing can result in air leaks and poor unit performance.

- NOTE(S):
1. This is field-supplied.
  2. All curbs are shipped knocked down.
  3. Dimensions in [ ] are millimeters.

ITC CLASSIFICATION U. S. ECCN:EAR99	SHEET 1 OF 1	DATE 03/11/25	SUPERCEDES 02/19/24	ROOF CURB ASSY	48VV007196	REV A
--	-----------------	------------------	------------------------	----------------	------------	----------

**Fig. 5 — Roof Curb Assembly (CRRFCURB042A00 Shown)**

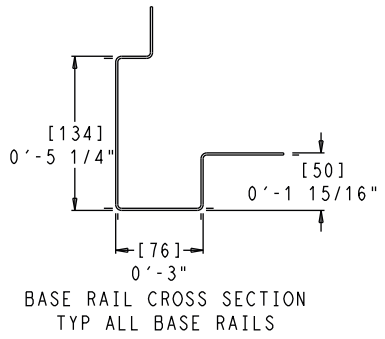
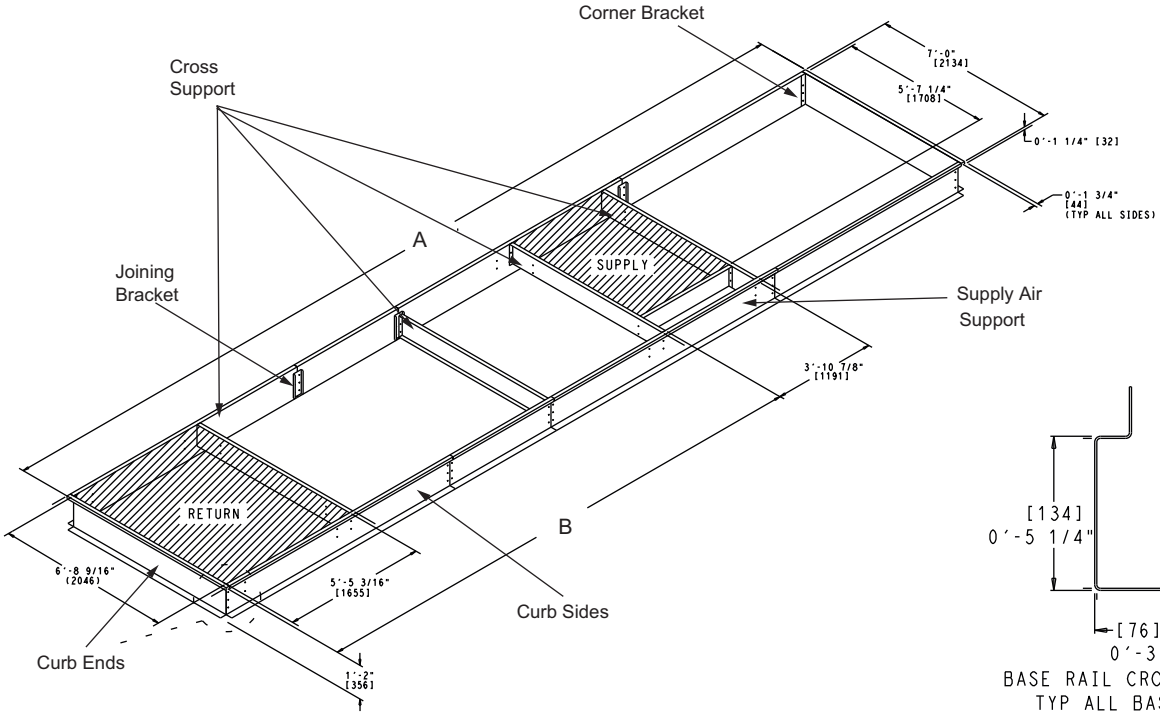
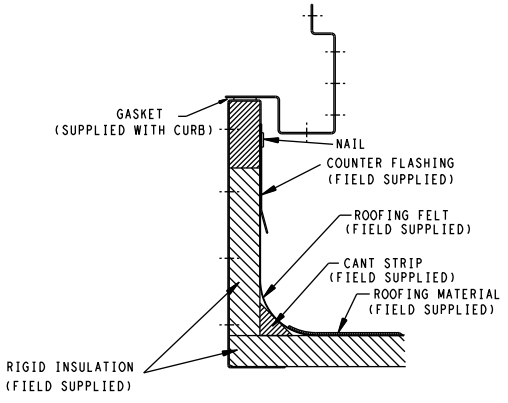
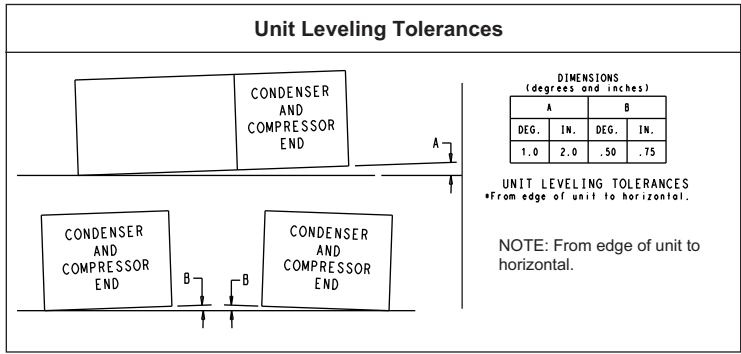

PART NO.	A	B
CRRFCURB061A00	35' 11-1/16"	22' 10-3/16"
CRRFCURB062A00	38' 0-1/4"	24' 11-3/8"
CRRFCURB068A00	32' 6-7/16"	19' 5-9/16"
CRRFCURB069A00	34' 7-5/8"	21' 6-3/4"

NOTE(S):  
 a. All curbs are shipped knocked down.  
 b. Dimensions are in inches [mm].

**Fig. 6 – Roof Curb Assembly 55-60 Ton**

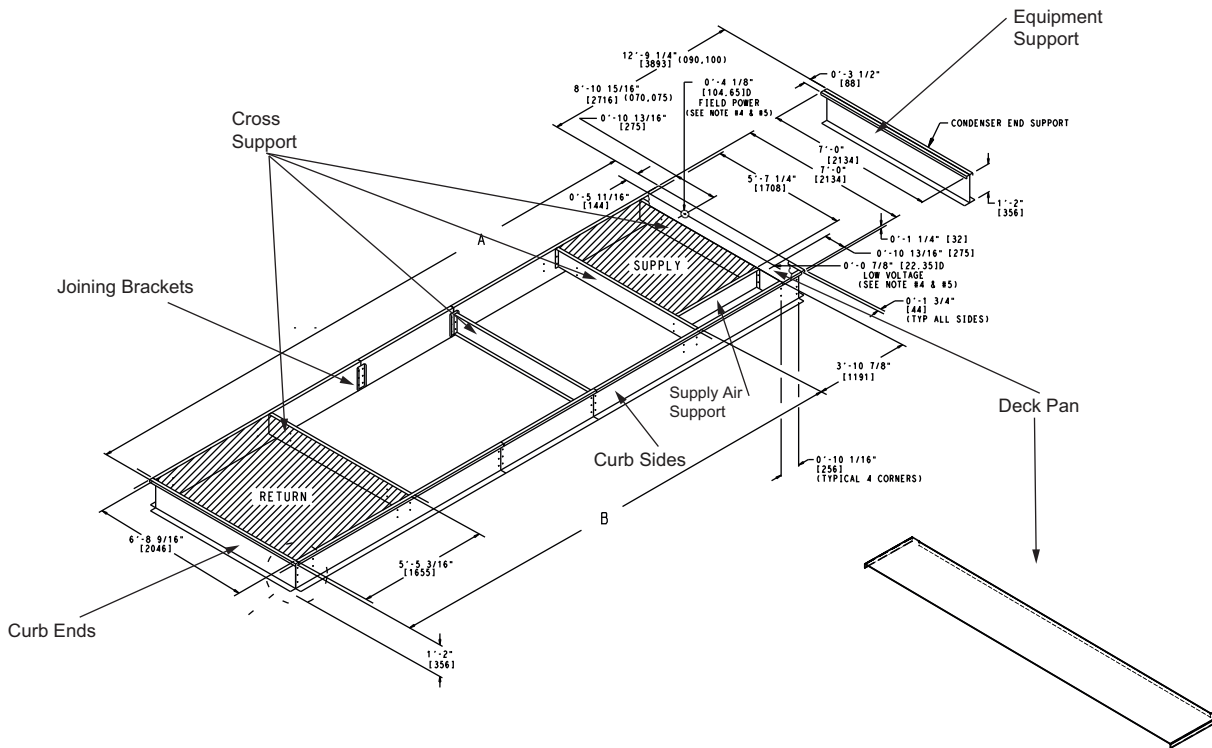
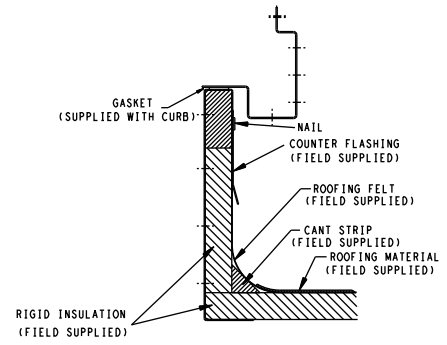
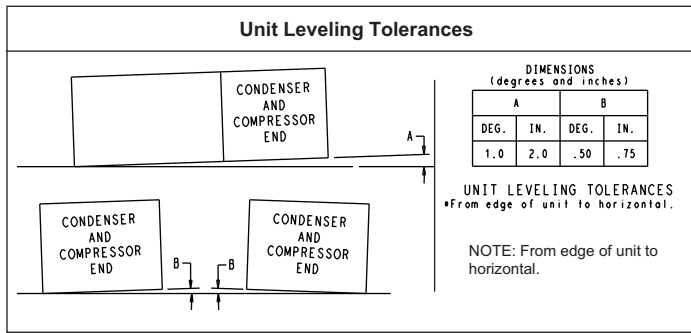

PART NO.	A	B
50DJ-901---001	24' 5-1/16"	19' 5-9/16"
50DJ-901---011	27' 9-11/16"	22' 10-3/16"
50DJ-902---631	29' 10-7/8"	24' 11-3/8"
50DJ-902---641	26' 6-1/4"	21' 6-3/4"

NOTE(S):

- a. All curbs are shipped knocked down.
- b. Dimensions are in inches [mm].

**Fig. 7 – Roof Curb Assembly 70-100 Ton**

- NOTES:
1. ROOF CURB ACCESSORY CRRFCURB070A00 IS SHIPPED DISASSEMBLED.
  2. DIMENSIONS IN [ ] ARE MILLIMETERS.
  3. ROOF CURB: 14 GA. [VA03-56] STL.  
ROOF CURB PANS: 16 GA. [VA03-56] STL.

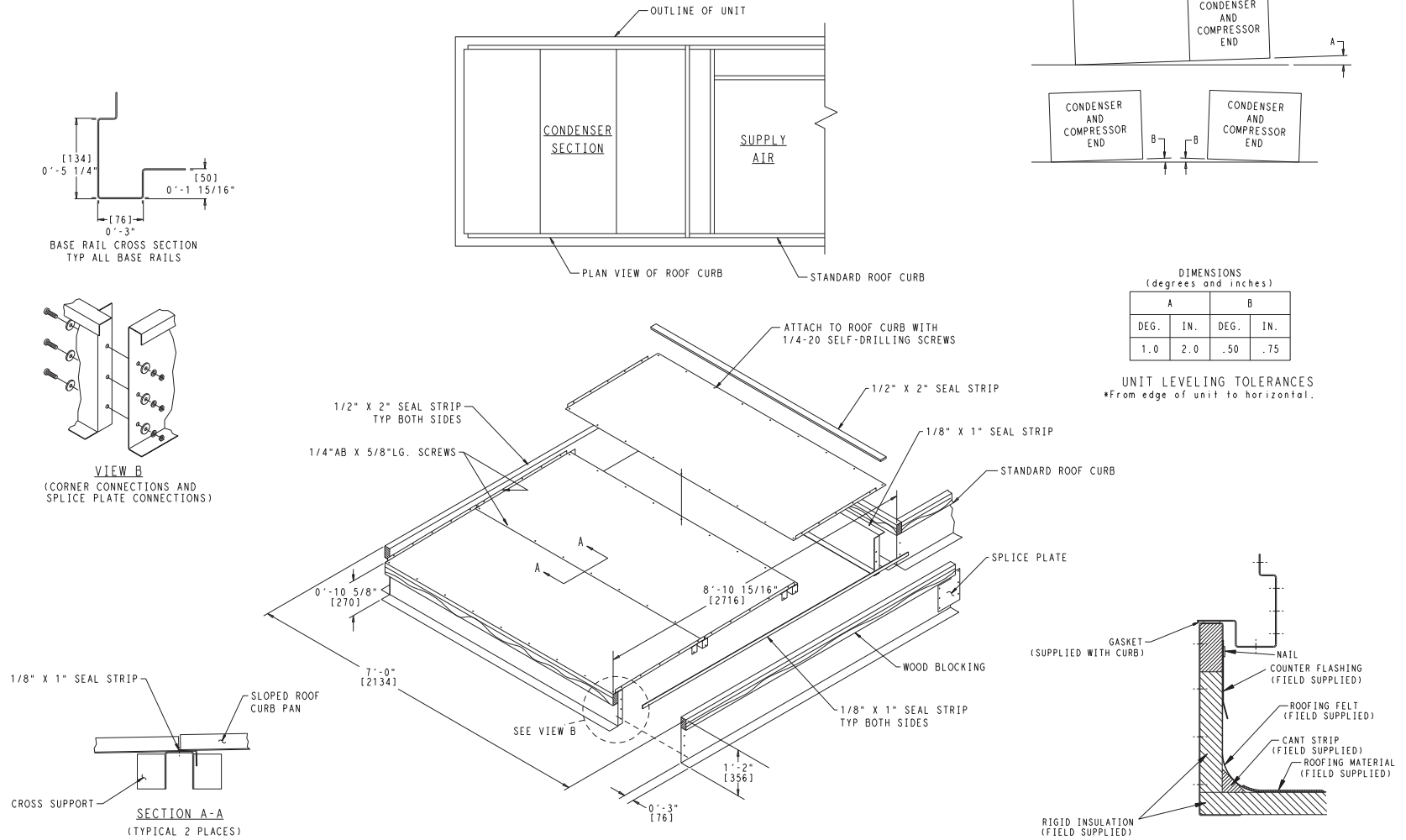

Fig. 8 — Condenser Section Roof Curb Assembly — CRRFCURB070A00 (Sizes 70 and 75)

- NOTES:
1. ROOF CURB ACCESSORY CRRFCURB071A00 IS SHIPPED DISASSEMBLED.
  2. DIMENSIONS IN [ ] ARE MILLIMETERS.
  3. ROOF CURB: 14 GA. [VA03-56] STL.  
ROOF CURB PANS: 16 GA. [VA03-56] STL.

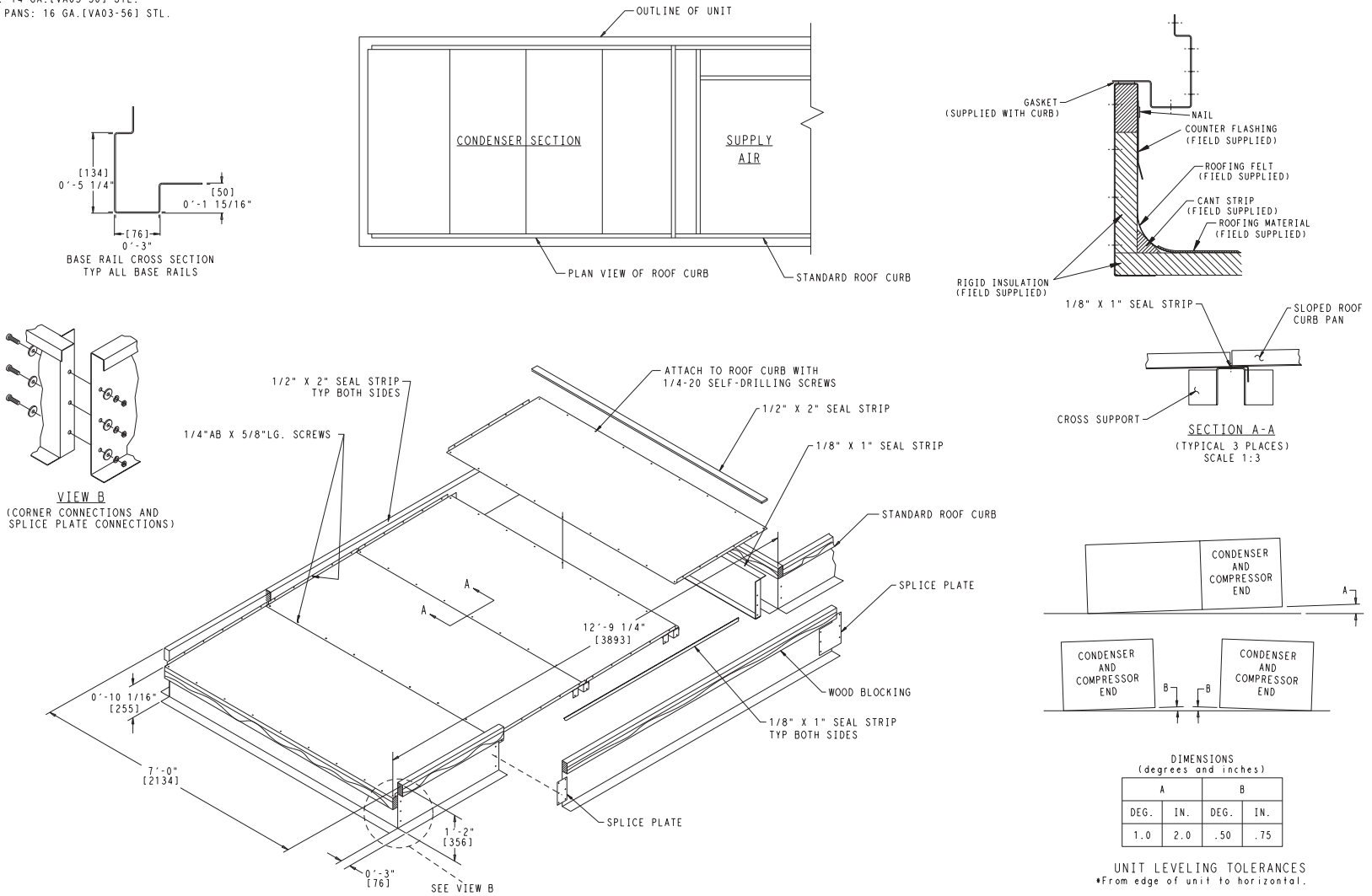
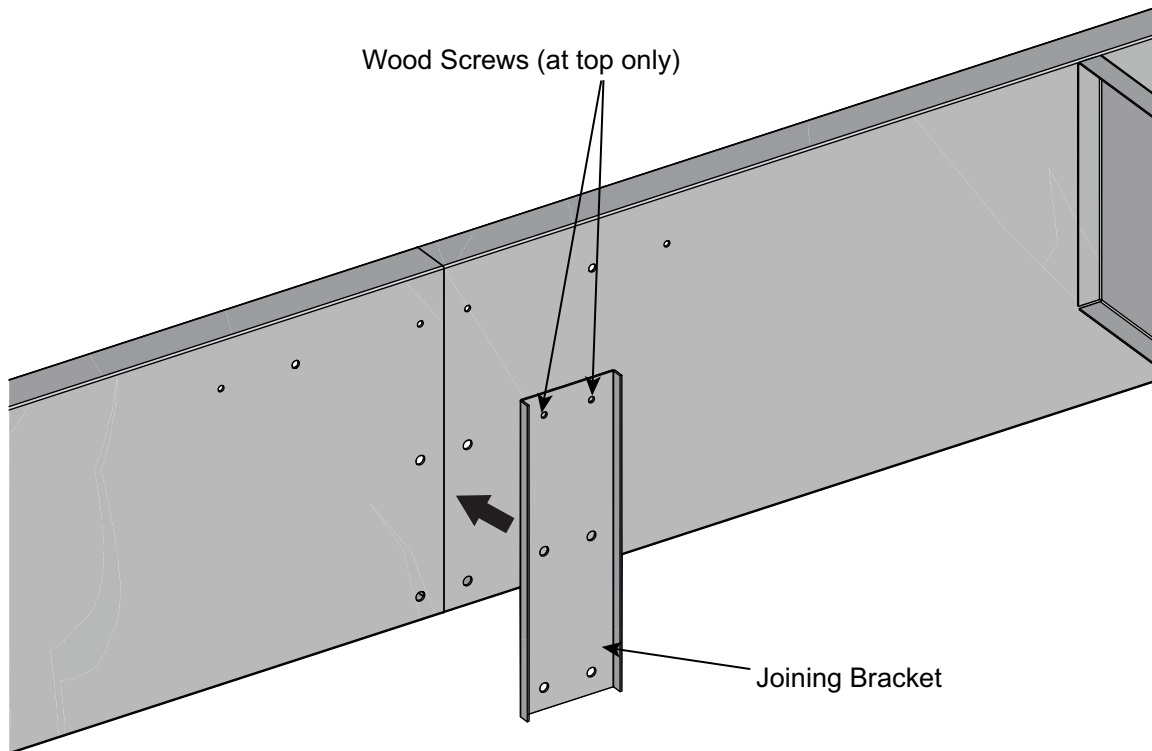
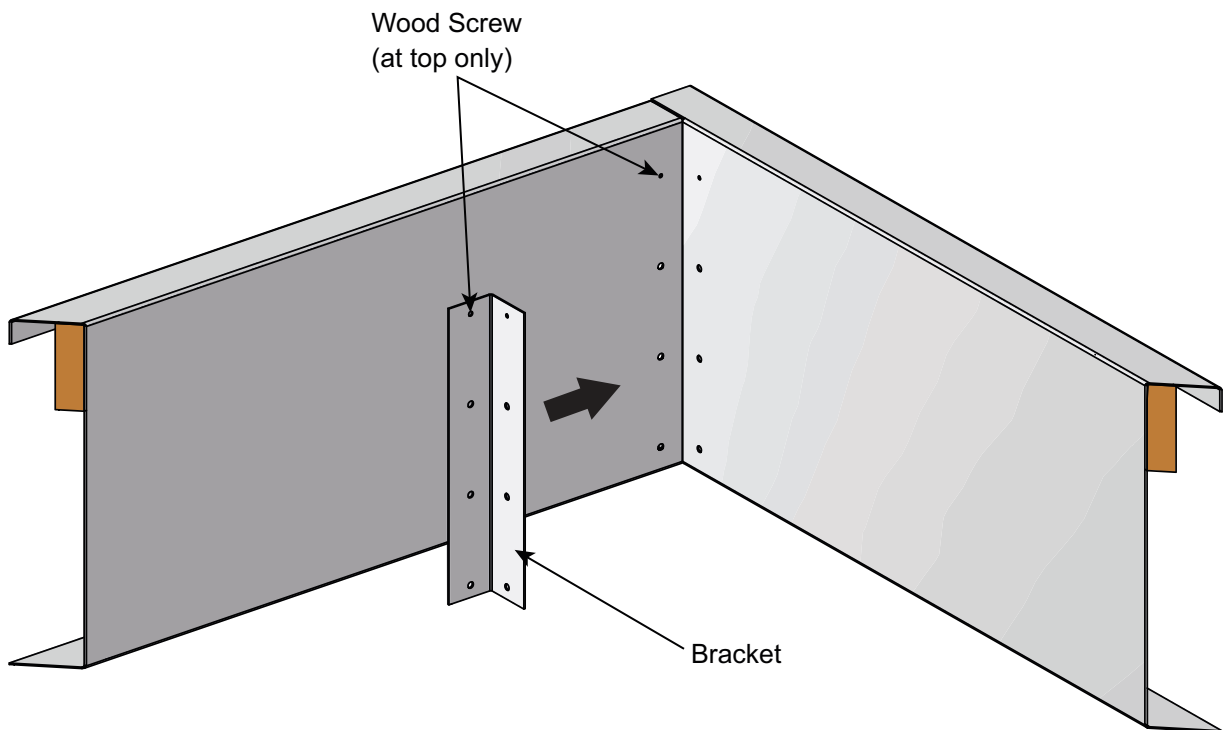

Fig. 9 — Condenser Section Roof Curb Assembly — CRRFCURB071A00 (Sizes 90 and 100)



**Fig. 10 – Joining Bracket**



**Fig. 11 – Corner Bracket (Side and Ends)**

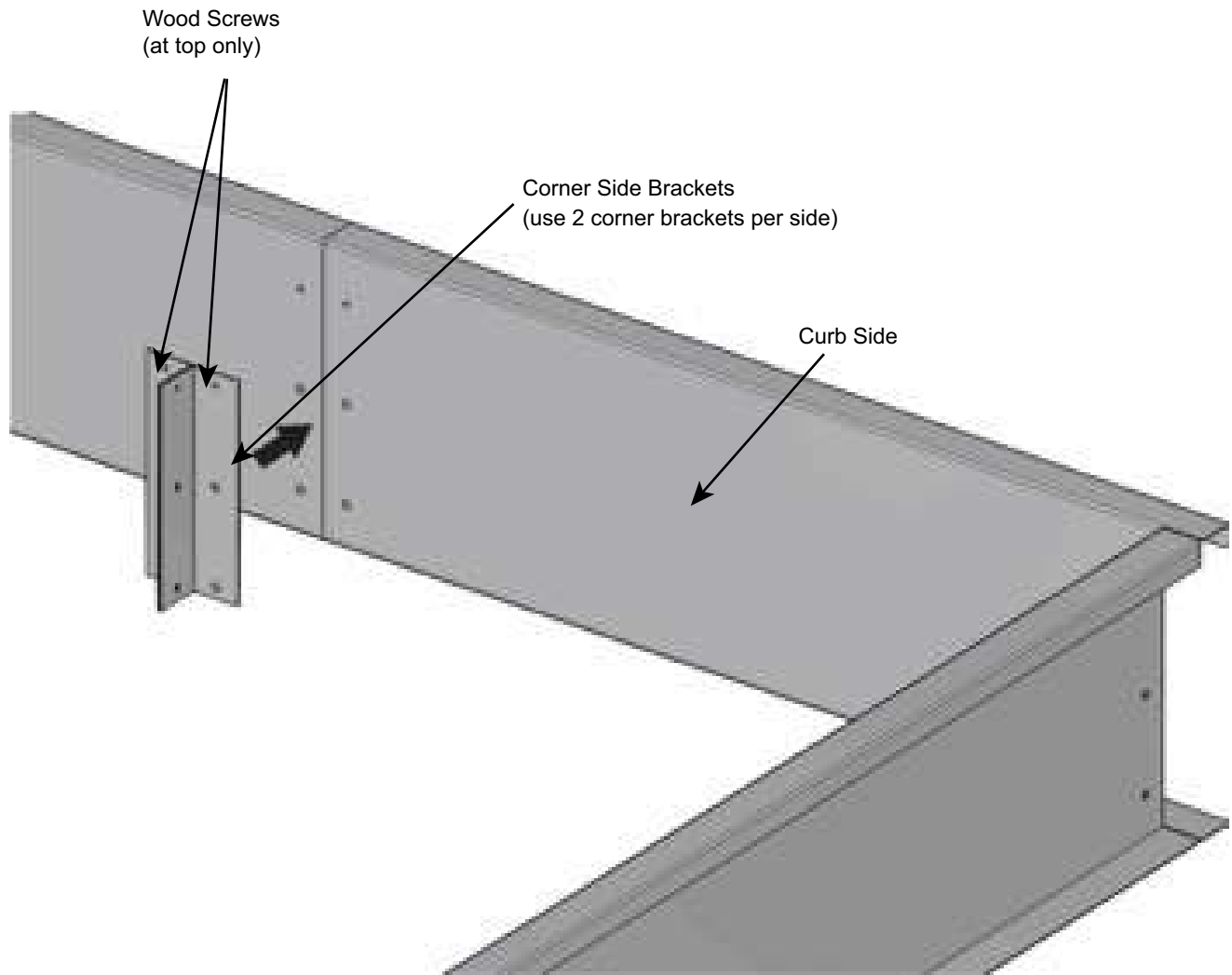

**Fig. 12 — 90 Degrees Joining Bracket**

## Attaching the Ductwork

Ductwork must be installed prior to the placement of the Rooftop Unit (RTU) on the roof curb. It is essential to verify that the position of the curb on the roof support does not interfere with the necessary clearance for both the supply and return ductwork. The ductwork should be connected to the existing roof curb, not directly to the Rooftop Unit (RTU), shown in Fig. 13.

## Flashing the Curb

The roof curb and unit must be sealed completely to prevent any water or air leakages.

## GASKET

The gasket material is factory provided to seal the area between the top flange of the roof curb and the rooftop unit. See “Apply the Gasket Material” on page 17 for more detailed instruction.

## RIGID INSULATION

Rigid insulation is field provided and installed, and offers thermal protection preventing moisture from forming on the inside of the curb, and sound attenuation.

## CANT STRIP

Must be field provided. The cant strip prevents the roofing material from being forced into a ninety-degree angle where the roof surface joins the perpendicular wall of the knockdown curb, avoiding a sharp bend in the roofing material. It additionally aids in roof drainage by providing a slope to prevent ponding water.

## COUNTERFLASHING

The formed metal secured to the top of the curb is field provided and used to cover and protect the upper edge of a base flashing, fasteners, and to prevent moisture entry.

All knockdown curbs are furnished with a full perimeter wood nailer. This wood strip allows the roofer to nail the roofing material up to the top of the curb when sealing the roof. Insulate the outside of the curb using rigid insulation between the roof material and the roof curb.

Insert the top edge of the roofing and flashing material between wood nailer strip and roof curb flange. Nail material to wood nailer on roof curb as required. See Fig. 14 on page 16 for curb flashing example.

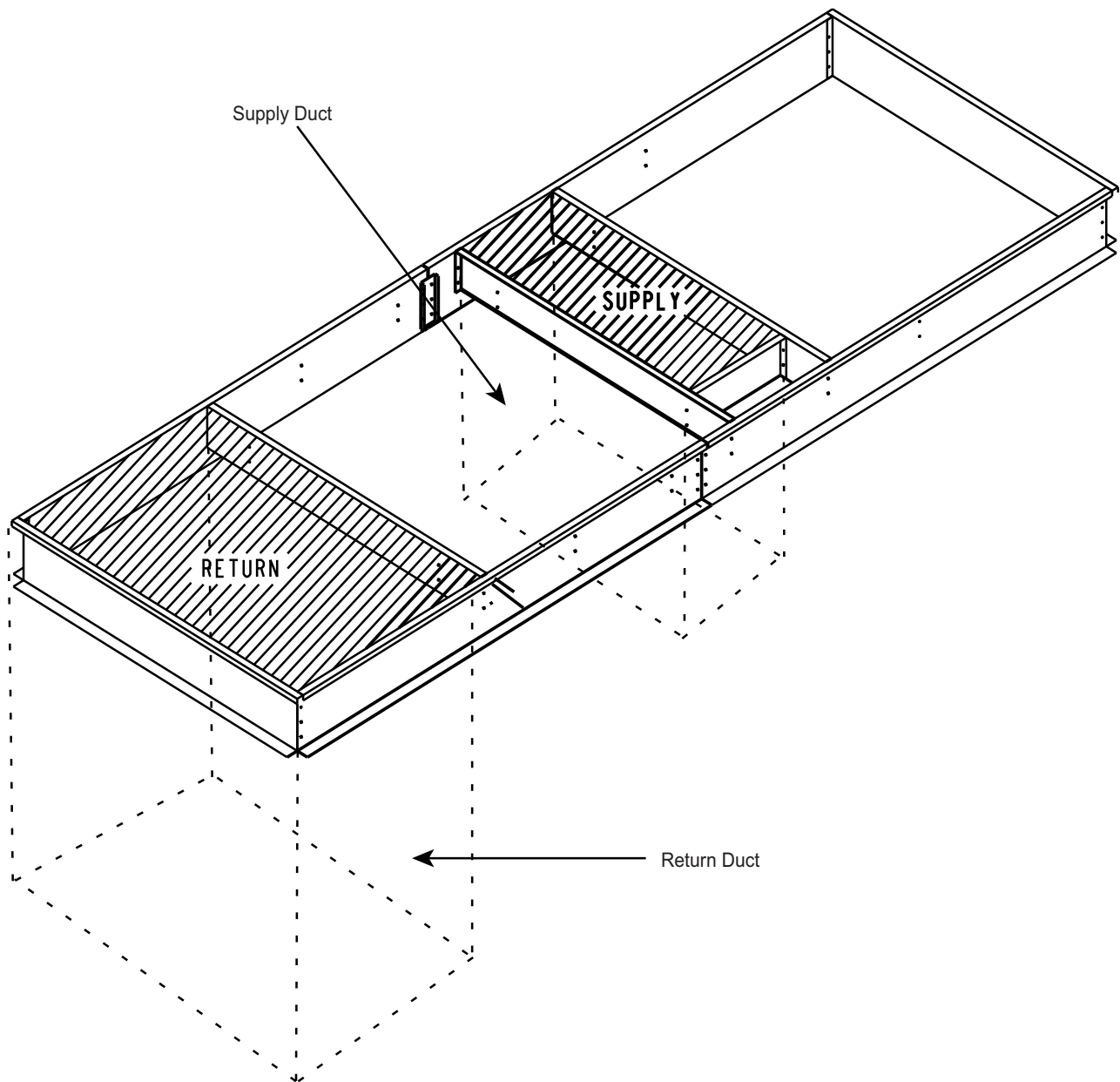
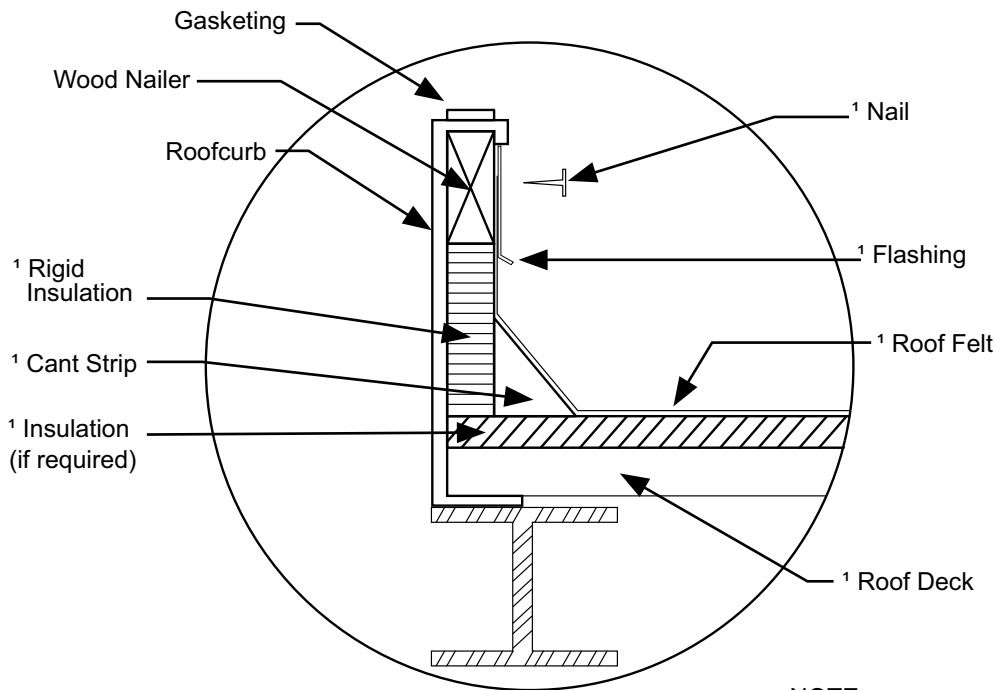
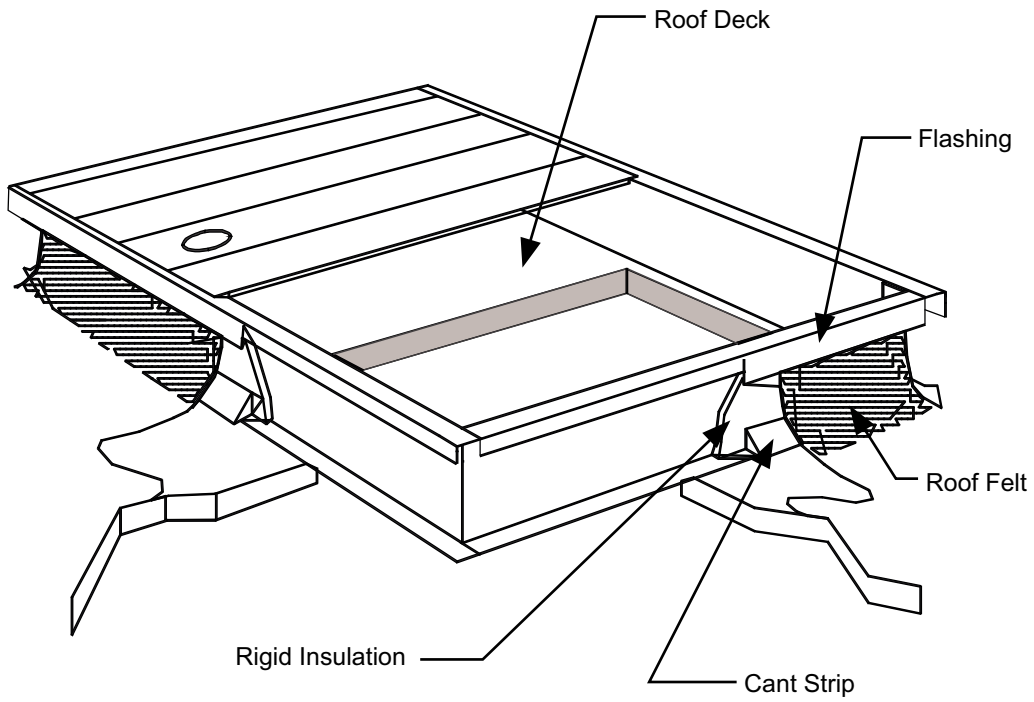

Fig. 13 — Attaching Ductwork



NOTE:  
1. Field Provided

**Detail View**



**Fig. 14 – Curb Flashing Example**

## Apply the Gasket Material

**IMPORTANT:** To prevent property damage or personal injury, it is the installer's responsibility to ensure that the roof curb and unit are properly sealed, effectively preventing any water or air leakage or potential damage.

**IT IS CRITICAL TO MAINTAIN A WATER AND AIR TIGHT SEAL. IMPROPERLY INSTALLED GASKET CAN RESULT IN AIR LEAKS, WATER PENETRATION, AND POOR UNIT PERFORMANCE.**

1. Install sealing gasket on top of the curb perimeter flanges and duct supports. See Fig. 15 for gasket example and materials needed for sealing.
2. Clean the top surface thoroughly to remove dirt or contaminants that could affect the gasket placement.

**IMPORTANT:** Handle the gasket with caution; under extreme hot or cold conditions, it cannot be lifted or repositioned without risk of tearing.

3. Lay out, measure, and cut the gasket as needed.
4. Remove the adhesive paper backing and apply the gasket to the curb.
5. Join the gasket strips together at the corners, ensuring a tight fit with no gaps to prevent leakage. The weight of the unit will compress the gasket, creating a seal between the unit and the roof curb.
6. Avoid sliding the unit into position while it is resting on the curb, as this may damage the gasket material and lead to leaks.

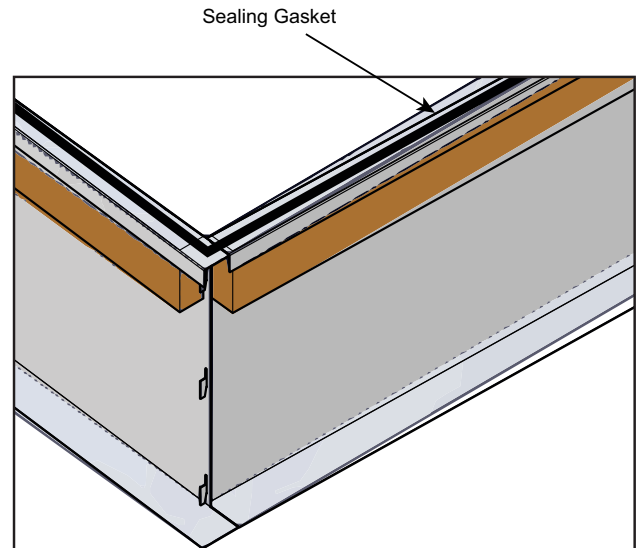

**Sealing gasket on roof curb**



**Gasket Material**

**Fig. 15 – Curb Gasket Example**





