

Casambi BLE to DALI Ceiling Mounted AC PIR Sensor with 10A Relay



Important: Read All Instructions Prior to Installation

Function introduction

L (Input) : Black, 18 AWG ; N (Input) : White, 18 AWG
 L1(Output) : Red, 18 AWG
 DA (Output) : Blue, 22 AWG DA (Yellow) : Pink, 22 AWG

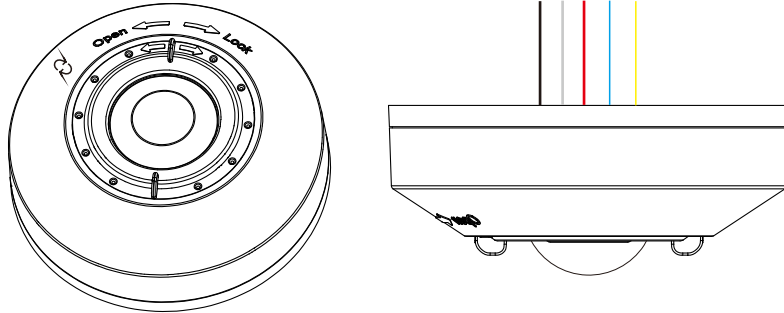

Product Description

The ceiling mounted sensor combines presence sensing, daylight harvesting, DALI dimming and Casambi radio technology. The sensor can work with DALI LED drivers or luminaires, the luminaires just need to be connected to mains power. The result is increased occupant comfort and significant energy savings that meet the most demanding building energy codes. The sensor is suitable for low bay applications which need sensor based automation.

Casambi Technology Explained

The Casambi technology provides a mesh network where all the intelligence of the system is replicated in every node and, in such a way, creates a system with no single point of failure. In this kind of fully distributed architecture, any unit can go offline and catch up from others when they return back online.

Wireless Features

- Control a large number of fixtures from any point
- Simple to use UI
- Wide range of functionality – Grouping Luminaires, different lighting situations for different occasions, colour temperature, daylight sensor, occupancy sensor and much more.

Product Data

Input & Output Characteristics

Operating voltage	100-277VAC 50/60Hz
Standby power	<0.5W
Relay	Max. 10A, 100-277V, For general use/resistive load

Mechanical Data

Dimension	φ111.3*70.4mm
Material	Flame-retarant/ABS
Protection Class	Class II

Safety & EMC

EMC standard(EMC)	EN55015, EN61000, EN61547
Safety standard(LVD)	EN60669-1, EN60669-2-1, AS/NZS60669-1/-2-1
RED	En300328, EN301489-1/-17
Certification	ENEC, CE, RED, UL

Wireless Communication

Transceiver Frequency	2.4GHz ISM band
Radio Range	164 feet (50m) in open field
Radio Certification	FCC/IC, CE

Lighting Control

Features	DALI broadcast, Scene control Autonomous sensor-based control, Scheduler control
----------	---

Sensing

Movement detection	Max. 10-12m @3m height
Installation	2-6m, max. 6m

Connectors

Terminal block/Wire size	AC Line: 18AWG, Signal Line: 22AWG
Wire strip length	10mm

Environment

Operating Temperature Range	Ta: -10°C to +50°C
IP rating	IP20

Key Features

- PIR motion detection
- Daylight harvesting
- Works with DALI drivers or luminaires, broadcast control
- Autonomous sensor-based control
- Can be use for indoor applications

Benefits

- Cost-effective solution for energy savings
- Energy code compliance
- Robust mesh network

Warnings

- DO NOT install with power applied to device.
- DO NOT expose the device to moisture.

Applications

- Open offices
- Individual offices
- Conference rooms
- Classrooms
- Retail stores
- Hospitals
- Lobbies

Detection Pattern

Coverage Side View

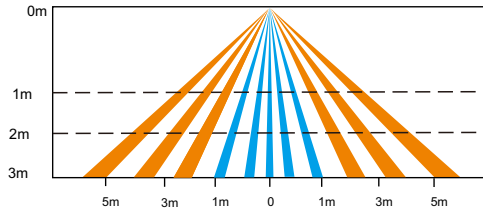

The detection area for movement sensor can be roughly divided into two parts:

- █ Slow movement (person moving < 1.0/s or 0.3m/s)
- █ Quick movement (person moving > 1.3/s or 0.4m/s)

Coverage Top View

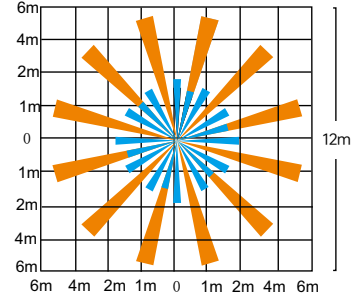

Default sensitivity: 80% ($\phi 9m$ at 3m height)

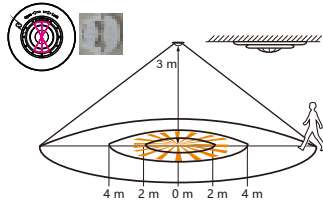

With Corridor Lens Mask:
 $\phi 4-5m$ at 3m height

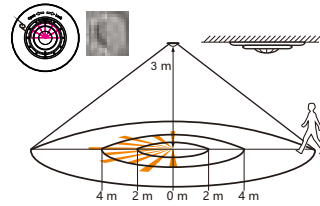

With Semi-Circular Mask:
Half-detection pattern

Detection Area

Note:

- 1) Following different detection areas are based on different installation heights & patterns.
- 2) Detection Pattern is a relevant value, the performance should depends on the site conditions (installation height/ temperature/ sunlight/ humidity/ Blind area...etc)

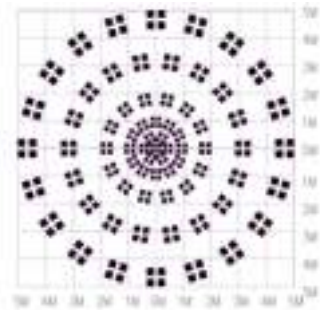

Low-bay lens detection pattern at 3m

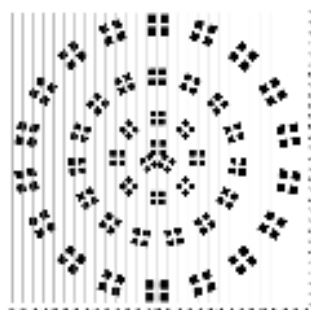

High-bay lens detection pattern at 12m

Place/Detection instruction

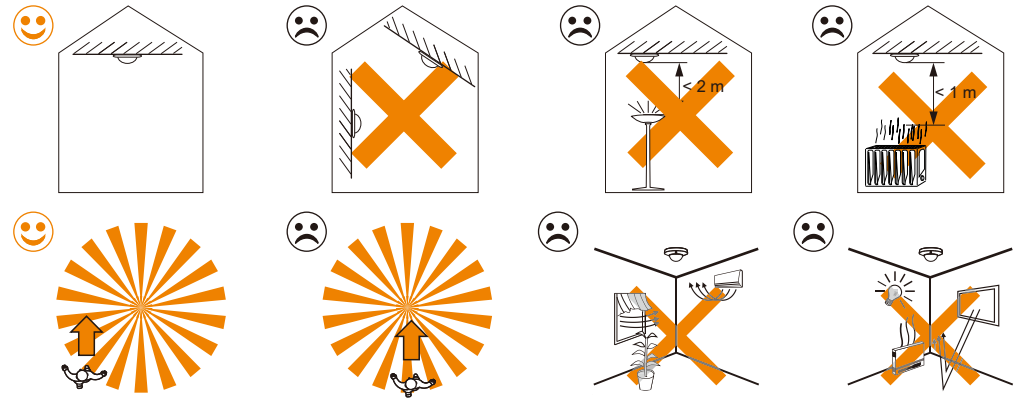

Application

1. Power up the sensor. The load should come on immediately.

2. Vacate the room or remain very still and wait for the load to switch off.

3. Enter the room or make some movement and check that the load switches on.

PRECAUTIONS

- Do not place the SENSOR near heat sources, fans or in ventilated ceiling voids.
- Do not place close to, or positioned such that, any light source points directly into the SENSOR.
- Ensure wires and cables are securely held within the connection terminals.
- Disconnect the SENSOR from the circuit before performing insulation testing of the wiring circuit.

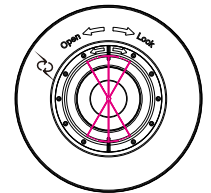

Aisle/Corridor application:
Split the lens cover into aisle type.

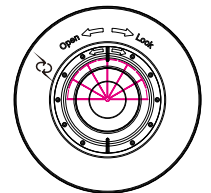

Semi-sphere application:
Split the lens cover into Semi-circle type.

Product Dimension

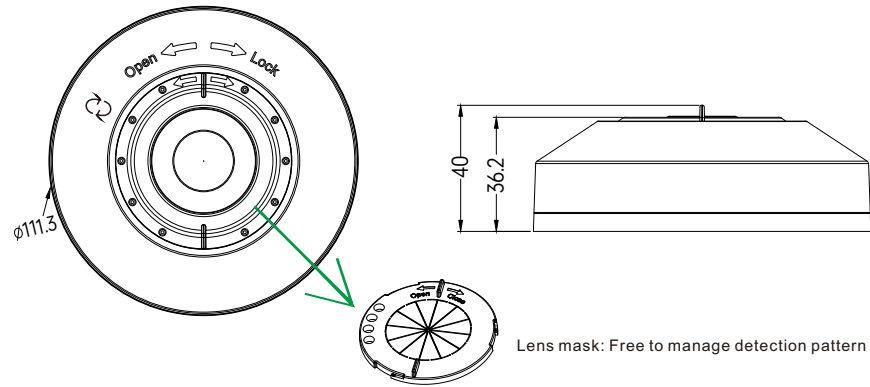

Wiring Diagram

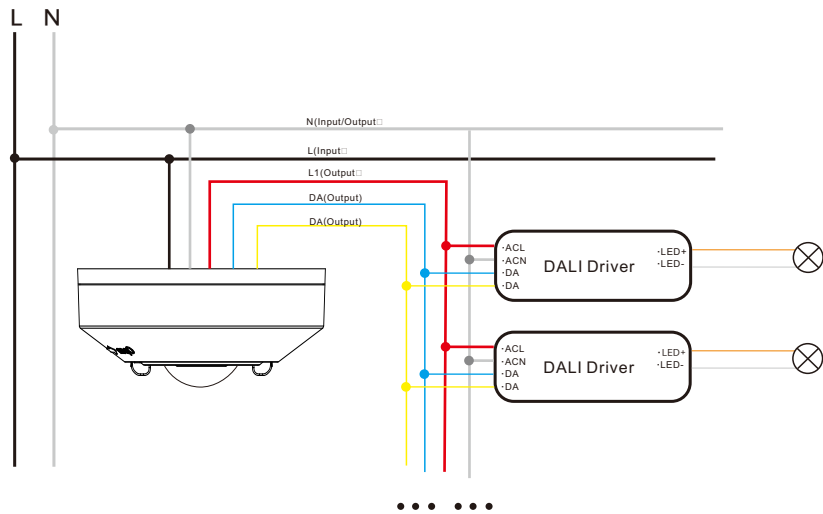

Installation Precautions

- Avoid areas with frequent temperature changes: Keep away from air conditioners, fans, refrigerators, ovens, and other objects that cause rapid temperature changes. The detection effectiveness of PIR motion sensors is closely related to temperature fluctuations, and vents or heat sources can lead to false alarms.
- Avoid areas with significant air flow.
- Avoid facing glass doors and windows directly: 1) Do not face glass doors and windows directly to avoid interference from strong light. 2) Avoid complex environments outside doors and windows, such as direct sunlight, crowds, and moving vehicles.
- Avoid installing opposite large, constantly moving objects: Large objects with significant motion can cause sudden changes in airflow within the detection area, leading to false alarms. Outdoor PIR motion sensors should not be installed opposite large trees or tall bushes.
- Avoid areas with screens, furniture, large potted plants, or other obstacles within the detection range.
- Avoid areas exposed to direct sunlight.