

# CHEFMAN BOILS FASTER™\*

## CUSTOM-TEMP 1.8L KEEP WARM™ KETTLE

### USER GUIDE

- Safety instructions
- Features
- Operating instructions
- Cleaning and maintenance
- Notes
- Terms and conditions
- Warranty registration

RJ11-18-CTI-UK

\*Boils faster than on the hob.

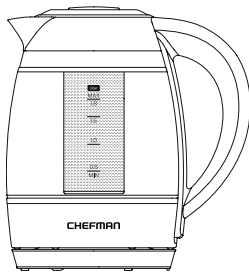



## COOKING FORWARD™

### Welcome!

Whether this is your first Chefman® appliance or you're already a part of our family, we're happy to be in the kitchen with you. The Custom-Temp 1.8L Keep Warm™ Kettle features easy-to-use settings that heat water to the perfect temperature for your drink, whether that's green tea, black tea or even pour-over coffee. The rapid-boil technology means you'll have hot water in mere minutes, and the tricolour LED light ring around the bottom makes it easy to see at a glance whether your water is heating or ready to use. Plus, the bonus tea infuser lets you brew your favourite loose-leaf or bagged teas directly in the kettle.

We know you're excited to start sipping, but please take a few minutes to read our directions, safety instructions and warranty information.

From our kitchen to yours,  
**The Chefman® Team**



### READ ALL INSTRUCTIONS BEFORE USE

For your safety and continued enjoyment of this product, always read the instruction manual before using.



## **CONTENTS**

- 4** Safety instructions
- 9** Features
- 10** Operating instructions
- 15** Cleaning and maintenance
- 17** Notes
- 20** Terms and conditions
- 22** Warranty registration







# SAFETY INSTRUCTIONS

## IMPORTANT SAFEGUARDS

When using electrical appliances, basic safety precautions should always be followed, including:

1. Read all instructions.
  2. Do not touch hot surfaces. Use handles or dials.
  3. To protect against fire, electrical shock and injury to persons, do not immerse the cable, plug, charging base or unit in water or other liquids.
  4. Close supervision is necessary when any appliance is used by or near children.
  5. This appliance can be used by children aged from 8 years and above and persons with reduced physical, sensory or mental capabilities or lack of experience and knowledge if they have been given supervision or instruction concerning use of the appliance in a safe way and understand the hazards involved. Children shall not play with the appliance. Cleaning and user maintenance shall not be made by children unless they are older than 8 and supervised. Keep the appliance and its cord out of reach of children less than 8 years.
- 
- 



# SAFETY INSTRUCTIONS

## IMPORTANT SAFEGUARDS

6. Unplug from the socket when not in use and before cleaning. Allow to cool before putting on or taking off parts, and before cleaning the appliance.
7. Do not operate any appliance with a damaged cable or plug, or after the appliance malfunctions or has been damaged in any manner. If this should occur, contact Chefman® Customer Support for examination, repair or adjustment.
8. The use of accessory attachments not recommended by Chefman® may result in fire, electrical shock or injury to persons.
9. Do not use outdoors.
10. Do not let the cable hang over the edge of a table or worktop or touch hot surfaces.
11. Do not place the unit near or on any type of heat source, such as a gas or electric burner, hob or oven, even if not on. Do not use near an open flame or flammable materials.
12. To disconnect, turn any control to OFF, then remove the plug from the wall socket.





# SAFETY INSTRUCTIONS

## IMPORTANT SAFEGUARDS

13. Misuse of the product can lead to injury. Do not use the appliance for other than its intended use.
14. Scalding may occur if the lid is opened during the heating cycle.
15. Ensure the lid is securely closed before serving any beverages.
16. Do not set a hot container on a wet or cold surface.
17. Do not use a cracked container or a container having a loose or weakened handle.
18. The kettle is only to be used with the base provided.
19. If the kettle is overfilled, boiling water may be ejected.
20. Do not spill water on the connector.
21. Do not touch the base or heating element after use as it may retain residual heat.

**SAVE THESE INSTRUCTIONS  
FOR HOUSEHOLD USE ONLY**





# SAFETY INSTRUCTIONS

## IMPORTANT SAFEGUARDS

**WARNING:** Please ensure that the electrical socket can accommodate the product's standard plug. Do not attempt to alter the plug in any way.

**CAUTION:** To ensure continued protection against risk of electric shock, connect to properly grounded sockets only.



### SHORT CABLE INSTRUCTIONS

A short power-supply cable is provided to reduce the hazards of entanglement or tripping over a longer cable. Longer detachable power-supply cables or extension leads are available and may be used if care is exercised in their use. If a longer detachable power-supply extension lead is used:



1. The marked electrical rating of the extension lead should be at least as great as the electrical rating of the appliance.
  2. If the appliance is of the grounded type, the extension cord should be a grounding-type 3-wire cord; and
  3. The longer cable should be arranged so that it will not drape over the worktop or tabletop where it can be pulled on by children or tripped over.
- 



# SAFETY INSTRUCTIONS

## IMPORTANT SAFEGUARDS

### POWER CABLE SAFETY TIPS

1. Never pull or yank on the cable or the appliance.
  2. To insert the plug, grasp it firmly and guide it into the socket.
  3. To disconnect the appliance, grasp the plug and remove it from the socket.
  4. Never use the product if the power cable shows signs of abrasion or excessive wear. Contact Chefman® Customer Support for additional guidance and support.
  5. Never wrap the cable tightly around the appliance, as this could place undue stress on the cable where it enters the appliance and cause it to fray and break.
- 
- 

**DO NOT OPERATE THE APPLIANCE IF THE POWER CABLE SHOWS ANY DAMAGE OR IF THE APPLIANCE WORKS INTERMITTENTLY OR STOPS WORKING ENTIRELY.**



Do not place the appliance on a hob or any other heatable surface, even if the hob is not on. Doing so is a fire hazard.

## FEATURES

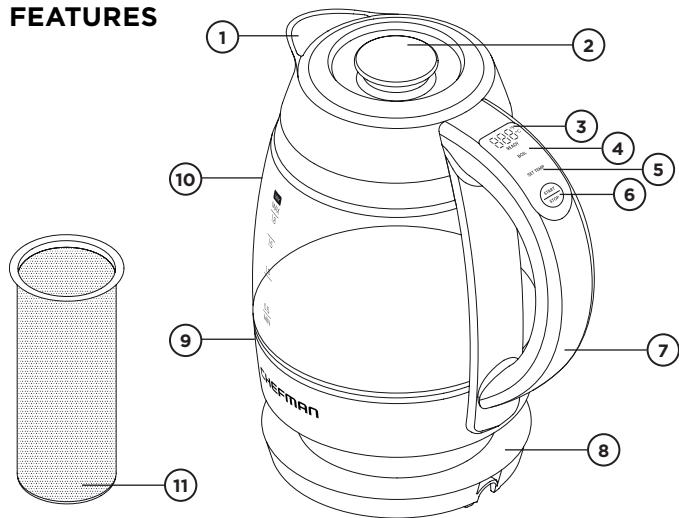

1. Drip-free spout (with filter)
2. Removable lid
3. Temperature display
4. BOIL button
5. SET TEMP button
6. START/STOP button
7. Stay-cool handle
8. 360° swivel power base
9. Tricolour LED indicator lights
10. Borosilicate glass kettle (with water-level markings)
11. Tea infuser (attaches to lid)



## OPERATING INSTRUCTIONS

### BEFORE FIRST USE

To rinse the pot of any packing debris, “brew” a pot of plain water without tea. To do so, follow the directions below.

1. Remove all packing materials. Be sure that all parts are included before discarding any packaging.
2. Pull out the power cable from the compartment under the base, and place the base on a flat surface. (Make sure the power cable comes out of the opening in the base so the unit can sit level.)
3. To rinse the pot of any manufacturing residue, “brew” a pot of plain water without tea. To do so, lift off the lid and fill the kettle with water to the MAX line.
4. Put the lid with the infuser attached (but empty) back on the kettle. Place the kettle on the base unit, and plug it into a power socket.
5. Bring the water to the boil by pressing the BOIL button and then the START/STOP button. The red LED lights inside the kettle will illuminate to indicate the water is heating.
6. Once the kettle boils, empty it (discarding the water), then rinse it with fresh water.





## OPERATING INSTRUCTIONS

### HOW TO MAKE TEA WITH THE TEA INFUSER

1. Place the base on a flat surface.
2. Remove the lid. Remove the infuser from the lid by twisting it and sliding it in the direction indicated on the lid.
3. Fill the kettle to at least the MIN line (0.5 litres) and not above the MAX line (1.8 litres) with cold, fresh water, and place the kettle securely onto its base. Return just the lid to the pot.
4. Plug in the unit. The kettle will beep once and the LED ring near the kettle's base will light up in white, meaning it's in Standby mode.
5. After 2 seconds, the default temperature of 100°C will display on the screen (after first use, the kettle will default to your previously used temperature). To choose a different temperature, press the SET TEMP button repeatedly to toggle through the available choices (see table on p. 13). You can also press the BOIL button to quickly jump to 100°C (full boil). To switch between Celsius and Fahrenheit, press and hold the SET TEMP button for 3 seconds.





## OPERATING INSTRUCTIONS

- When your desired temperature displays on the screen, press START/STOP to begin heating. The LED ring at the base will turn red to indicate it's heating. During heating, the water's current temperature will display on the screen.
- Meanwhile, add tea to the infuser. Use loose tea (about 2 teaspoons per cup) or tea bags based on the amount of water you're heating. (Wait to insert the infuser until the desired temperature has been reached.)
- When the kettle reaches the desired temperature, the kettle will beep three times, READY will display in green on the panel and the LED ring at the kettle's base will turn green. Carefully lift off the kettle lid. Slide the tea-filled infuser onto the underside of the lid (a slight twist helps), insert it into the kettle and press the lid to close.
- Let tea steep according to directions or as you like. When finished steeping, carefully remove the infuser by lifting off the lid. If you would like to return the lid to the kettle, let the infuser cool (you can run it under water), then carefully twist/pull it off, and return the lid (without the infuser) to the kettle; press to close.





## OPERATING INSTRUCTIONS

### BREWING TEMPERATURE GUIDE

The chart below is intended as a starting point for brewing your perfect cup of tea. You may need to vary the amount of tea and steeping times based on the kind of tea, the size of the leaves and your personal preference. The kettle also heats water to the perfect temperature for pour-over coffee (use a pour-over decanter and filter setup; do not put coffee in the tea infuser).

| Beverage Type | Recommended (°C) |
|---------------|------------------|
| Delicate      | 70-75            |
| Green         | 80               |
| White         | 85               |
| Oolong        | 90               |
| Coffee        | 95               |
| Herbal        | 100              |
| Black         | 100              |





## **OPERATING INSTRUCTIONS**

### **HOW TO HEAT WATER WITHOUT MAKING TEA**

Follow the directions for making tea with the infuser but leave the tea and infuser out of the kettle. Use hot water as desired.

### **BOIL-DRY PROTECTION**

The kettle comes equipped with boil-dry protection. While you should never heat the kettle without water at least to the MIN line (0.5 litres), should the unit go dry or start without water, it will automatically shut off completely to avoid damaging the heating element. It will not come back on, even if you replace it on the base, until it has cooled down.

### **AUTOMATIC KEEP WARM FUNCTION**

As soon as the kettle comes to the boil, its LED lights switch from red to green, indicating that it is in Keep Warm mode. The kettle will keep your water or tea hot for up to 1 hour. Lifting the kettle from its base will turn the Keep Warm function off.

### **MUTE FUNCTION**

To mute the kettle's beeps, press and hold the BOIL button for 3 seconds. To turn the sound back on, simply press and hold the same button again for 3 seconds.





## CLEANING AND MAINTENANCE

1. Unplug the kettle and allow it to cool completely before cleaning.
2. Clean the interior of the kettle as needed by removing the infuser and carefully washing the inside with soapy water. Rinse the inside of the kettle thoroughly. Wipe the outside of the kettle and power base with a damp cloth. **WARNING:** Never immerse the kettle or power base in water or wash in the dishwasher; doing so will damage the unit.
3. To clean the spout filter, rinse it under hot water while gently rubbing it with a clean cloth or brush. Do not remove the filter from the spout.
4. Wash the tea infuser in warm, soapy water and rinse thoroughly; the infuser is not dishwasher safe.



### GENERAL CLEANING NOTE

Reheating tea in your kettle may result in a bronze-coloured tea stain on the kettle. This is caused by tea residue that adheres when reheated at high temperatures. To avoid tea-staining, do not reheat the same pot of tea twice, and always rinse the inside of your kettle before each brew. To remove the bronze-coloured staining, add a small amount of food-grade white vinegar to a fresh kettle full of water and boil. After boiling, allow the kettle to cool, discard the water and thoroughly wash and dry the kettle before your next use.





## CLEANING AND MAINTENANCE

### DECALCIFYING

Due to minerals in water, deposits may form on the base of the kettle and cause discolouration. To get the best performance from your kettle, decalcify it from time to time. Frequency will depend on the hardness of your water and how often you use the kettle. You can either use a commercial descaler (following the package directions) or use vinegar and water, and follow the directions below:

1. Fill the kettle with enough white vinegar to cover the bottom by about 1.5 cm. Heat the vinegar to the boil.
2. Repeat this process with fresh vinegar until all deposits are removed.
3. When the descaling process is complete, empty the kettle and rinse it out several times with clean water.











## **TERMS AND CONDITIONS**

### **Limited Warranty**

RJ Brands, LLC d/b/a Chefman® offers a limited 2-year Warranty (the “Warranty”) available on sales through authorised distributors and retailers only. Please note that this Warranty becomes valid from the date of initial retail purchase and that the Warranty is non-transferable and applies only to the original purchaser.

This Warranty is void without proof of purchase within the United Kingdom, the Republic of Ireland, Channel Islands or Isle of Man. Please be aware that this Warranty supersedes all other warranties and constitutes the entire agreement between the consumer and Chefman®. Any changes to the Terms and Conditions of this Warranty must be in writing, signed by a representative of Chefman®. No other party has the right or ability to alter or change the Terms and Conditions of this Warranty.

We may ask you to please submit, via email, photos and/or video of the issue you are experiencing. This is to help us better assess the matter and possibly offer a quick fix. Photos and/or video may also be required to determine Warranty eligibility.

We encourage you to register your product. Registering can make the Warranty process easier and can keep you informed of any updates or recalls on your product. To register, follow the directions on the Chefman® Warranty Registration page in the Chefman® User Guide. Please retain your proof of purchase even after registering. In the event that you do not have proof of your purchase date, we may declare your Warranty void or we may, at our sole discretion, apply the date of manufacture as the purchase date for purposes of this Warranty.





## TERMS AND CONDITIONS

### Limited Warranty

#### WHAT THE WARRANTY COVERS

- **Manufacturer defects** - Chefman® products are warranted against defects in material and workmanship, under normal household use, for a period of 2 years from the date of purchase when used in accordance with the directions listed in the Chefman® User Guide. If your product does not work as it should, please contact Customer Support at [support@chefman.co.uk](mailto:support@chefman.co.uk) so that we may assist you.

#### THIS WARRANTY DOES NOT COVER

- **Misuse** - Damage that occurs from neglectful or improper use of products, including, but not limited to, damage that occurs as a result of usage with incompatible voltage, regardless of whether the product was used with a converter or adapter. See Safety Instructions in the Chefman® User Guide for information on proper use of product;
  - **Poor Maintenance** - General lack of proper care. We encourage you to take care of your Chefman® products so that you may continue to enjoy them. Please see Cleaning and Maintenance directions in the Chefman® User Guide for information on proper maintenance;
  - **Commercial Use** - Damage that occurs from commercial use;
  - **Normal Wear and Tear** - Damage or degradation expected to occur due to normal use over time;
  - **Altered Products** - Damage that occurs from alterations or modifications by any entity other than Chefman® such as the removal of the rating label affixed to the product;
  - **Catastrophic Events** - Damage that occurs from fire, floods or natural disasters; or
  - **Loss of Interest** - Claims of loss of interest or enjoyment.
- 
- 

## CHEFMAN® WARRANTY REGISTRATION

### What do I need to register my product?



- Contact Information
- Model Number
- Date Code
- Access Code
- Proof of Purchase (online confirmation, receipt, gift receipt)

**NOTE:** Label depicted here is an example.

### How do I register my product?

All you need to do is fill out a simple Chefman® registration form. You can easily access the form in one of the two ways listed below:

1. Visit [Chefman.com/register](https://www.chefman.com/register).
2. Scan the QR code to access site:





## CHEFMAN® WARRANTY REGISTRATION

### For product information

Please visit us at [Chefman.com](http://Chefman.com).

**EXCEPT WHERE SUCH LIABILITY IS REQUIRED BY LAW, THIS WARRANTY DOES NOT COVER, AND CHEFMAN® SHALL NOT BE LIABLE FOR, INCIDENTAL, INDIRECT, SPECIAL, OR CONSEQUENTIAL DAMAGES, INCLUDING WITHOUT LIMITATION, DAMAGE TO, OR LOSS OF USE OF THE PRODUCT, OR LOST SALES OR PROFITS OR DELAY OR FAILURE TO PERFORM THIS WARRANTY OBLIGATION. THE REMEDIES PROVIDED HEREIN ARE THE EXCLUSIVE REMEDIES UNDER THIS WARRANTY, WHETHER BASED ON CONTRACT, TORT OR OTHERWISE.**



Chefman® is a registered trademark of RJ Brands, LLC.  
Chefman Boils Faster™ is a trademark of RJ Brands, LLC.  
Keep Warm™ is a trademark of RJ Brands, LLC.  
Cooking Forward™ is a trademark of RJ Brands, LLC.



Chefman UK Limited  
2nd Floor - Parkgates  
Bury New Road  
Prestwich, Manchester  
United Kingdom M25 0TL



# CHEFMAN.



[CHEFMAN.COM](https://www.chefman.com) | [@MYCHEFMAN](https://www.instagram.com/mychefman)

©CHEFMAN 2024

RJ11-18-CTI-UK\_UG\_FINAL\_OTP\_011124

