

# CHEFMAN®

---

## 1.6-Quart

# FRY GUY

## USER GUIDE

- Safety Instructions
- Features
- Operating Instructions
- Deep Frying Tips
- Frying Chart
- Cleaning and Maintenance
- Notes
- Terms and Conditions
- Warranty Registration

RJ07-15-SS

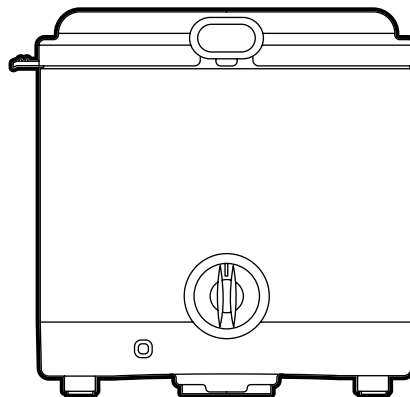

# COOKING FORWARD™

## Welcome!

Whether this is your first Chefman® appliance or you're already a part of our family, we're happy to be in the kitchen with you! With your new Fry Guy deep fryer, you can fry up french fries, doughnuts, chicken wings, and much more to golden perfection. The unit's thermostat makes it easy to adjust the oil's temperature. The fry basket has a cool-touch handle that makes it safe to lift, lower, and drain, while the cover's window allows you to keep an eye on your food. The compact Fry Guy is countertop-friendly and fits easily in any kitchen.

We know you are excited to get frying, but please take a few minutes to read our directions, safety instructions, and warranty information.

From our kitchen to yours,

**The Chefman® Team**



**READ ALL INSTRUCTIONS BEFORE USE**  
For your safety and continued enjoyment of this product, always read the instruction manual before using.

# CONTENTS

- 1** Safety Instructions
- 3** Features
- 4** Operating Instructions
- 6** Deep Frying Tips
- 8** Frying Chart
- 9** Cleaning and Maintenance
- 10** Notes
- 13** Terms and Conditions
- 15** Warranty Registration

# SAFETY INSTRUCTIONS

## IMPORTANT SAFEGUARDS

This appliance is for **HOUSEHOLD USE ONLY**.

**WARNING:** When using electrical appliances, basic safety precautions should always be followed, including:

1. Read all instructions.
2. Do not touch hot surfaces. Use handles or knobs.
3. To protect against electrical shock, do not place the cord, plug, or appliance in water or other liquids.
4. Close supervision is necessary when any appliance is used by or near children.
5. Unplug from the outlet when not in use and before cleaning. Allow to cool before putting on or taking off parts, and before cleaning the appliance.
6. Do not operate any appliance with a damaged cord or plug or after the appliance malfunctions, or has been damaged in any manner. Should this occur, please contact Chefman Customer Support.
7. The use of accessory attachments not recommended by Chefman may cause injuries.
8. Do not use outdoors.
9. Do not let the cord hang over the edge of the table or counter or touch hot surfaces.
10. Do not place on or near a hot gas or electric burner, or in a heated oven.

# SAFETY INSTRUCTIONS

## IMPORTANT SAFEGUARDS

11. Extreme caution must be used when moving an appliance containing hot oil or other hot liquids.
12. Always attach the plug to the appliance first, then plug the cord in the wall outlet. To disconnect, turn any control to “off,” then remove the plug from the wall outlet.
13. Do not use the appliance for other than intended use.
14. Be sure the handle is properly assembled to the basket and locked in place. See detailed assembly instructions.

## SAVE THESE INSTRUCTIONS

### SHORT CORD INSTRUCTIONS

1. A short, detachable power cord is provided to reduce the risk resulting from becoming entangled in or tripping over a longer cord.
2. **WARNING:** Do not use an extension cord with this product. Serious hot oil burns may result from the deep fryer being pulled off a countertop. Do not allow the cord to hang over the edge of the counter where it may be grabbed by children or become entangled with the user.

California Proposition 65:  
(Applicable for California Residents only)



**WARNING:**

Cancer and Reproductive Harm -  
[www.P65Warnings.ca.gov](http://www.P65Warnings.ca.gov).



**Do not place appliance on  
stovetop or other heatable  
surface, even if stovetop is not  
on. Doing so is a fire hazard.**

# FEATURES

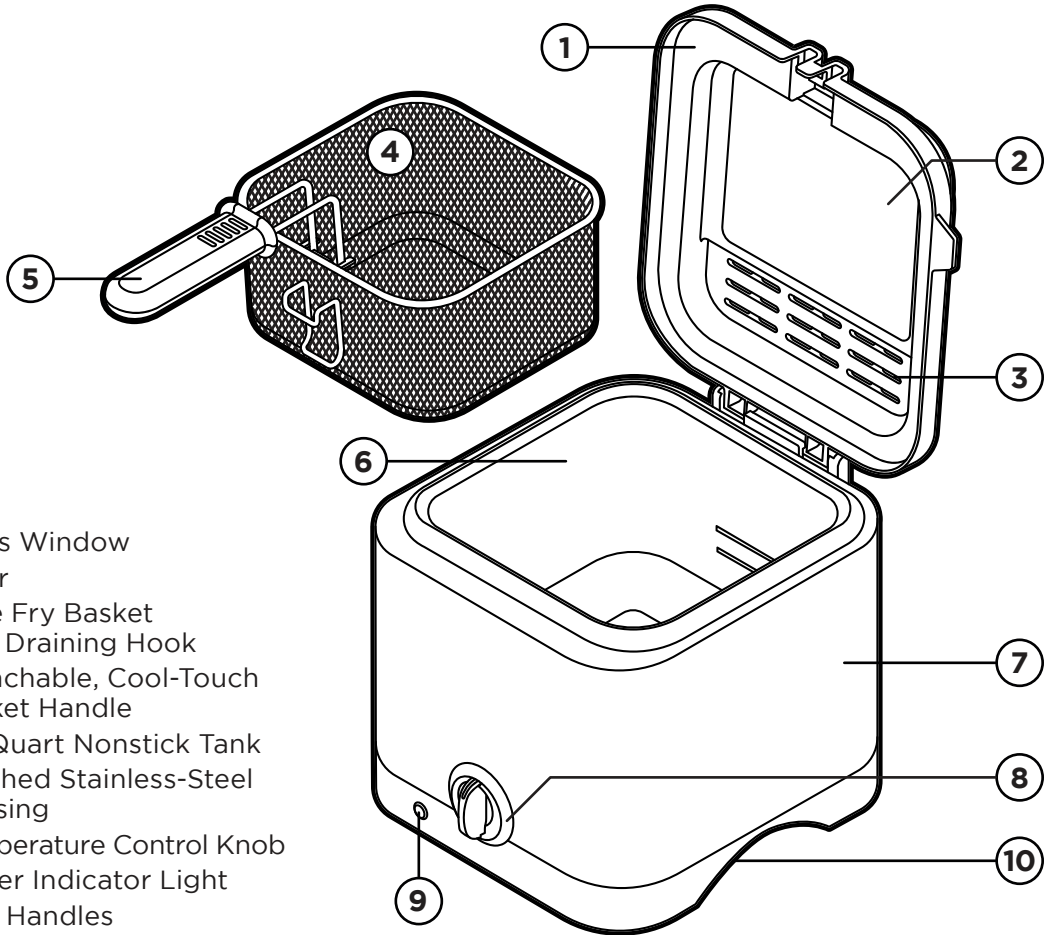

1. Lid
2. Glass Window
3. Filter
4. Wire Fry Basket with Draining Hook
5. Detachable, Cool-Touch Basket Handle
6. 1.6-Quart Nonstick Tank
7. Brushed Stainless-Steel Housing
8. Temperature Control Knob
9. Power Indicator Light
10. Side Handles
11. Magnetic Breakaway Power Cord (not shown)

# OPERATING INSTRUCTIONS

## BEFORE FIRST USE

With hardly any assembly required, you can be frying in no time!

1. Carefully unpack the Fry Guy and all parts. Read and remove all stickers, except for the rating label on the bottom of the unit, which should remain on.
2. Clean the interior and exterior surfaces of the deep fryer with a damp cloth or sponge. Wipe dry with a soft cloth. Never immerse the deep fryer or cord in water or any other liquid.
3. Position the deep fryer on a dry, level, heat-resistant surface. **NOTE:** We recommend using a separate outlet and circuit from other appliances when using the deep fryer to avoid overloading the circuit.

## HOW TO ASSEMBLE THE FRY BASKET HANDLE

For safety reasons, be sure the basket handle is attached securely. The basket handle can remain in place for cleaning and storage or can be removed after each use to store more compactly.

1. Attach the handle to the basket by pressing in on the tabs and inserting into the holes of the basket until it locks into place as illustrated.
2. Check that the handle is securely in place by pulling on it. Both prongs should be in the round holes, and both sides of the handle should be secured by the tabs on the bracket.

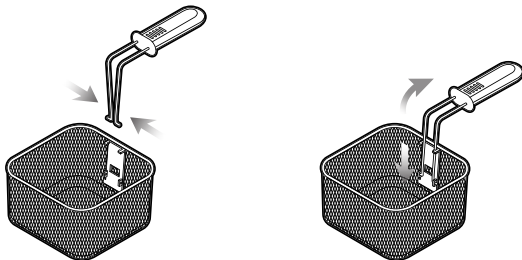

# OPERATING INSTRUCTIONS

## HOW TO USE YOUR DEEP FRYER

Few foods are more satisfying than crisp fried fare, and with your 1.6-Quart Fry Guy, frying is easy to do without a lot of oil or mess. Follow the directions below for best results.

1. **Place your deep fryer** on a clean, dry, level, stable, and heat-resistant surface, away from the countertop edge.
2. **Fill the tank with cooking oil**, ensuring the oil level is between the MIN and MAX fill lines located on the tank. Do not fill past the MAX fill line, and never heat the deep fryer without oil.
3. **Attach the magnetic connector end** of the cord to the back of the unit, then plug the other end of the cord into a 120-volt outlet.
4. **Adjust the temperature control knob** to the desired temperature. The indicator light will turn on. **NOTE:** The oil may be heated with or without the deep fryer lid in the closed position. If the lid is in the closed position, it will prevent possible splattering.
5. **Check that the oil is ready.** The indicator light will turn off when the oil reaches the selected temperature.
6. **Place food to be fried in the wire basket**, then slowly lower the basket into the oil in the tank. **NOTES:** Do not overload the basket as this can cause a boil-over. Overloading will also substantially lower the oil temperature, and the food will absorb more oil, making it greasy. Be aware that high-moisture foods, such as battered ingredients, are more likely to cause a boil-over. Take caution when lowering the basket to make sure the oil does not boil over.
7. **Lower the fryer lid** into the closed position to prevent splatter. (You can view progress through the window.)

# OPERATING INSTRUCTIONS

8. **Fry food** according to your recipe or to desired doneness. **NOTE:** When food is placed in the deep fryer, it will cool the oil, making the indicator light turn back on. This is normal. The fryer will regulate the heat, and the light will turn off when the set temperature is reached.
9. **Remove the basket from the oil.** When your food is done, carefully lift the lid. Raise the basket above the oil by lifting the fryer basket handle. Using the hook, perch the basket above the tank to allow excess oil to drain back in. **CAUTION:** To avoid risk of burns, do not touch any other parts of the fryer when in use or when hot.
10. **Carefully remove the basket from the unit,** remove food from the basket using tongs or a slotted spoon, and serve. **CAUTION:** Food and the basket will be very hot coming out of the hot oil. Do not attempt to remove food from the basket with your hands.
11. **After you are done cooking, turn off and unplug the unit.** Turn the temperature control knob to the left as far as it will go, disconnect the plug from the wall outlet, then remove the cord's magnetic connector from the unit.
12. **Let oil cool completely** (at least 2 hours) before cleaning the unit.

## DEEP FRYING TIPS

Once you get the hang of it, deep frying is easier, and less messy, than pan frying, especially with these handy tips.

### PREP

- **Before deep frying, remove excess moisture** from food by blotting with a paper towel. Moist foods cause excess foaming and splattering. Do not add wet foods to cooking oil. Even small amounts of water may cause oil to splatter.
- **Cut food into similar-sized pieces** so that they cook evenly. Avoid using pieces that are too thick.

# OPERATING INSTRUCTIONS

## OIL

- **Use only good-quality cooking oil** for deep frying. Deep frying foods in butter, margarine, olive oil, or animal fat is not recommended because those fats begin to smoke at a lower temperature.
- **Consider reusing frying oil.** Unless there are many burned food particles, frying oil can generally be used more than once. Strain through a fine-mesh strainer or a double layer of cheesecloth into a clean container with a lid, and store in a cool, dark spot. Depending on what you cook, you can usually use oil about 3 times before it needs to be discarded.
- **Do not pour oil down the drain,** where it can clog pipes and pollute waterways. Dispose of it in a sealed container in the garbage. Depending on where you live, you may also be able to take cooking oil to a recycling facility.

## FRYING

- **Avoid overfilling the basket.** Putting too much food in the fryer at one time will lower the oil temperature excessively, causing your food to absorb more oil and become greasy.
- **Have a landing spot ready** for your fried food where excess oil can drain off. Good choices include a paper towel-lined plate or a wire cooling rack set in a rimmed baking sheet.
- **For best flavor, salt foods immediately** after they come out of the fryer.
- **Serve deep-fried foods hot or warm.** If you need to fry food in batches, you can keep the first batches warm by placing them on a wire rack set in a rimmed baking sheet, then in an oven preheated to 200°F while subsequent batches cook.
- **Use caution when deep frying tortillas.** Flour tortillas contain air bubbles. During deep frying, oil can become trapped within these bubbles. If not properly drained, the bubbles can burst and cause burns. Therefore, after deep frying tortillas, carefully raise them out of the cooking oil, and allow oil to drain from the tortillas for approximately 30 seconds.

# FRYING CHART

Use this chart as a guide for deep frying some popular foods. Always follow current food safety guidelines when checking for doneness.

<b>Food</b>	<b>Amount</b>	<b>Temperature (°F)</b>	<b>Cooking Time (mins)</b>
Chicken Wings	8 wings	375	8-9
Doughnuts	1 doughnut	375	2-4 (flip once)
Fish Sticks	4 sticks	375	4
Frozen Egg Rolls/ Taquitos	5 pieces	360	5
Onion Rings	5 oz	375	3
Frozen French Fries	10 oz	350	8-9

# CLEANING AND MAINTENANCE

This appliance requires little maintenance. It contains no user serviceable parts. Do not try to repair it yourself. If the unit needs repairs, please contact Chefman Customer Support.

1. Before cleaning, unplug from the outlet, detach the cord from the unit, and allow the oil and unit to cool completely. (The oil can take at least 2 hours to cool.) Do not attempt to move the deep fryer while it is still hot.
2. After the unit and oil have cooled completely, detach the lid by grasping both sides firmly and pulling up from the unit. Empty the unit of the cooking oil (see tip on p. 7 for reusing the oil, if appropriate).
3. Using a soft sponge or cloth, wash the unit tank, lid, and fry basket with warm water and mild detergent, rinse, and dry thoroughly. **CAUTION:** Never immerse the deep fryer or cord in water or any other liquid. Do not place in the dishwasher. Never use abrasive cleaners or scouring pads to clean the deep fryer, as those may damage the surfaces.
4. The fry basket is top-rack dishwasher-safe. Remove the handle before putting the basket in dishwasher. The lid may also be washed in the top rack of the dishwasher.
5. Be sure all parts are clean and dry before storing. Store the appliance in its box or in a clean, dry place. Never store it while it is hot or wet. Never wrap the cord tightly around the appliance; keep it loosely coiled.







# TERMS AND CONDITIONS

## Limited Warranty

RJ Brands, LLC d/b/a Chefman® offers a limited 1-year Warranty (the “Warranty”) available on sales through authorized distributors and retailers only. Please note that this Warranty becomes valid from the date of initial retail purchase and that the Warranty is non-transferable and applies only to the original purchaser.

This Warranty is void without proof of purchase within the United States and Canada. Please be aware that this Warranty supersedes all other warranties and constitutes the entire agreement between the consumer and Chefman®. Any changes to the Terms and Conditions of this Warranty must be in writing, signed by a representative of Chefman®. No other party has the right or ability to alter or change the Terms and Conditions of this Warranty.

We may ask you to please submit, via email, photos and/or video of the issue you are experiencing. This is to help us better assess the matter and possibly offer a quick fix. Photos and/or video may also be required to determine warranty eligibility.

We encourage you to register your product. Registering can make the Warranty process easier and can keep you informed of any updates or recalls on your product. To register, follow the directions on the Chefman® Warranty Registration page in the Chefman® User Guide. Please retain your proof of purchase even after registering. In the event that you do not have proof of your purchase date, we may declare your Warranty void or we may, at our sole discretion, apply the date of manufacture as the purchase date for purposes of this Warranty.

# TERMS AND CONDITIONS

## Limited Warranty

### WHAT THE WARRANTY COVERS

- **Manufacturer Defects** – Chefman® products are warranted against defects in material and workmanship, under normal household use, for a period of 1 year from the date of purchase when used in accordance with the directions listed in the Chefman® User Guide. If your product does not work as it should, please contact Customer Support at support@chefman.com so that we may assist you.

### THIS WARRANTY DOES NOT COVER

- **Misuse** – Damage that occurs from neglectful or improper use of products, including, but not limited to, damage that occurs as a result of usage with incompatible voltage, regardless of whether the product was used with a converter or adapter. See Safety Instructions in the Chefman® User Guide for information on proper use of product;
- **Poor Maintenance** – General lack of proper care. We encourage you to take care of your Chefman® products so that you may continue to enjoy them. Please see Cleaning and Maintenance directions in the Chefman® User Guide for information on proper maintenance;
- **Commercial Use** – Damage that occurs from commercial use;
- **Normal Wear and Tear** – Damage or degradation expected to occur due to normal use over time;
- **Altered Products** – Damage that occurs from alterations or modifications by any entity other than Chefman® such as the removal of the rating label affixed to the product;
- **Catastrophic Events** – Damage that occurs from fire, floods, or natural disasters; or
- **Loss of Interest** – Claims of loss of interest or enjoyment.

# CHEFMAN® WARRANTY REGISTRATION

## What do I need to register my product?

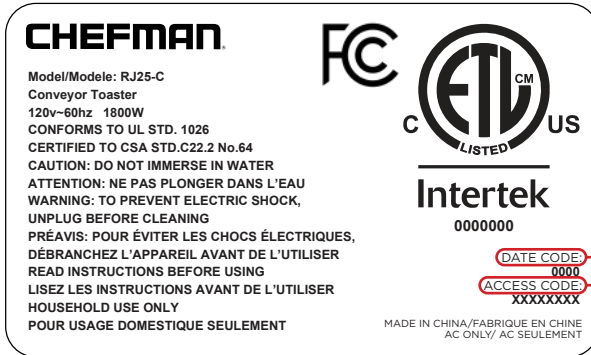

- Contact Information
- Model Number
- Proof of Purchase (online confirmation, receipt, gift receipt)
- Date Code
- Access Code

**NOTE:** Label depicted here is an example.

## How do I register my product?

All you need to do is fill out a simple Chefman® registration form. You can easily access the form in one of the two ways listed below:

1. Visit [chefman.com/register](http://chefman.com/register).
2. Scan the QR code to the right to access site:



# CHEFMAN® WARRANTY REGISTRATION

**For product information,** visit [chefman.com](http://chefman.com)

EXCEPT WHERE SUCH LIABILITY IS REQUIRED BY LAW, THIS WARRANTY DOES NOT COVER, AND CHEFMAN® SHALL NOT BE LIABLE FOR, INCIDENTAL, INDIRECT, SPECIAL, OR CONSEQUENTIAL DAMAGES, INCLUDING WITHOUT LIMITATION, DAMAGE TO, OR LOSS OF USE OF THE PRODUCT, OR LOST SALES OR PROFITS OR DELAY OR FAILURE TO PERFORM THIS WARRANTY OBLIGATION. THE REMEDIES PROVIDED HEREIN ARE THE EXCLUSIVE REMEDIES UNDER THIS WARRANTY, WHETHER BASED ON CONTRACT, TORT OR OTHERWISE.

Chefman® is a registered trademark of RJ BRANDS, LLC.

Cooking Forward™ is a trademark of RJ Brands, LLC.

Intertek® is a registered trademark of Intertek Group, PLC.

# CHEFMAN®

@mychefman



[www.chefman.com](http://www.chefman.com)

---

©CHEFMAN 2021