

Fit™ Mobile Cart FOR INTERACTIVE DISPLAYS

Easy Five-Step Installation

Quick Setup Guide

For complete installation instructions, refer to the Installation Manual included with this product.

This Quick Setup Guide is meant to provide only an overview of the various installation steps.

ALWAYS read the Installation Instructions in its entirety before beginning the Installation.

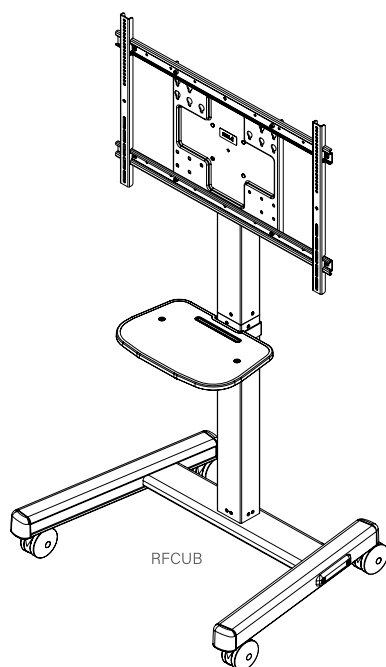

STEP 01

Assemble The Base

Assemble the right leg assembly (I) and left leg assembly (N) to the crossbar (L) using two 5/16-18 x 4-1/4" screws (Q) through one crossbar end cap (K) per leg. (See Figure 1)

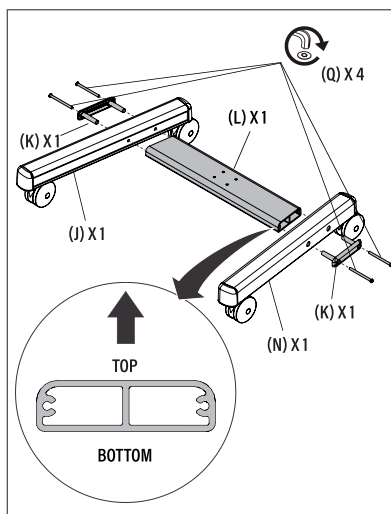

Figure 1

STEP 02

Attach The Lower Column To The Base

Attach the lower column (G) to the crossbar (L) using four 5/16-18 x 2-1/4" screws (R) and 5/16" washers (U). (See Figure 2)

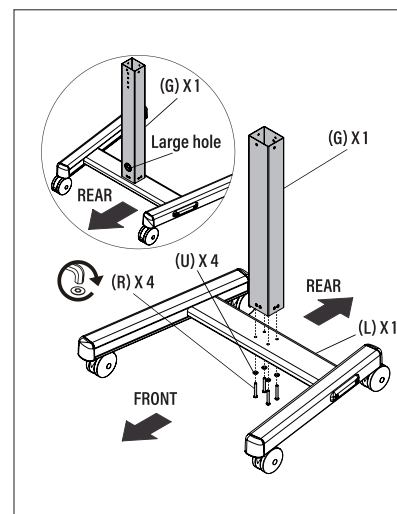

Figure 2

STEP 03

Attach The Face Plate To The Top Column

Install the face plate assembly (A) to the upper column (H) in one of three positions using one connector - stud (E), one connector - no stud (F), and four 5/16-18 flange nuts (W). (See Figure 3)

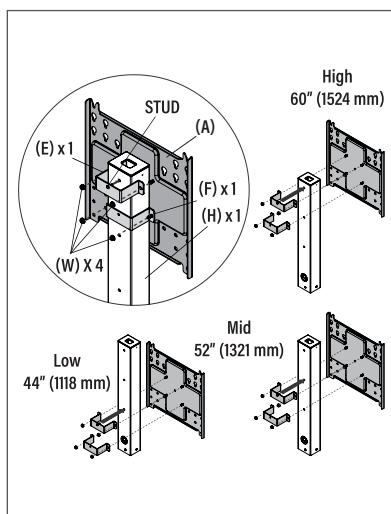

Figure 3

STEP 04

Attach The Upper Column To The Lower Column

Attach the upper column (H) to the lower column (G) using four 10-24 x 1/2" flat head screws (P). (See Figure 4)

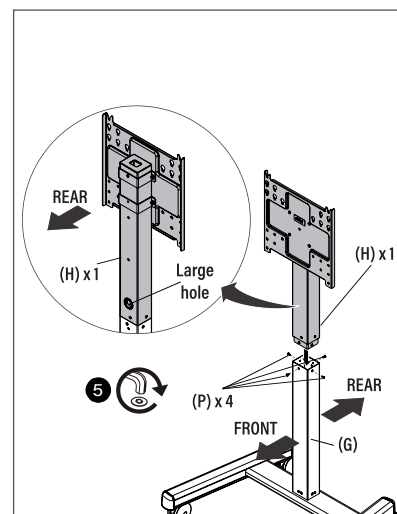
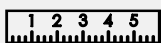

Figure 4

Tools Required for Installation



3/16 x 1" hex bit (included)

#2

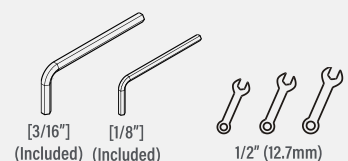

[3/16"] (Included)
[1/8"] (Included)

1/2" (12.7mm)

ATTACHING DISPLAY

▲ WARNING: IMPROPER INSTALLATION (A) CAN LEAD TO MOUNT FALLING OR CAUSING SERIOUS PERSONAL INJURY OR DAMAGE TO EQUIPMENT! DO NOT SUBSTITUTE HARDWARE. ONLY USE HARDWARE PROVIDED OR SPECIFIED BY MANUFACTURER.

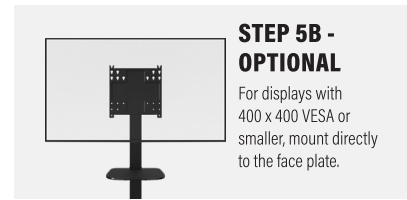
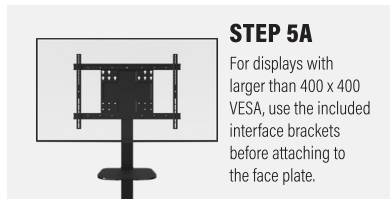

Mount your display with larger than 400 x 400 VESA using the included interface to the face plate

(1) Partially install two 5/16-18 x 5/8" screws (S) into the upper horizontal interface (C). (See Figure 6)

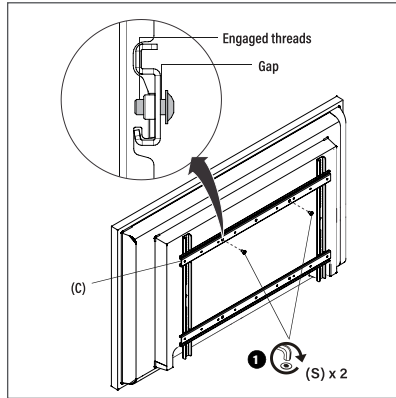

Figure 6

(2) While supporting both sides of display, align two 5/16-18 x 5/8" screws (S) installed in upper horizontal interface (C) with two mounting holes in the face plate assembly (A). (See Figure 7)

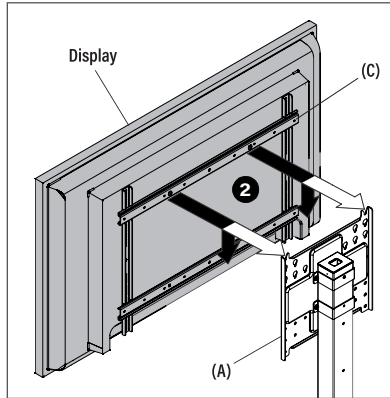

Figure 7

(3) Install two 5/16-18 x 5/8" screws (S) through the face plate assembly (A) into the lower horizontal interface (C). (See Figure 8)

(4) Tighten two 5/16-18 x 5/8" screws (S) in upper horizontal interface. (See Figure 8)

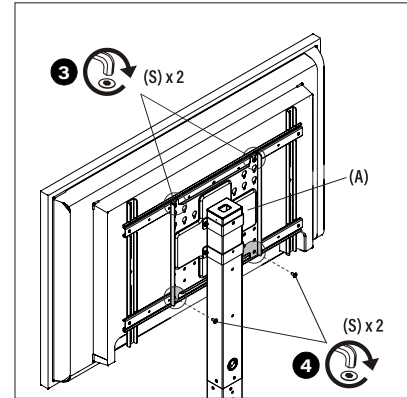

Figure 8

STEP 5B - OPTIONAL

Mount your display with 400 x 400 or smaller VESA pattern directly to the face plate

(1) Select correct screws, nesting spacers (if necessary), and universal washers (if required) from the hardware bag (AA-AH) and attach display to two upper mounting slots in face plate assembly (A). (See Figure 9)

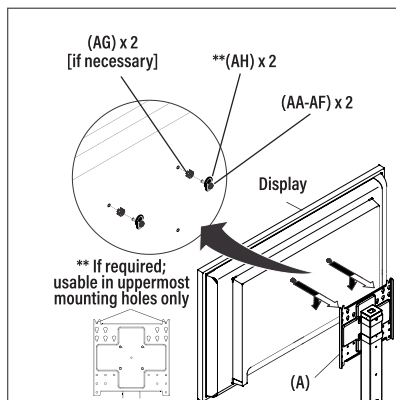

Figure 9

(2) Tighten four screws (AA-AF) in upper and lower mounting slots in face plate assembly (A). (See Figure 10)

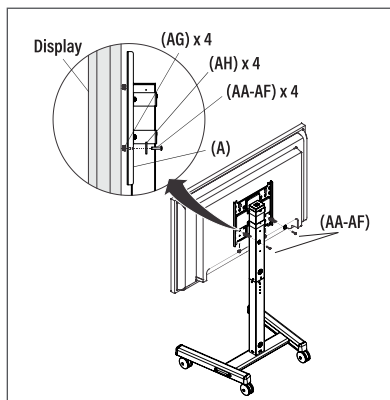

Figure 10

BONUS STEP!

Attach the included shelf to store accessories like keyboards, laptops, and styluses

The shelf assembly (B) can be installed in four different positions to achieve the desired height. (See Figure 11)
To lower column (G) using one connector - stud (E) and two 5/16-18 flange nuts (W).

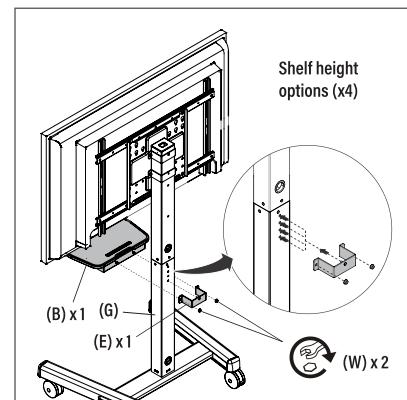

Figure 11

CHIEF[®]
A brand of **legrand**

LEGRAND | AV COMMERCIAL BRANDS
C2G | Chief | Da-Lite | Luxul | Middle Atlantic | Vaddio | Wiremold

INSTALLER INSPIRED | legrandav.com

USA 866.977.3901 av.chief.support@legrand.com CANADA 877.345.4329 av.chief.canada@legrand.com
EMEA +31 495 580 840 av.emea.sales@legrand.com APAC +852 2145 4099 av.asia.sales@legrand.com

©2023 Legrand AV Inc. 230867 Rev A 11/23 Chief is a registered trademark of Legrand AV Inc. All other brand names or marks are used for identification purposes and are trademarks of their respective owners. All patents are protected under existing designations. Other patents pending.

INSTALLATION INSTRUCTIONS

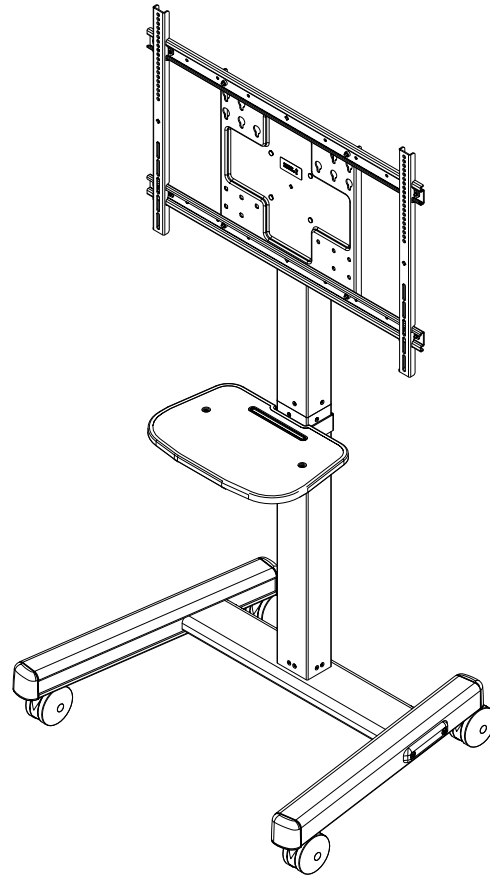

FIT™ Interactive Display Cart

CHIEF®
A brand of **legrand®**

RFCUB

DISCLAIMER

Legrand | AV and its affiliated corporations and subsidiaries (collectively "Legrand | AV"), intend to make this manual accurate and complete. However, Legrand | AV makes no claim that the information contained herein covers all details, conditions or variations, nor does it provide for every possible contingency in connection with the installation or use of this product. The information contained in this document is subject to change without notice or obligation of any kind. Legrand | AV makes no representation of warranty, expressed or implied, regarding the information contained herein. Legrand | AV assumes no responsibility for accuracy, completeness or sufficiency of the information contained in this document.

Chief® is a registered trademark of Legrand AV Inc.

DEFINITIONS

MOUNTING SYSTEM: A MOUNTING SYSTEM is the primary Chief product to which an accessory and/or component is attached.

ACCESSORY: AN ACCESSORY is the secondary Chief product which is attached to a primary Chief product, and may have a component attached or setting on it.

COMPONENT: A COMPONENT is an audiovisual item designed to be attached or resting on an accessory or mounting system such as a video camera, CPU, screen, display, projector, etc.



WARNING: A WARNING alerts you to the possibility of serious injury or death if you do not follow the instructions.



CAUTION: A CAUTION alerts you to the possibility of damage or destruction of equipment if you do not follow the corresponding instructions.



IMPORTANT SAFETY INSTRUCTIONS



WARNING: Failure to read, thoroughly understand, and follow all instructions can result in serious personal injury, damage to equipment, or voiding of factory warranty! It is the installer's responsibility to make sure all mounting systems are properly assembled and installed using the instructions provided.



WARNING: Failure to provide adequate structural strength for this mounting system can result in serious personal injury or damage to equipment! It is the installer's responsibility to make sure the structure to which this mounting system is attached can support five times the combined weight of all equipment. Reinforce the structure as required before installing the component.



WARNING: Use this mounting system only for its intended use as described in these instructions. Do not use attachments not recommended by the manufacturer.



WARNING: Exceeding the weight capacity can result in serious personal injury or damage to equipment! It is the installer's responsibility to make sure the combined weight of all components attached to the head assembly does not exceed 175 lbs (79.38 kg). Use with heavier televisions may result in instability causing tip over resulting in death or serious injury. See Figure below for reference.



WARNING: Exceeding the weight capacity can result in serious personal injury or damage to equipment! It is the installer's responsibility to make sure the combined weight of all components placed on the shelf does not exceed 10 lbs (4.5 kg). Use with heavier components may result in instability causing tip over resulting in death or serious injury. See Figure below for reference.

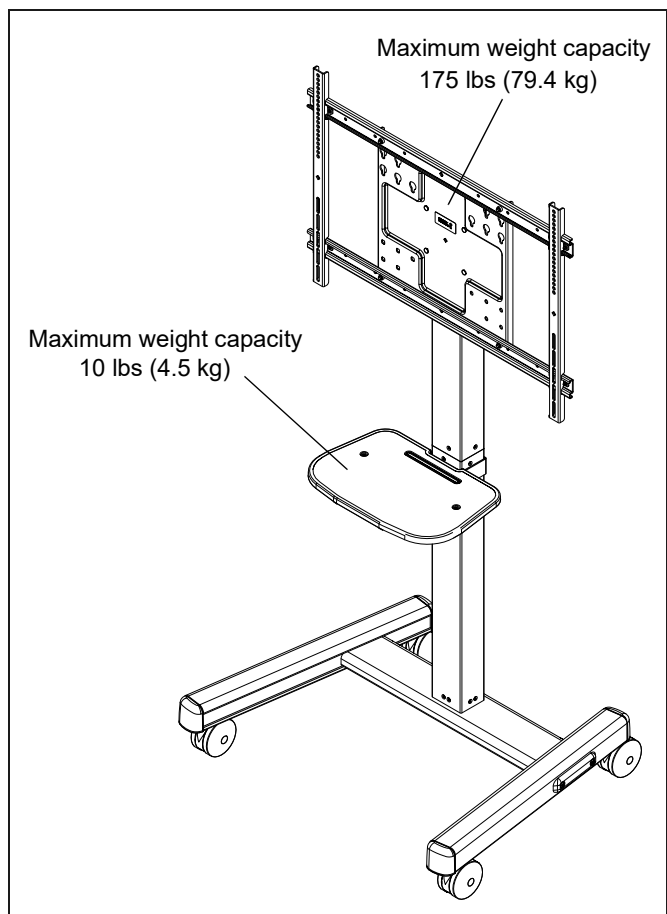

WARNING: This mounting system is designed to be used with displays between 55" and 86" with a maximum VESA pattern of 800x600.



WARNING: Never operate this mounting system if it is damaged. Return the mounting system to a service center for examination and repair.

⚠ WARNING: Do not use this product outdoors.

⚠ WARNING: RISK OF INJURY TO PERSONS! Do not place video equipment such as televisions or computer monitors on cart legs.

⚠ WARNING: RISK OF INJURY OR DEATH! Placing a remote control or toy on the cart may encourage a child to climb onto the cart causing the cart to tip over onto the child. DO NOT place remote controls or toys on the cart!

⚠ WARNING: RISK OF SERIOUS INJURY OR DEATH! Relocating audio and/or video equipment to the cart may result in the cart collapsing or overturning onto a child. DO NOT relocate audio and/or video equipment to the cart!







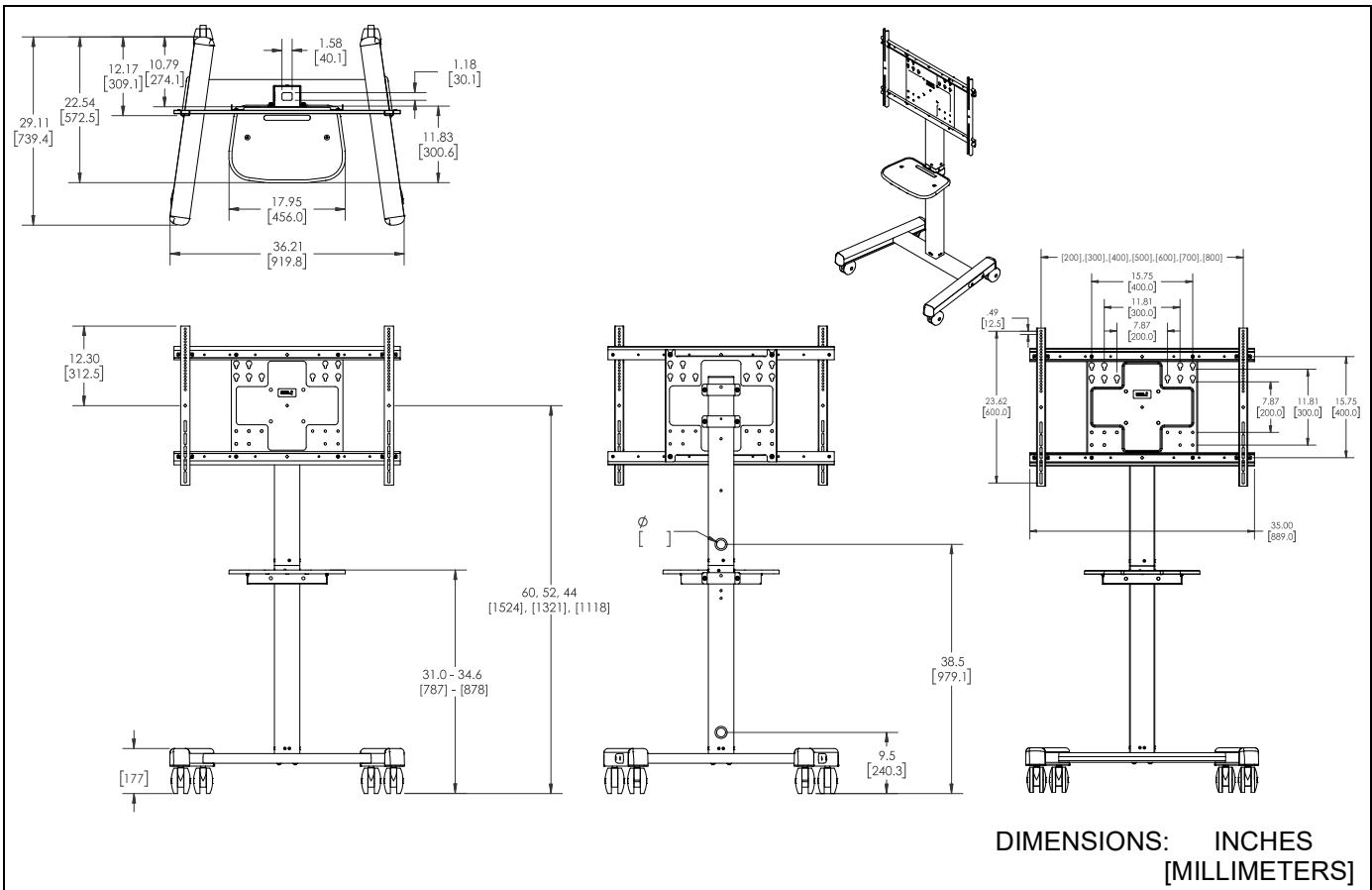

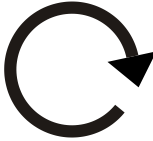

NOTE: This mounting system has no user-serviceable parts.

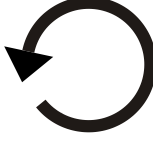
--SAVE THESE INSTRUCTIONS--

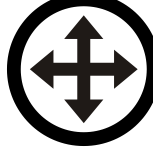
DIMENSIONS



LEGEND

	Tighten Fastener Apretar elemento de fijación Befestigungsteil festziehen Apertar fixador Serrare il fissaggio Bevestiging vastdraaien Serrez les fixations		Pencil Mark Marcar con lápiz Stiftmarkierung Marcar com lápis Segno a matita Potloodmerkteken Marquage au crayon
	Loosen Fastener Aflojar elemento de fijación Befestigungsteil lösen Desapertar fixador Allentare il fissaggio Bevestiging losdraaien Desserrez les fixations		Drill Hole Perforar Bohrloch Fazer furo Praticare un foro Gat boren Percez un trou
	Phillips Screwdriver Destornillador Phillips Kreuzschlitzschraubendreher Chave de fendas Phillips Cacciavite a stella Kruiskopschroevendraaier Tournevis à pointe cruciforme		Adjust Ajustar Einstellen Ajustar Regolare Afstellen Ajuster
	Open Ended Wrench Llave de boca Gabelschlüssel Chave de bocas Chiave a punte aperte Steeksleutel Clé à fourche		Remove Quitar Entfernen Remover Rimuovere Verwijderen Retirez
	By Hand A mano Von Hand Com a mão A mano Met de hand À la main		Optional Opcional Optional Opcional Opzionale Optie En option
	Hex Head Wrench Llave de cabeza hexagonal Sechskantschlüssel Chave de cabeça sextavada Chiave esagonale Zeskantsleutel Clé à tête hexagonale		Security Wrench Llave de seguridad Sicherheitsschlüssel Chave de segurança Chiave di sicurezza Veiligheidssleutel Clé de sécurité

TOOLS REQUIRED FOR INSTALLATION

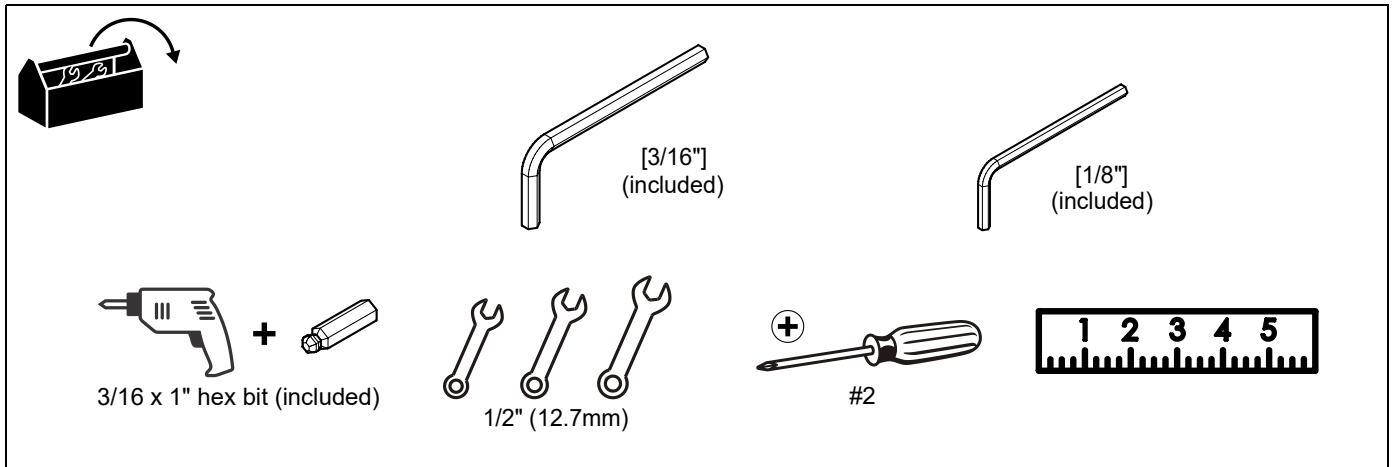

PARTS

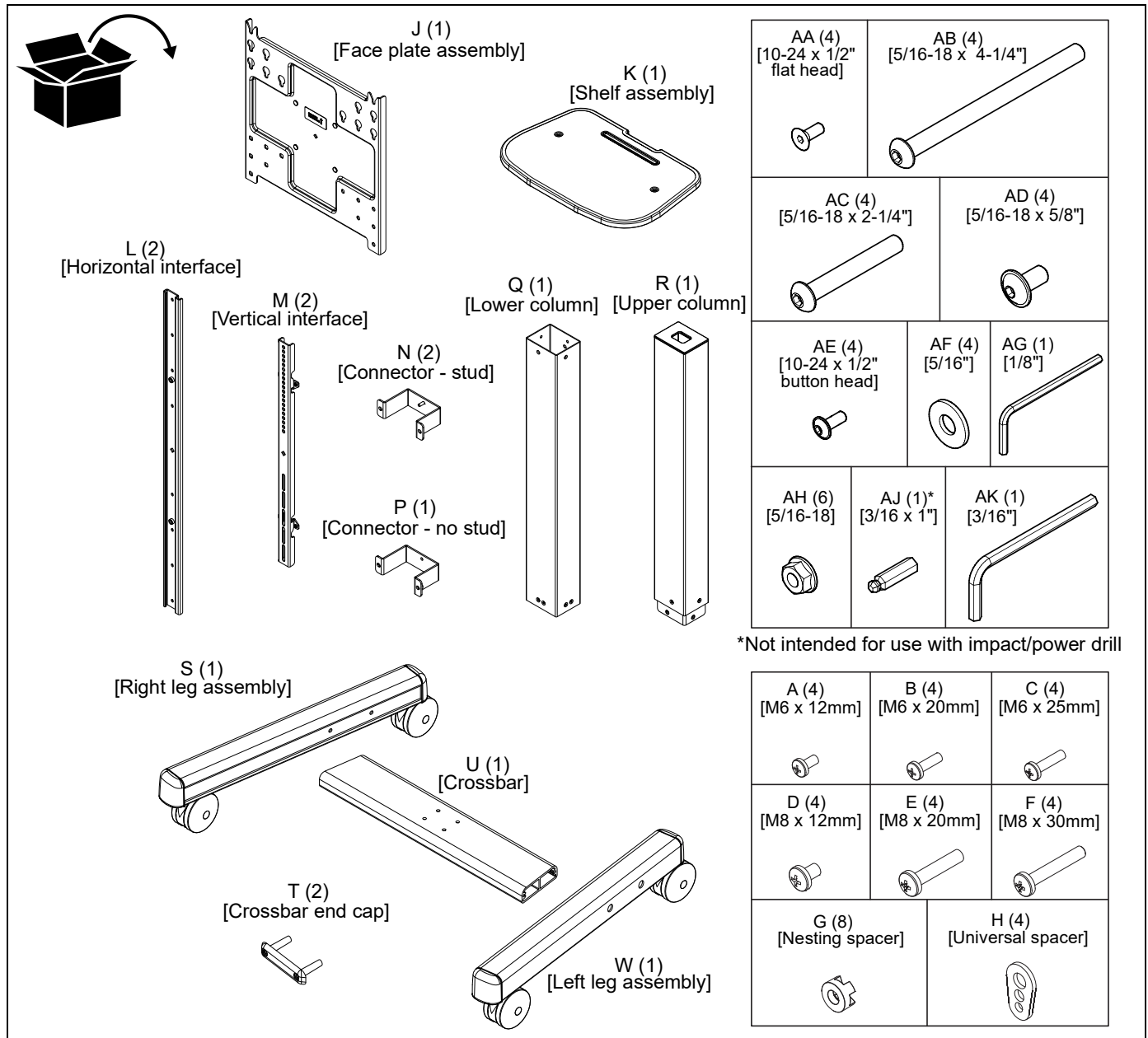

Assembly



CAUTION: Attachment holes may be damaged if a power drill is used to insert button head cap screws. Screws should first be inserted and turned **BY HAND** with the hex key or with a handheld screwdriver **BEFORE** using the 3/16 x 1" hex head bit (AJ) to complete the attachment.



CAUTION: Hex head bit (AJ) is not intended for use with a power drill. Bit failure may occur if used in this manner.

Assembling Cart

1. Assemble the right leg assembly (S) and left leg assembly (W) to the crossbar (U) using two 5/16-18 x 4-1/4" screws (AB) through one crossbar end cap (T) per leg. (See Figure 1)

IMPORTANT ! : Orient the crossbar (U) so that the top side (rounded edges) is facing up. (See Figure 1)

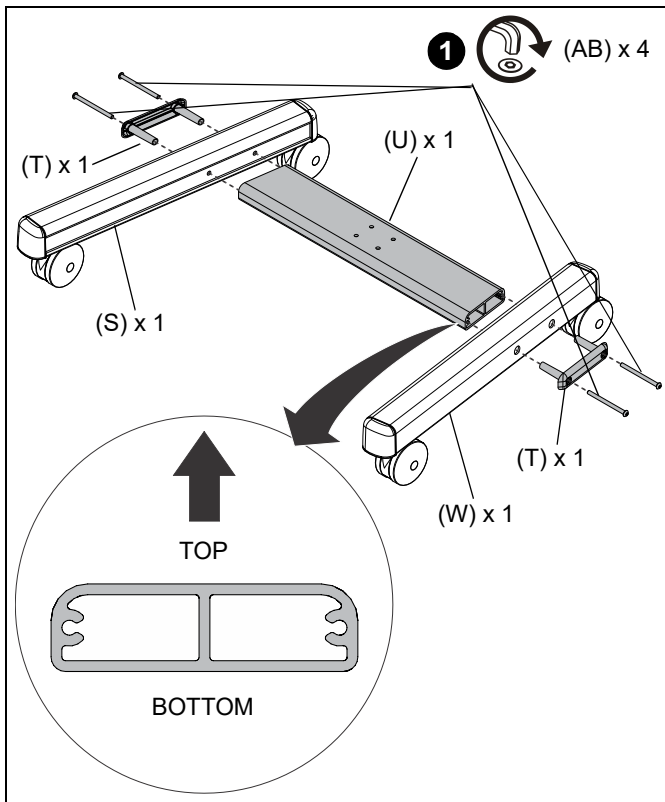

Figure 1

2. Attach the lower column (Q) to the crossbar (U) using four 5/16-18 x 2-1/4" screws (AC) and 5/16" washers (AF). (See Figure 2)

NOTE: Make sure the large hole in the lower column (Q) is oriented towards the back side of the cart.

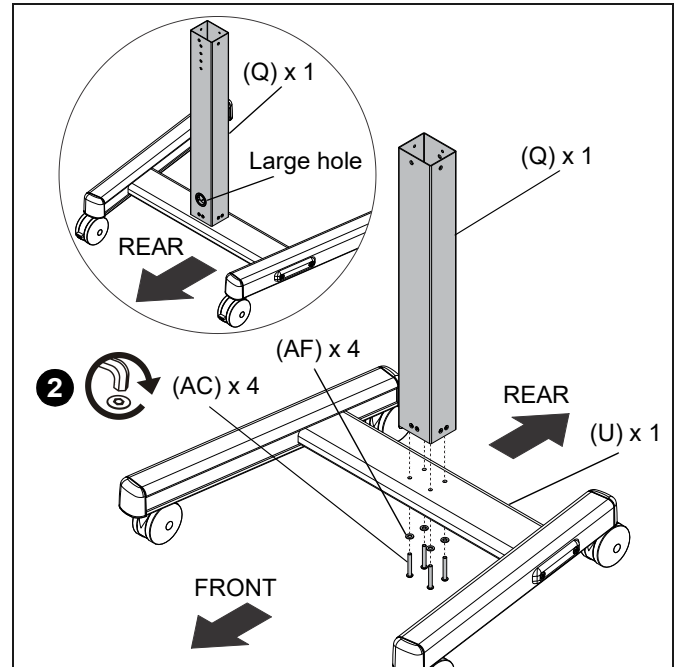

Figure 2

3. Install the face plate assembly (J) to the upper column (R) in one of three positions using one connector - stud (N), one connector - no stud (P), and four 5/16-18 flange nuts (AH). (See Figure 3)

NOTE: Position the stud in the upper connector (N) into one of three holes depending on desired position.

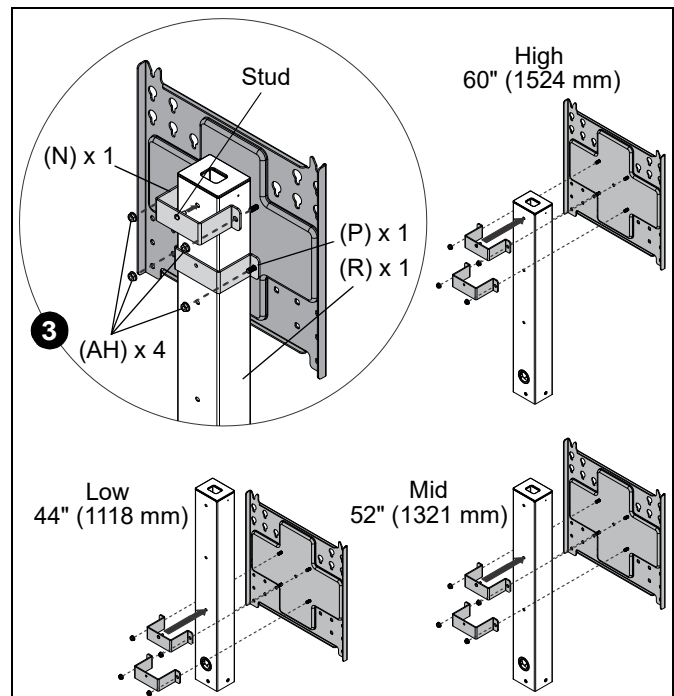

Figure 3

4. Attach the upper column (R) to the lower column (Q) using four 10-24 x 1/2" flat head screws (AA). (See Figure 4)

NOTE: Make sure the large hole in the upper column (R) is oriented towards the back side of the cart.

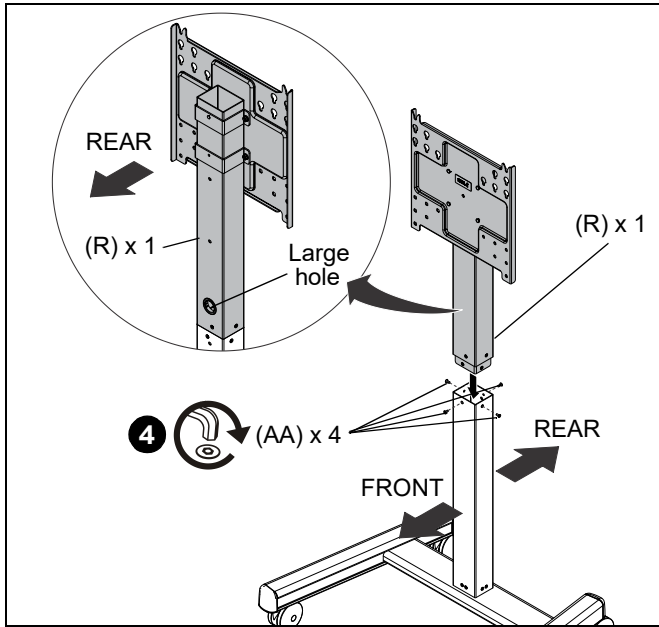

Figure 4

Attaching Display



WARNING: IMPROPER INSTLLATION CAN LEAD TO MOUNT FALLING OR CAUSING SERIOUS PERSONAL INJURY OR DAMAGE TO EQUIPMENT! DO NOT substitute hardware. Only use hardware provided or specified by manufacturer.

NOTE: For VESA patterns 400x400 or smaller, the display can be installed directly to the face plate assembly (J). Skip ahead to the **Attaching Display to Cart** section if this option is desired.

Small and Large VESA Patterns

1. Determine and mark the vertical center position between the left-side upper and lower mounting holes in display. (See Figure 5)
2. Determine and mark the vertical center position between the right-side upper and lower mounting holes in display. (See Figure 5)
3. Orient vertical mounting bracket (M) so that mounting slots are on bottom and mounting holes are on top. (See Figure 5)
4. Align mounting holes in vertical mounting bracket (M) with upper and lower mounting holes in display.
5. Adjust vertical mounting bracket (M) position until mark made in Step 1 aligns with center mark in vertical mounting bracket (M).
6. Select correct screws, nesting spacers (if necessary), and universal washers (if required) from the hardware bag (A-H) and attach brackets to back of screen.

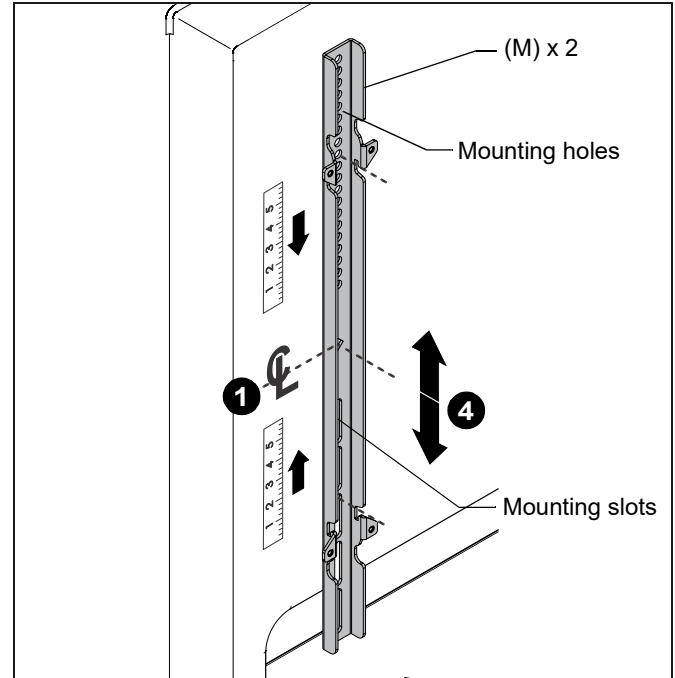

Figure 5

IMPORTANT ! : The M8 screws do NOT require a washer. Use the universal washer (H) only with M6 screws (A, B, or C).

NOTE: The nesting spacers (G) may be used separately, or put two together in different configurations to create different size spacers. (See Figure 6)

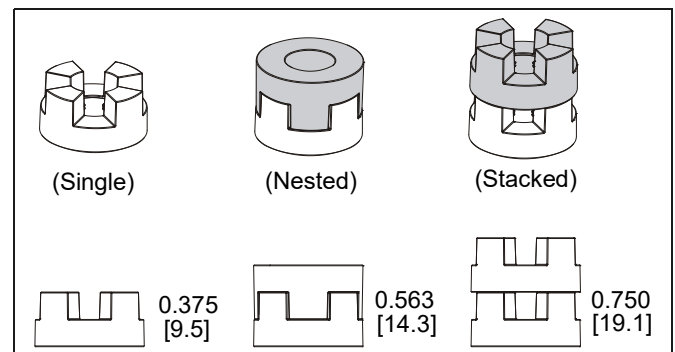

Figure 6

7. If the display has a recessed mounting surface, protrusions, or a power box, a spacer and longer mounting hardware must be placed between display and vertical interface (M).
8. Repeat Steps 3-6 for right-side vertical mounting bracket using the same hole locations to align brackets horizontally.

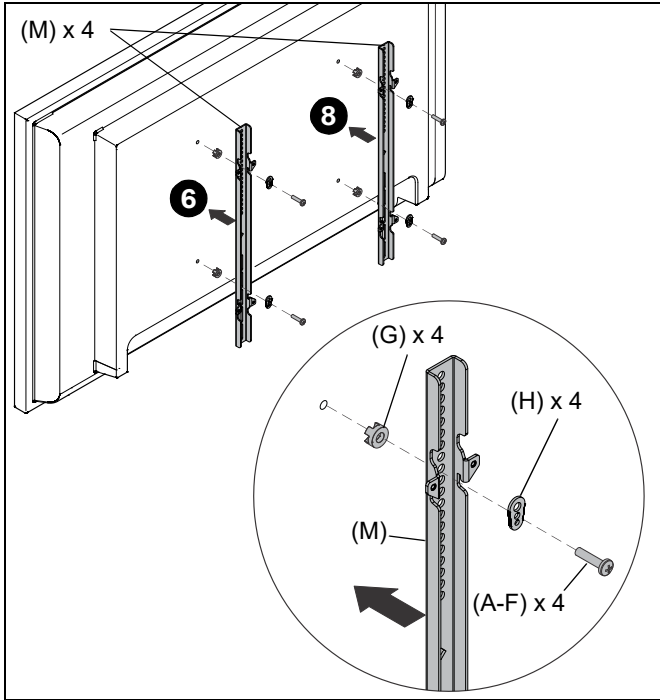

Figure 7

9. Determine and mark the horizontal center position between the left and right TOP mounting holes in display. (See Figure 8)
10. Determine and mark the horizontal center position between the left and right BOTTOM mounting holes in display. (See Figure 8)
11. Orient upper horizontal interface (L) so that flanges are facing towards display and resting in recessed area of left and right vertical interfaces (M). (See Figure 8)
12. Adjust upper horizontal interface (L) position until center diamond in horizontal interface (L) aligns with mark made in Step 9, and mounting holes and slots in horizontal interface (L) are aligned with threaded holes in mounting tabs of left and right vertical interfaces (M). (See Figure 8)

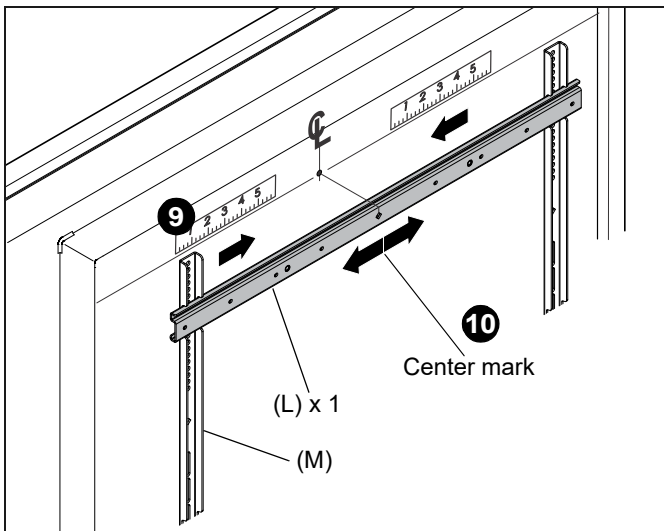

Figure 8

13. Use 1/8" hex key (AG) to secure upper horizontal interface (L) to left and right vertical interfaces (M) using four 10-24 x 1/2" button head screws (AE). (See Figure 9)

14. Repeat steps 10-13 to install lower horizontal interface (L).

IMPORTANT ! : The orientation of, and mounting holes used, when installing the lower horizontal interface must be the same as the upper horizontal interface (L). Vertically align upper and lower interfaces by aligning holes or end of slots. (See Figure 9)

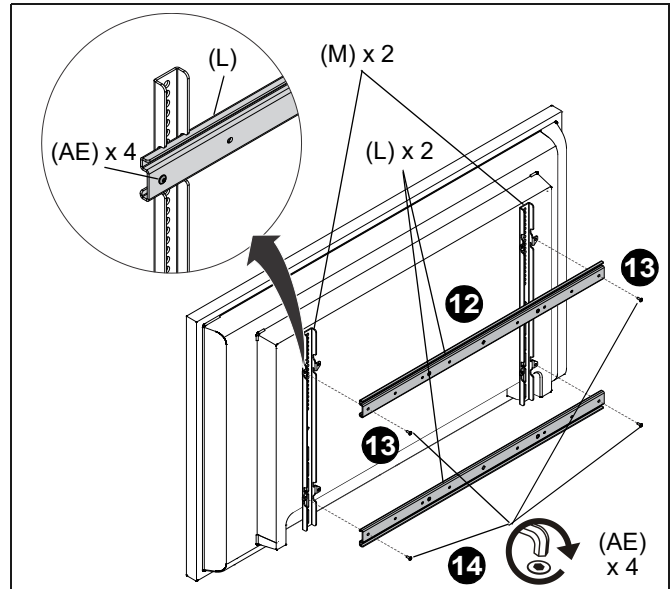

Figure 9

Attaching Display to Cart



WARNING: EXCEEDING MAXIMUM WEIGHT CAPACITY MAY LEAD TO SERIOUS PERSONAL INJURY OR DAMAGE TO EQUIPMENT! It is the installer's responsibility to ensure the total amount of weight placed on the cart does not exceed 175 lbs (79.38 kg).



CAUTION: Before attaching display to cart, set the brakes on the back wheels by pressing down on the tab. (See Figure 10)

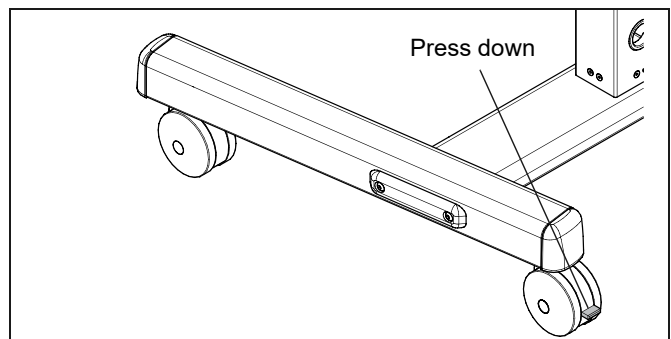

Figure 10

Interface Brackets to Face Plate Assembly

1. Partially install two 5/16-18 x 5/8" screws (AD) into the upper horizontal interface (L). (See Figure 11)

NOTE: Make sure enough threads are engaged to secure the screws into the horizontal interface (L).

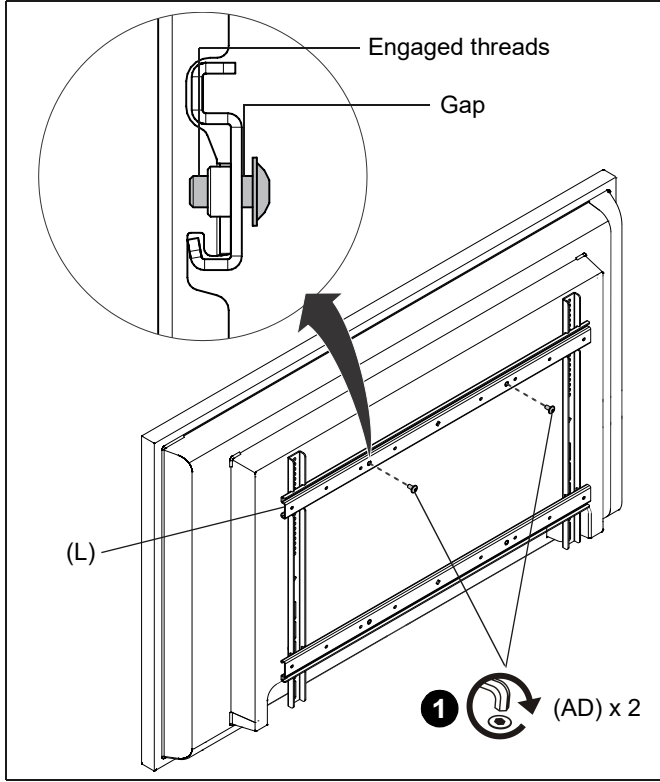

Figure 11

2. While supporting both sides of display, align two 5/16-18 x 5/8" screws (AD) installed in upper horizontal interface (L) with two mounting holes in the face plate assembly (J). (See Figure 12)

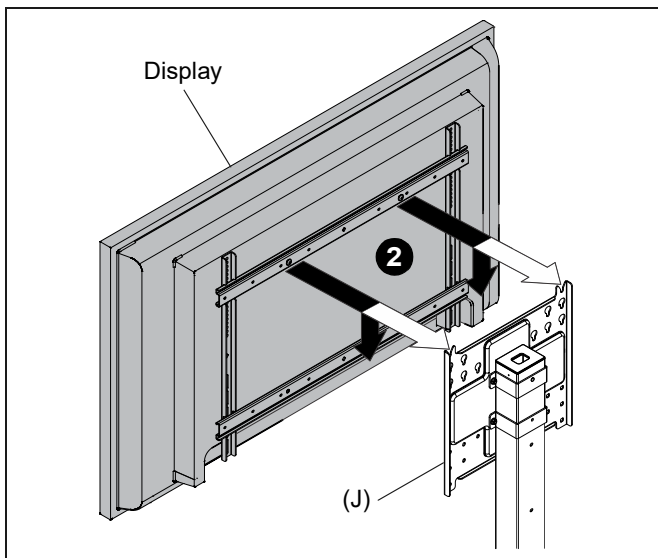

Figure 12

3. Lower display into place, making sure the screws are properly seated in lower areas of mounting holes. (See Figure 13)

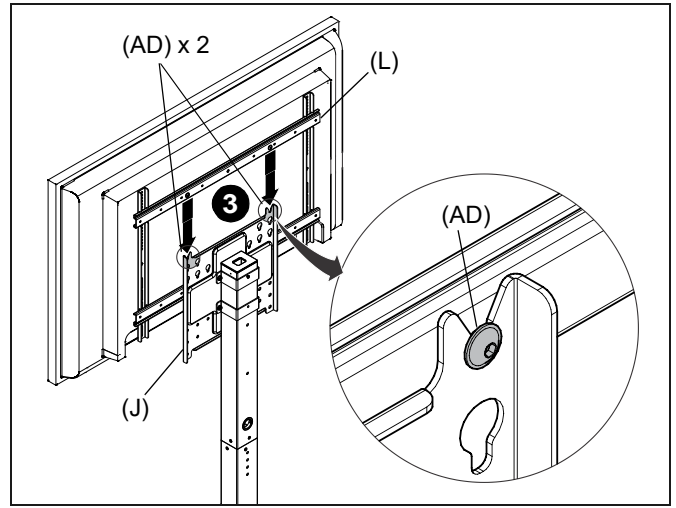

Figure 13



WARNING: DISPLAY MAY WEIGH IN EXCESS OF 40 LBS! Always use two people and proper lifting techniques when installing or positioning display on cart.

4. Install two 5/16-18 x 5/8" screws (AD) through the face plate assembly (A) into the lower horizontal interface (L). (See Figure 14)
5. Tighten two 5/16-18 x 5/8" screws (AD) in upper horizontal interface. (See Figure 14)

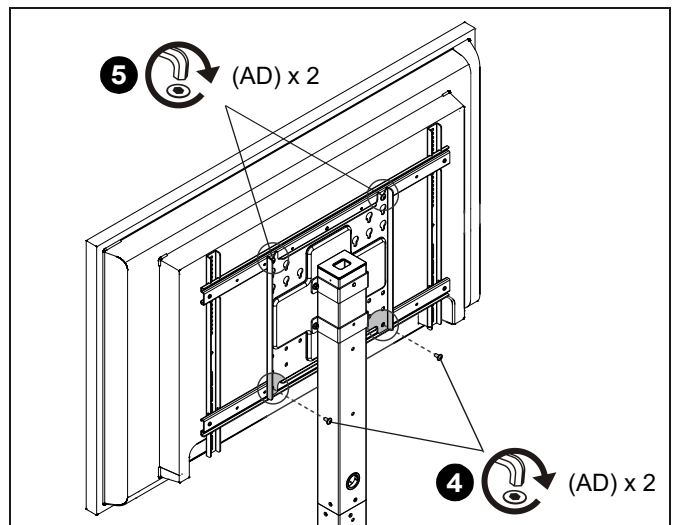

Figure 14



WARNING: IMPROPER INSTALLATION CAN LEAD TO CART OR DISPLAY FALLING CAUSING SERIOUS PERSONAL INJURY OR DAMAGE TO EQUIPMENT! Ensure mounting screws are completely engaged in mounting holes.

Display to Face Place Assembly

NOTE: The display can only be installed directly to the face plate assembly (J) when the VESA pattern is 400x400 or smaller.

1. Select correct screws, nesting spacers (if necessary), and universal washers (if required) from the hardware bag (A-H) and partially install into two upper mounting holes in display. (See Figure 15)

NOTE: The nesting spacers (G) may be used separately, or put two together in different configurations to create different size spacers. (See Figure 6)

2. If the display has a recessed mounting surface, protrusions, or a power box, a spacer and longer mounting hardware must be placed between display and face plate assembly.
3. While supporting both sides of display, align two screws (A-F) installed in display with two mounting holes in the face plate assembly (J). (See Figure 15)
4. Lower display into place, making sure the screws are properly seated in lower areas of mounting holes.

NOTE: Universal spacers (H) can only be used when installing into the two uppermost mounting holes in the face plate assembly (J).

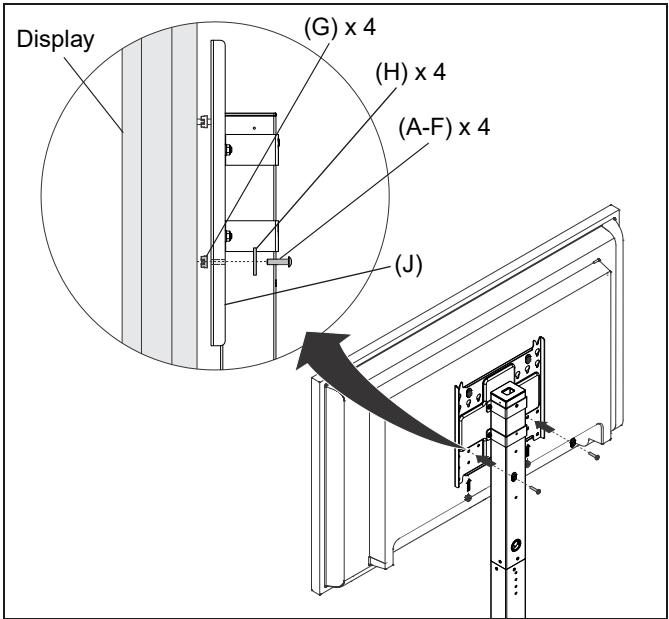

Figure 16

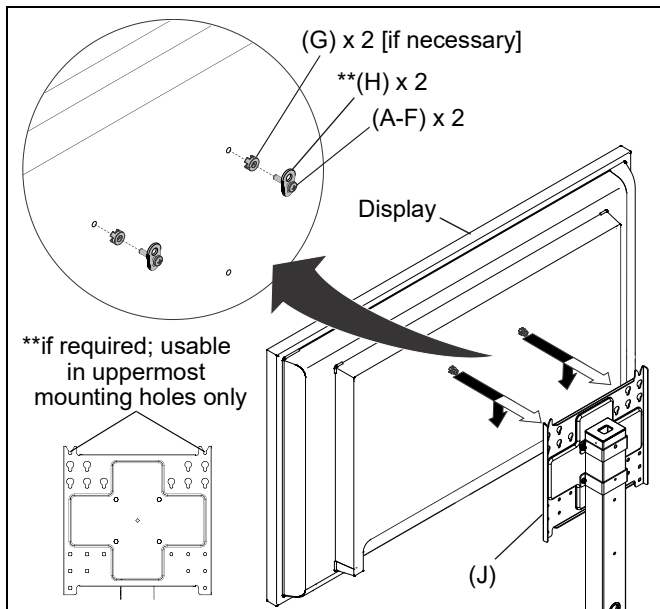

Figure 15

5. Select correct screws, nesting spacers (if necessary), and universal washers (if required) from the hardware bag (A-H) and attach display to two lower mounting holes in face plate assembly (J). (See Figure 16)

NOTE: Use the same hardware in both the upper mounting slots and lower mounting holes.

Attaching Shelf to Cart

1. Install the shelf assembly (K) to the front of the lower column (Q) using one stud connector (N) and two 5/16-18" hex nuts (AH). (See Figure 17)

NOTE: The shelf assembly (K) can be installed in four different positions to achieve the desired height. (See Figure 17)

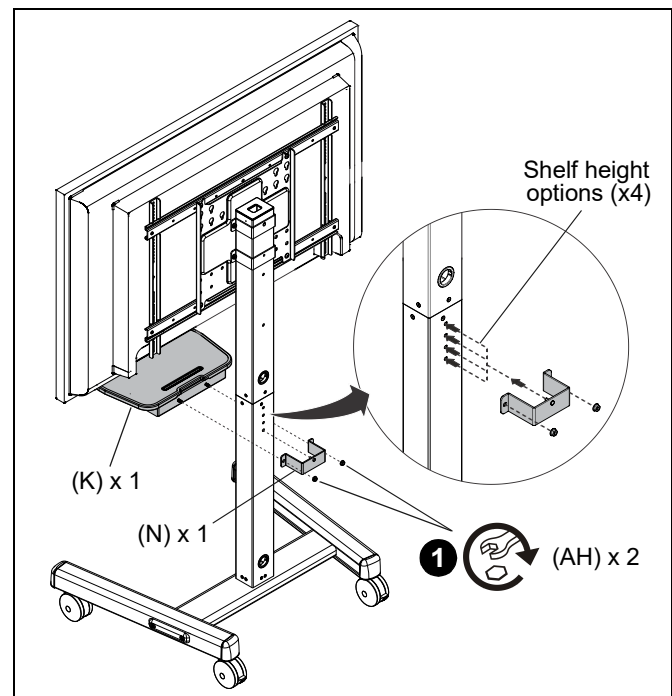

Figure 17

Cable Management

1. The display power cord, as well as any signal cables or accessory power cords, can be run through the top and down through the post to exit out the back. (See Figure 18)

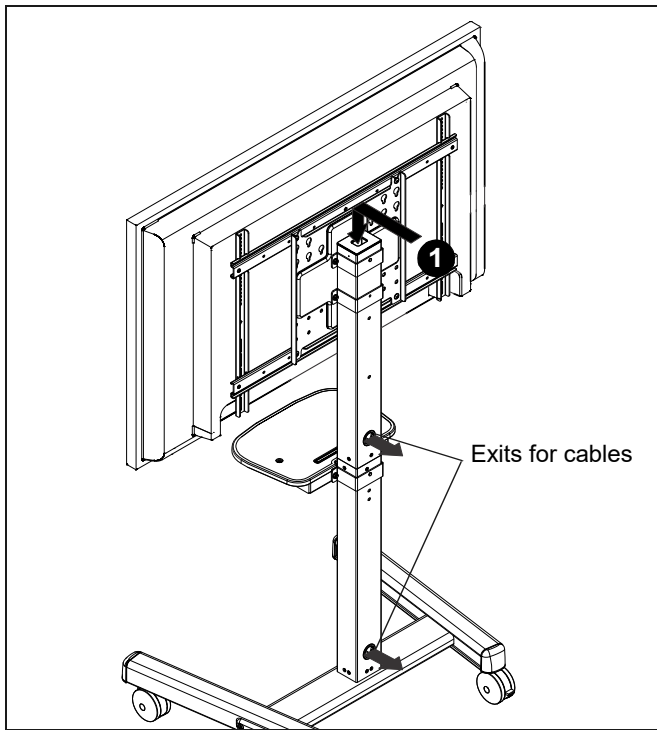

Figure 18

NOTE: The cart can support screen sizes up to a maximum of 86" wide.

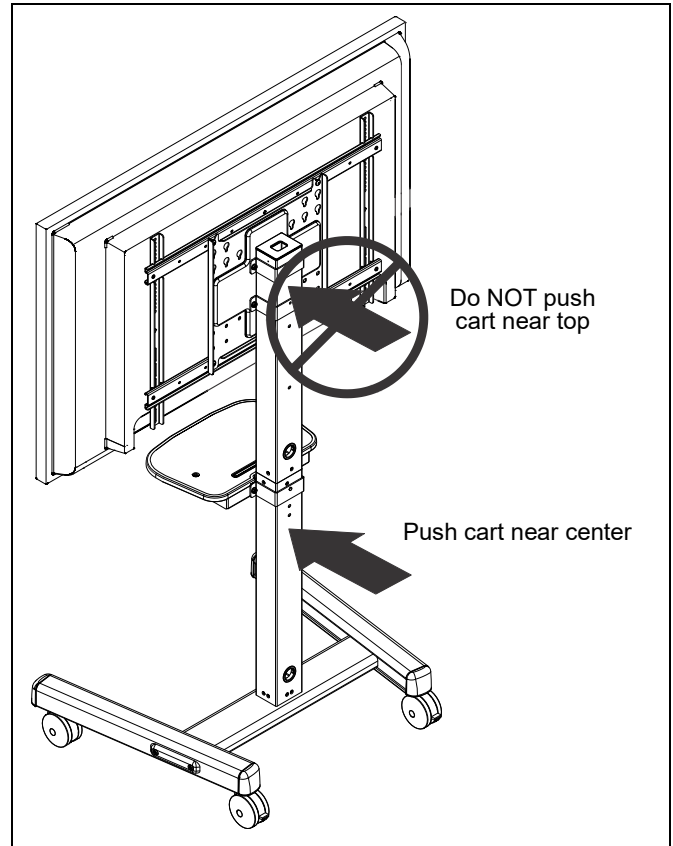

Figure 19

Cart Use and Maintenance



WARNING: Exceeding the weight capacity can result in serious personal injury or damage to equipment! It is the installer's responsibility to make sure the combined weight of all accessories and components located between the RFCUB up to (and including) the display does not exceed 175 lbs (79.38 kg).



WARNING: RISK OF SERIOUS INJURY OR DEATH! Placing a remote control or toy on the cart may encourage a child to climb onto the cart causing the cart to tip over onto the child. DO NOT place remote controls or toys on the cart!



WARNING: RISK OF SERIOUS INJURY OR DEATH! Relocating audio and/or video equipment to the cart may result in the cart collapsing or overturning onto a child. DO NOT relocate audio and/or video equipment to the cart



WARNING: CART CAN TIP OVER RESULTING IN RISK OF INJURY. Do not allow children under 16 to move cart. Only adults should move this cart. Move cart slowly. Apply moving force on narrow dimension. Never apply force at top - always push near middle. Push, don't pull.

NOTE: The cart has no user serviceable parts.

1. Always place cart on level surface.
2. Always lock the wheels when the cart is not moving.
3. Check and tighten the hex nuts on the casters occasionally (See Figure 20). These should be checked especially after use on uneven ground.

NOTE: The casters do not require additional lubrication.

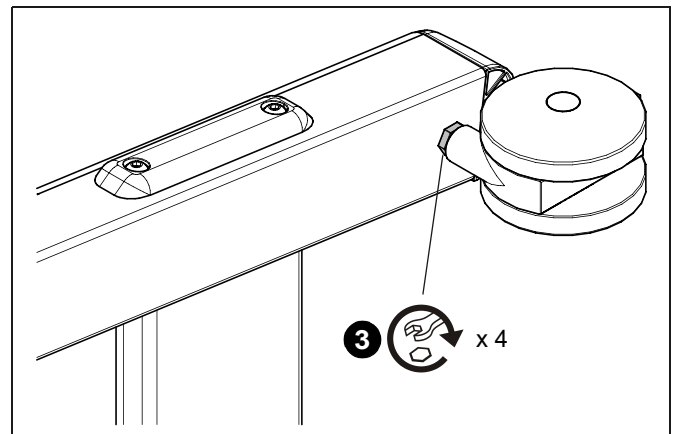

Figure 20

CHIEF®

A brand of  **legrand®**

8800-003391 Rev02
©2024 Legrand | AV
www.legrandav.com
01/2024

USA/International	A 6436 City West Parkway, Eden Prairie, MN 55344 P 800.582.6480 / 952.225.6000 F 877.894.6918 / 952.894.6918
Europe	A Franklinstraat 14, 6003 DK Weert, Netherlands P +31 (0) 495 580 852 F +31 (0) 495 580 845
Asia Pacific	A Office No. 918 on 9/F, Shatin Galleria 18-24 Shan Mei Street Fotan, Shatin, Hong Kong P 852 2145 4099 F 852 2145 4477

