

Clarke®

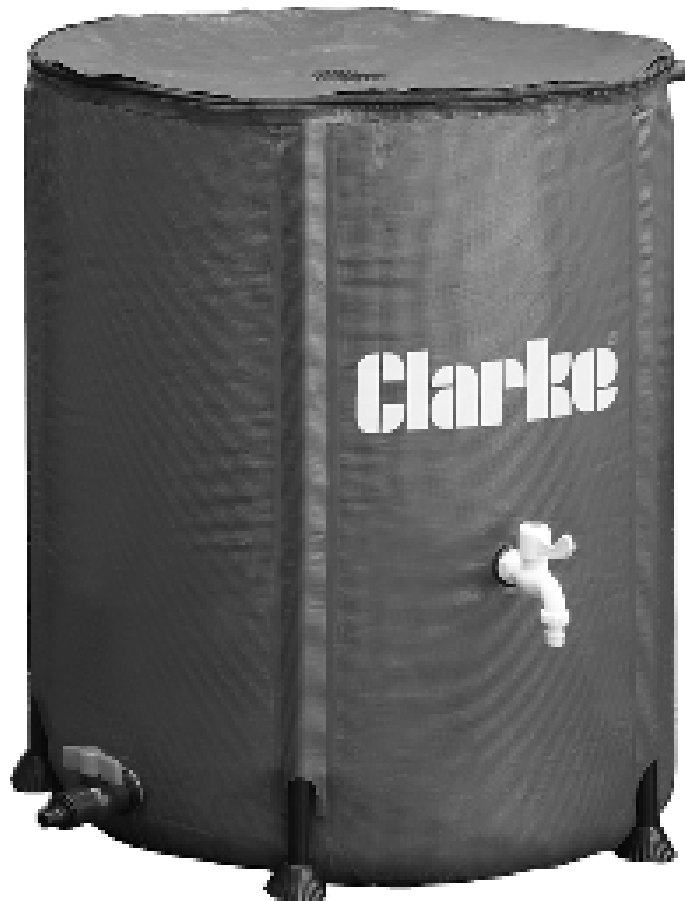

200L COLLAPSIBLE WATER BUTT MODEL NO: WB200

PART NO: 3402238

ASSEMBLY & USER INSTRUCTIONS

D1021

GUARANTEE

This product is guaranteed against faulty manufacture for a period of 12 months from the date of purchase. Please keep your receipt which will be required as proof of purchase.

This guarantee is invalid if the product is found to have been abused or tampered with in any way, or not used for the purpose for which it was intended.

Faulty goods should be returned to their place of purchase, no product can be returned to us without prior permission.

This guarantee does not effect your statutory rights.

SPECIFICATIONS

Product Part No.	WB200
Volume	200 Litres
Dimensions (L x W x H)	590mm x 590mm x 710mm
Weight (Empty)	2.05kg
Weight (Full)	202.05kg
Material	Ripstop PVC
Temperature Range	-35°C to 80°C

OVERVIEW



1	200Lt Ripstop PVC Water Tank	5	32mm x 1.2m Hose
2	Support Poles (x5)	6	High Outlet Tap
3	Feet (x5)	7	Low Drain Tap
4	Ripstop PVC Repair Patch	8	Overflow Pipe

ASSEMBLY

NOTE: Steps 1 & 2 only shows the lower drain tap as an example, but also applies to the high outlet tap.

1. Take the outlet/drain taps and unscrew the filter caps and O ring washers.

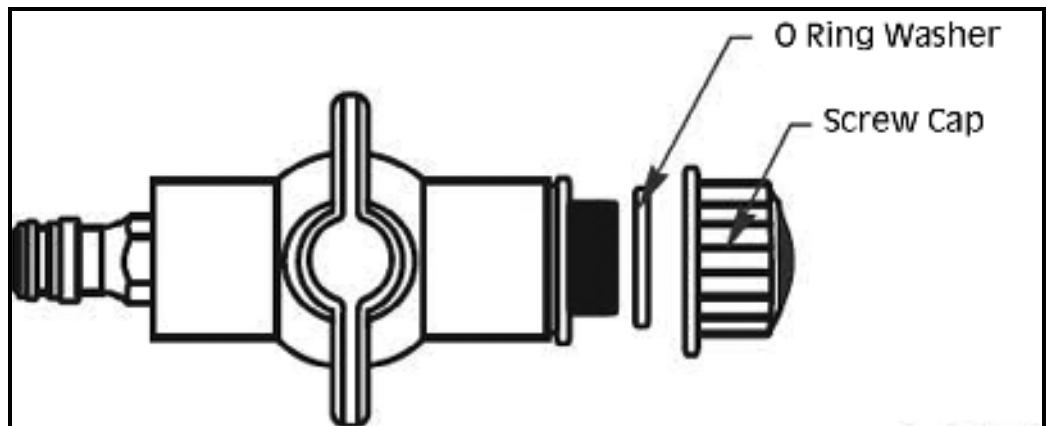

2. Place the main body of the outlet/drain tap through the outlet holes in the tank exterior and replace the O ring and filter screw cap on the inside of the water tank, as shown.

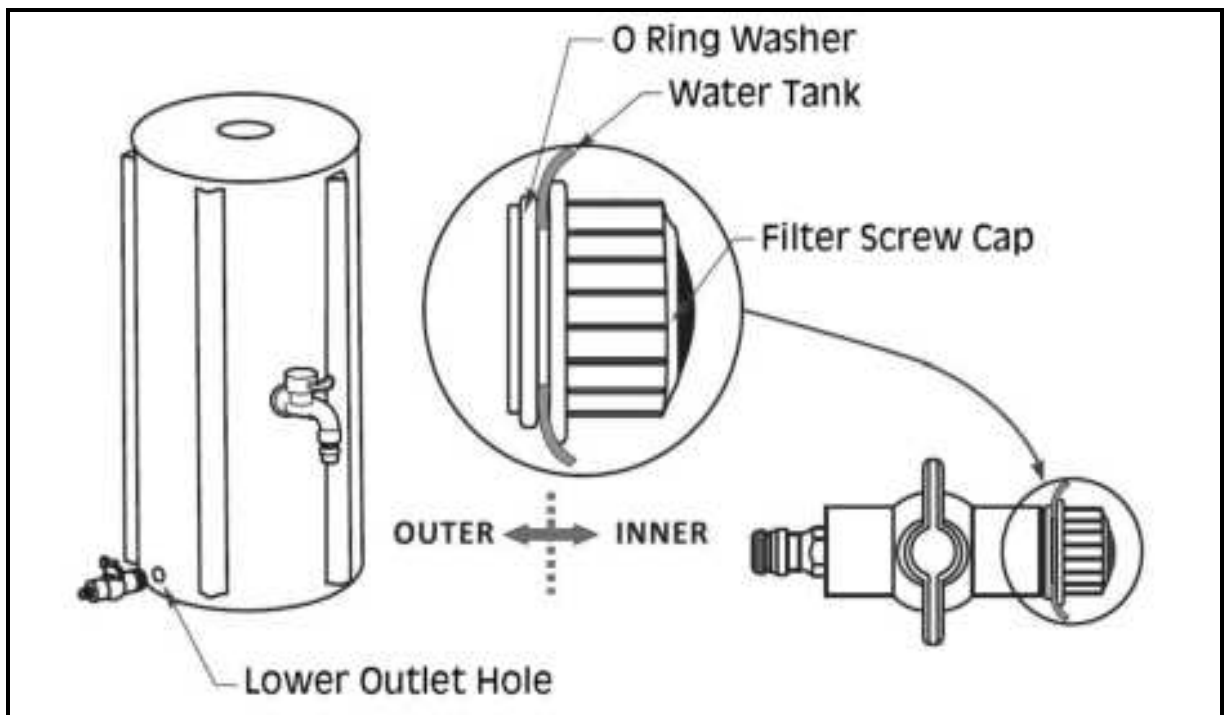

3. Take the overflow pipe and unscrew the filter screw cap.

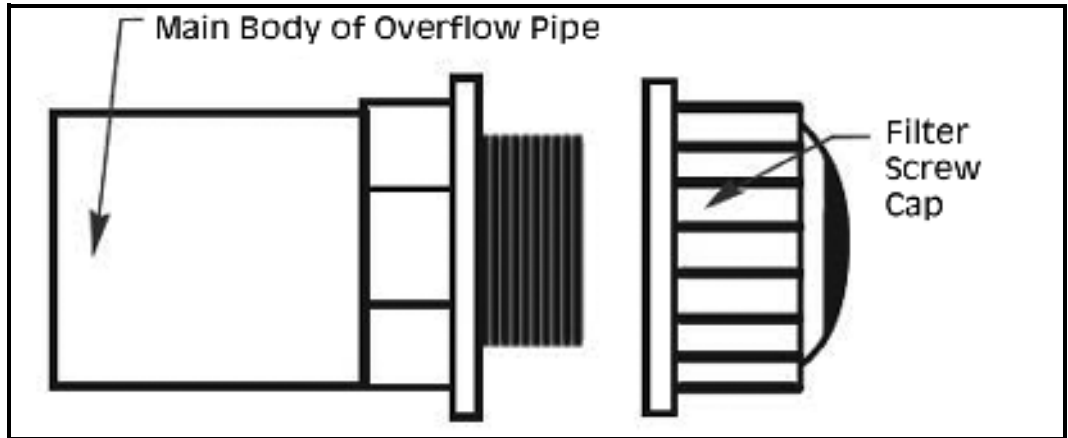

4. Place the main body of the overflow pipe through the outlet hole in the tank exterior and replace the filter screw cap on the inside of the water tank, as shown.

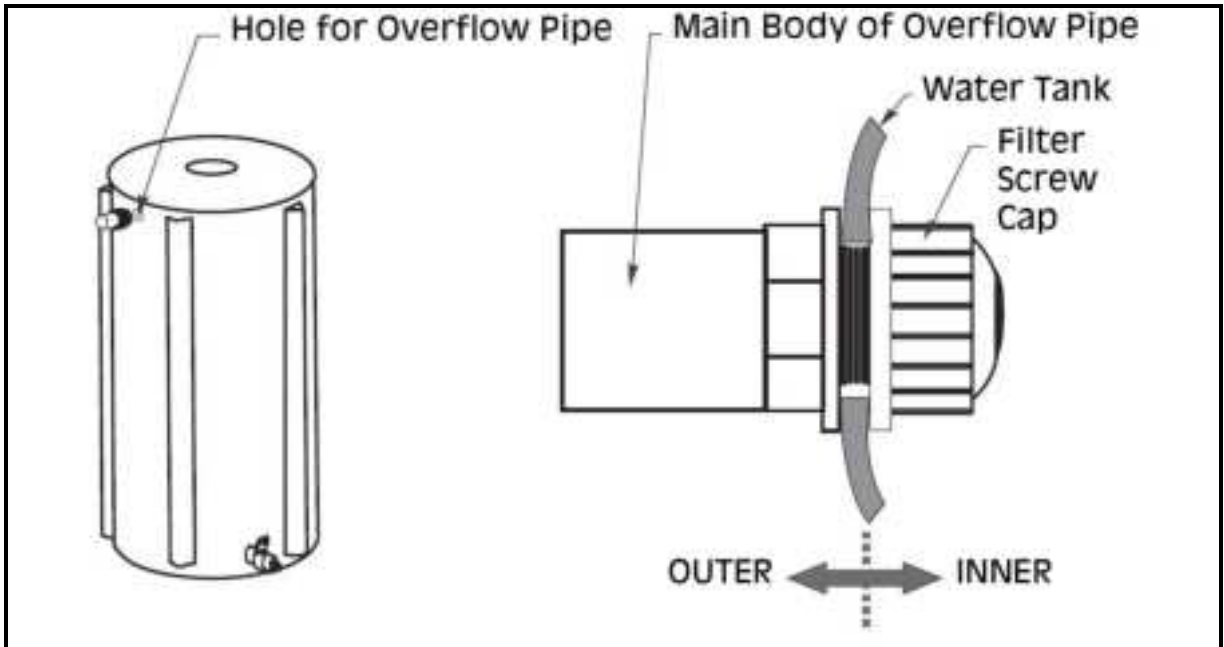

5. Place the feet on the support poles and slide the poles into the loops on the outside of the water tank.

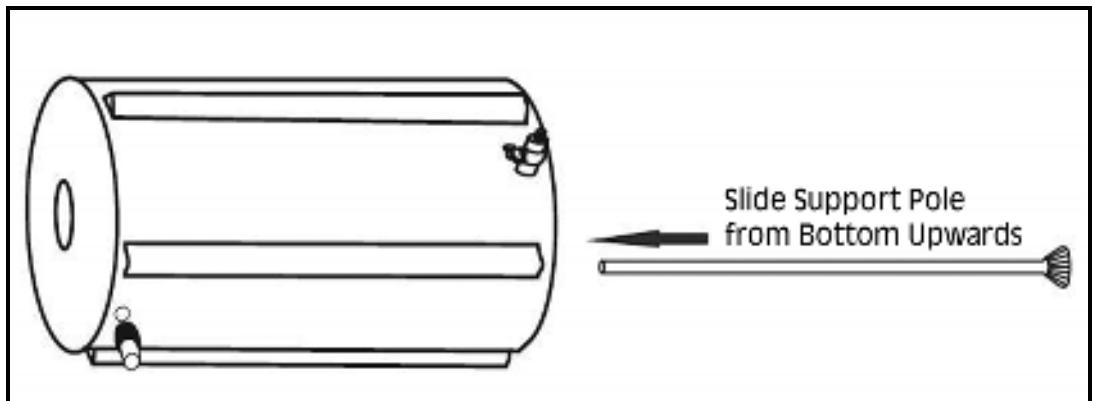

OPERATION & MAINTENANCE INSTRUCTIONS

OPERATION

1. The lid of the water tank has a dual zip for easy access to the water.

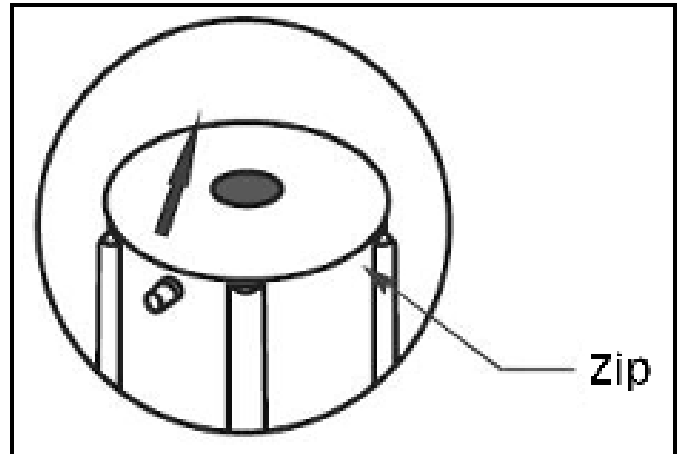

2. The lid has a polyester/PVC mesh filter in the centre to stop large impurities such as leaves entering the tank.

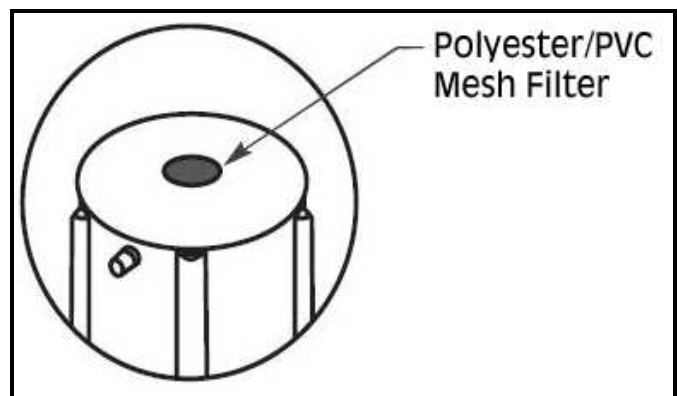

3. If required, the 1.2m hose can be attached to the overflow pipe to direct any overflow away from the water tank and surrounding area.
4. Once assembled, place the water tank on level and solid ground to ensure it is well balanced and unlikely to topple over.
5. Once in place, pour a small quantity of water into the tank in order to stabilise it.
6. The lower tap is designed to attach to a standard hosepipe female connector (not supplied). This will allow the tank to be connected to a variety of garden/maintenance tools such as pressure washers.

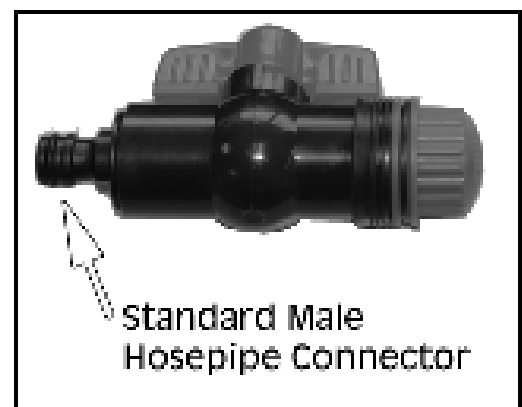

MAINTENANCE

1. To ensure the lifetime of the product, **ALWAYS** clean it after each use, using a stiff bristled brush
2. **ALWAYS** thoroughly dry the water tank before storing it for any length of time.
3. **ALWAYS** store in a frost free environment.
4. **ALWAYS** check fittings and materials regularly for any damage or leaks.
5. The water tank is made of ripstop PVC. If a rip does appear, this can be mended with the repair patch. **ALWAYS** test the adhesive on a small section of the repair patch before use, as some adhesives will damage/melt the material of the water tank.

A SELECTION FROM THE VAST RANGE OF

Clarke®

QUALITY PRODUCTS



AIR COMPRESSORS

From DIY to industrial, Plus air tools, spray guns and accessories.

GENERATORS

Prime duty or emergency standby for business, home and leisure.

POWER WASHERS

Hot and cold, electric and engine driven - we have what you need

WELDERS

Mig, Arc, Tig and Spot. From DIY to auto/industrial.

METALWORKING

Drills, grinders and saws for DIY and professional use.

WOODWORKING

Saws, sanders, lathes, mortisers and dust extraction.

HYDRAULICS

Cranes, body repair kits, transmission jacks for all types of workshop use.

WATER PUMPS

Submersible, electric and engine driven for DIY, agriculture and industry.

POWERTOOLS

Angle grinders, cordless drill sets, saws and sanders.

STARTERS/CHARGERS

All sizes for car and commercial use.

**PARTS & SERVICE:
0208 988 7400**

Parts Enquiries
Parts@clarkeinternational.com

Servicing & Technical Enquiries
Service@clarkeinternational.com

SALES: UK 01992 565333 or Export 00 44 (0)1992 565335

Clarke INTERNATIONAL Hemnall Street, Epping, Essex CM16 4LG
www.clarkeinternational.com