

CORNING

ROC™ Drop and SST-Drop™ Cable Access Guide

004-154-AEN, Issue 2

related literature | Search www.corning.com/opcomm. Click on “Resources/Standard Recommended Procedures.”

1. General

This document describes the procedure for prepping and stripping of ROC™ Drop and SST-Drop™ cables.

ROC™ Drop Cables

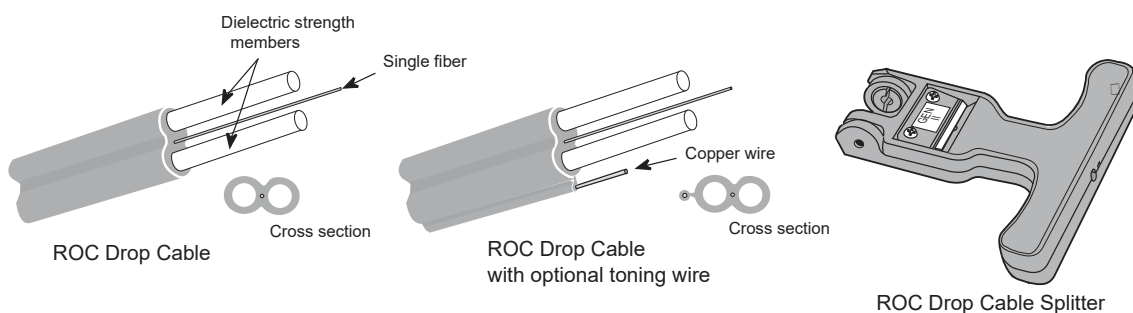

not to scale

SST-Drop™ Cables

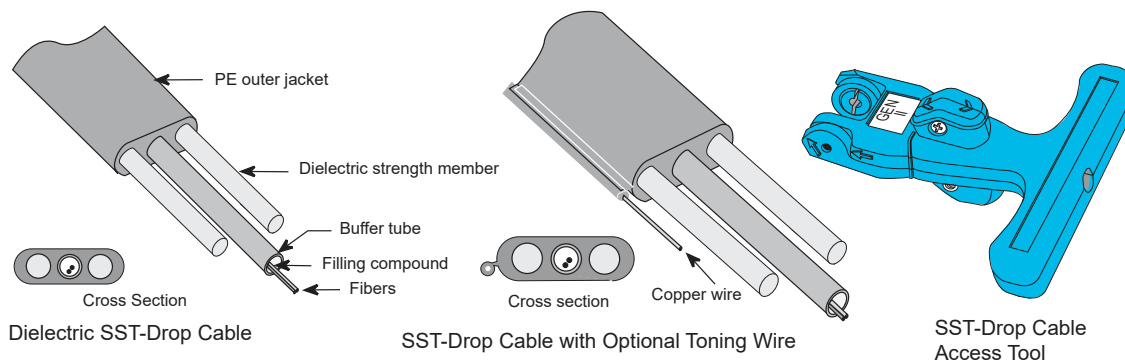

not to scale

HPA-0001B

Table of Contents

1. General	1
2. Precautions	3
2.1. Safety Glasses	3
2.2. Safety Gloves	3
2.3. Chemical Precautions	3
2.4. Laser Handling Precautions	3
2.5. Cable Handling Precautions.	3
3. ROC™ Drop Cable Access	4
3.1. Tools and Materials	4
3.2. Cable-end Preparation	4
3.3. Separating a ROC Drop Cable Optional Toning Wire	4
3.4. Shaving the Narrow Sides of the Cable Jacket	5
3.5. Shaving the Wide Sides of the Cable Jacket	6
3.6. GRP Strength Member Separation	7
3.7. Accessing the Fiber	7
3.8. Hardware Placement	8
4. SST-DROP™ Cable Access	9
4.1. Tools and Materials	9
4.2. Cable Preparation	9
4.3. Separating an SST-Drop Cable Optional Toning Wire	9
4.4. Jacket Removal	10
4.5. Accessing the Fiber	11
4.6. Cold Weather Buffer Tube Access	13
4.7. Hardware Placement	13

2. Precautions

2.1 Safety Glasses



CAUTION: Recommend the use of safety glasses (spectacles) conforming to ANSI Z87, for eye protection from accidental injury when handling chemicals, cables, or working with fiber. Pieces of glass fiber are very sharp and have the potential to damage the eye.

2.2 Safety Gloves



CAUTION: The wearing of cut-resistant safety gloves to protect your hands from accidental injury when using sharp-bladed tools and armored cable is strongly recommended. Use extreme care when working with severed armor. There will be a sharp edge where armor is cut. To minimize the chance of injury from the cut armor, cover the exposed edge with a wrap of electrical tape. To minimize the chance of injury from sharp-bladed tools, always cut away from yourself and others. Dispose of used blades and armor scrap properly.

2.3 Chemical Precautions



WARNING: Isopropyl alcohol is flammable with a flashpoint at 54°F. It can cause irritation to eyes on contact. In case of contact, flush eyes with water for at least 15 minutes. Inhalation of vapors irritates the respiratory tract. Exposure to high concentrations has a narcotic effect, producing symptoms of dizziness, drowsiness, headache, staggering, unconsciousness, and possibly death.

2.4 Laser Handling Precautions



CAUTION: Recommend the use of safety glasses (spectacles) conforming to ANSI Z87, for eye protection from accidental injury when handling chemicals, cables, or working with fiber. Pieces of glass fiber are very sharp and have the potential to damage the eye.



WARNING: DO NOT use magnifiers in the presence of laser radiation. Diffused laser light can cause eye damage if focused with optical instruments. Should accidental eye exposure to laser light be suspected, arrange for an eye examination immediately.



WARNING: Never look directly into the end of a fiber that may be carrying laser light. Laser light can be invisible and can damage your eyes. Viewing it directly does not cause pain. The iris of the eye will not close involuntarily as when viewing a bright light. Consequently, serious damage to the retina of the eye is possible. Should accidental eye exposure to laser light be suspected, arrange for an eye examination immediately.

2.5 Cable Handling Precautions



CAUTION: Fiber optic cable is sensitive to excessive pulling, bending, and crushing forces. Consult the cable specification sheet for the cable you are installing. Do not bend the cable more sharply than the minimum recommended bend radius. Do not apply more pulling force to the cable than specified. Do not crush the cable or allow it to kink. Doing so may cause damage that can alter the transmission characteristics of the cable; the cable may have to be replaced.

3. ROC™ Drop Cable Access

3.1 Tools and Materials

The following tools and materials are required to access a dielectric ROC™ Drop cable:

- ROC Drop cable splitter (catalog number RDST-000)
- Vinyl electrical tape
- Tape measure
- Lint-free tissues
- Scissors
- Diagonal cutting pliers (side cutters)
- *For cables with an optional toning wire you will also need:*
- Cable sheath knife or utility knife with straight blade
- Emery cloth (optional)

3.2 Cable-end Preparation

Refer to the documentation for the hardware in which you are installing the cable for the recommended sheath removal lengths. Mark the cable at the appropriate distance from the cable end with a wrap of electrical tape. If the cable you are installing does not have an optional toning wire, skip to Step 3.4

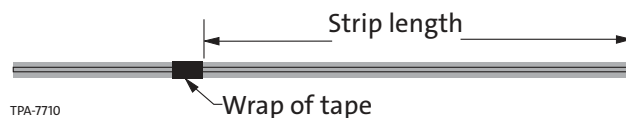

3.3 Separating a ROC Drop Cable Optional Wire

NOTE: The majority of ROC Drop cables shipped with optional toning wires have 12-15 inches (30.5 - 38.1 cm) of the jacketed copper component already separated, looped, and secured by tape to the side of the optical cable.

Prior to accessing the fiber or placing the cable in a splice closure, the optional toning wire must be separated from the optical portion of the cable.

IMPORTANT: Do NOT cut off the toning wire at this time — merely separate it from the optical cable.

IMPORTANT: Termination, grounding, and bonding of the toning wire should be performed in accordance with local codes, ordinances, and practices.

Step 1: Determine the point on the cable where the separation between the toning wire and cable must occur. Be certain the separation begins outside the splice closure or hardware.

Step 2: Determine the point on the cable where the separation between the toning wire and cable must occur. Be certain the separation begins outside the splice closure or hardware.

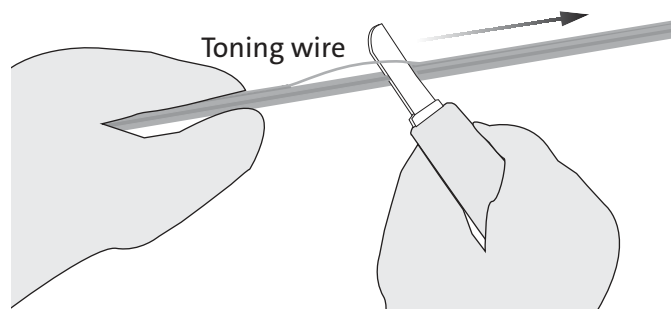

To store the toning wire for later use:

- Step 1:** Place a piece of electrical tape over the end of the wire.
- Step 2:** Place an additional wrap of tape around the entire cable at the start of the separation point to prevent further splitting of the web.
- Step 3:** Coil the toning wire and secure the coils to the cable with a wrap of electrical tape.

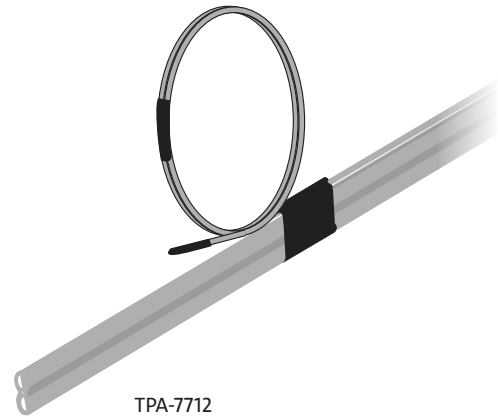

Web-remnant Removal

Using the cable sheath knife or a utility knife, followed by sanding with an emery cloth, remove any web remnants on the cable in the area(s) that will be sealed in any closure or hardware.

If accessing the copper toning wire is necessary, use a standard wire stripper and strip off the required length of jacket material.

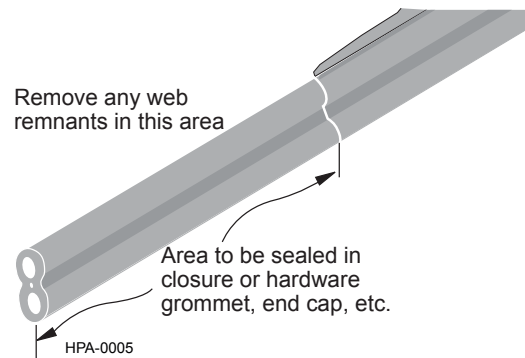

3.4 Shaving the Narrow Sides of the Cable Jacket

- Step 1:** Open the tool and place the cable in the vertical slot (the slot marked #1 on the tool) so that the electrical tape wrap applied in Step 3.2 is just behind the blades, i.e., opposite the T-handle side of the blades.

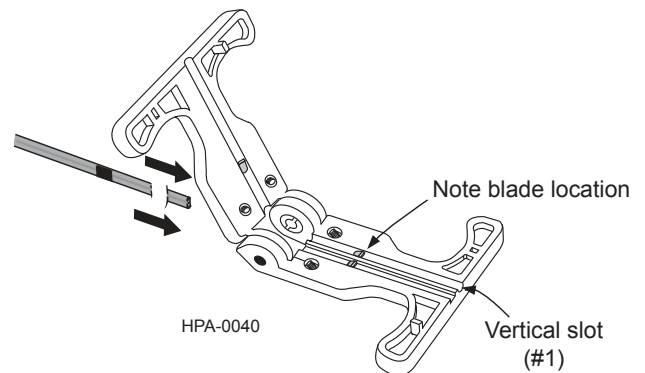

- Step 2:** Close the tool. Make sure that the cable is in the vertical slot and that the splitting tool is fully closed.

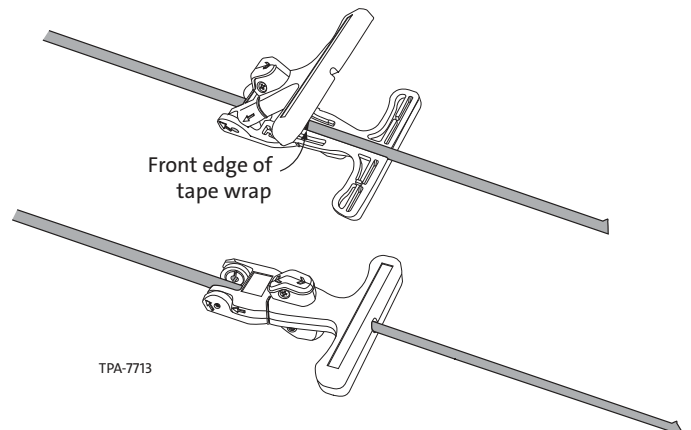

Step 3: Firmly hold the cable with one hand and pull the tool along the cable with your other hand until the tool is clear of the end of the cable. The tool should pull smoothly and with very little effort. If you have difficulty in pulling the tool, make sure the cable is properly positioned in the tool.

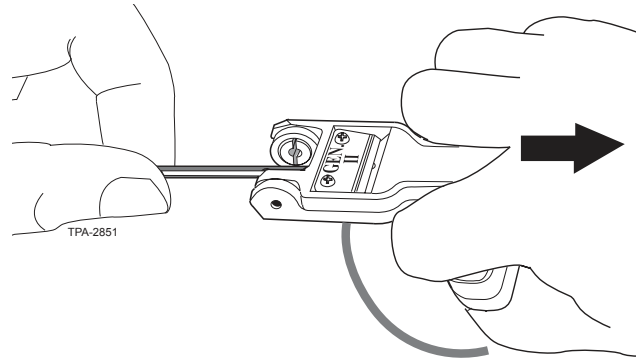

3.5 Shaving the Wide Sides of the Cable Jacket

NOTE: Unlike the vertical slot which shaves jacket material from both narrow sides of the cable at the same time, the ROC™ Drop Splitting Tool shaves only one wide-side of the cable jacket at a time.

Step 1: Open the tool and feed approximately 3 inches (8 cm) of the cable past the blade in the horizontal (#2) slot of the tool.

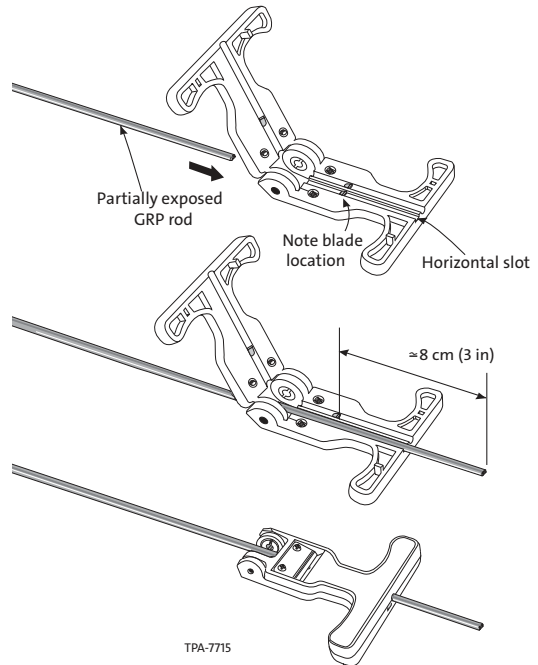

Step 2: Close the tool. Make sure that the cable is in the horizontal slot and that the splitting tool is fully closed.

Step 3: Close the tool. Make sure that the cable is in the horizontal slot and that the splitting tool is fully closed.

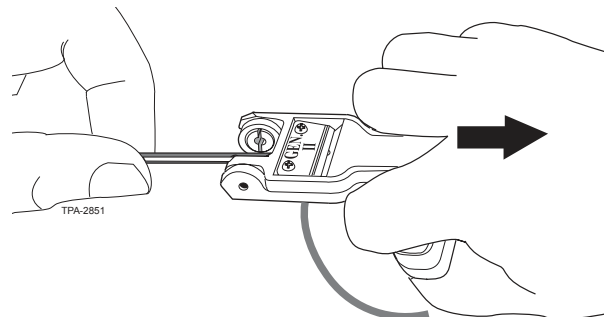

Step 4: Flip the cable over and repeat Steps 1 through 3 to shave 3 inches (8 cm) of jacket from the other wide side of the cable. The 3 inches at the end of the cable should resemble this illustration.

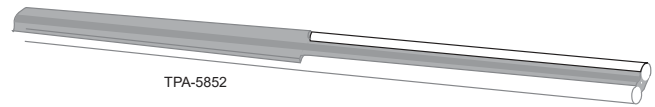

3.6 GRP Strength Member Separation

Step 1: Separate the GRP strength members from the cable back to the strip length tape wrap.

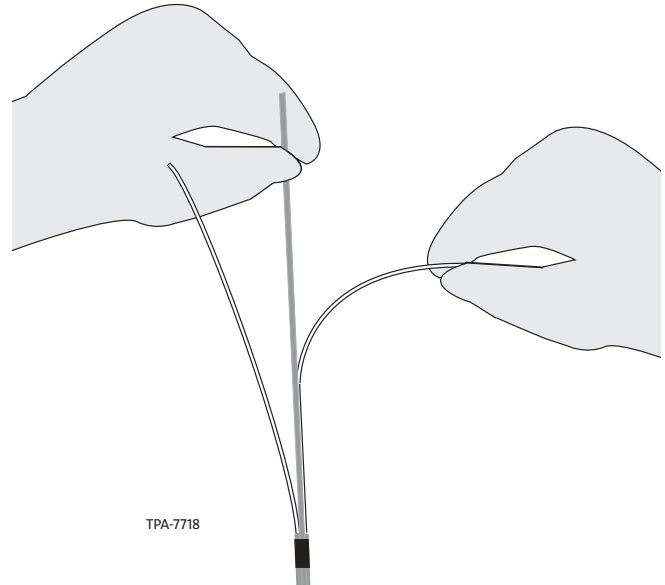

Step 2: Use diagonal cutting pliers (side cutters) or scissors to cut the GRP rods strength member as close as possible to the tape wrap.

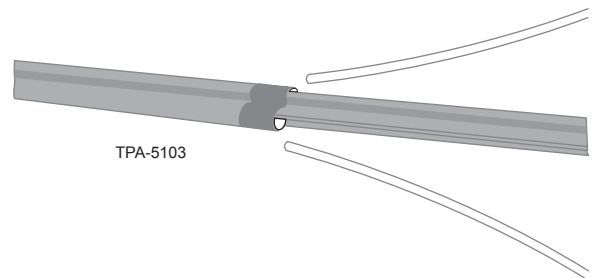

3.7 Accessing the Fiber

Step 1: Use scissors to cut the cable end square just past the three inch section of cable which had its wide sides removed in Step 3.5.

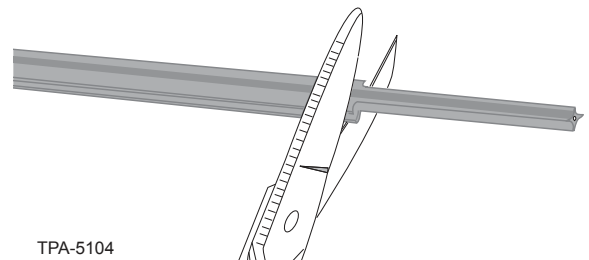

Step 2: Use scissors to make a cut approximately 1.0 to 1.5 inches (2.5 - 3.7 cm) long between the grooves where the strength members were previously located.

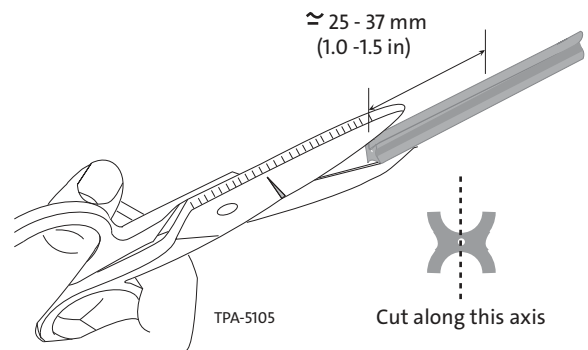

Step 3: Firmly hold each half of the cable jacket and pull to separate the center section of cable sheath back to the strip length tape wrap.

It is best to pull each half at a slight angle relative to the cable direction as opposed to bending each half over approximately 90 degrees to the cable and then pulling.

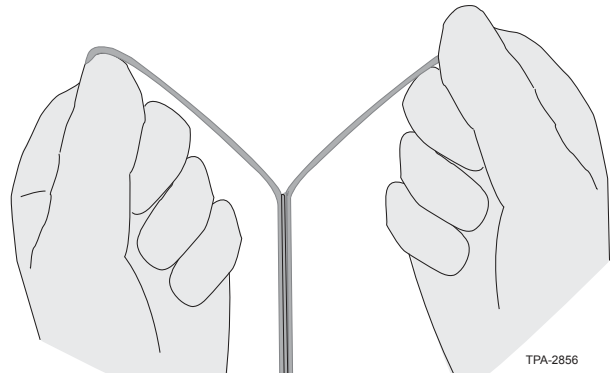

Step 4: Once the sheath has been separated along the entire length, look for the colored fiber (blue is standard). It may still be attached to one half of the sheath, or it may have separated as the sheath was split.

If the fiber is still attached to the sheath, look for it at the cable end. Separate the fiber from the sheath and gently pull the fiber along the length to where it leaves the cable at the end near the cut strength members.

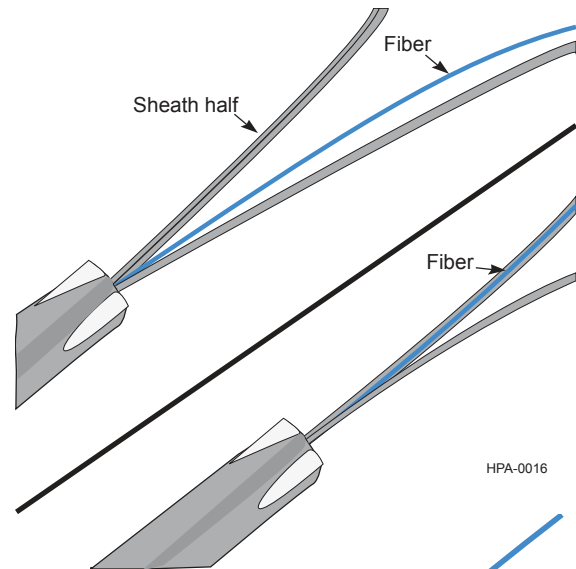

Step 5: Using care not to damage or cut the fiber, cut off and discard the split center sheath segments. The fiber is now exposed and both the cable and fiber are ready to be placed into the hardware for your specific application.

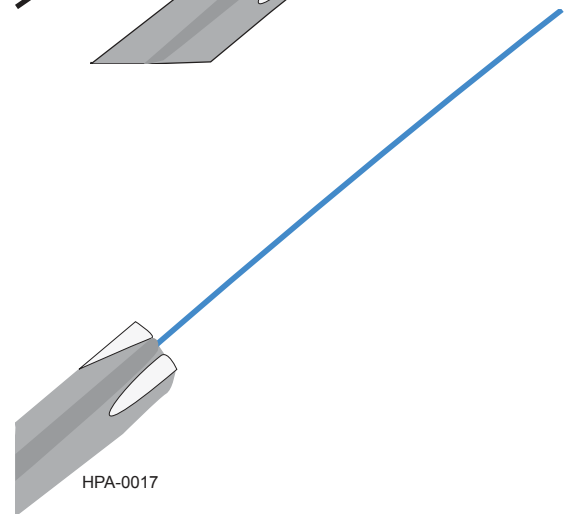

3.8 Hardware Placement

Step 1: Route and secure the ROC™ Drop cable into the selected termination hardware, following all hardware instructions. **BE EXTREMELY CAREFUL NOT TO DAMAGE THE EXPOSED FIBER DURING THIS STEP.**

Step 2: Terminate or splice the fiber according to the appropriate procedures.

4. SST-Drop™ Cable Access

IMPORTANT: Please see Section 2 of this guide for precautions

4.1 Tools and Materials

The following tools and materials are required to access an SST™ Drop cable:

- SST-Drop Cable Access Tool (p/n FDST-000)
- Diagonal cutting pliers (side cutters)
- Vinyl electrical tape
- Tape measure
- Fiber-Clean® Towelettes (wipes)
- Scissors
- Ideal coaxial cable stripper*
- Small screwdriver
- Lint free tissues

For cables with an optional toning wire you will also need:

- Cable sheath knife or utility knife with straight blade
- Emery cloth (optional)

For extreme cold weather tube access:

- Baby powder
- 2.7 - 3.0 mm tube splitter (red) (p/n A0362957)

4.2 Cable Preparation

Refer to the documentation for the hardware in which you are installing the cable for the recommended sheath removal lengths. Mark the cable at the appropriate distance from the cable end with a wrap of electrical tape.

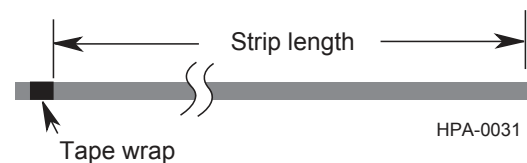

NOTE: If the cable you are installing does not have an optional toning wire, skip to Section 4.4.

4.3 Separating an SST-Drop Cable Optional Toning Wire

The majority of cables shipped with optional toning wires have 12 to 15 inches (30.5 cm to 38 cm) of the jacketed copper component already separated, looped, and secured by tape to the side of the optical cable. Whenever an additional length of toning wire is needed for grounding purposes, cut the web along the entire additional length and separate the two cable components.

Prior to accessing the fibers or placing the cable in a splice closure, the optional toning wire must be separated from the optical portion of the cable.

IMPORTANT: Do NOT cut off the toning wire at this time - merely separate it from the optical cable.

IMPORTANT: Termination, grounding, and bonding of the toning wire must be performed in accordance with local codes, ordinances, and practices.

To separate the toning wire in cable-end applications:

Step 1: Determine the point on the cable where the separation between the toning wire and cable must occur. Be certain the separation begins outside the splice closure or hardware.

Step 2: Holding the cable in one gloved hand with the toning wire facing up, use a cable sheath knife to separate the toning wire - only light pressure is needed to cut the web. Cut with the blade tilted toward the cable to minimize the left-over web material on the cable.

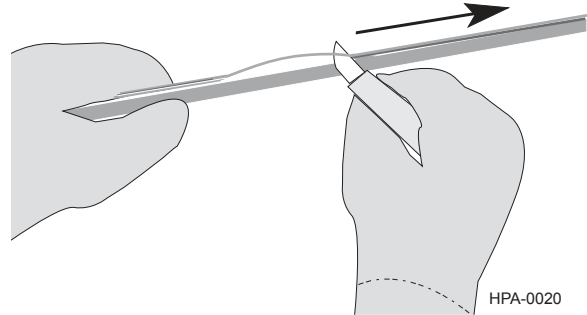

To store the toning wire for later use:

Step 1: Place a piece of electrical tape over the end of the wire.

Step 2: Place an additional wrap of tape around the entire cable at the start of the separation point to prevent further splitting of the web.

Step 3: Coil the toning wire and secure the coils to the cable with a wrap of electrical tape.

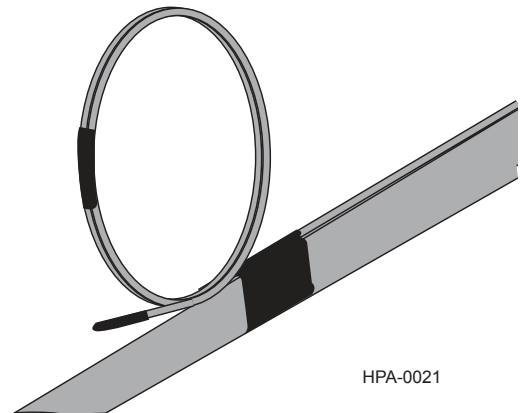

4.4 Jacket Removal

Step 1: Open the tool and insert the cable so that the tape wrap applied in Step 3.2 is just behind the blades.

Step 2: Close the tool.

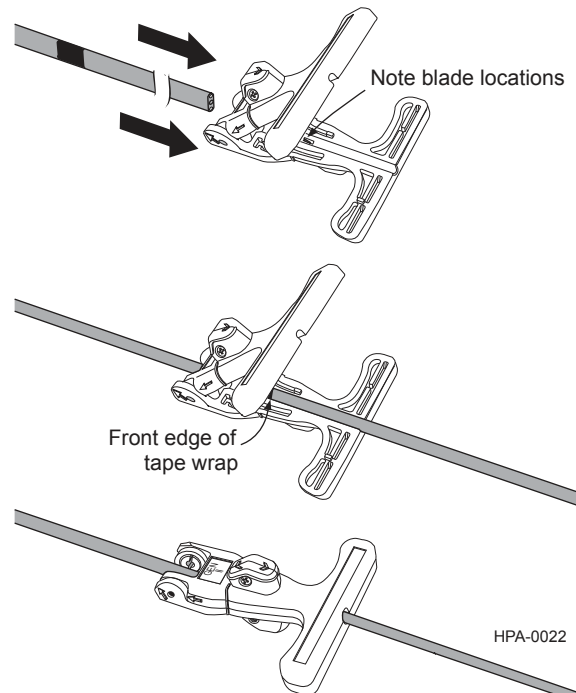

Step 3: Firmly hold the cable with one hand and use your other hand to pull the tool along the cable until the tool is clear of the end of the cable.

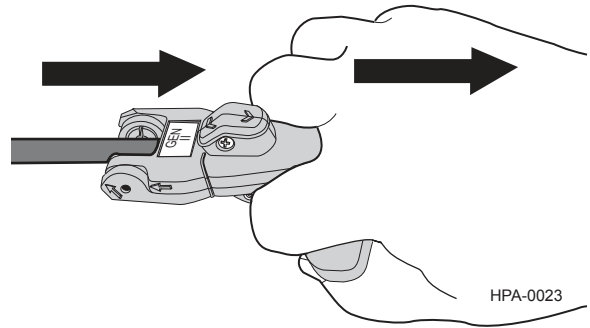

Step 4: Use scissors to remove the split sections of the cable jacket and to cut the strength members as flush as possible to the cable jacket. Use care to avoid damaging the buffer tube.

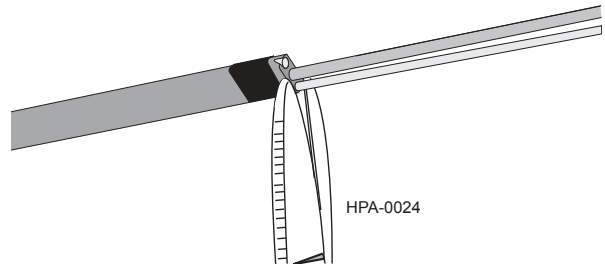

4.5 Accessing the Fiber

NOTE: At extremely cold temperature, the buffer tube filling compound (gel) becomes MORE viscous (thick and sticky) and an alternate method of accessing the buffer tube may be required. This cold weather procedure is described in Section 4.6.

NOTE: In cables containing more than 12 fibers, the standard color code with fiber ring markings identify fibers numbered 13-24.

Fiber coloring
1-12: blue, orange, green, brown, slate, white, red, black, yellow, violet, rose, aqua
13-24 (all with one black ring mark): blue, orange, green brown, slate, white, red, natural, yellow, violet, rose, aqua

Step 1: Before using the stripper, make sure that it is properly adjusted. Use a small screwdriver to adjust one of the blades on the side of the buffer tube cutter so that it seats against the lower jaw but does not force the jaw open.

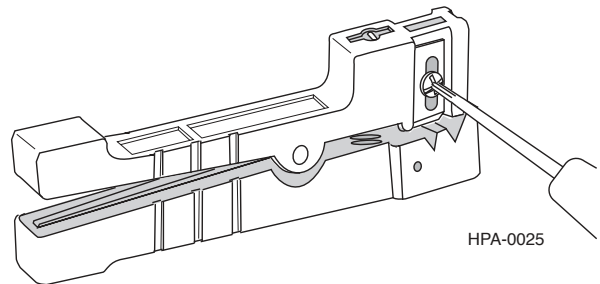

Leave the blades on the front and other side of the tool fully retracted so that they do not extend into the grooves of the lower jaw.

Step 2: Use the last 2 to 3 inches (5 to 8 cm) of the buffer tube to determine the effectiveness of the stripper's blade and how many turns of the tool will be required to score the tube.

To minimize damage to the fibers inside the tube, always use the tool to score the tube, rather than ring-cut it.

Step 3: To score the buffer tube:

- a. Open the tool by squeezing its handles together and place the stripper's blade on the buffer tube at the desired scoring point.
- b. Hold the buffer tube steady with one hand to prevent it from twisting.
- c. Use your other hand to rotate the tool around the buffer tube two to three complete turns to score it.

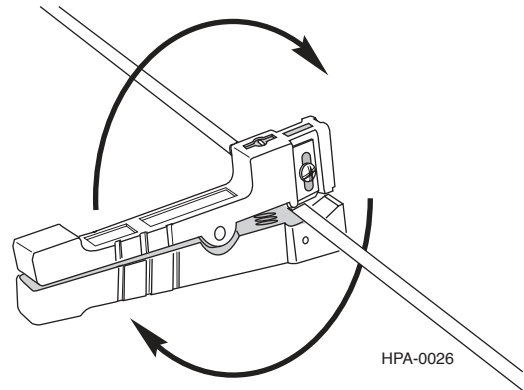

Step 4: Remove the tool from the buffer tube. If the stripper completely cuts through the tube during this trial step, move the tool to a new trial area at the end of the buffer tube and repeat Step 3 with fewer rotations in Step 3c. If the blade cuts completely through the tube, damage to the fibers inside can result.

Step 5: Carefully flex the tube to break it at the score point. The break should be clean and free of rough edges. If the break is not clean, move the tool to a new trial area at the end of the buffer tube and repeat Step 3 with an additional rotation or two in Step 3c.

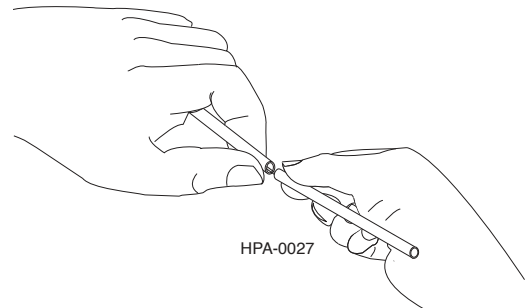

Step 6: Slide the severed section of buffer tube off of the fibers. **USE CARE TO AVOID DAMAGING THE FIBERS.**

Step 7: Once you have determined the number of rotations needed to score the tube, place the tool at the actual scoring point and repeat Steps 3 through 6.

CAUTION: When cleaning the fibers, clean along the length of the fiber without imparting any severe bends over the fibers such as over fingers.

Step 8: Make at least three passes with a Fiber-Clean wipe to clean the fibers. More than three passes may be required.

Step 9: After the filling compound has been removed, make at least three passes with a lint-free tissue soaked with alcohol.

4.6 Cold Weather Buffer Tube Access

Use the red tube splitting tool (p/n A0362957) to split the buffer tube as follows:

Step 1: Open the tube splitting tool and place it around the buffer tube at the start of the desired access point. Close the tool.

Step 2: Pull the tool in the desired direction until the end of the desired cut is reached.

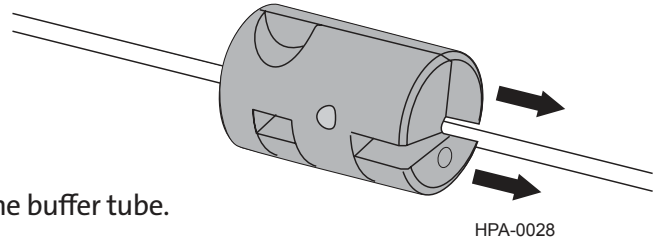

Step 3: Open the tube splitter and remove it from the buffer tube.

CAUTION: At extremely cold temperatures, the filling compound (gel) becomes tacky. Take great care in separating the two buffer tube halves since the fiber will stick to both halves.

Step 4: Separate the two buffer tube halves carefully.

Step 5: Cut away the buffer tubes halves using scissors or make a ring cut with the coaxial stripper.

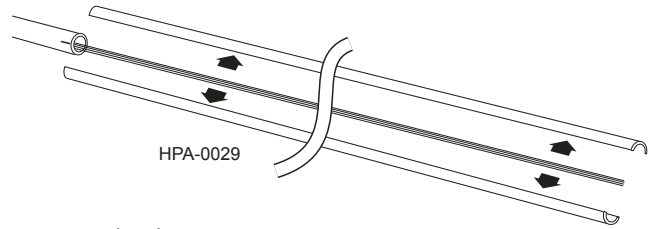

CAUTION: At extremely cold temperatures, the filling compound (gel) becomes tacky. Take great care in separating the two buffer tube halves since the fiber will stick to both halves.

Step 6: Make at least three passes with a Fiber-Clean wipe to clean the fibers. More than three passes may be required.

Step 7: After the filling compound has been removed, make at least three passes with a lint-free tissue soaked with alcohol.

Step 8: In extremely cold weather (14° F [10° C] and below), it is especially important to ensure that the fibers are clean if they are to be installed into a fan-out kit or furcation tubing. Placing baby powder on the fiber will reveal any places on the fiber that contain filling compound residue.

4.7 Hardware Placement

Step 1: Route and secure the drop cable into the selected termination hardware, following all hardware instructions. **BE EXTREMELY CAREFUL NOT TO DAMAGE THE EXPOSED FIBERS DURING THIS STEP.**

Step 2: Terminate or splice the individual fibers according to the appropriate procedures.