

Owner's Manual/Manual Del Propietario



1/2 HP

315_{MHz} GARAGE DOOR OPENER

ABRIDOR DE PUERTA DE COCHERA 315_{MHz}

For Residential Use Only

Model • 139.53930D

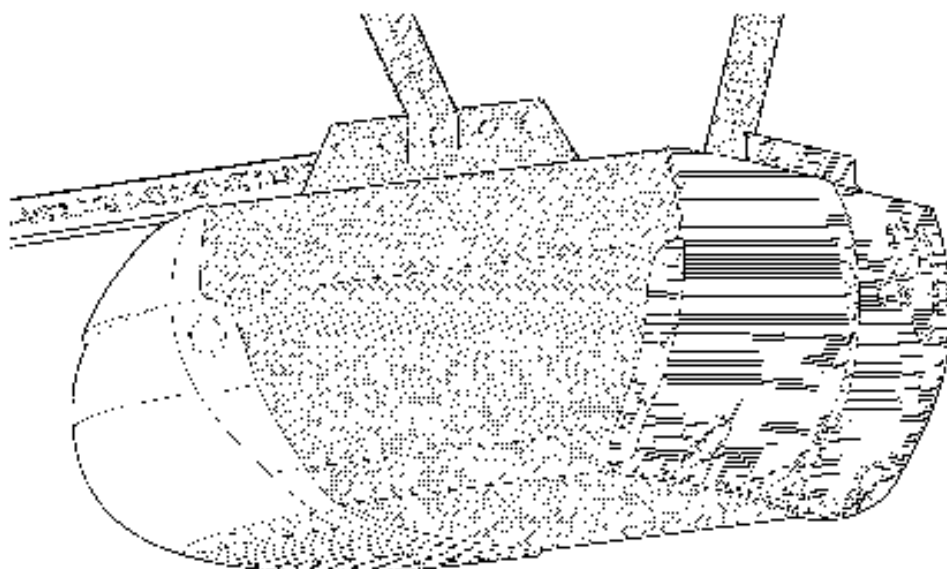

Read and follow all safety rules and operating instructions before first use of this product.

Fasten the manual near the garage door after installation.

Periodic checks of the opener are required to ensure safe operation.

Leer y seguir todas las reglas de seguridad y las instrucciones de operación antes de usar este producto por primera vez.

Guardar este manual cerca de la puerta de la cochera.

Se deben realizar revisiones periódicas del abridor de puertas para asegurar su operación segura.



Sears, Roebuck and Co., Hoffman Estates, IL 60179 U.S.A
www.sears.com/craftsman

ENGLISH ESPAÑOL

TABLE OF CONTENTS

Introduction	2-7	Adjustment	27-29
Safety symbol and signal word review	2	Adjust the travel limits	27
Preparing your garage door	3	Adjust the force	28
Tools needed	3	Test the safety reversal system	29
Planning	4-5	Test The Protector System®	29
Carton inventory	6	Operation	30-34
Hardware inventory	7	Operation safety instructions	30
Assembly	8-11	Using your garage door opener	30
Assemble the rail and install the trolley	8	Using the wall-mounted Door Control	31
Fasten the rail to the motor unit	9	To open the door manually	31
Install the idler pulley	9	Care of your garage door opener	32
Install the chain/cable	10	Having a problem?	33
Tighten the chain	11	Diagnostic chart	34
Installation	11-26	Programming	35-36
Installation safety instructions	11	To add or reprogram a hand-held remote control	35
Determine the header bracket location	12	To erase all codes	35
Install the header bracket	13	3-Function Remotes	35
Attach the rail to the header bracket	14	To add, reprogram or change a Keyless Entry PIN	36
Position the opener	15	Repair Parts	37-38
Hang the opener	16	Rail assembly parts	37
Install the door control	17	Installation parts	37
Install the light	18	Motor unit assembly parts	38
Attach the emergency release rope and handle	18	Accessories	39
Electrical requirements	19	Warranty	39
Install The Protector System®	20-22	Repair Parts and Service	Backcover
Fasten the door bracket	23-24		
Connect the door arm to the trolley	25-26		

INTRODUCTION

Safety Symbol and Signal Word Review

This garage door opener has been designed and tested to offer safe service provided it is installed, operated, maintained and tested in strict accordance with the instructions and warnings contained in this manual.



Mechanical



Electrical



When you see these Safety Symbols and Signal Words on the following pages, they will alert you to the possibility of **serious injury or death** if you do not comply with the warnings that accompany them. The hazard may come from something mechanical or from electric shock. Read the warnings carefully.

When you see this Signal Word on the following pages, it will alert you to the possibility of damage to your garage door and/or the garage door opener if you do not comply with the cautionary statements that accompany it. Read them carefully.

Preparing your garage door

Before you begin:

- Disable locks.
- Remove any ropes connected to garage door.
- **Complete the following test** to make sure your garage door is balanced and is not sticking or binding:
 1. Lift the door about halfway as shown. Release the door. If balanced, it should stay in place, supported entirely by its springs.
 2. Raise and lower the door to see if there is any binding or sticking.

If your door binds, sticks, or is out of balance, call a trained door systems technician.

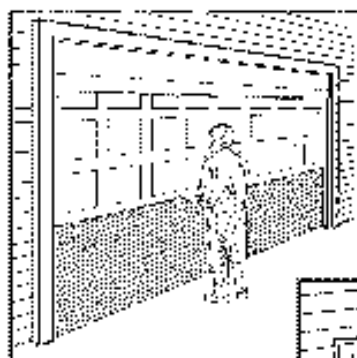

Sectional Door

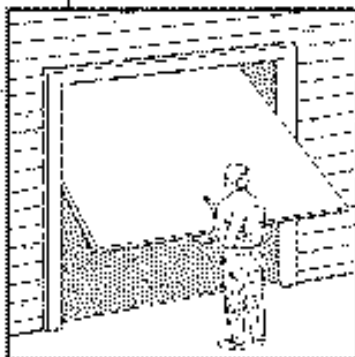

One-Piece Door

WARNING

To prevent possible SERIOUS INJURY or DEATH:

- ALWAYS call a trained door systems technician if garage door binds, sticks, or is out of balance. An unbalanced garage door may not reverse when required.
- NEVER try to loosen, move or adjust garage door, door springs, cables, pulleys, brackets or their hardware, all of which are under EXTREME tension.
- Disable ALL locks and remove ALL ropes connected to garage door BEFORE installing and operating garage door opener to avoid entanglement.

CAUTION

To prevent damage to garage door and opener:

- ALWAYS disable locks BEFORE installing and operating the opener.
- ONLY operate garage door opener at 120V, 60 Hz to avoid malfunction and damage.

Tools needed

During assembly, installation and adjustment of the opener, instructions will call for hand tools as illustrated below.

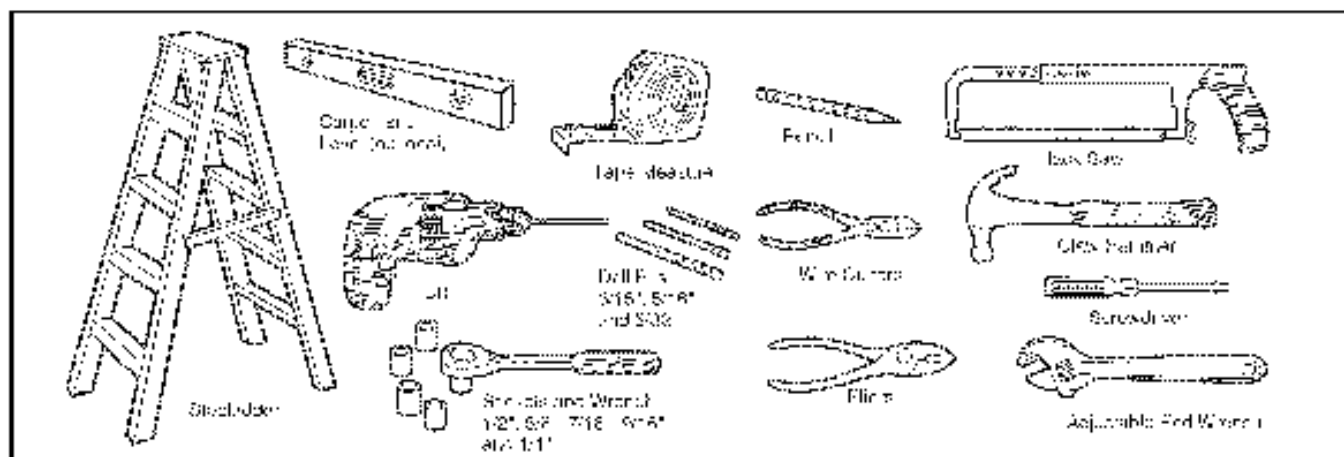

Planning (Continued)

ONE-PIECE DOOR INSTALLATIONS

- Generally, a one-piece door does not require reinforcement. If your door is lightweight, refer to the information relating to sectional doors in Installation Step 11.
- Depending on your door's construction, you may need additional mounting hardware for the door bracket (Step 11).

WARNING

Without a properly working safety reversal system, persons (particularly small children) could be **SERIOUSLY INJURED** or **KILLED** by a closing garage door.

- The gap between the bottom of the garage door and the floor **MUST NOT** exceed 1/4" (6 mm). Otherwise, the safety reversal system may not work properly.
- The floor or the garage door **MUST** be repaired to eliminate the gap.

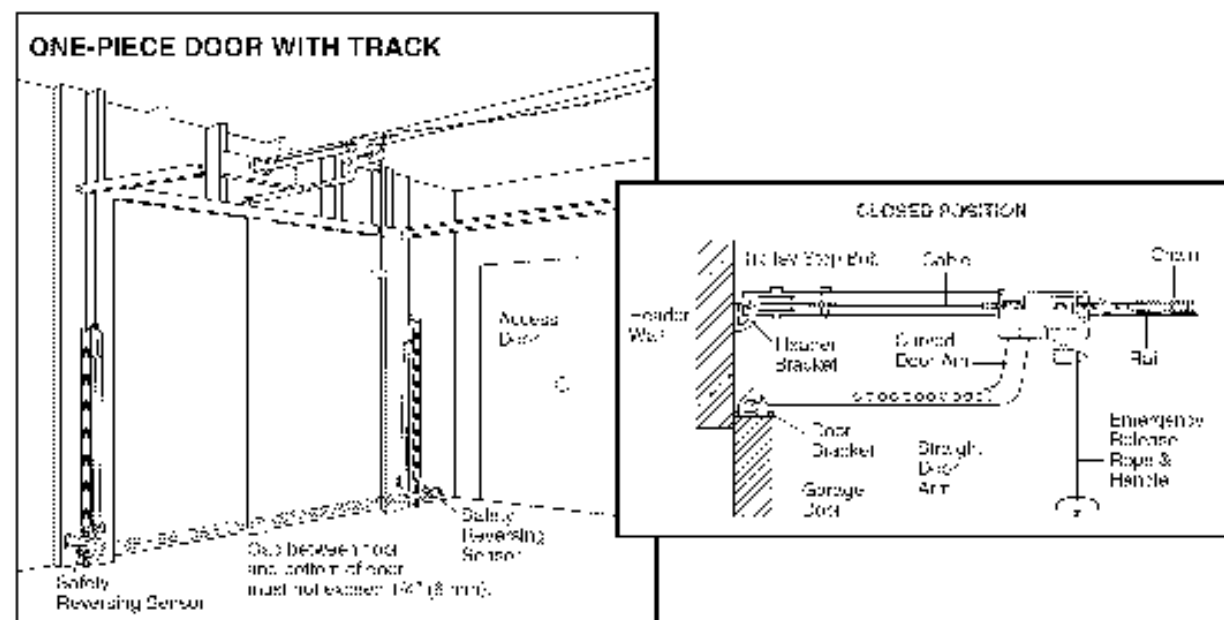
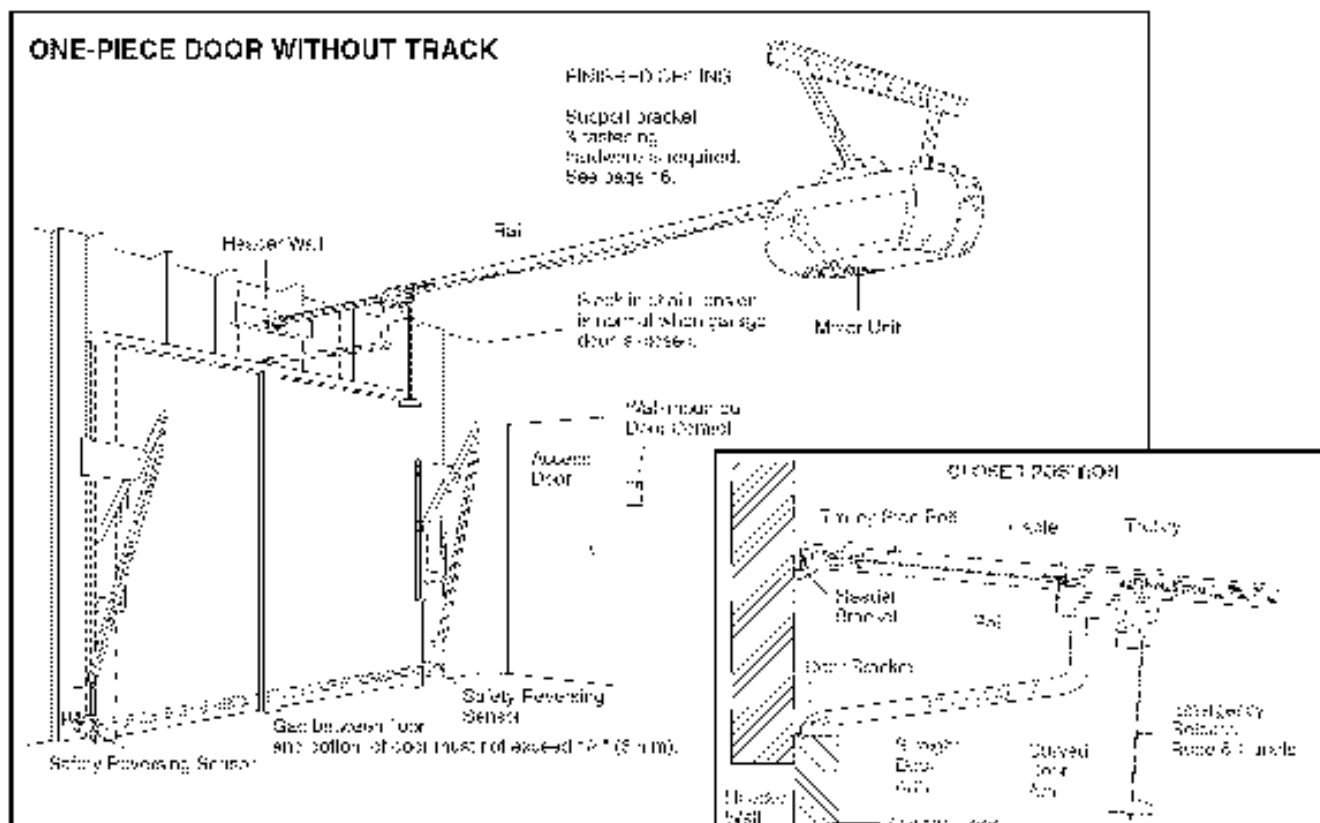

Carton Inventory

Your garage door opener is packaged in one carton which contains the motor unit and all parts illustrated below. Accessories will depend on the model purchased. If anything is missing, carefully check the packing

material. Parts may be stuck in the foam. Hardware for assembly and installation is shown on the next page. Save the carton and packing material until installation and adjustment is complete.

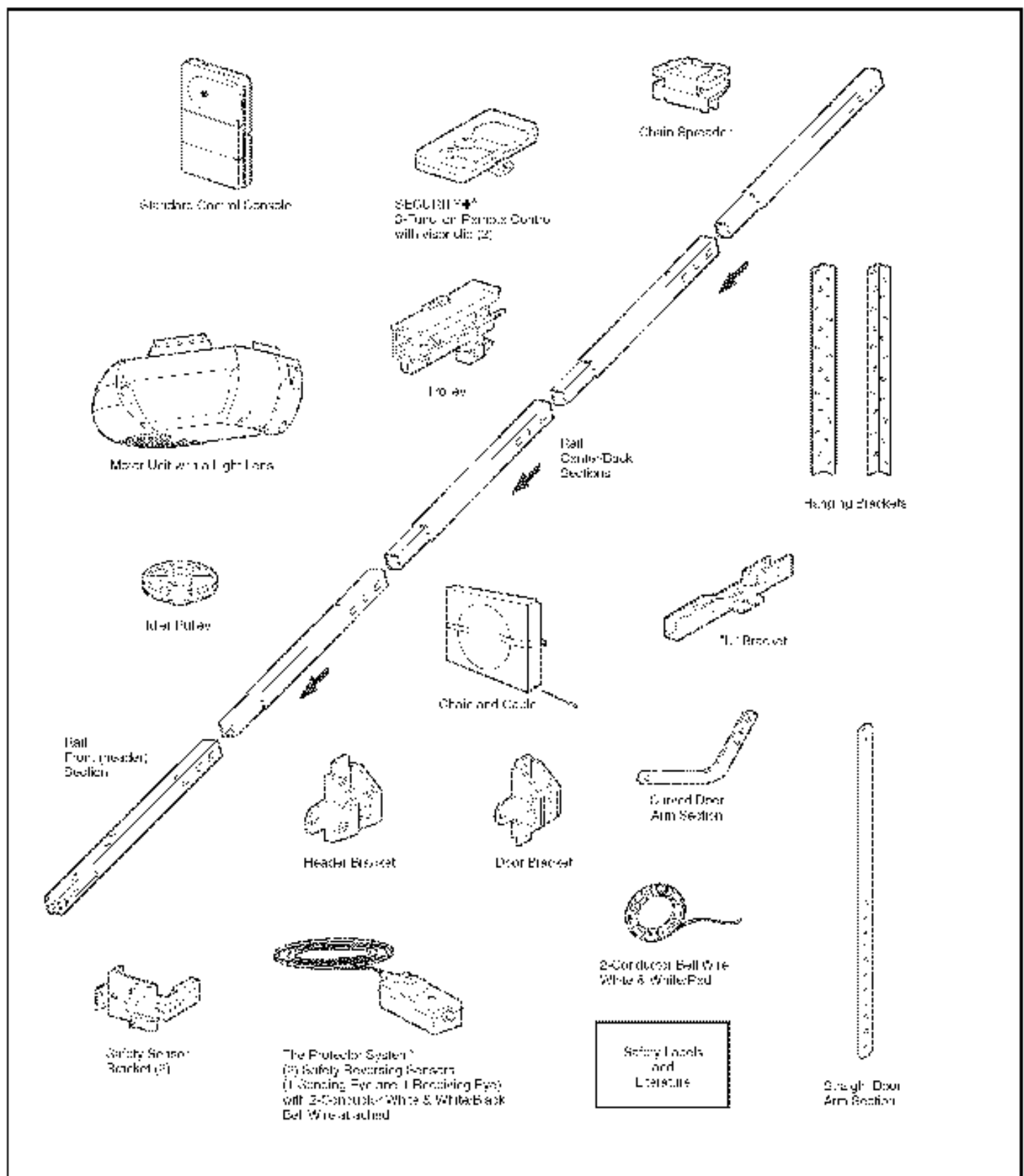

Hardware Inventory

Separate all hardware and group as shown below for the assembly and installation procedures.

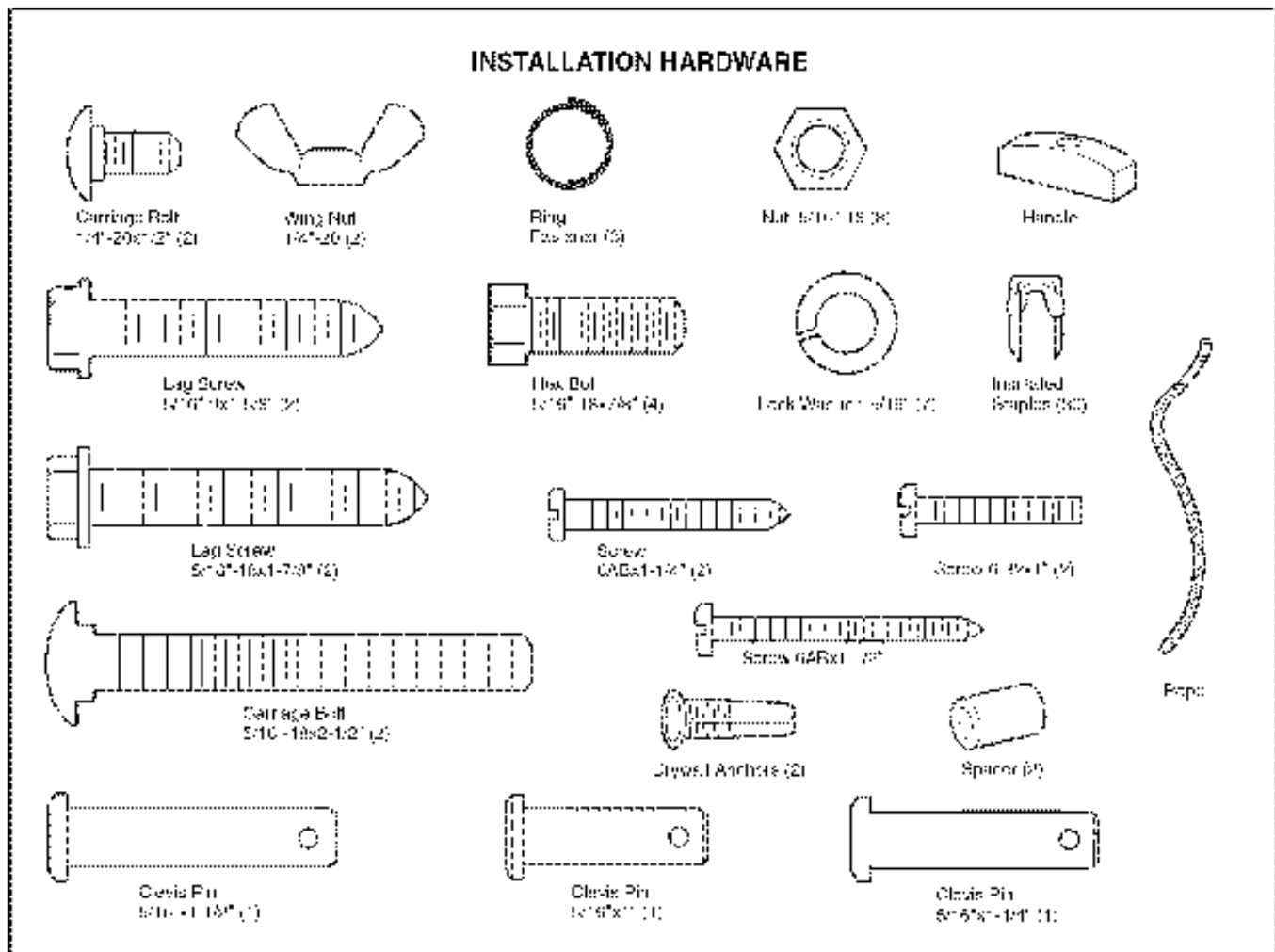
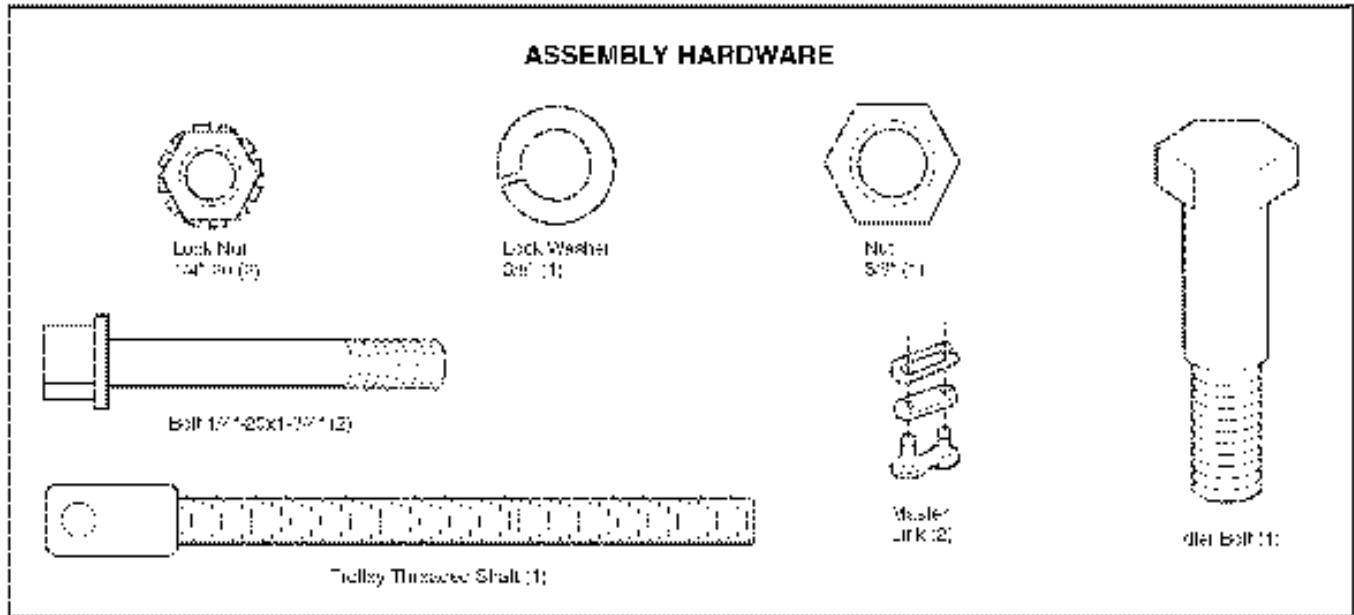

ASSEMBLY STEP 1

Assemble the Rail & Install the Trolley

To avoid installation difficulties, do not run the garage door opener until instructed to do so.

The front rail has a cut out "window" at the door end (see illustration). The hole above this window is larger on the top of the rail than on the bottom. A smaller hole 3-1/2" (8.9 cm) away is close to the rail edge. Rotate the back rail so it has a similar hole close to the opposite edge, about 4-3/4" (12 cm) from the far end.

1. Remove the straight door arm and hanging bracket packaged inside the front rail and set aside for Installation Step 5 and 12. **NOTE:** To prevent *INJURY* while unpacking the rail carefully remove the straight door arm stored within the rail section.
2. Align the rail sections on a flat surface as shown and slide the tapered ends into the larger ones. Tabs along the side will lock into place.

CAUTION

To prevent *INJURY* from pinching, keep hands and fingers away from the joints while assembling the rail.

3. Place the motor unit on packing material to protect the cover, and rest the back end of the rail on top. For convenience, put a support under the front end of the rail.
4. As a temporary stop, insert a screwdriver into the hole 10" (25 cm) from the front end of the rail, as shown.
5. Check to be sure there are 4 plastic wear pads inside the inner trolley. If they became loose during shipping, check all packing material. Snap them back into position as shown.
6. Slide the trolley assembly along the rail from the back end to the screwdriver.

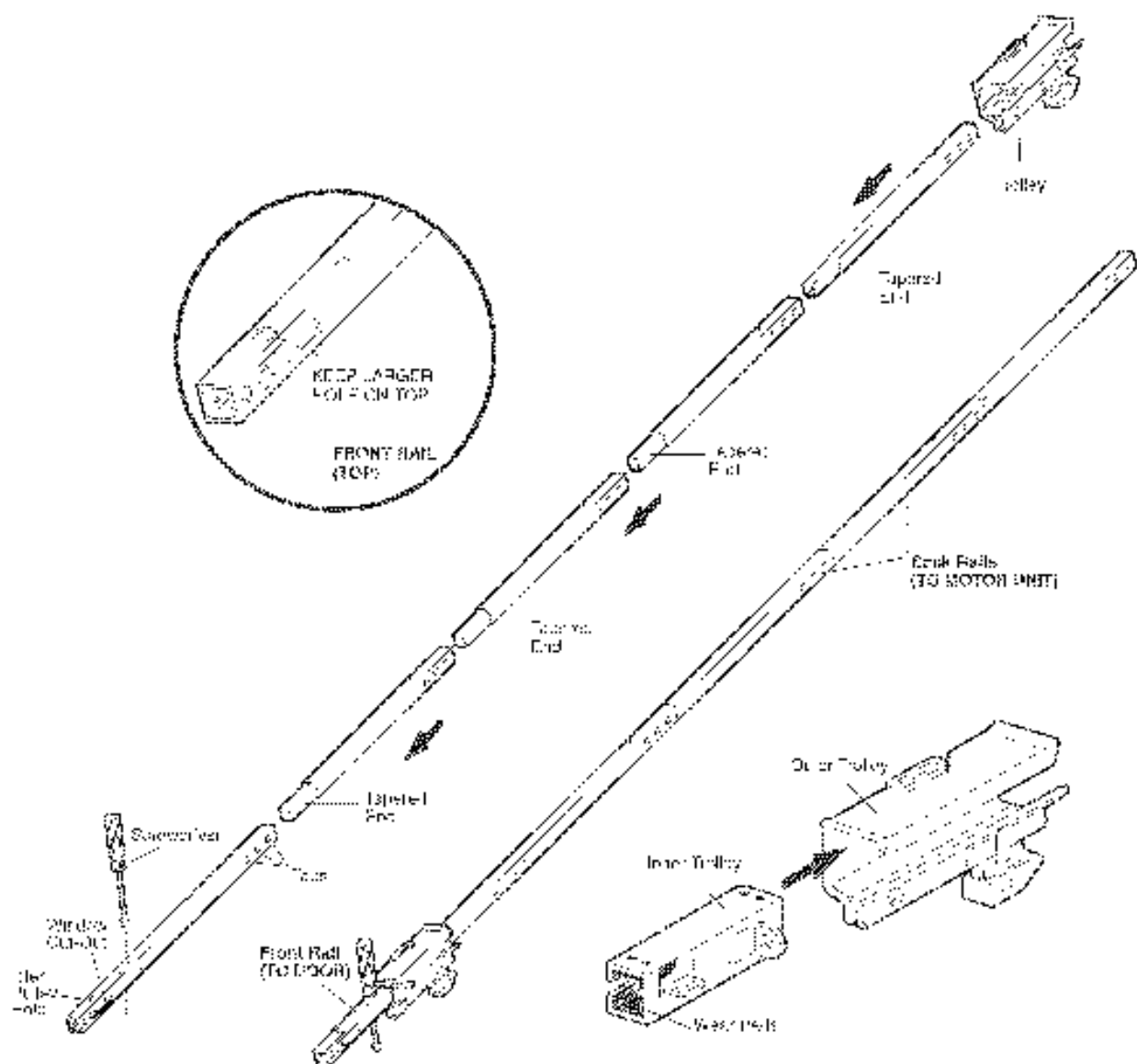

ASSEMBLY STEP 2

Fasten the Rail to the Motor Unit

- Insert a 1/4"-20x1-3/4 bolt into the cover protection bolt hole on the back end of the rail as shown. Tighten securely with a 1/4"-20 lock nut. *Do NOT overtighten.*
- Remove the two bolts from the top of the motor unit.
- Place the "U" bracket, flat side down onto the motor unit and align the bracket hole with the bolt holes. Fasten with the previously removed bolts.
- Align the rail assembly with the top of the motor unit. Slide the rail end onto the "U" bracket. *all the way to the stops that protrude on the top and sides of the bracket.*
- Attach spreader to the motor unit with two screws.

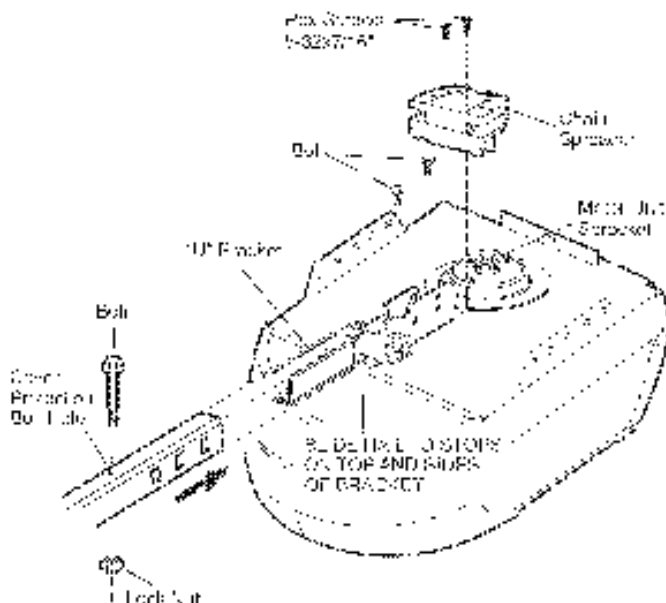
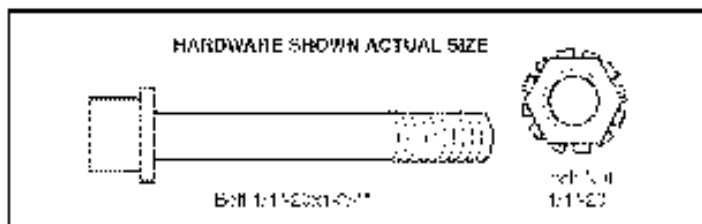

ASSEMBLY STEP 3

Install the Idler Pulley

- Lay the chain/cable beside the rail, as shown. Grasp the end of the cable and pass approximately 12" (30 cm) of cable through the window. Allow it to hang until Assembly Step 5.
- Remove the tape from the idler pulley. The inside center should be pre-greased. If dry, regrease to ensure proper operation.
- Place the idler pulley into the window as shown.
- Insert the idler bolt from the top through the rail and pulley. Tighten with a 3/8" lock washer and nut underneath the rail until the lock washer is compressed.
- Rotate the pulley to be sure it spins freely.
- Insert a 1/4"-20x1-3/4 bolt into the trolley stop hole in the front of the rail as shown. Tighten securely with a 1/4"-20 lock nut.

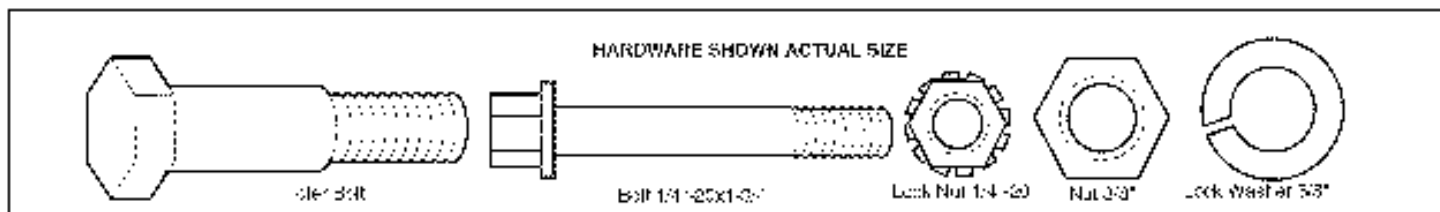
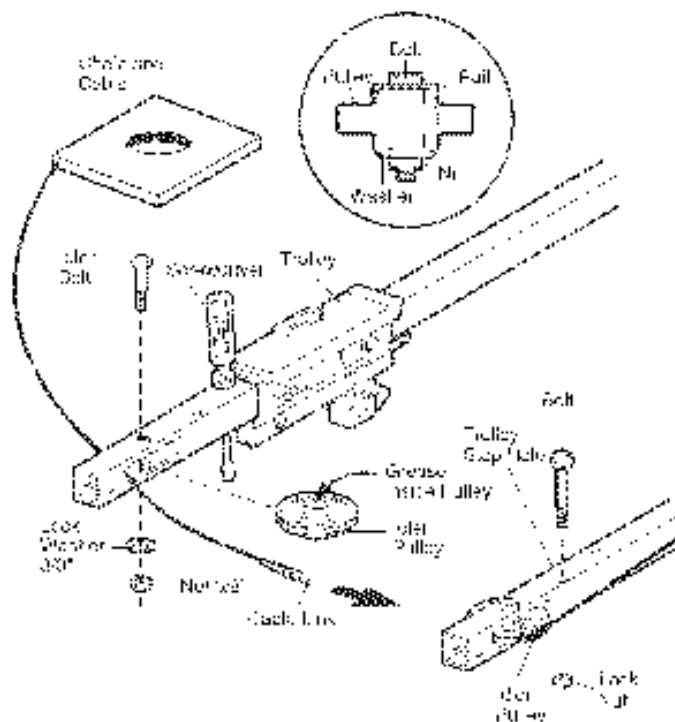

ASSEMBLY STEP 5

Tighten the Chain

- Spin the inner nut and lock washer down the trolley threaded shaft, away from the trolley.
- To tighten the chain, turn outer nut in the direction shown (Figure 1).
- When the chain is approximately 1/4" (6 mm) above the base of the rail at its midpoint, re-tighten the inner nut to secure the adjustment.

Sprocket noise can result if chain is too loose.

When installation is complete, you may notice some chain droop with the door closed. This is normal. If the chain returns to the position shown in Figure 2 when the door is open, do not re-adjust the chain.

NOTE: During future maintenance, ALWAYS pull the emergency release handle to disconnect trolley before adjusting chain. You may notice loosening of chain after Adjustment Step 3 (Test the Safety Reversal System). Check for proper tension and readjust chain if necessary. Then repeat Adjustment Step 3.

You have now finished assembling your garage door opener. Please read the following warnings before proceeding to the installation section.

Figure 1

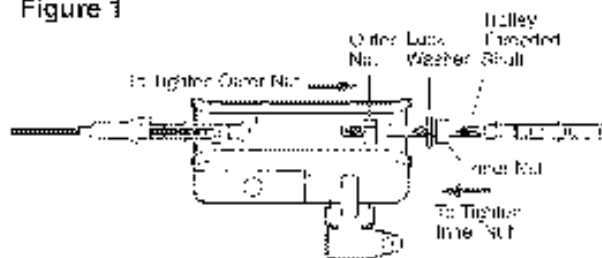
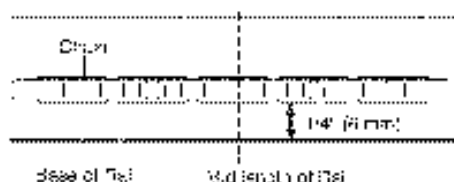

Figure 2



INSTALLATION

IMPORTANT INSTALLATION INSTRUCTIONS

⚠️ WARNING

To reduce the risk of SEVERE INJURY or DEATH:

1. READ AND FOLLOW ALL INSTALLATION WARNINGS AND INSTRUCTIONS.
2. Install garage door opener only on properly balanced and lubricated garage door. An improperly balanced door may not reverse when required and could result in SEVERE INJURY or DEATH.
3. ALL repairs to cables, spring assemblies and other hardware MUST be made by a trained door systems technician BEFORE installing opener.
4. Disable ALL locks and remove ALL ropes connected to garage door BEFORE installing opener to avoid entanglement.
5. Install garage door opener 7 feet (2.13 m) or more above floor.
6. Manual emergency release handle 6 feet (1.83 m) above floor.
7. NEVER connect garage door opener to power source until instructed to do so.
8. NEVER wear catches, rings or loose clothing while installing or servicing opener. They could be caught in garage door or opener mechanisms.
9. Install wall-mounted garage door control:
 - within sight of the garage door.
 - out of reach of children at minimum height of 5 feet (1.5 m).
 - away from ALL moving parts of the door.
10. Place entrapment warning label on wall next to garage door control.
11. Place manual release/safety reverse test label in plain view on inside of garage door.
12. Upon completion of installation, test safety reversal system. Door MUST reverse on contact with a 1-1/2" (3.8 cm) high object (or a 2x4 laid flat) on the floor.

INSTALLATION STEP 1

Determine the Header Bracket Location

WARNING

To prevent possible **SERIOUS INJURY** or **DEATH**:

- Header bracket **MUST** be **RIGIDLY** fastened to structural support on header wall or ceiling, otherwise garage door might not reverse when required. **DO NOT** install header bracket over drywall.
- Concrete anchors **MUST** be used if mounting header bracket or 2x4 into masonry.
- **NEVER** try to loosen, move or adjust garage door, springs, cables, pulleys, brackets, or their hardware, all of which are under **EXTREME** tension.
- **ALWAYS** call a trained door systems technician if garage door binds, sags, or is out of balance. An unbalanced garage door might not reverse when required.

Installation procedures vary according to garage door types. Follow the instructions which apply to your door.

1. Close the door and mark the inside vertical centerline of the garage door.
2. Extend the line onto the header wall above the door.

You can fasten the header bracket within 4 feet (1.22 m) of the left or right of the door center only if a torsion spring or center bearing plate is in the way; or you can attach it to the ceiling (see page 13) when clearance is minimal. (It may be mounted on the wall upside down if necessary, to gain approximately 1/2" (1 cm).

If you need to install the header bracket on a 2x4 (on wall or ceiling), use lag screws (not provided) to securely fasten the 2x4 to structural supports as shown here and on page 13.

3. Open your door to the highest point of travel as shown. Draw an intersecting horizontal line on the header wall above the high point:

- 2' (5 cm) above the high point for sectional door and one-piece door with track.
- 8" (20 cm) above the high point for one-piece door without track.

This height will provide travel clearance for the top edge of the door.

NOTE: If the total number of inches exceeds the height available in your garage, use the maximum height possible, or refer to page 13 for ceiling installation.

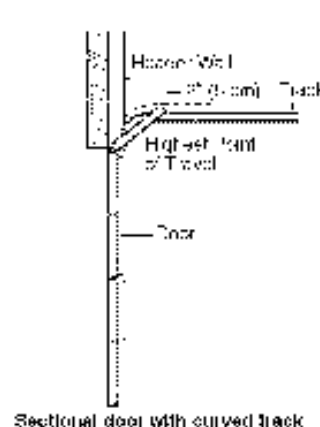
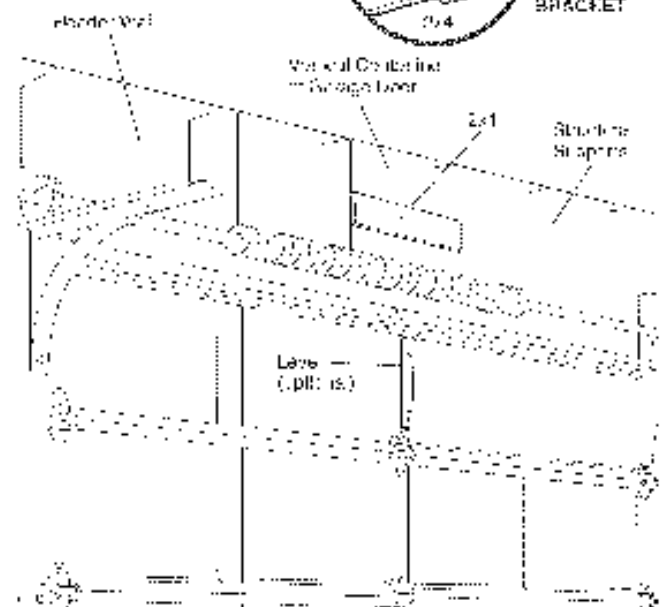

Sectional door with curved track

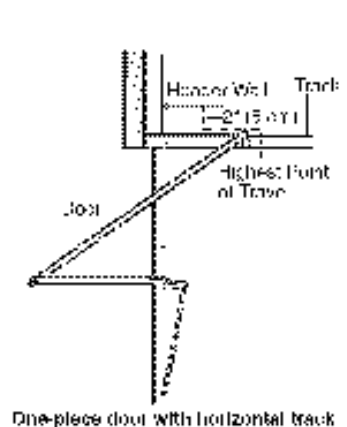

One-piece door with horizontal track

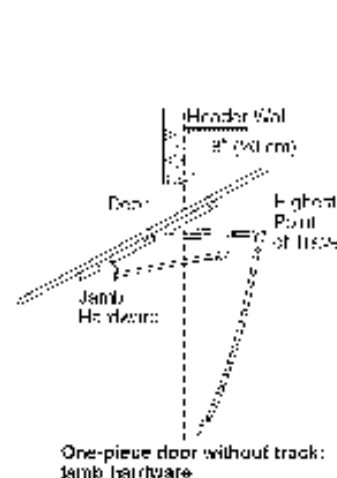

One-piece door without track: jamb hardware

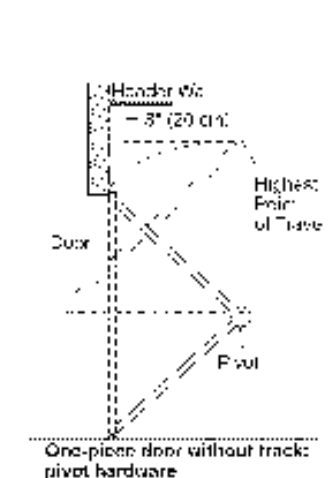

One-piece door without track: pivot hardware

INSTALLATION STEP 2

Install the Header Bracket

You can attach the header bracket either to the wall above the garage door, or to the ceiling. Follow the instructions which will work best for your particular requirements. **Do not install the header bracket over drywall. If installing into masonry, use concrete anchors (not provided).**

WALL HEADER BRACKET INSTALLATION

- Center the bracket on the vertical centerline with the bottom edge of the bracket on the horizontal line as shown (with the arrow pointing toward the ceiling).
- Mark the vertical set of bracket holes (do not use the holes designated for ceiling mount). Drill $3/16"$ pilot holes and fasten the bracket securely to a structural support with the hardware provided.

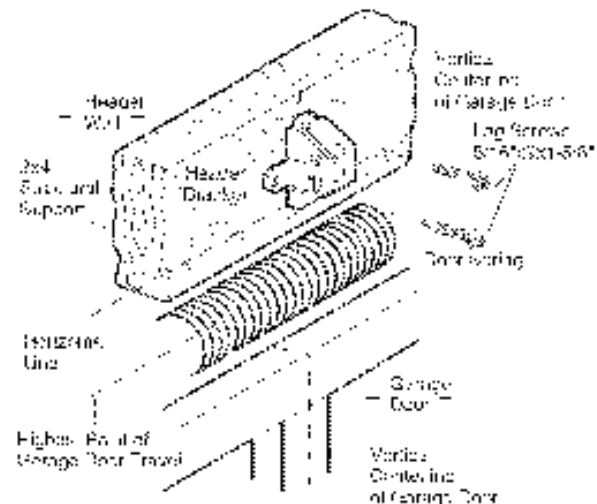
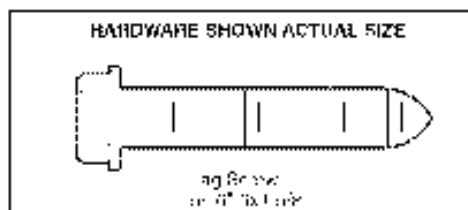

CEILING HEADER BRACKET INSTALLATION

- Extend the vertical centerline onto the ceiling as shown.
- Center the bracket on the vertical mark, no more than 6' (15 cm) from the wall. Make sure the arrow is pointing away from the wall. The bracket can be mounted flush against the ceiling when clearance is minimal.
- Mark the side holes. Drill $3/16"$ pilot holes and fasten bracket securely to a structural support with the hardware provided.

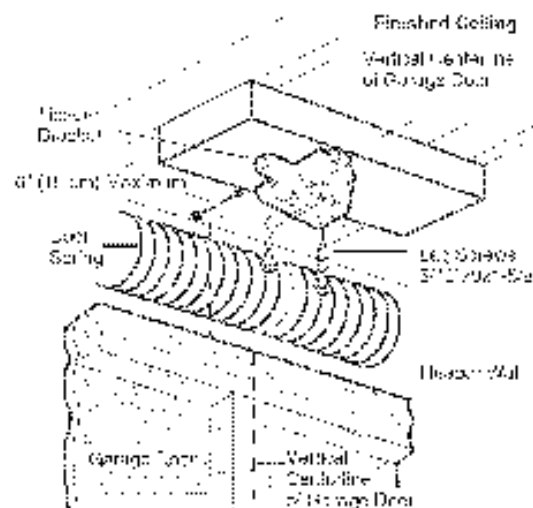
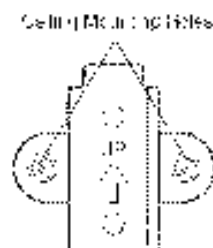

INSTALLATION STEP 3

Attach the Rail to the Header Bracket

NOTE: (Optional) With some existing installations, you may re-use the old header bracket with the two plastic spacers included in the hardware bag. Place the spacers inside the bracket on each side of the rail, as illustrated.

- Position the opener on the garage floor below the header bracket. Use packing material as a protective base. **NOTE:** If the door spring is in the way you'll need help. Have someone hold the opener securely on a temporary support to allow the rail to clear the spring.
- Position the rail bracket against the header bracket.
- Align the bracket holes and join with a clevis pin $5/16"$ x $1-1/2"$ as shown.
- Insert a ring fastener to secure.

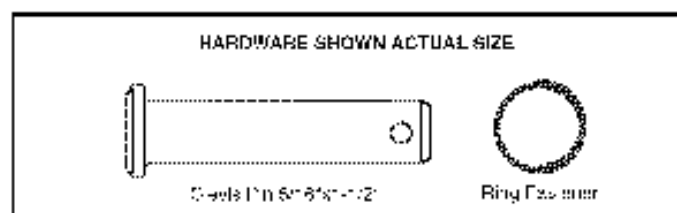
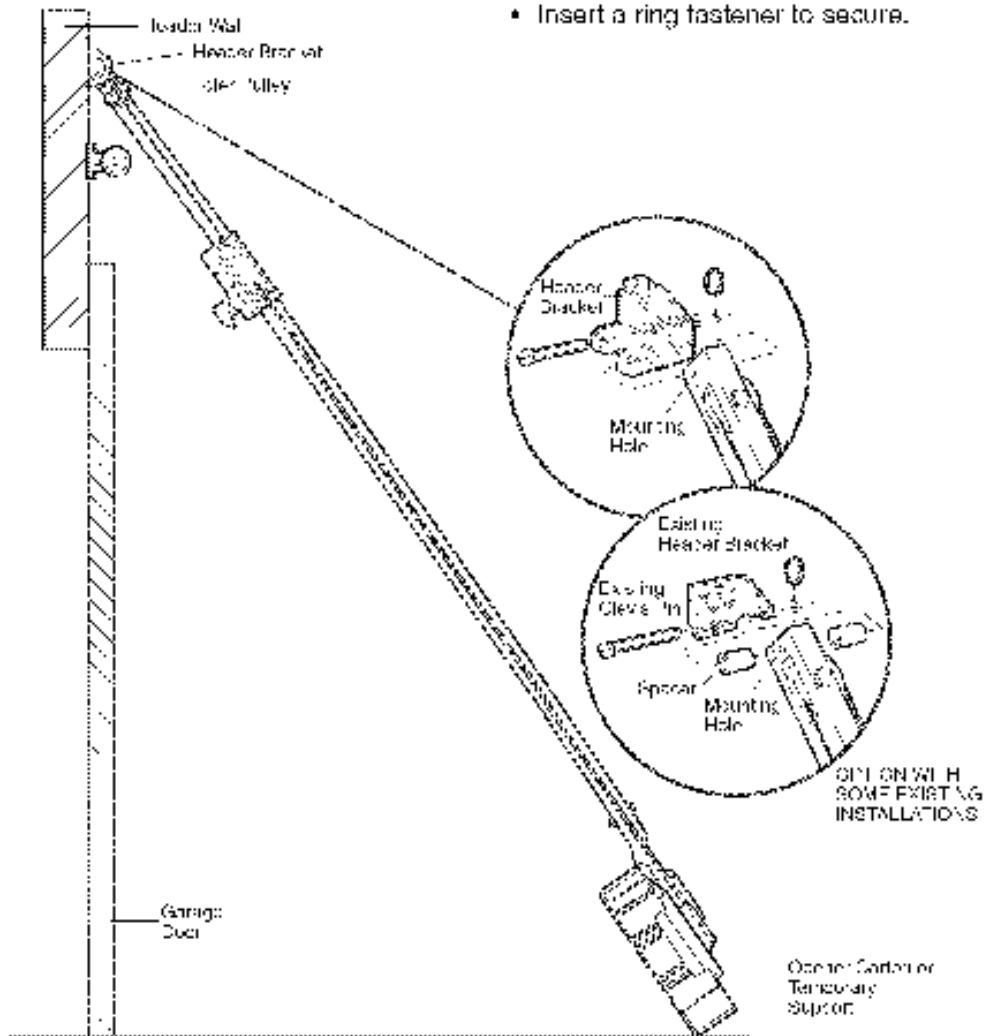

INSTALLATION STEP 4

Position the Opener

Follow instructions which apply to your door type as illustrated.

SECTIONAL DOOR OR ONE-PIECE DOOR WITH TRACK

A 2x4 laid flat is convenient for setting an ideal door-to-rail distance.

- Remove foam packaging.
- Raise the opener onto a stepladder. You will need help at this point if the ladder is not tall enough.
- Open the door all the way and place a 2x4 laid flat on the top section beneath the rail.
- If the top section or panel hits the trolley when you raise the door, pull down on the trolley release arm to disconnect inner and outer sections. Slide the outer trolley toward the motor unit. The trolley can remain disconnected until Installation Step 12 is completed.

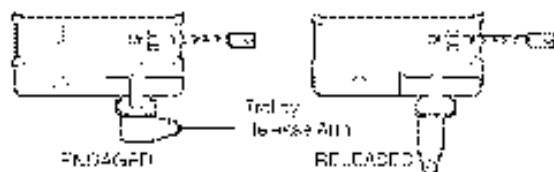

ONE-PIECE DOOR WITHOUT TRACK

A 2x4 on its side is convenient for setting an ideal door-to-rail distance.

- Remove foam packaging.
- Raise the opener onto a stepladder. You will need help at this point if the ladder is not tall enough.
- Open the door all the way and place a 2x4 on its side on the top section of the door beneath the rail.
- The top of the door should be level with the top of the motor unit. Do not position the opener more than 4' (10 cm) above this point.

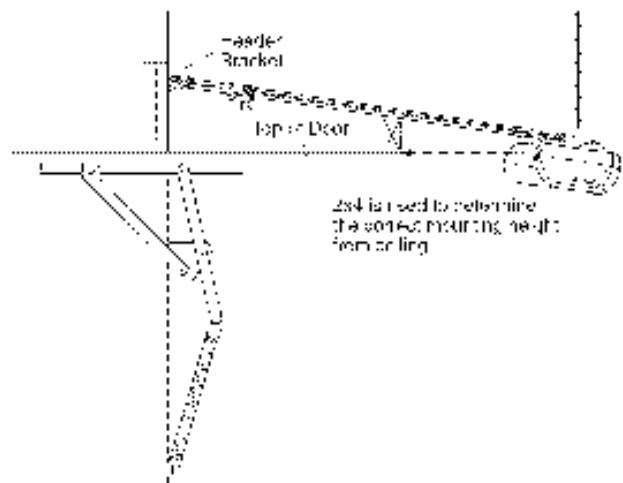

CAUTION

To prevent damage to garage door, rest garage door opener rail on 2x4 placed on top section of door.

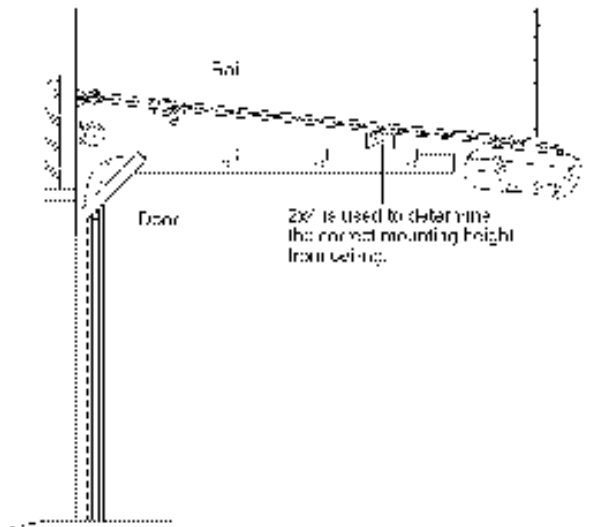

INSTALLATION STEP 5

Hang the Opener

Three representative installations are shown. Yours may be different. Hanging brackets should be angled (Figure 1) to provide rigid support. On finished ceilings (Figure 2 and Figure 3), attach a sturdy metal bracket to structural supports before installing the opener. This bracket and fastening hardware are not provided.

1. Measure the distance from each side of the motor unit to the structural support.
2. Cut both pieces of the hanging bracket to required lengths.
3. Drill $\frac{3}{16}$ " pilot holes in the structural supports.
4. Attach one end of each bracket to a support with $\frac{5}{16}$ "-18x1-7/8" lag screws.
5. Fasten the opener to the hanging brackets with $\frac{5}{16}$ "-18x7/8" hex bolts, lock washers and nuts.
6. Check to make sure the rail is centered over the door (or in line with the header bracket if the bracket is not centered above the door).
7. Remove the 2x4. Operate the door manually. If the door hits the rail, raise the header bracket.

NOTE: DO NOT connect power to opener at this time.

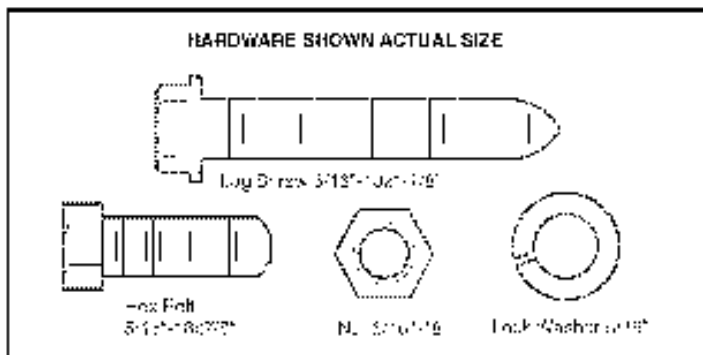

WARNING

To avoid possible SERIOUS INJURY from a falling garage door opener, fasten it SECURELY in structural supports of the garage. Concrete anchors MUST be used if installing any brackets into masonry.

Figure 1

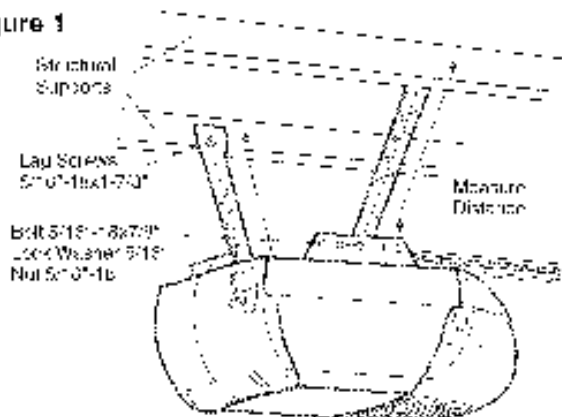

Figure 2

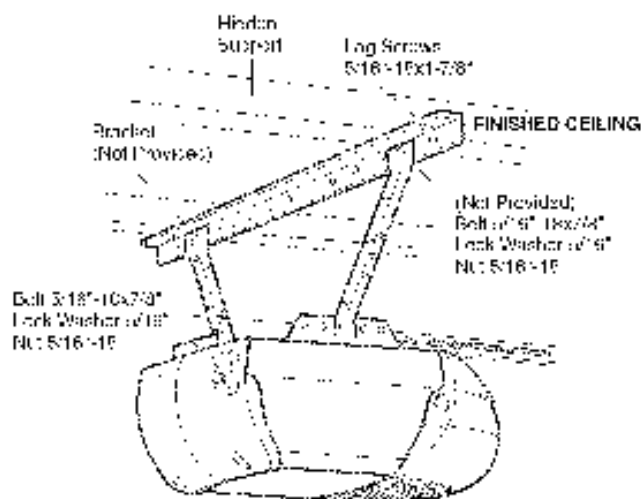
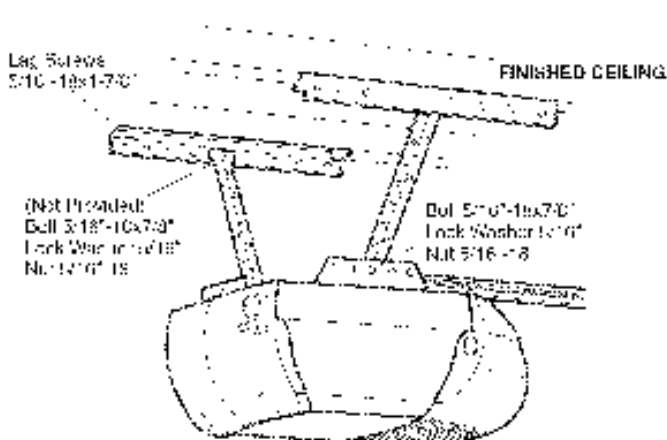

Figure 3



INSTALLATION STEP 6

Install the Door Control

Locate door control within sight of door, at a minimum height of 5 feet (1.5 m) where small children cannot reach, away from moving parts of door and door hardware. If installing into drywall, drill 5/32" holes and use the anchors provided. For pre-wired installations (as in new home construction), it may be mounted to a single gang box (Figure 2).

1. Strip 7/16" (11 mm) of insulation from one end of bell wire and connect to the two screw terminals on back of door control by color: white wire to 2 and white/red wire to the 1.
2. Remove cover by gently prying along one side with a screwdriver (Figure 1). Fasten with 6ABx1-1/4" self-tapping screws (drywall installation) or 6-32x1" machine screws (into gang box) as follows:
 - Install bottom screw, allowing 1/8" (3 mm) to protrude above wall surface.
 - Position bottom of door control on screw head and slide down to secure. Adjust screw for snug fit.
 - Drill and install top screw with care to avoid cracking plastic housing. **Do not overtighten.**
 - Insert top tabs and snap on cover.
3. **(For standard installation only)** Run bell wire up wall and across ceiling to motor unit. Use insulated staples to secure wire in several places. Do not pierce wire with a staple, creating a short or open circuit.

4. Strip 7/16" (11 mm) of insulation from end of bell wire. Connect bell wire to the quick-connect terminals as follows: white to white and white/red to red.

NOTE: When connecting multiple door controls to the opener, twist same color wires together. Insert wires into quick-connect holes: white to white and red/white to red.

5. Position the antenna wire as shown.
6. Use tacks or staples to permanently attach entrapment warning label to wall near door control, and manual release/safety reverse test label in a prominent location on inside of garage door.

NOTE: DO NOT connect power and operate opener at this time. The trolley will travel to the full open position but will not return to the close position until the sensor beam is connected and properly aligned.

⚠️ WARNING

To prevent possible SERIOUS INJURY or DEATH from electrocution:

- Be sure power is not connected BEFORE installing door control.
- Connect ONLY to 24 VOLT low voltage wires.

To prevent possible SERIOUS INJURY or DEATH from a closing garage door:

- Install door control within sight of garage door, out of reach of children, at a minimum height of 5 feet (1.5 m), and away from all moving parts of door.
- NEVER permit children to operate or play with door control push buttons or remote control transmitters.
- Activate door ONLY when it can be seen clearly, is properly adjusted, and there are no obstructions in door travel.
- ALWAYS keep garage door in sight until completely closed. NEVER permit anyone to cross path of closing garage door.

Outside Keylock Accessory Connections

To opener quick-connect terminals: white to white; white/red to red.

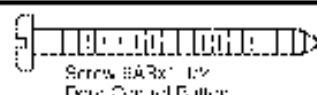

HARDWARE SHOWN
ACTUAL SIZE

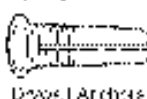
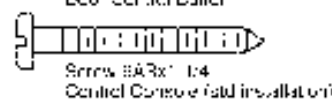
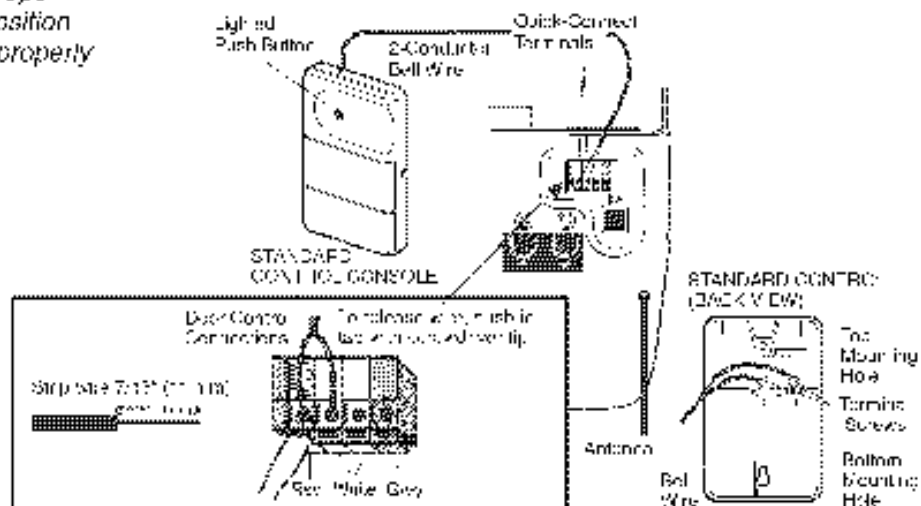

Figure 1



Figure 2

PRE-WIRED INSTALLATION



INSTALLATION STEP 7

Install the Light

- Press the release tabs on both sides of lens. Gently rotate lens back and downward until the lens hinge is in the fully open position. Do not remove the lens.
- Install up to a 100 watt maximum light bulb in the socket. The light will turn ON and remain lit for approximately 4-1/2 minutes when power is connected. Then the light will turn OFF.
- Reverse the procedure to close the lens.
- Use A19, standard neck garage door opener bulbs for replacement.

NOTE: Use only a standard light bulb. The use of short neck or specialty light bulb may overheat the endpanel or light socket.

CAUTION

To prevent possible OVERHEATING of the endpanel or light socket:

- DO NOT use short neck or specialty light bulbs.
- DO NOT use halogen bulbs. Use ONLY incandescent.

To prevent damage to the opener:

- DO NOT use bulbs larger than 100W.
- ONLY use A19 size bulbs.

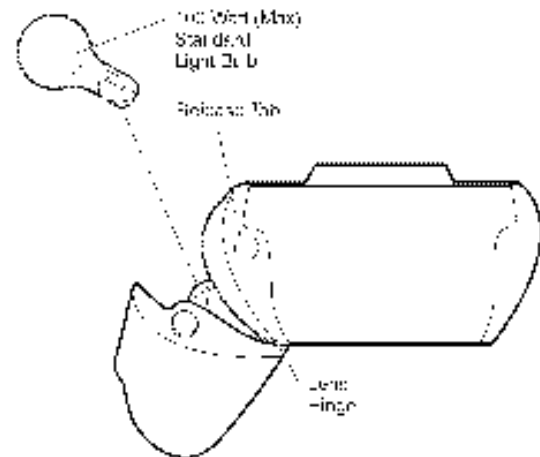

INSTALLATION STEP 8

Attach the Emergency Release Rope and Handle

- Thread one end of the rope through the hole in the top of the red handle so "NOTICE" reads right side up as shown. Secure with an overhand knot at least 1" (2.5 cm) from the end of the rope to prevent slipping.
- Thread the other end of the rope through the hole in the release arm of the outer trolley.
- Adjust rope length so the handle is 6 feet (1.83 m) above the floor. Ensure that the rope and handle clear the tops of all vehicles to avoid entanglement. Secure with an overhand knot.

NOTE: If it is necessary to cut the rope, heat seal the cut end with a match or lighter to prevent unraveling.

WARNING

To prevent possible SERIOUS INJURY or DEATH from a falling garage door:

- If possible, use emergency release handle to disengage trolley ONLY when garage door is CLOSED. Weak or broken springs or unbalanced door could result in an open door falling rapidly and/or unexpectedly.
- NEVER use emergency release handle unless garage doorway is clear of persons and obstructions.
- NEVER use handle to pull door open or closed. If rope knot becomes untied, you could fall.

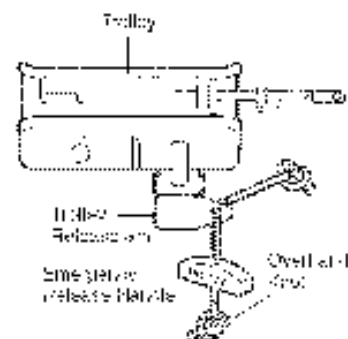

INSTALLATION STEP 9

Electrical Requirements

To avoid installation difficulties, do not run the opener at this time.

To reduce the risk of electric shock, your garage door opener has a grounding type plug with a third grounding pin. This plug will only fit into a grounding type outlet. If the plug doesn't fit into the outlet you have, contact a qualified electrician to install the proper outlet.

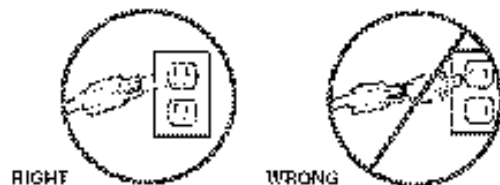

If permanent wiring is required by your local code, refer to the following procedure.

To make a permanent connection through the 7/8" hole in the top of the motor unit:

- Remove the motor unit cover screws and set the cover aside.
- Remove the attached 3-prong cord.
- Connect the black (line) wire to the screw on the brass terminal; the white (neutral) wire to the screw on the silver terminal; and the ground wire to the green ground screw. **The opener must be grounded.**
- Reinstall the cover.

To avoid installation difficulties, do not run the opener at this time.

WARNING

To prevent possible SERIOUS INJURY or DEATH from electrocution or fire:

- Be sure power is not connected to the opener, and disconnect power to circuit BEFORE removing cover to establish permanent wiring connection.
- Garage door installation and wiring MUST be in compliance with all local electrical and building codes.
- NEVER use an extension cord, 2-wire adapter, or change plug in any way to make it fit outlet. Be sure the opener is grounded.

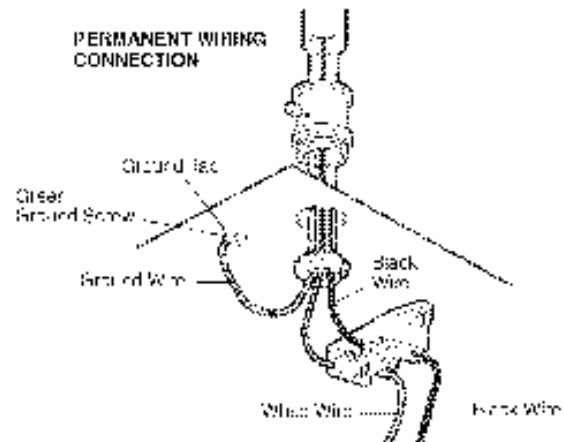

INSTALLING THE BRACKETS

Be sure power to the opener is disconnected. Install and align the brackets so the sensors will face each other across the garage door, with the beam no higher than 6" (15 cm) above the floor. They may be installed in one of three ways, as follows.

Garage door track installation (preferred):

- Slip the curved arms over the rounded edge of each door track, with the curved arms facing the door. Snap into place against the side of the track. It should lie flush, with the lip hugging the back edge of the track, as shown in Figure 1.

If your door track will not support the bracket securely, wall installation is recommended.

Wall installation (Figure 2 & 3):

- Place the bracket against the wall with curved arms facing the door. Be sure there is enough clearance for the sensor beam to be unobstructed.
- If additional depth is needed, an extension bracket (See Accessories) or wood blocks can be used.
- Use bracket mounting holes as a template to locate and drill (2) 3/16" diameter pilot holes on the wall at each side of the door, no higher than 6" (15 cm) above the floor.
- Attach brackets to wall with lag screws (Not provided).
- If using extension brackets or wood blocks, adjust right and left assemblies to the same distance out from the mounting surface. Make sure all door hardware obstructions are cleared.

Floor installation (Figure 4):

- Use wood blocks or extension brackets (See Accessories) to elevate sensor brackets so the lenses will be no higher than 6" (15 cm) above the floor.
- Carefully measure and place right and left assemblies at the same distance out from the wall. Be sure all door hardware obstructions are cleared.
- Fasten to the floor with concrete anchors as shown.

Figure 1 DOOR TRACK MOUNT (RIGHT SIDE)

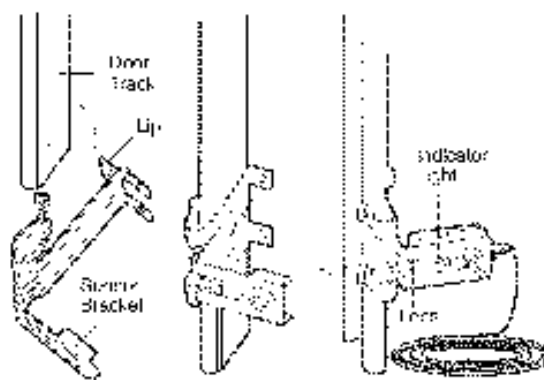

Figure 2

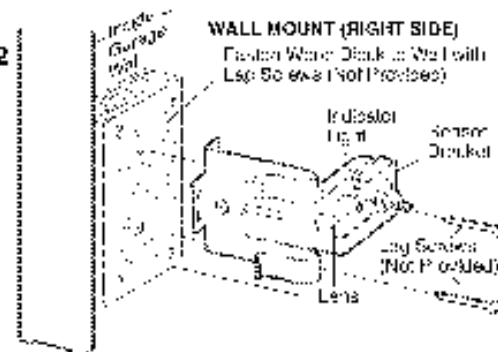

Figure 3

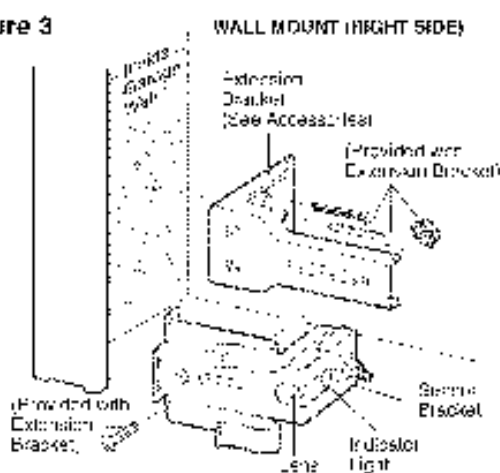
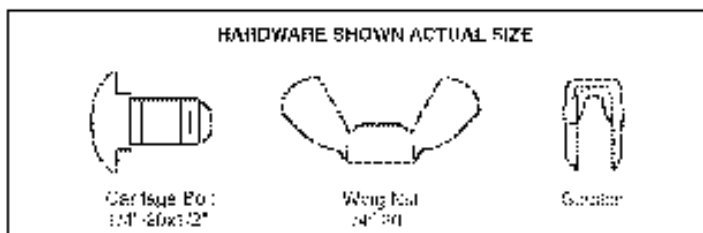
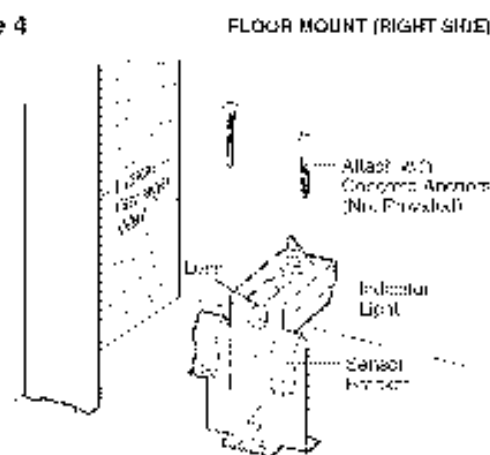

Figure 4



MOUNTING AND WIRING THE SAFETY REVERSING SENSORS

- Slide a 1/4"-20x1/2" carriage bolt head into the slot on each sensor. Use wing nuts to fasten sensors to brackets, with lenses pointing toward each other across the door. Be sure the lens is not obstructed by a bracket extension (Figure 5).
- Finger tighten the wing nuts.
- Run the wires from both sensors to the opener. Use insulated staples to secure wire to wall and ceiling.
- Strip 7/16" (11 mm) of insulation from each set of wires. Separate white and white/black wires sufficiently to connect to the opener quick-connect terminals. Twist like colored wires together. Insert wires into quick-connect holes: white to white and white/black to grey (Figure 6).

ALIGNING THE SAFETY REVERSING SENSORS

- Plug in the opener. The indicator lights in both the *sending* and *receiving eyes* will *glow steadily* if wiring connections and alignment are correct.

The *sending eye* amber indicator light will glow regardless of alignment or obstruction. If the green indicator light in the *receiving eye* is off, dim, or flickering (and the invisible light beam path is not obstructed), alignment is required.

- Loosen the *sending eye* wing nut and readjust, aiming directly at the *receiving eye*. Lock in place.
- Loosen the *receiving eye* wing nut and adjust sensor until it receives the sender's beam. When the green indicator light *glows steadily*, tighten the wing nut.

Figure 5



TROUBLESHOOTING THE SAFETY REVERSING SENSORS

1. If the *sending eye* indicator light does not *glow steadily* after installation, check for:
 - Electric power to the opener.
 - A short in the white or white/black wires. These can occur at staples, or at opener connections.
 - Incorrect wiring between sensors and opener.
 - A broken wire.
2. If the *sending eye* indicator light *glows steadily* but the *receiving eye* indicator light doesn't:
 - Check alignment.
 - Check for an open wire to the *receiving eye*.
3. If the *receiving eye* indicator light is dim, realign either sensor.

NOTE: When the invisible beam path is obstructed or misaligned while the door is closing, the door will reverse. If the door is already open, it will not close. The opener lights will blink 10 times. See page 20.

Figure 6

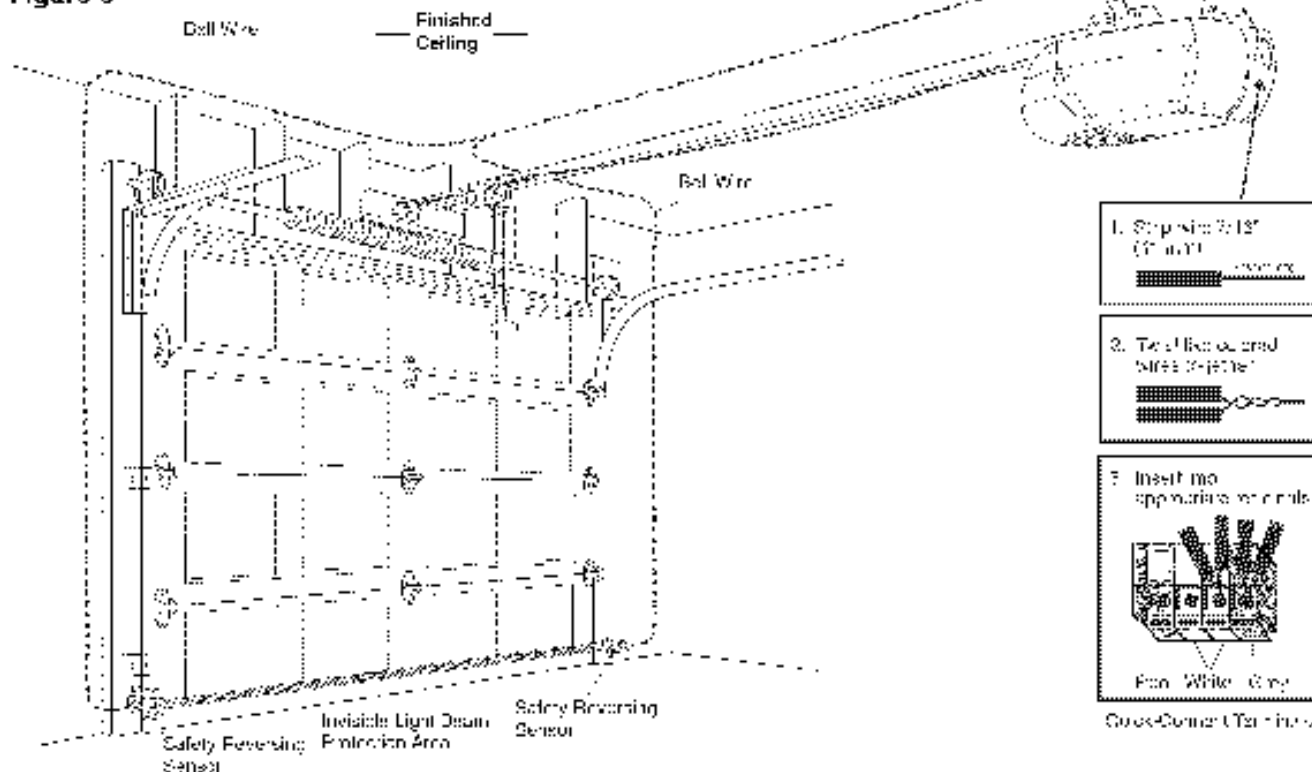

INSTALLATION STEP 11

Fasten the Door Bracket

Follow instructions which apply to your door type as illustrated below or on the following page.

A horizontal reinforcement brace should be long enough to be secured to two vertical supports. A vertical reinforcement brace should cover the height of the top panel.

The illustration shows one piece of angle iron as the horizontal brace. For the vertical brace, two pieces of angle iron are used to create a U-shaped support (Figure 1). The best solution is to check with your garage door manufacturer for an opener installation door reinforcement kit.

NOTE: Many vertical brace installations provide for direct attachment of the clevis pin and door arm. In this case you will not need the door bracket; proceed to Installation Step 12.

SECTIONAL DOORS

- Center the door bracket on the previously marked vertical centerline used for the header bracket installation. Note correct UP placement, as stamped inside the bracket (Figure 2).
- Position the bracket on the face of the door within the following limits:
 - The top edge of the bracket 2"-4" (5-10 cm) below the top edge of the door.
 - The top edge of the bracket directly below any structural support across the top of the door.

CAUTION

Fiberglass, aluminum or lightweight steel garage doors **WILL REQUIRE** reinforcement BEFORE installation of door bracket. Contact your door manufacturer for reinforcement kit.

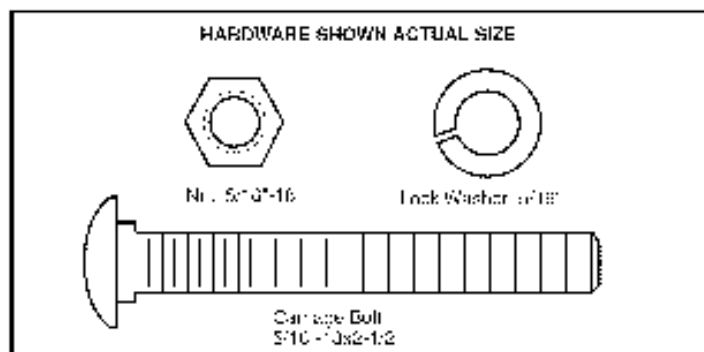

- Mark and drill 5/16" left and right fastening holes. Secure the bracket as shown in Figure 1 if there is vertical reinforcement.

If your installation doesn't require vertical reinforcement but does need top and bottom fastening holes for the door bracket, fasten as shown in Figure 2.

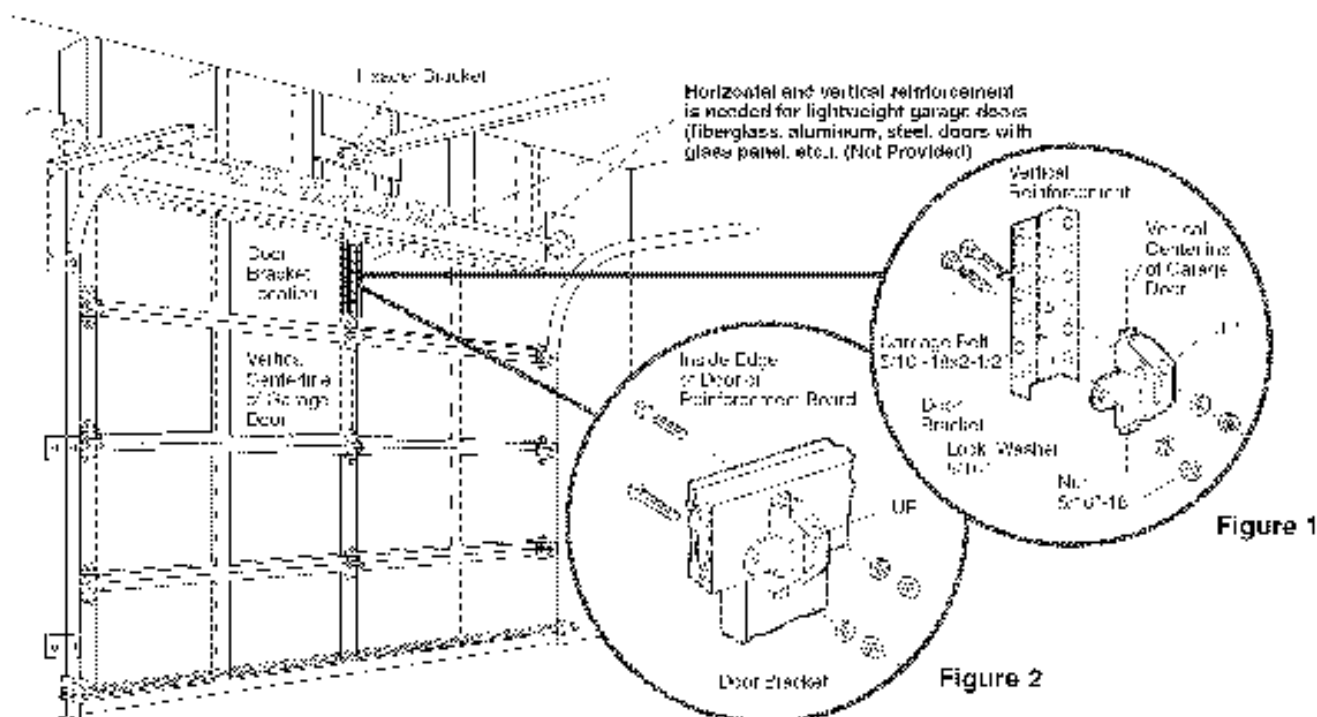

ONE-PIECE DOORS

Please read and comply with the warnings and reinforcement instructions on the previous page. They apply to one-piece doors also.

- Center the door bracket on the top of the door, in line with the header bracket as shown. Mark either the left and right, or the top and bottom holes.
- Drill 5/16" pilot holes and fasten the bracket with hardware supplied.

If the door has no exposed framing, drill 3/16" pilot holes and fasten the bracket with 3/16"x1-1/2" lag screws (not provided) to the top of the door.

NOTE: The door bracket may be installed on the top edge of the door if required for your installation. (Refer to the dotted line optional placement drawing.) Drill 3/16" pilot holes and substitute 5/16"x1-1/2" lag screws (not provided) to fasten the bracket to the door.

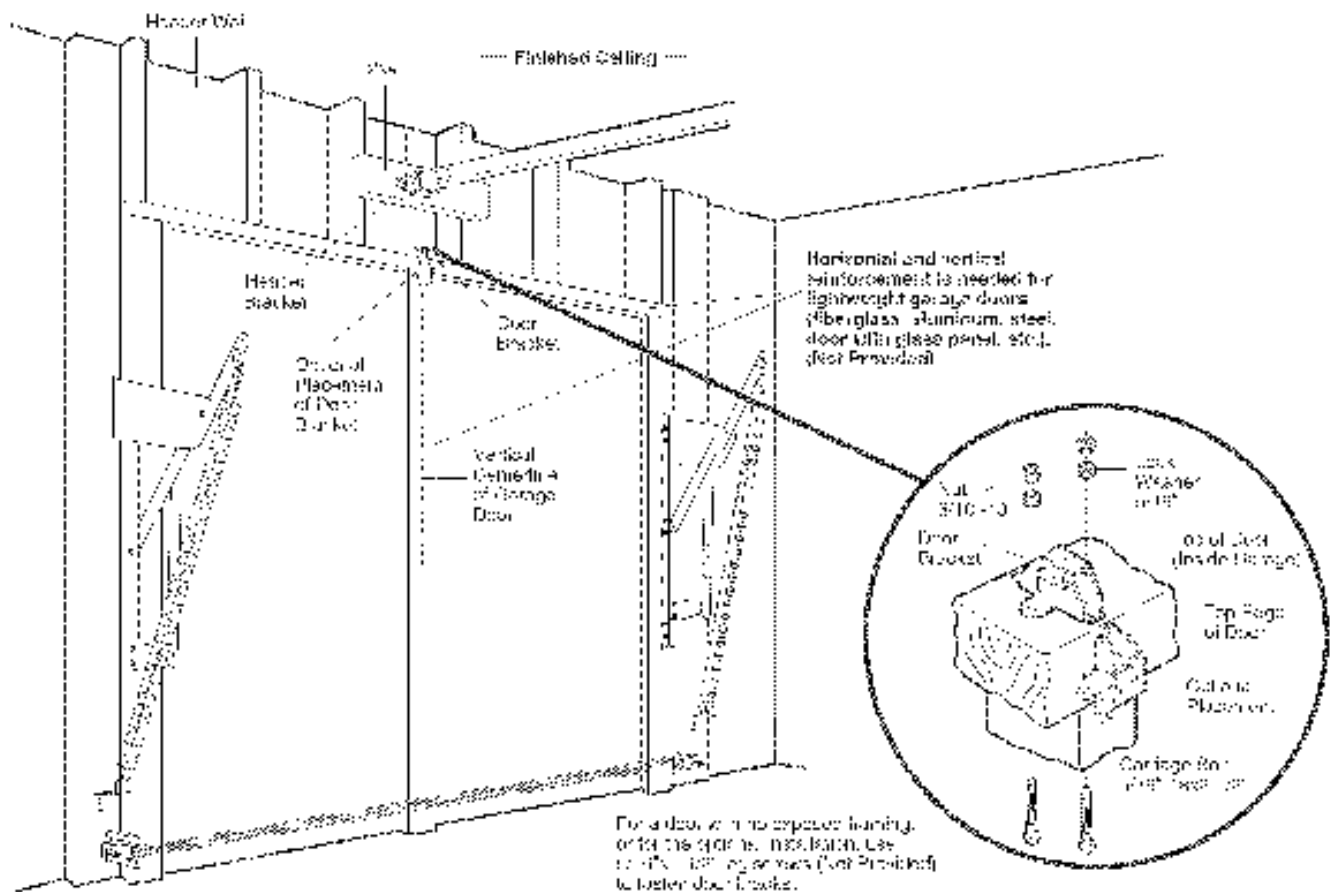
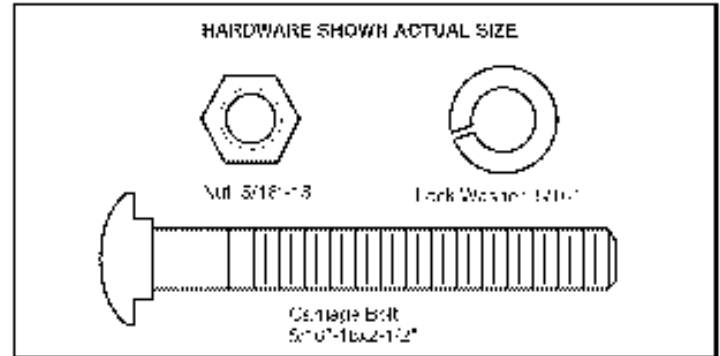

INSTALLATION STEP 12

Connect Door Arm to Trolley

Follow instructions which apply to your door type as illustrated below and on the following page.

SECTIONAL DOORS ONLY

- Make sure garage door is fully closed. Pull the emergency release handle to disconnect the outer trolley from the inner trolley. Slide the outer trolley back (away from the pulley) about 8" (20 cm) as shown in Figures 1, 2 and 3.

• Figure 1:

- Fasten straight door arm section to outer trolley with the 5/16"x1" clevis pin. Secure the connection with a ring fastener.
- Fasten curved section to the door bracket in the same way, using the 5/16"x1-1/4" clevis pin.

• Figure 2:

- Bring arm sections together. Find two pairs of holes that line up and join sections. Select holes as far apart as possible to increase door arm rigidity.

• Figure 3, Hole alignment alternative:

If holes in curved arm are above holes in straight arm, disconnect straight arm. Cut about 6" (15 cm) from the solid end. Reconnect to trolley with cut end down as shown.

- Bring arm sections together.
- Find two pairs of holes that line up and join with bolts, lock washers and nuts.
- Pull the emergency release handle toward the opener at a 45° angle so that the trolley release arm is horizontal. Proceed to Adjustment Step 1, page 27. Trolley will re-engage automatically when opener is operated.

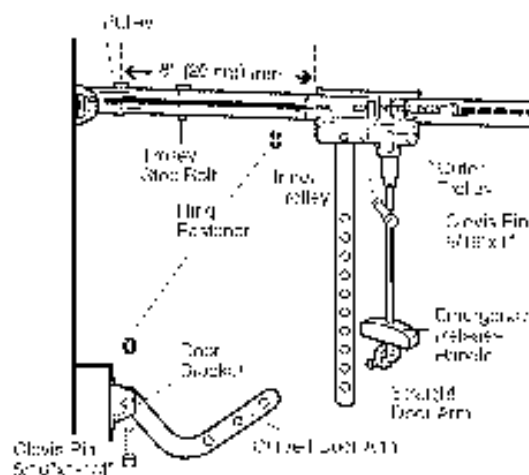

Figure 1

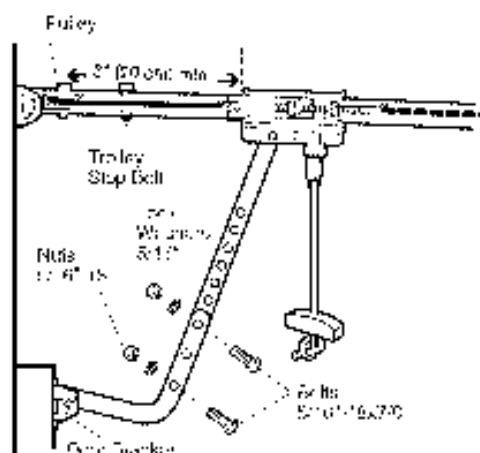

Figure 2

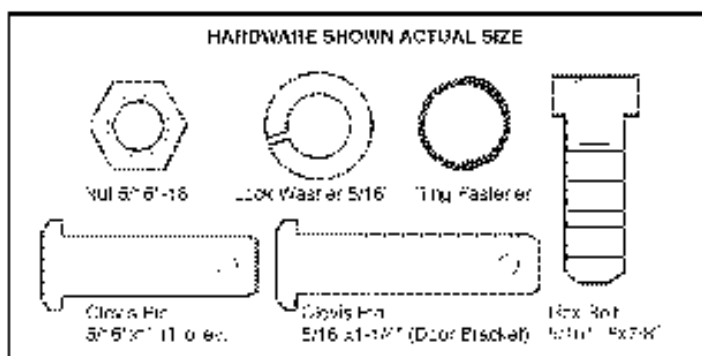

Figure 3

HARDWARE SHOWN ACTUAL SIZE



Nut 5/16" - 16



Lock Washer 5/16"



Ring Fastener

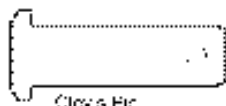

Clevis Pin 5/16" x 1" (10 ec.)

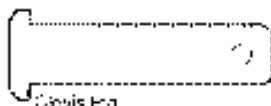

Clevis Pin 5/16" x 1-1/4" (Door Bracket)

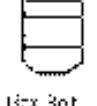

Hex Bolt 1/2" x 7/8"

ALL ONE-PIECE DOORS

1. Assemble the door arm, Figure 4:

- Fasten the straight and curved door arm sections together to the longest possible length (with a 2 or 3 hole overlap).
- With the door closed, connect the straight door arm section to the door bracket with the 5/16" x 1-1/4" clevis pin.
- Secure with a ring fastener.

2. Adjustment procedures, Figure 5:

- On one-piece doors, before connecting the door arm to the trolley, the travel limits must be adjusted. Limit adjustment screws are located on the left side panel as shown on page 27. Follow adjustment procedures below.
- **Open door adjustment: decrease UP travel limit**
 - Turn the UP limit adjustment screw counter-clockwise 4 turns.
 - Press the Door Control push button. The trolley will travel to the fully open position.
 - Manually raise the door to the open position (parallel to the floor), and lift the door arm to the trolley. The arm should touch the trolley just in back of the door arm connector hole. Refer to the fully open trolley/door arm positions in the illustration. If the arm does not extend far enough, adjust the limit further. One full turn equals 2" (5 cm) of trolley travel.
- **Closed door adjustment: decrease DOWN travel limit**
 - Turn the DOWN limit adjustment screw clockwise 4 complete turns.

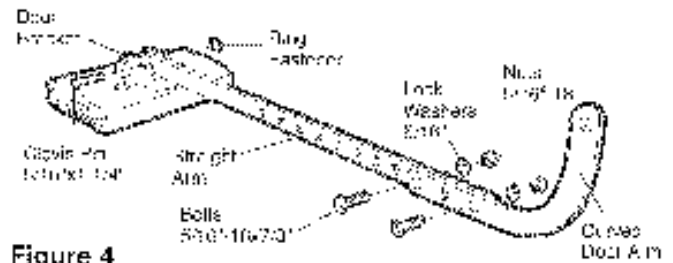

Figure 4

- Press the Door Control push button. The trolley will travel to the fully closed position.
- Manually close the door and lift the door arm to the trolley. The arm should touch the trolley just ahead of the door arm connector hole. Refer to the fully closed trolley/door arm positions in the illustration. If the arm is behind the connector hole, adjust the limit further. One full turn equals 2" (5 cm) of trolley travel.

3. Connect the door arm to the trolley:

- Close the door and join the curved arm to the connector hole in the trolley with the remaining clevis pin. It may be necessary to lift the door slightly to make the connection.
- Secure with a ring fastener.
- Run the opener through a complete travel cycle. If the door has a slight "backward" slant in full open position as shown in the illustration, decrease the UP limit until the door is parallel to the floor.

NOTE: When setting the up limit on the following page, the door should not have a "backward" slant when fully open as illustrated below. A slight backward slant will cause unnecessary bucking and/or jacking operation as the door is being opened or closed from the fully open position.

Figure 5

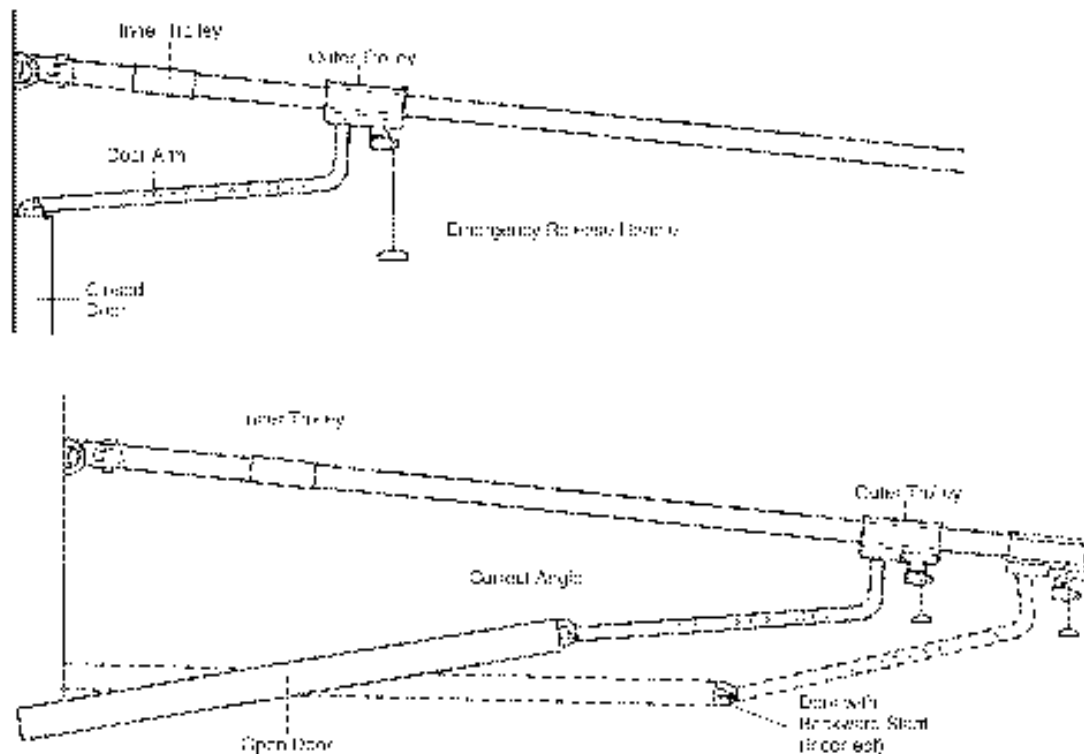

ADJUSTMENT STEP 1

Adjust the UP and DOWN Travel Limits

Limit adjustment settings regulate the points at which the door will stop when moving up or down.

To operate the opener, press the Door Control push bar. Run the opener through a complete travel cycle.

- Does the door open and close completely?
- Does the door stay closed and not reverse unintentionally when fully closed?

If your door passes both of these tests, no limit adjustments are necessary unless the reversing test fails (Adjustment Step 3, page 29).

Adjustment procedures are outlined below. Read the procedures carefully before proceeding to Adjustment Step 2. Use a screwdriver to make limit adjustments. **Run the opener through a complete travel cycle after each adjustment.**

NOTE: Repeated operation of the opener during adjustment procedures may cause the motor to overheat and shut off. Simply wait 15 minutes and try again. If anything interferes with the door's upward travel, it will stop. If anything interferes with the door's downward travel (including binding or unbalanced doors), it will reverse.

HOW AND WHEN TO ADJUST THE LIMITS

- **If the door does not open completely but opens at least five feet (1.5 m):**

Increase up travel. Turn the UP limit adjustment screw clockwise. One turn equals 2" (5 cm) of travel.

NOTE: To prevent the trolley from hitting the cover protection bolt, keep a minimum distance of 2-4" (5 cm - 10 cm) between the trolley and the bolt.

- **If door does not open at least 5 feet (1.5 m):**
Adjust the UP (open) force as explained in Adjustment Step 2.

- **If the door does not close completely:**

Increase down travel. Turn the down limit adjustment screw counterclockwise. One turn equals 2" (5 cm) of travel.

If door still won't close completely and the trolley bumps into the pulley bracket (page 4), try lengthening the door arm (page 25) and decreasing the down limit.

- **If the opener reverses in fully closed position:**

Decrease down travel. Turn the down limit adjustment screw clockwise. One turn equals 2" (5 cm) of travel.

WARNING

Without a properly installed safety reversal system, persons (particularly small children) could be SERIOUSLY INJURED or KILLED by a closing garage door.

- Incorrect adjustment of garage door travel limits will interfere with proper operation of safety reversal system.
- If one control (force or travel limits) is adjusted, the other control may also need adjustment.
- After ANY adjustments are made, the safety reversal system **MUST** be tested. Door **MUST** reverse on contact with 1-1/2" high (3.8 cm) object (or 2x4 laid flat) on floor.

CAUTION

To prevent damage to vehicles, be sure fully open door provides adequate clearance.

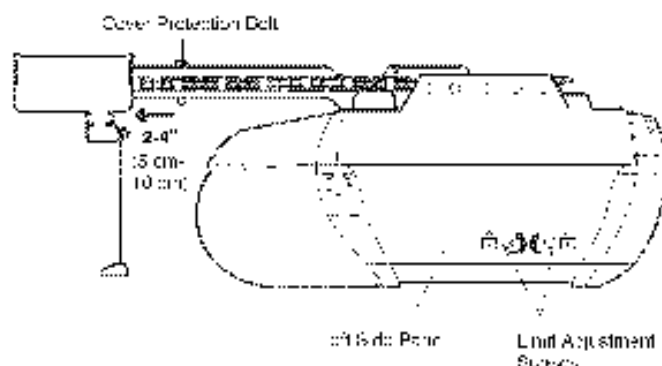

- **If the door reverses when closing and there is no visible interference to travel cycle:**

If the opener lights are flashing, the Safety Reversing Sensors are either not installed, misaligned, or obstructed. See Troubleshooting, page 22.

Test the door for binding: Pull the emergency release handle. Manually open and close the door. If the door is binding or unbalanced, call for a trained door systems technician. If the door is balanced and not binding, adjust the DOWN (close) force. See Adjustment Step 2.

ADJUSTMENT STEP 2

Adjust the Force

Force adjustment controls are located on the back panel of the motor unit. Force adjustment settings regulate the amount of power required to open and close the door.

If the forces are set too light, door travel may be interrupted by nuisance reversals in the down direction and stops in the up direction. Weather conditions can affect the door movement, so occasional adjustment may be needed.

The maximum force adjustment range is about 3/4 of a complete turn. Do not force controls beyond that point. Turn force adjustment controls with a screwdriver.

NOTE: If anything interferes with the door's upward travel, it will stop. If anything interferes with the door's downward travel (including binding or unbalanced doors), it will reverse.

HOW AND WHEN TO ADJUST THE FORCES

1. Test the DOWN (close) force

- Grasp the door bottom when the door is about halfway through DOWN (close) travel. The door should reverse. *Reversal halfway through down travel does not guarantee reversal on a 1-1/2" (3.8 cm) obstruction. See Adjustment Step 3, page 29. If the door is hard to hold or doesn't reverse, DECREASE the DOWN (close) force by turning the control counterclockwise.* Make small adjustments until the door reverses normally. After each adjustment, run the opener through a complete cycle.
- **If the door reverses during the down (close) cycle and the opener lights aren't flashing, INCREASE DOWN (close) force by turning the control clockwise.** Make small adjustments until the door completes a close cycle. After each adjustment, run the opener through a complete travel cycle. *Do not increase the force beyond the minimum amount required to close the door.*

2. Test the UP (open) force

- Grasp the door bottom when the door is about halfway through UP (open) travel. The door should stop. **If the door is hard to hold or doesn't stop, DECREASE UP (open) force by turning the control counterclockwise.** Make small adjustments until the door stops easily and opens fully. After each adjustment, run the opener through a complete travel cycle.
- **If the door doesn't open at least 5 feet (1.5 m), INCREASE UP (open) force by turning the control clockwise.** Make small adjustments until door opens completely. Readjust the UP limit if necessary. After each adjustment, run the opener through a complete travel cycle.

WARNING

Without a properly installed safety reversal system, persons (particularly small children) could be **SEVERELY INJURED** or **KILLED** by a closing garage door.

- Too much force on garage door will interfere with proper operation of safety reversal system.
- **NEVER** increase force beyond minimum amount required to close garage door.
- **NEVER** use force adjustments to compensate for a binding or sticking garage door.
- If one control (force or travel limits) is adjusted, the other control may also need adjustment.
- After **ANY** adjustments are made, the safety reversal system **MUST** be tested. Door **MUST** reverse on contact with 1-1/2" high (3.8 cm) object (or 2x4 laid flat) on floor.

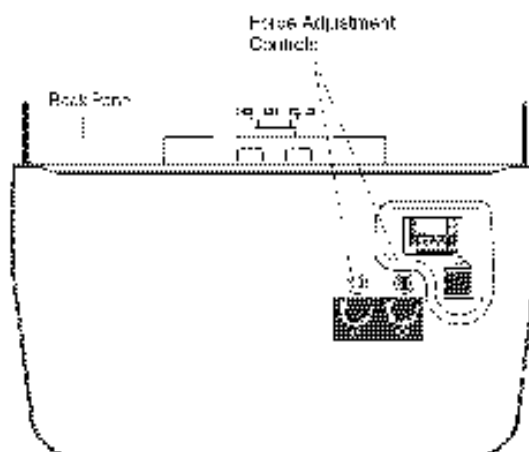

ADJUSTMENT LABEL



ADJUSTMENT STEP 3

Test the Safety Reversal System

TEST

- With the door fully open, place a 1-1/2' (3.8 cm) board (or a 2x4 laid flat) on the floor, centered under the garage door.
- Operate the door in the down direction. The door **must** reverse on striking the obstruction.

ADJUST

- If the door stops on the obstruction, it is not traveling far enough in the down direction. Increase the DOWN limit by turning the DOWN limit adjustment screw counterclockwise 1/4 turn.

NOTE: On a sectional door, make sure limit adjustments do not force the door arm beyond a straight up and down position. See the illustration on page 25.

- Repeat the test.
- When the door reverses on the 1-1/2" (3.8 cm) board, remove the obstruction and run the opener through 3 or 4 complete travel cycles to test adjustment.
- If the unit continues to fail the Safety Reverse Test, call for a trained door systems technician.

IMPORTANT SAFETY CHECK:

Test the Safety Reverse System after:

- Each adjustment of door arm length, limits, or force controls.
- Any repair to or adjustment of the garage door (including springs and hardware).
- Any repair to or buckling of the garage floor.
- Any repair to or adjustment of the opener.

ADJUSTMENT STEP 4

Test The Protector System*

- Press the remote control push button to open the door.
- Place the opener carton in the path of the door.
- Press the remote control push button to close the door. The door will not move more than an inch (2.5 cm), and the opener lights will flash.

The garage door opener will not close from a remote if the indicator light in either sensor is off (alerting you to the fact that the sensor is misaligned or obstructed).

If the opener closes the door when the safety reversing sensor is obstructed (and the sensors are no more than 5" (15 cm) above the floor), call for a trained door systems technician.

WARNING

Without a properly installed safety reversal system, persons (particularly small children) could be **SERIOUSLY INJURED** or **KILLED** by a closing garage door.

- Safety reversal system **MUST** be tested every month.
- If one control (force or travel limit) is adjusted, the other control may also need adjustment.
- After **ANY** adjustments are made, the safety reversal system **MUST** be tested. Door **MUST** reverse on contact with 1-1/2' high (3.8 cm) object (or 2x4 laid flat) on the floor.

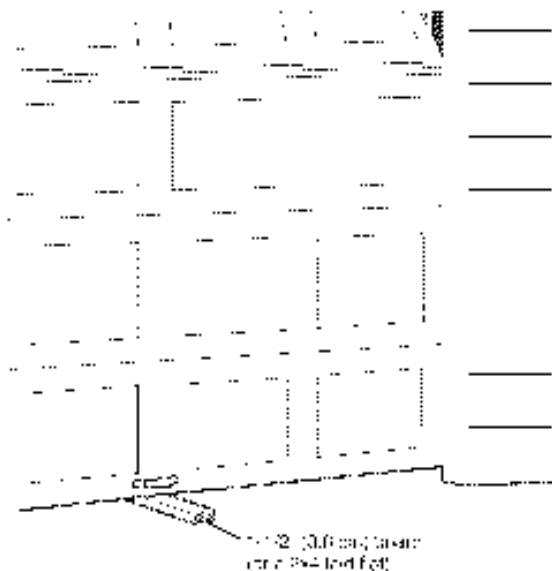

WARNING

Without a properly installed safety reversing sensor, persons (particularly small children) could be **SERIOUSLY INJURED** or **KILLED** by a closing garage door.

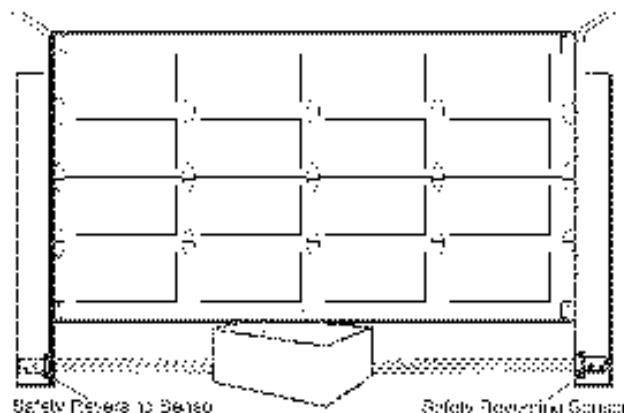

OPERATION

IMPORTANT SAFETY INSTRUCTIONS



To reduce the risk of SEVERE INJURY or DEATH:

1. READ AND FOLLOW ALL WARNINGS AND INSTRUCTIONS.
2. ALWAYS keep remote controls out of reach of children. NEVER permit children to operate or play with garage door control push buttons or remote controls.
3. ONLY activate garage door when it can be seen clearly, it is properly adjusted, and there are no obstructions in door travel.
4. ALWAYS keep garage door in sight until completely closed. NO ONE SHOULD CROSS THE PATH OF THE MOVING DOOR.
5. NO ONE SHOULD GO UNDER A STOPPED, PARTIALLY OPENED DOOR.
6. If possible, use emergency release handle to disengage trolley ONLY when garage door is CLOSED. Weak or broken springs or unbalanced door could result in an open door falling rapidly and/or unexpectedly.
7. NEVER use emergency release handle unless garage doorway is clear of persons and obstructions.
8. NEVER use handle to pull garage door open or closed. If rope knot becomes untied, you could fall.
9. If one control (force or travel limits) is adjusted, the other control may also need adjustment.
10. After ANY adjustments are made, the safety reversal system MUST be tested.
11. Safety reversal system MUST be tested every month. Garage door must reverse on contact with 1-1/2" high (3.8 cm) object (or a 2x4 laid flat) on the floor.
12. ALWAYS KEEP GARAGE DOOR PROPERLY BALANCED (see page 3). An improperly balanced door may not reverse when required and could result in SEVERE INJURY or DEATH.
13. ALL repairs to cables, spring assemblies and other hardware, ALL of which are under EXTREME tension, MUST be made by a trained door systems technician.
14. ALWAYS disconnect electric power to garage door opener BEFORE making any repairs or removing covers.
15. **SAVE THESE INSTRUCTIONS.**

Using Your Garage Door Opener

Your Security+[®] opener and hand-held remote control have been factory-set to a matching code which changes with each use, randomly accessing over 100 billion new codes. Your opener will operate with up to eight Security+[®] remote controls and one Security+[®] Keyless Entry System. If you purchase a new remote, or if you wish to deactivate any remote, follow the instructions in the *Programming* section.

Activate your opener with any of the following:

- *The hand-held Remote Control:* Hold the large push button down until the door starts to move.
- *The wall-mounted Door Control:* Hold the push button or bar down until the door starts to move.
- *The Keyless Entry (See Accessories):* If provided with your garage door opener, it must be programmed before use. See *Programming*.

When the opener is activated (with the safety reversing sensor correctly installed and aligned)

1. If open, the door will close. If closed, it will open.
2. If closing, the door will reverse.
3. If opening, the door will stop.
4. If the door has been stopped in a partially open position, it will close.
5. If obstructed while closing, the door will reverse. If the obstruction interrupts the sensor beam, the opener lights will blink for five seconds.

6. If obstructed while opening, the door will stop.
7. If fully open, the door will not close when the beam is broken. The sensor has no effect in the opening cycle.

If the sensor is not installed, or is misaligned, the door won't close from a hand-held remote. However, you can close the door with the Door Control, the Outdoor Key Switch, or Keyless Entry, *if you activate them until down travel is complete*. If you release them too soon, the door will reverse.

The opener lights will turn on under the following conditions: when the opener is initially plugged in; when power is restored after interruption; when the opener is activated. They will turn off automatically after 4-1/2 minutes. Bulb size is A19. Power is 100 watts maximum. Lights will also turn on when someone walks through the open garage door.

Using the Wall-Mounted Door Control

Press the lighted push button to open or close the door. Press again to reverse the door during the closing cycle or to stop the door while it's opening.

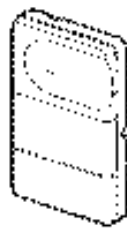

To Open the Door Manually

⚠ WARNING

To prevent possible **SERIOUS INJURY** or **DEATH** from a falling garage door:

- If possible, use emergency release handle to disengage trolley **ONLY** when garage door is **CLOSED**. Weak or broken springs or unbalanced door could result in an open door falling rapidly and/or unexpectedly.
- **NEVER** use emergency release handle unless garage doorway is clear of persons and obstructions.
- **NEVER** use handle to pull door open or closed. If rope knot becomes untied, you could fall.

DISCONNECT THE TROLLEY:

The door should be fully closed if possible. Pull down on the emergency release handle (so that the trolley release arm snaps into a vertical position) and lift the door manually. The *lockout feature* prevents the trolley from reconnecting automatically, and the door can be raised and lowered manually as often as necessary.

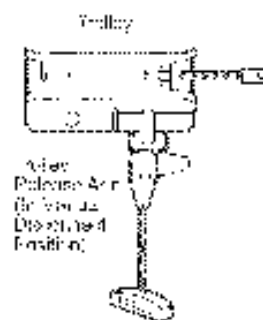

**Lockout position
(Manual disconnect)**

TO RE-CONNECT THE TROLLEY:

Pull the emergency release handle toward the opener at an angle so that the trolley release arm is horizontal. The trolley will reconnect on the next UP or DOWN operation, either manually or by using the door control or remote.

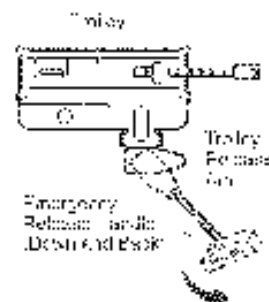

To reconnect

CARE OF YOUR GARAGE DOOR OPENER

LIMIT AND FORCE ADJUSTMENTS:

Weather conditions may cause some minor changes in door operation requiring some re-adjustments, particularly during the first year of operation.

Pages 27 and 28 refer to the limit and force adjustments. Only a screwdriver is required. Follow the instructions carefully.

Repeat the safety reverse test (Adjustment Step 3, page 29) after any adjustment of limits or force.

FORCE CONTROLS



LIMIT CONTROLS



MAINTENANCE SCHEDULE

Once a Month

- Manually operate door. If it is unbalanced or binding, call a trained door systems technician.
- Check to be sure door opens & closes fully. Adjust limits and/or force if necessary. (See pages 27 and 28)
- Repeat the safety reverse test. Make any necessary adjustments. (See Adjustment Step 3)

Twice a Year

- Check chain tension. Disconnect trolley first. Adjust if necessary. (See page 11)

Once a Year

- Oil door rollers, bearings and hinges. The opener does not require additional lubrication. Do not grease the door tracks.

THE REMOTE CONTROL BATTERY

WARNING

- To prevent possible SERIOUS INJURY or DEATH:
- NEVER allow small children near batteries.
 - If battery is swallowed, immediately notify doctor.

The lithium battery should produce power for up to 5 years. To replace battery, use the visor clip or screwdriver blade to pry open the case as shown. Insert battery matching polarity instructions inside the remote cover or on the printed circuit board. Dispose of old battery properly.

Open the case lid, to avoid cracking housing.



ALL OTHER USES OF THIS BATTERY OR THIS OPERATOR, INCLUDING THE USE OF THIS BATTERY OUT OF THE RECEIVER OR TRANSMITTER ARE PROHIBITED. EXCEPT TO BE SHOWN, THE CASE SETTING OF THIS BATTERY IS NOT TO BE OPENED BY ANY OTHER USER SERVICEABLE PARTS.

Total Company is a FCC Licensed FOR HOME USE ONLY OF FCC. Operation is subject to the following conditions: (1) this device may not cause harmful interference, and (2) this device must accept any interference that may be received, including interference that may cause undesired operation.

HAVING A PROBLEM?

1. My door will not close and the light bulbs blink on my motor unit: The safety reversing sensor must be connected and aligned correctly before the garage door opener will move in the down direction.

- Verify the safety sensors are properly installed, aligned and free of any obstructions. Refer to *Installation Step 10: Install The Protector System*.
- Check diagnostic LED for flashes on the motor unit then refer to the *Diagnostic Chart* on the following page.

2. My remotes will not activate the door:

- Reprogram remotes following the programming instructions. Refer to *Programming*.
- If remote will still not activate your door, check diagnostic LED for flashes on motor unit then refer to *Diagnostic Chart* on the following page.

3. My door reverses for no apparent reason: Repeat safety reverse test after adjustments to force or travel limits. The need for occasional adjustment for the force and limit settings is normal. Weather conditions in particular can affect door travel.

- Manually check door for balance or any binding problems.
- Refer to *Adjustment Step 2, Adjust the Force*.

4. My door reverses for no apparent reason after fully closing and touching the floor: Repeat safety reverse test after adjustments to force or travel limits. The need for occasional adjustment for the force and limit settings is normal. Weather conditions in particular can affect door travel.

- Refer to *Adjustment Step 1, Adjust the UP and DOWN Travel Limits*. Decrease down travel by turning down limit adjustment screw clockwise.

5. My lights will not turn off when door is open:

- The garage door opener is equipped with a security light feature. This feature activates the light on when the safety sensor beam has been obstructed.

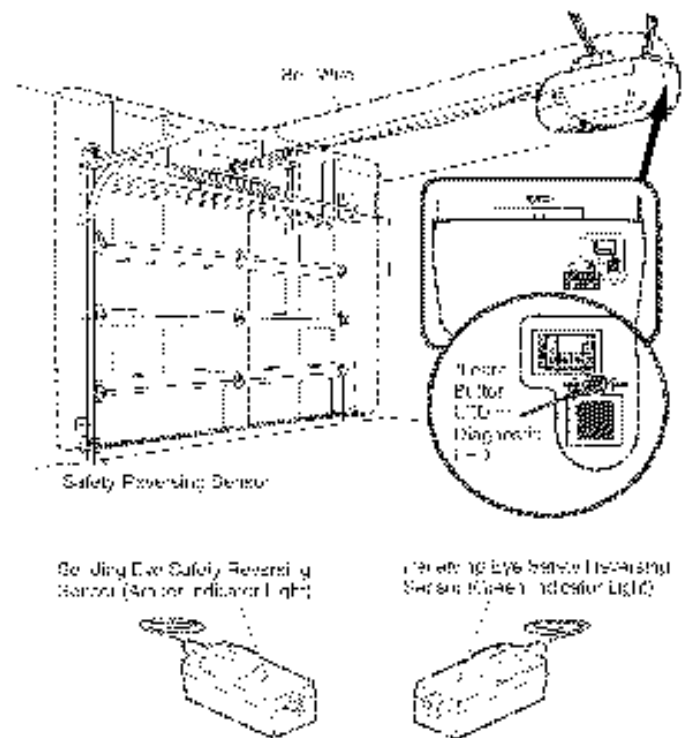

6. My motor unit hums briefly:

- First verify that the trolley is against the stop bolt.
- Release the door from the opener by pulling the Emergency Release Rope.
- Manually bring the door to a closed position.
- Loosen the chain by adjusting the *outer nut* 4 to 5 turns. This relieves the tension.
- Run the motor unit from the remote control or door control. The trolley should travel towards the door and stop. If the trolley re-engages with the door, pull the Emergency Release Rope to disengage.
- Decrease the UP travel by turning the UP Travel adjustment screw 2 full turns away from the arrow.
- Re-tighten the outer nut so the chain is a 1/4" (6 mm) above the base of the rail. (When the door is reconnected and closed, the chain will sag. This is normal.)
- If the trolley does not move away from the bolt, repeat the steps above.

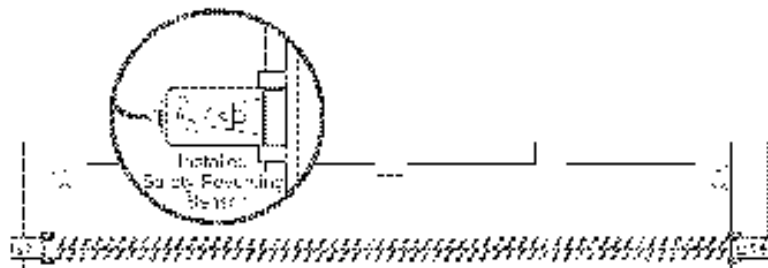
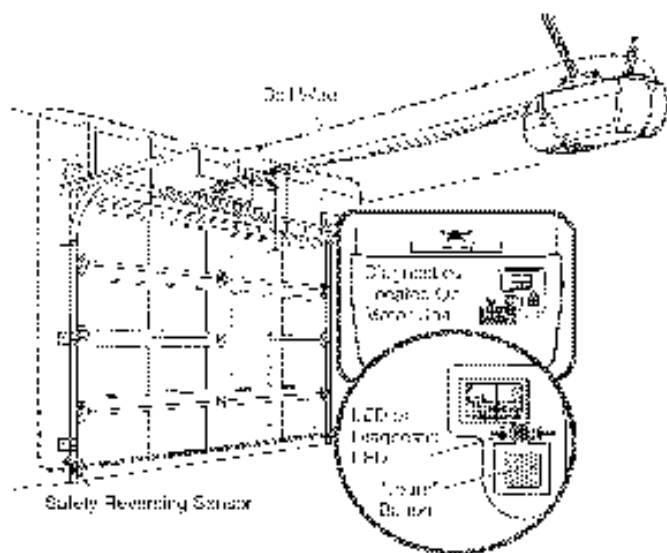

Your garage door opener is programmed with self-diagnostic capabilities. The "Learn" button/diagnostic LED will flash a number of times then pause signifying it has found a potential issue. Consult Diagnostic Chart below.

Diagnostic Chart

1 FLASH

Safety reversing sensors wire open (broken or disconnected).

OR

2 FLASHES

Safety reversing sensors wire shorted or black/white wire reversed.

3 FLASHES

Door control or wire shorted.

4 FLASHES

Safety reversing sensors slightly misaligned (dim or flashing LED).

5 FLASHES

Motor overheated or possible RPM sensor failure. Unplug to reset.

6 FLASHES

Motor Circuit Failure. Replace Receiver Logic Board.

- **Symptom: One or both of the Indicator lights on the safety sensors do not glow steady.**
 - Inspect sensor wires for a short (staple in wire), correct wiring polarity (black/white wires reversed), broken or disconnected wires, replace/attach as needed.
 - Disconnect all wires from back of motor unit.
 - Remove sensors from brackets and shorten sensor wires to 1-2 ft (30-60 cm) from back each of sensor.
 - Reattach sending eye to motor unit using shortened wires. If sending eye indicator light glows steadily, attach the receiving eye.
 - Align sensors, if the indicator lights glow replace the wires for the sensors. If the sensor indicator lights do not light, replace the safety sensors.
- **Symptom: LED is not lit on door control.**
 - Inspect door control/wires for a short (staple in wire), replace as needed.
 - Disconnect wires at door control, touch wires together. If motor unit activates, replace door control.
 - If motor unit does not activate, disconnect door control wires from motor unit. Momentarily short across red and white terminals with jumper wire. If motor unit activates, replace door control wires.
- **Symptom: Sending indicator light glows steadily, receiving indicator light is dim or flashing.**
 - Realign receiving eye sensor, clean lens and secure brackets.
 - Verify door track is firmly secured to wall and does not move.
- **Symptom: Motor has overheated; the motor unit does not operate or trolley is stuck on stop bolt = Motor unit hums briefly; RPM Sensor = Short travel 6-8" (15-20 cm).**
 - Unplug unit to reset. Try to operate motor unit, check diagnostic code.
 - If it is still flashing 5 times and motor unit moves 6-8" (15-20 cm), replace RPM sensor.
 - If motor unit doesn't operate, motor unit is overheated. Wait 30 minutes and retry. If motor unit still will not operate replace logic board.
- **Symptom: Motor unit doesn't operate.**
 - Replace logic board because motor rarely fails.

PROGRAMMING

NOTICE: If this Security+® garage door opener is operated with a non-rolling code transmitter, the technical measure in the receiver of the garage door opener, which provides security against code-theft devices, will be circumvented. The owner of the copyright in the garage door opener does not authorize the purchaser or supplier of the non-rolling code transmitter to circumvent that technical measure.

Your garage door opener has already been programmed at the factory to operate with your hand-held remote control. The door will open and close when you press the large push button.

Below are instructions for programming your opener to operate with additional Security+® remote controls.

To Add or Reprogram a Hand-held Remote Control

USING THE "LEARN" BUTTON

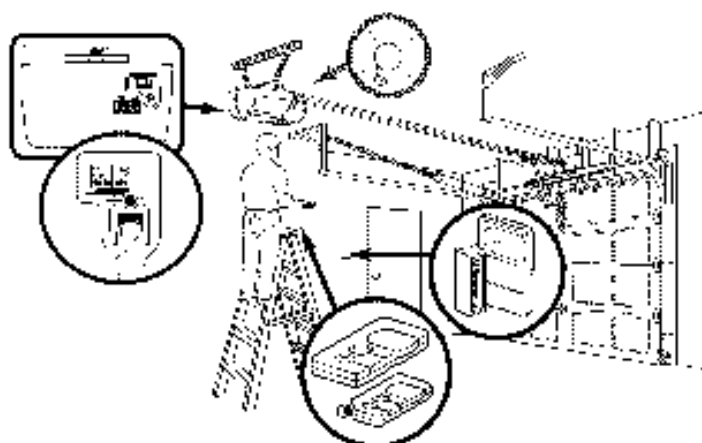

1. Press and release the "learn" button on the motor unit. The learn indicator light will glow steadily for 30 seconds.
2. Within 30 seconds, press and hold the button on the hand-held remote that you wish to operate your garage door.
3. Release the button when the motor unit lights blink. It has learned the code. If light bulbs are not installed, two clicks will be heard.

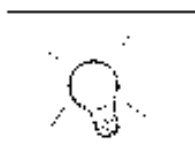
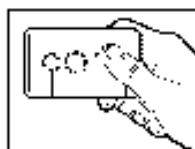

To Erase All Codes From Motor Unit Memory

To deactivate any unwanted remote, first erase all codes:

Press and hold the "learn" button on motor unit until the learn indicator light goes out (approximately 6 seconds). All previous codes are now erased. Reprogram each remote or keyless entry you wish to use.



*3-Function Remotes

If provided with your garage door opener, the large button is factory programmed to operate it. Additional buttons on any Security+® 3-Function remote or compact remote can be programmed to operate other Security+® garage door openers.



To Add, Reprogram or Change a Keyless Entry PIN

NOTE: Your new Keyless Entry must be programmed to operate your garage door opener.

USING THE "LEARN" BUTTON

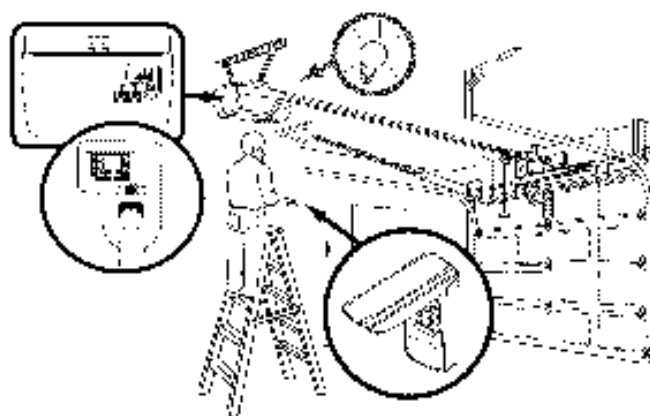

1. Press and release the "learn" button on motor unit. The learn indicator light will glow steadily for 30 seconds.



2. Within 30 seconds, enter a four digit personal identification number (PIN) of your choice on the keypad. Then press and hold the ENTER button.

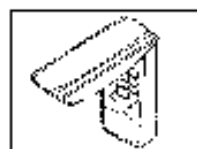

3. Release the button when the motor unit lights blink. It has learned the code. If light bulbs are not installed, two clicks will be heard.

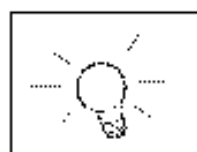

To change an existing, known PIN

If the existing PIN is known, it may be changed by one person without using a ladder.

1. Press the four buttons for the present PIN, then press and hold the * button.

The opener light will blink twice. Release the * button.

2. Press the new 4-digit PIN you have chosen, then press Enter.

The motor unit lights will blink once when the PIN has been learned.

Test by pressing the new PIN, then press Enter. The door should move.

To set a temporary PIN

You may authorize access by visitors or service people with a temporary 4-digit PIN. After a programmed number of hours or number of accesses, this temporary PIN expires and will no longer open the door. It can be used to close the door even after it has expired. To set a temporary PIN:

1. Press the four buttons for your personal entry PIN (not the last temporary PIN), then press and hold the * button.

The opener light will blink three times. Release the button.

2. Press the temporary 4-digit PIN you have chosen, then press Enter.

The opener light will blink four times.

3. To set the number of **hours** this temporary PIN will work, press the number of hours (up to 255), then press *.

OR

3. To set the number of **times** this temporary PIN will work, press the number of times (up to 255), then press #.

The opener light will blink once when the temporary PIN has been learned.

Test by pressing the four buttons for the temporary PIN, then press Enter. The door should move. If the temporary PIN was set to a certain number of openings, remember that the test has used up one opening. To clear the temporary password, repeat steps 1-3, setting the number of hours or times to 0 in step 3.

One Button Close: Opener can be closed by pressing only the ENTER button if the one button close feature has been activated. This feature has been activated at the factory. To activate or deactivate this feature press and hold buttons 1 and 9 for 10 seconds. The keypad will blink twice when the one button close is active. The keypad will blink four times when one button close is deactivated.

REPAIR PARTS

Rail Assembly Parts

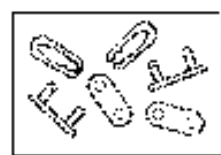

1



2

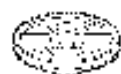

4

3

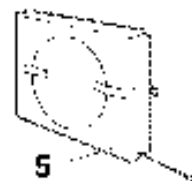

5



6

KEY NO.	PART NO.	DESCRIPTION
1	4A1008	Master link kit
2	41C5141-1	Complete trolley assembly
3	41A5665-2	Complete rail
4	144C56	Idler pulley
5	41A5807	Chain and cable
6	12D598-1	"U" bracket
		NOT SHOWN
	183A163	Wear pads

Installation Parts



1



2



3



4

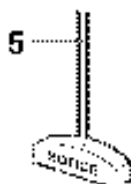

5



7



6



9



8

10



10

11



12



13

KEY NO.	PART NO.	DESCRIPTION
1	41A4899	Standard control console
2	10A20	3V 2032 Lithium battery
3	41A6140-3	3-function remote control housing (no circuit board)
4	29B137	Visor clip
5	41A2828	Emergency release rope and handle assembly
6	41A5047-2	Header bracket w/clevis pin and fastener
7	41B4494-1	2-Conductor bell wire: white and white/red
8	41A5047	Door bracket w/clevis pin and fastener
9	178B35	Curved door arm section
10	178B34	Straight door arm section
11	12B776	Hanging bracket
12	41A5034	Safety sensor kit: receiving and sending eyes with 3' (.9 m) 2-conductor bell wire attached
13	41A5266-1	Safety sensor bracket
		NOT SHOWN
	41A5258-10	Installation hardware bag (includes hardware listed on page 7)
	114A3392	Owner's manual

Motor Unit Assembly Parts

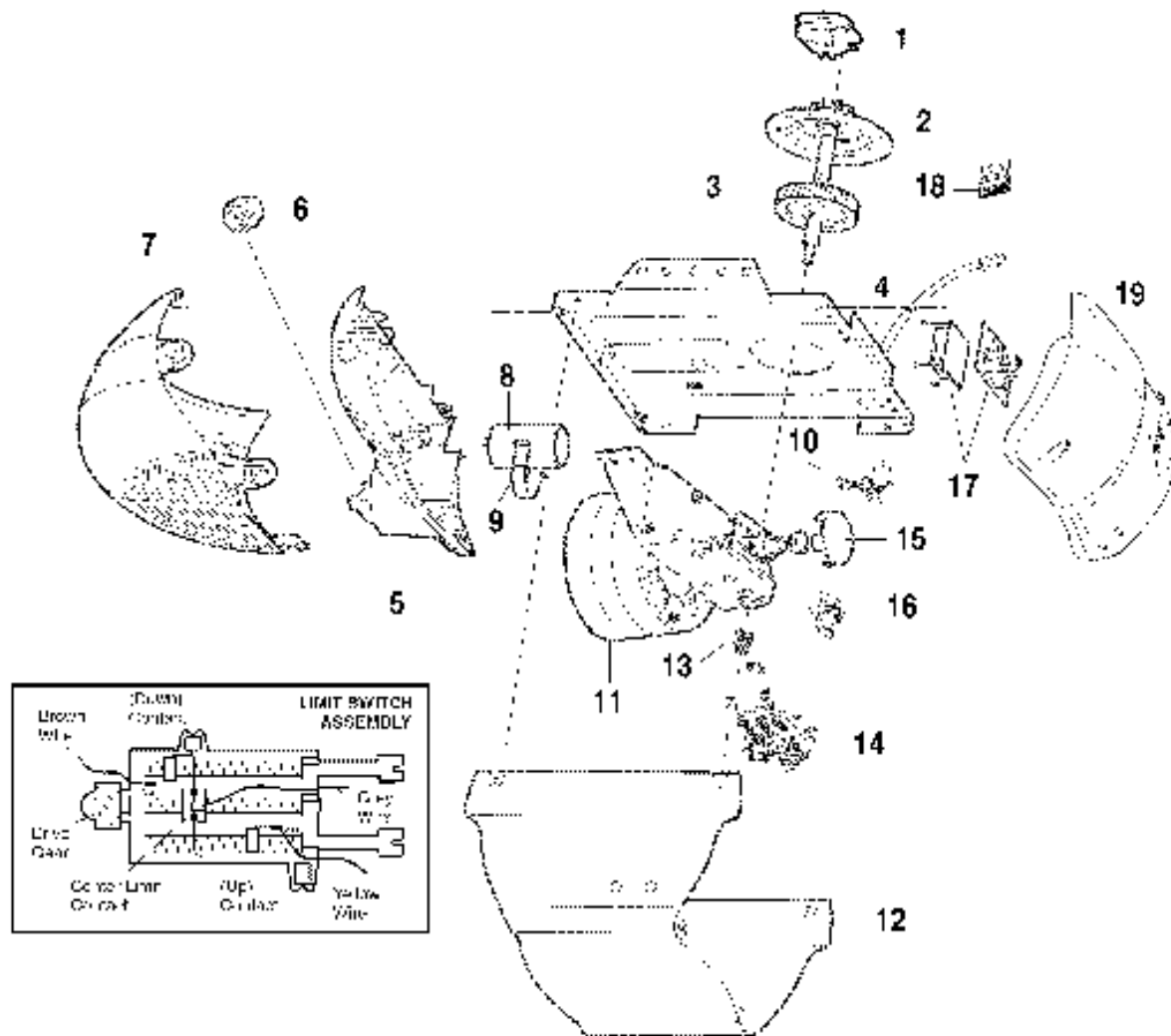

KEY NO.	PART NO.	DESCRIPTION	KEY NO.	PART NO.	DESCRIPTION
1	41A5615	Chain Spreader	12	41A5525-63	Cover
2	41C4220A	Gear and sprocket assembly Complete with: Spring washer, thrust washer, retaining ring, bearing plate, roll pins (2), drive gear and worm gear, helical gear w/retainer and grease	13	41A2618	Limit switch drive & retainer
3	41A2817	Drive/worm gear kit w/grease, roll pins (2)	14	41D3452	Limit switch assembly
4	41B4245	Line cord	15	41A2822-1	Interrupter cup assembly
5	41A5484-5	End panels w/all labels	16	41C4398A	RPM sensor assembly
6	4A1344	Light socket	17	41AC150-1	Receiver logic board assembly. Complete with: Logic board, end panel w/all labels, light socket
7	108D77	Lens	18	41C5497	High voltage wire harness
8	30B532	Capacitor - 1/2 HP		41C5498	Low voltage wire harness
9	12A373	Capacitor bracket	19	41D179	End panel w/all labels
10	41A3150	Terminal block w/screws			NOT SHOWN
11	41D305B	Universal replacement motor & bracket assembly. Complete with: Motor, worm, bracket, bearing assembly, RPM sensor		41A2826	Motor shaft bearing kit
				41A2825	Opener assembly hardware kit (includes screws not designated by a number in illustration)

ACCESSORIES

139.53702

Emergency Key Release:

Required for a garage with NO access door. Enables homeowner to open garage door manually from outside by disengaging trolley.



139.53726

8 Foot (2.4 m) Rail Extension

To allow an 8 (2.4 m) foot door to open fully.

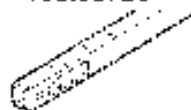

139.53727

10 Foot (3 m) Rail Extension:

To allow a 10 (3 m) foot door to open fully.



139.53589

Support Brackets:

For finished ceilings or where additional support is required, based on garage construction. Includes brackets and fastening hardware.



41A5281

Extension Brackets:

(Available only through Sears Parts & Service)

(Optional) For safety sensor installation onto the wall or floor.



139.53709

Door Clearance Brackets:

(For Sectional Doors Only)

Replaces top brackets and rollers on door to reduce height of door travel. For use when installing opener in garage with low headroom clearance.



139.53753

Security+™ 3-Function Remote Control:

Includes visor clip.



139.53752

Security+™ Compact 3-Function Remote Control:

With loop for attaching key ring.



139.53754

Security+™ Keyless Entry:

Enables homeowner to operate garage door opener from outside by entering a 4 digit code on specially designed keypad.



139.53687

Premium Control Console:

Provides a lock feature to prevent operation of garage door from portable remotes. A light feature controls the opener lights. Can be used to program the opener to accept additional remotes.



139.53749

Plug-In Light Control:

Enables homeowner to turn on a lamp, television or other appliance from car, bedside, or anywhere in the home with a remote.



WARRANTY

CRAFTSMAN GARAGE DOOR OPENER LIMITED WARRANTY

90-DAY IN-HOME FULL WARRANTY ON PRODUCT

For 90 days from the date of purchase, this product will be repaired, free of charge, if defective in material or workmanship.

ADDITIONAL LIMITED WARRANTY ON PARTS

From the 91st day up to 1 year from the date of purchase, replacement parts for any defective parts on this product will be furnished. Fee of charge. You pay for labor.

ADDITIONAL LIMITED WARRANTY ON MOTOR

From the 91st day and through 4 years, if the motor on this product is defective, a replacement motor will be furnished free of charge. You pay for labor.

WARRANTY RESTRICTION

This Craftsman Garage Door Opener Limited Warranty does not cover light bulbs or repair parts necessary because of use, abuse, or negligence, including the failure to install, adjust and operate this garage door opener according to instructions contained in the owner's manual. This limited warranty also does not cover any problems caused by interference.

LIMITATION ON LIABILITY

Seller will not be liable for loss or damage to property or any incidental or consequential loss or expense from property damage due directly or indirectly to the use of this product. Some states do not allow the exclusion or limitation of incidental or consequential damages, so the above limitation or exclusion may not apply to you.

DISCLAIMER OF IMPLIED WARRANTIES

Except for the motor, all implied warranties for this product, including but not limited to any implied warranties of merchantability and fitness for a particular purpose, are limited in duration to the 91st day through 1-year limited warranty period set forth above. All implied warranties with respect to the motor are limited in duration to the 91st day through 4-year limited warranty period set forth above. No implied warranties will exist or apply after such periods. Some States do not allow limitations on how long an implied warranty lasts, so the above limitations may not apply to you.

WARRANTY SERVICE IS AVAILABLE BY CALLING 1-800-4-MY-HOME®.

This warranty applies only while the product is in use in the United States.

This warranty gives you specific legal rights, and you may also have other rights which vary from state to state.

Sears, Roebuck and Co., Dept. 817WA, Hoffman Estates, IL 60179