

CRAFTSMAN 113.244513 OWNER'S MANUAL



Quick Links

[Replacing the Blade](#)

[Tensioning the Blade](#)

[Repair Parts](#)

Table of Contents

Safety instructions

Additional safety instructions for band saw

Before using the saw

When installing or moving the saw

Before each use

Glossary of terms for woodworking

Whenever saw is running

Motor specifications and electrical requirements

Connecting to power supply outlet

Contents

Unpacking and checking contents

Tools needed

Assembly

Mounting band saw to workbench

Table of lose parts

Installing the table

Clamping bandsaw to workbench

Replacing the blade

Tensioning the blade

Compensation for wear

Tracking the blade

Aligning the table square to blade

Adjusting upper blade guide assembly

Adjusting upper blade guides

Adjusting upper thrust bearing
Adjusting lower blade guides
Getting to know your band saw
Product view
Drive belt tension
Adjusting the table
On-Off Switch
Basic band saw operation
Maintenance
Tires
Motor/electrical maintenance
Lubrication
Troubleshooting
Repair parts

SAVE THIS MANUAL
FOR FUTURE
REFERENCE

SEARS

**owners
manual**

**MODEL NO.
113.244513**

Serial
Number
Model and serial
number may be found
at the right-hand side
of the frame.

You should record both
model and serial
number in a safe place
for future use.

CAUTION:

Read **GENERAL** and
**ADDITIONAL SAFETY
INSTRUCTIONS**
carefully

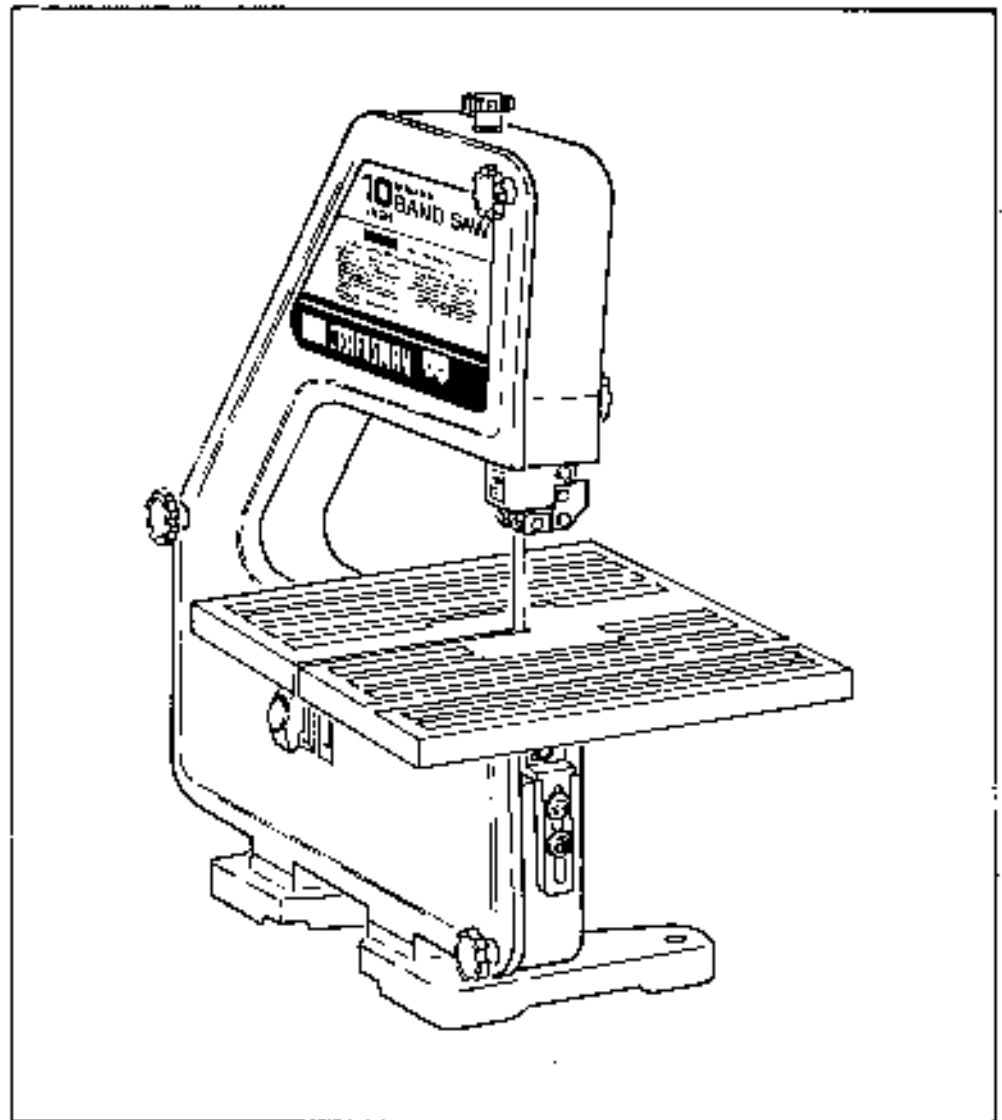

CRAFTSMAN

**10-INCH
BAND SAW**

- **assembly**
- **operating**
- **repair parts**

Sold by SEARS, ROEBUCK AND CO., Chicago, IL. 60684 U.S.A.

FULL ONE YEAR WARRANTY ON CRAFTSMAN BAND SAW

If within one year from the date of purchase, this Craftsman Band Saw fails due to a defect in material or workmanship, Sears will repair it, free of charge.

WARRANTY SERVICE IS AVAILABLE BY SIMPLY CONTACTING THE NEAREST SEARS SERVICE CENTER/DEPARTMENT THROUGHOUT THE UNITED STATES.

THIS WARRANTY APPLIES ONLY WHILE THIS PRODUCT IS USED IN THE UNITED STATES.

This warranty gives you specific legal rights, and you may also have other rights which vary from state to state.

SEARS, ROEBUCK AND CO., 698/731A, Sears Tower, Chicago, IL 60684

general safety instructions for power tools

1. KNOW YOUR POWER TOOL

Read and understand the owner's manual and labels affixed to the tool. Learn its application and limitations as well as the specific potential hazards peculiar to this tool.

2. GROUND ALL TOOLS

This tool is equipped with an approved 3-conductor cord and a 3-prong grounding type plug to fit the proper grounding type receptacle. The green conductor in the cord is the grounding wire. Never connect the green wire to a live terminal.

3. KEEP GUARDS IN PLACE

— in working order, and in proper adjustment and alignment.

4. REMOVE ADJUSTING KEYS AND WRENCHES

Form a habit of checking to see that keys and adjusting wrenches are removed from tool before turning it on.

5. KEEP WORK AREA CLEAN

Cluttered areas and benches invite accidents. Floor must not be slippery due to wax or sawdust.

6. AVOID DANGEROUS ENVIRONMENT

Don't use power tools in damp or wet locations or expose them to rain. Keep work area well lighted. Provide adequate surrounding work space.

7. KEEP CHILDREN AWAY

All visitors should be kept a safe distance from work area.

8. MAKE WORKSHOP CHILD-PROOF

with padlocks, master switches, or by removing starter keys.

9. DON'T FORCE TOOL

It will do the job better and safer at the rate for which it was designed.

10. USE RIGHT TOOL

Don't force tool or attachment to do a job it was not designed for.

11. WEAR PROPER APPAREL

Do not wear loose clothing, gloves, neckties or jewelry (rings, wristwatches) to get caught in moving parts. NONSLIP footwear is recommended. Wear protective hair covering to contain long hair. Roll long sleeves above the elbow.

12. USE SAFETY GOGGLES (Head Protection)

Wear safety goggles (must comply with ANSI

Z87.1) at all times. Everyday eyeglasses only have impact resistant lenses. They are NOT safety glasses. Also, use face or dust mask if cutting operation is dusty and ear protectors (plugs or muffs) during extended periods of operation.

13. SECURE WORK

Use clamps or a vise to hold work when practical. It's safer than using your hands. Free both hands to operate tool.

14. DON'T OVERREACH

Keep proper footing and balance at all times.

15. MAINTAIN TOOLS WITH CARE

Keep tools sharp and clean for best and safest performance. Follow instructions for lubricating and changing accessories.

16. DISCONNECT TOOLS

before servicing, when changing accessories such as blades, bits, cutters, etc.

17. AVOID ACCIDENTAL STARTING

Make sure switch is in "OFF" position before plugging in.

18. USE RECOMMENDED ACCESSORIES

Consult the owner's manual for recommended accessories. Follow the instructions that accompany the accessories. The use of improper accessories may cause hazards.

19. NEVER STAND ON TOOL

Serious injury could occur if the tool is tipped or if the cutting tool is accidentally contacted.

Do not store materials above or near the tool such that it is necessary to stand on the tool to reach them.

20. CHECK DAMAGED PARTS

Before further use of the tool, a guard or other part that is damaged should be carefully checked to ensure that it will operate properly and perform its intended function. Check for alignment of moving parts, binding of moving parts, breakage of parts, mounting, and any other conditions that may affect its operation. A guard or other part that is damaged should be properly repaired or replaced.

21. NEVER LEAVE TOOL RUNNING UNATTENDED

Turn power off. Don't leave tool until it comes to a complete stop.

additional safety instructions for band saw

Safety is a combination of common sense, staying alert, and knowing how your band saw works.

BEFORE USING THE SAW:

WARNING: TO AVOID MISTAKES THAT COULD RESULT IN SERIOUS, PERMANENT INJURY, DO NOT PLUG THE SAW IN UNTIL THE FOLLOWING STEPS HAVE BEEN SATISFACTORILY COMPLETED:

1. Assembly and alignment.
2. Learn the function and proper use of the on-off switch, upper blade guide, lock knob, lower blade guide, tension adjusting knob, table lock knobs, level scale, guide, bar lock knob, and blade thrust bearing adjustment.
3. Read and understand all safety instructions and operating procedures throughout the manual.
4. Read the following items which appear on the front of the band saw and blade guard:

[DANGER] FOR YOUR OWN SAFETY:
READ AND UNDERSTAND MAKER'S MANUAL, BEFORE OPERATING THIS MACHINE

1. ALWAYS WEAR SAFETY GLASSES OR SAFETY GOGGLES TO PROTECT YOUR EYES FROM FLYING CHIPS AND DUST.	2. NEVER USE THE MACHINE WITHOUT THE GUARD.
2. NEVER REACH INTO THE MACHINE TO FEEL FOR A CUTTING TOOL OR TO ADJUST THE GUARD WHILE THE MACHINE IS RUNNING.	3. NEVER USE THE MACHINE TO CUT MATERIALS NOT DESIGNED FOR THIS PURPOSE.
3. NEVER USE THE MACHINE TO CUT MATERIALS NOT DESIGNED FOR THIS PURPOSE.	4. NEVER USE THE MACHINE TO CUT MATERIALS NOT DESIGNED FOR THIS PURPOSE.
4. NEVER USE THE MACHINE TO CUT MATERIALS NOT DESIGNED FOR THIS PURPOSE.	5. NEVER USE THE MACHINE TO CUT MATERIALS NOT DESIGNED FOR THIS PURPOSE.
5. NEVER USE THE MACHINE TO CUT MATERIALS NOT DESIGNED FOR THIS PURPOSE.	6. NEVER USE THE MACHINE TO CUT MATERIALS NOT DESIGNED FOR THIS PURPOSE.
6. NEVER USE THE MACHINE TO CUT MATERIALS NOT DESIGNED FOR THIS PURPOSE.	7. NEVER USE THE MACHINE TO CUT MATERIALS NOT DESIGNED FOR THIS PURPOSE.
7. NEVER USE THE MACHINE TO CUT MATERIALS NOT DESIGNED FOR THIS PURPOSE.	8. NEVER USE THE MACHINE TO CUT MATERIALS NOT DESIGNED FOR THIS PURPOSE.
8. NEVER USE THE MACHINE TO CUT MATERIALS NOT DESIGNED FOR THIS PURPOSE.	9. NEVER USE THE MACHINE TO CUT MATERIALS NOT DESIGNED FOR THIS PURPOSE.
9. NEVER USE THE MACHINE TO CUT MATERIALS NOT DESIGNED FOR THIS PURPOSE.	10. NEVER USE THE MACHINE TO CUT MATERIALS NOT DESIGNED FOR THIS PURPOSE.

[DANGER]
SAFETY
GLASSES
OR
GOGGLES
ARE
NECESSARY



WHEN INSTALLING OR MOVING THE SAW

1. To avoid injury from unexpected saw movement:
 - a. Bolt or clamp the saw to a sturdy level workbench or stand. Always leave a plenty of room for feeding the workpiece.
 - b. Adjust the table so the table is level and the saw does not rock.
 - c. Bolt the base of stand to the floor if it tends to slip, slide, or move during operations like cutting long, heavy boards.
 - d. Turn saw off and unplug electric cord before moving the saw to a new area.
2. Store and use the band saw indoors.

BEFORE EACH USE

1. Inspect your saw. If any part of this band saw is missing, or bent, or failed in any way, or any electrical components do not work properly, turn the saw off, remove switch key, and unplug the saw. Replace damaged, missing, or failed parts before using the saw again.
2. Wear your work to protect your eyes, hands, face, ears and body.

- a. Do not do layout, assemble, or set up work on the table while the saw is running.
- b. Wear safety goggles (not glasses) that comply with ANSI Z87.1 (shown on package). Using any power tool can result in foreign objects being thrown into the eyes, which can result in permanent eye damage. Safety goggles are available at Sears retail or catalog stores. Use of glasses or use of goggles not in compliance with ANSI Z87.1 could result in severe injury from breakage of the eye protection.

- c. For dusty operations, wear a face shield along with safety goggles.
- d. Use extra caution with large, very small, or awkward workpieces:
 1. Use extra supports (table saw horses, etc.) for any workpieces large enough to tip when not held down to the table top.
 2. Do not feed small pieces that require your finger holding the workpiece to go under the guard area. Use jigs or fixtures to hold the work and keep your hands away from the blade.
 3. When cutting irregularly shaped workpieces, plan your work so it will not pinch the blade. A piece of molding, for example, must lay flat or be held by a fixture or jig that will not act as a lateral block or slip while being cut.
 4. Properly support round material such as dowel rods, or tubing. They have a tendency to roll while being cut, causing the blade to "bite." To avoid this, always use a "V" block or clamp the workpiece to a miter gauge.
- e. To avoid risk of hearing damage, wear ear plugs or muffs during extended periods of operation.
- f. To avoid being suddenly caught in the blade:
 1. Do not wear gloves.
 2. Remove all jewelry and loose clothing.
 3. Tie back long hair.
 4. Roll long sleeves above the elbows.
- g. To avoid injury from accidental starting, always unplug saw, turn switch off, and remove switch key before removing the guard, installing or removing any blade, accessory or attachment, or making any adjustments.
- h. To avoid slips and jams causing injury:
 1. Choose the right size and style blade for the material and the type of cutting you plan to do. Use this band saw to cut any wood, wood-like products and plastic.

2. Make sure the blade teeth point downward toward the table.
 3. Make sure the blade tracking guides and thrust bearings are properly adjusted.
 4. Always check and correctly adjust blade tension.
- i. To avoid accidental blade contact, minimize blade breakage and provide maximum blade support:
 1. Always adjust the upper blade guide and blade guard to just clear the workpiece.
 2. Plan your hand placement so your fingers will not be where a sudden slip could cause them to hit the blade.
 - j. Make sure all clamps and knobs are tight and there is no excessive play in any parts.
 - k. To avoid an electrical shock, make sure your fingers do not touch the metal prongs on the plug when installing or removing the plug to or from a live outlet.
 - l. Never turn your band saw "ON" before clearing everything except the workpiece and related loc or support devices off the table.

- a. If your saw makes an unfamiliar noise or if it vibrates excessively, stop immediately. Turn the saw off. Remove switch key and unplug the saw. Do not restart until finding and correcting the problem.
- b. Avoid awkward hand positions where a sudden slip could cause a hand to move into the blade.
- c. Feed the workpiece only fast enough to let the blade cut without bogging down or binding.
- d. Before feeding jammed material, turn saw off. Remove switch key. Remove plug from power source outlet. Wait for all moving parts to stop.
- e. When backing up the workpiece, the blade may bind in the kerf cut. This is usually caused by sawdust clogging up the kerf or because the blade comes out of the guides. If this happens,
 1. Turn saw off.
 2. Unplug saw.
 3. Remove switch key.
 4. Wait for all moving parts to stop.
 5. Remove band saw cover.
 6. Stick a flat blade screwdriver or wedge into the kerf.
 7. Turn the upper wheel by hand using your palm while backing up the workpiece.
- f. Before removing loose pieces from the table, turn saw off and wait for all moving parts to stop.
- g. To avoid injury from untested or improper accessories, use only Recommended Accessories listed on the Accessory page of this manual.

WHENEVER SAW IS RUNNING

WARNING: DO NOT ALLOW FAMILIARITY (GAINED FROM FREQUENT USE OF YOUR BAND SAW) TO CAUSE A CARELESS MISTAKE. ALWAYS REMEMBER THAT A CARELESS FRACTION OF A SECOND IS SUFFICIENT TO INFLECT SEVERE INJURY.

glossary of terms for woodworking

Beveling

An angle cutting operation through the face of the board.

Crosscut

A cutting operation made across the width of the workpiece.

Compound Cutting

A simultaneous bevel and miter cutting operation.

FPM

Feet per minute. Used in reference to surface speed of blade.

Freehand (as used for band saw)

Performing a cut without the workpiece properly supported on the work table.

Gum

A sticky, sap-based residue from wood products.

Kerf

The material removed by the blade in a through cut or the slot produced by the blade in a non-through or partial cut.

Leading End

The end of the workpiece which is pushed into the cutting tool first.

Mitering

An angle cutting operation made across the width of the workpiece.

Push Stick

A device used to feed the workpiece through the saw during narrow ripping type operations so the operator's hands are kept well away from the blade.

Resaw

A cutting operation to reduce the thickness of the workpiece to make thinner pieces.

Resin

A sticky, sap-based substance that has dried.

Ripping

A cutting operation along the length of the workpiece.

Sawblade Path

The area of the worktable or workpiece directly in line with the saw blade.

Set

The distance the tip of the saw blade tooth is bent outward from the face of the blade.

Trailing End

The workpiece end last cut by the saw blade.

Workpiece

The item on which the cutting operation is being performed. The surfaces of a workpiece are commonly referred to as faces, ends, and edges.

Worktable

The surface on which the workpiece rests while performing a cutting operation.

motor specifications and electrical requirements

This machine is designed to use, and is equipped with, a 1725 RPM motor. It is wired for operation on 120 volts, 60 Hz., alternating current. (TOOL MUST NOT BE CONVERTED TO OPERATE ON 230 VOLT).

For replacement motor refer to parts list in this manual.

CONNECTING TO POWER SUPPLY OUTLET

This machine must be grounded while in use to protect the operator from electric shock.

Plug power cord into a 120V properly grounded type outlet protected by a 15-amp fuse or circuit breaker.

If you are not sure that your outlet is properly grounded, have it checked by a qualified electrician.

WARNING: DO NOT PERMIT FINGERS TO TOUCH THE TERMINALS OF PLUGS WHEN INSTALLING OR REMOVING THE PLUG TO OR FROM THE OUTLET.

WARNING: IF NOT PROPERLY GROUNDED THIS POWER TOOL CAN CAUSE AN ELECTRICAL SHOCK PARTICULARLY WHEN USED IN DAMP LOCATIONS CLOSE TO PLUMBING. IF AN ELECTRICAL SHOCK OCCURS THERE IS THE POTENTIAL OF A SECONDARY HAZARD SUCH AS YOUR HANDS CONTACTING THE SAW BLADE.

If power cord is worn or cut, or damaged in any way, have it replaced immediately.

Your unit is for use on 120 volts, and has a plug that looks like below:

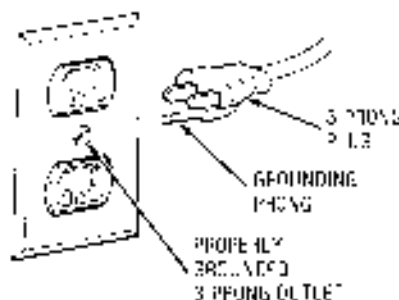

This power tool is equipped with a 3-conductor cord and grounding type plug which has a grounding prong, approved by Underwriters' Laboratories and the Canadian Standards Association. The ground conductor has a green jacket and is attached to the tool housing at one end and to the ground prong in the attachment plug at the other end.

This plug requires a mating 3-conductor grounded type outlet as shown.

If the outlet you are planning to use for this power tool is of the two prong type, DO NOT REMOVE OR ALTER THE GROUNDING PRONG IN ANY MANNER. Use an adapter as shown below and always connect the grounding lug to a known ground.

It is recommended that you have a qualified electrician replace the TWO prong outlet with a properly grounded THREE prong outlet.

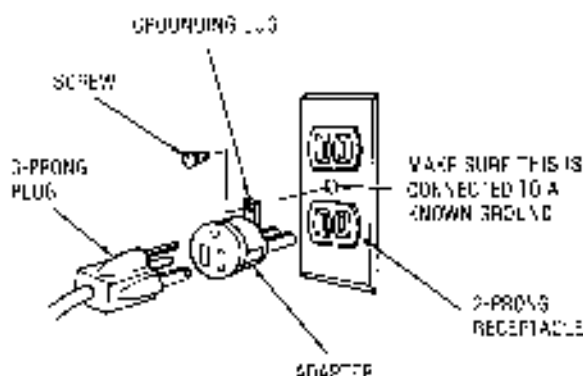

An adapter as illustrated is available for connecting plugs to 2-prong receptacles. The green grounding lug extending from the adapter must be connected to a permanent ground such as to a properly grounded outlet box.

NOTE: The adapter illustrated is for use only if you already have a properly grounded 2-prong receptacle. Adapter is not allowed in Canada by the Canadian Electrical Code.

The use of any extension cord will cause some loss of power. To keep this to a minimum and to prevent overheating and motor burn-out, use the table below to determine the minimum wire size (A.W.G.) extension cord.

Use only 3 wire extension cords which have 3-prong grounding type plugs and 3-prong receptacles which accept the tools plug.

Length of the Conductor	Wire Sizes Required (American Wire Gage Number) 120V Lines
0 - 25 Feet	No. 16
26 - 50 Feet	No. 14
51 - 100 Feet	No. 12

contents

CONTENTS

POWER TOOL WARRANTY	2	Adjusting Lower Blade Guides.	12
GENERAL SAFETY INSTRUCTIONS FOR POWER TOOLS	2	Drive Belt Tension	13
ADDITIONAL SAFETY INSTRUCTIONS FOR BAND SAW	3	Adjusting Table	13
MOTOR SPECIFICATIONS AND ELECTRICAL REQUIREMENTS.....	5	GETTING TO KNOW YOUR BAND SAW	
UNPACKING AND CHECKING CONTENTS	8	Tension Adjustment Knob.....	14
ASSEMBLY		Cover Knobs.....	14
Mounting Band Saw to Workbench.....	7	Blade Guides	14
Clamping Band Saw to Workbench.....	8	Tension Lock Knob	14
Installing the Table.....	8	Guide Bar Lock Knob	14
Installing the Blade	9	Table Lock Knobs.....	14
Tensioning the Blade.....	10	Bevel Scale.....	14
Tracking the Blade	11	On-Off Switch	14
Adjusting the Table Square to Blade	11	BASIC BAND SAW OPERATION	
Adjusting Upper Blade Guide Assembly.....	12	Sawing	15
Adjusting Upper Blade Guides.....	12	MAINTENANCE.....	16
Adjusting Upper Thrust Bearing	12	Lubrication	16
Adjusting Lower Blade Guide Assembly.....	12	RECOMMENDED ACCESSORIES	16
		TROUBLESHOOTING	17
		REPAIR PARTS	16

unpacking and checking contents

TOOLS NEEDED

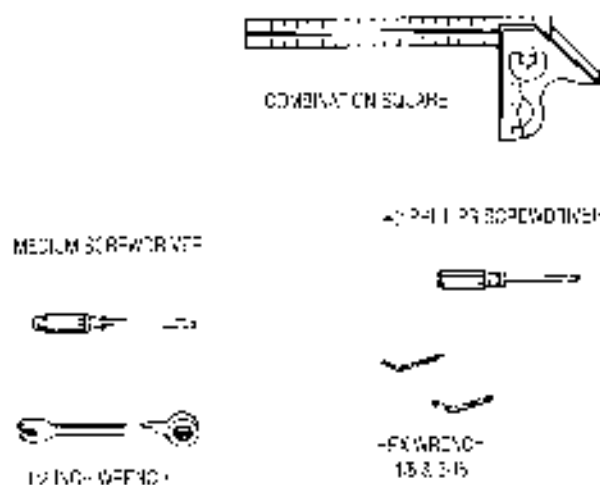

COMBINATION SQUARE MUST BE TRUE

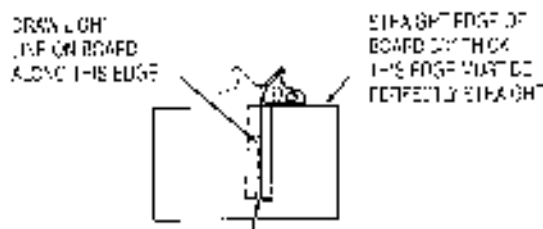

WARNING: FOR YOUR OWN SAFETY, NEVER CONNECT PLUG TO POWER SOURCE OUTLET UNTIL ALL ASSEMBLY STEPS ARE COMPLETE, AND YOU HAVE READ AND UNDERSTAND THE SAFETY AND OPERATIONAL INSTRUCTIONS.

Model 113.244513 Band Saw is shipped complete in one carton.

Separate all parts from packing materials and check each item with illustration and "Table of Loose Parts". Make certain all items are accounted for, before discarding any packing material.

WARNING: IF ANY PARTS ARE MISSING, DO NOT TRY TO ASSEMBLE THE BAND SAW, PLUG IN THE POWER CORD, OR TURN THE SWITCH ON UNTIL THE MISSING PARTS ARE OBTAINED AND INSTALLED CORRECTLY.

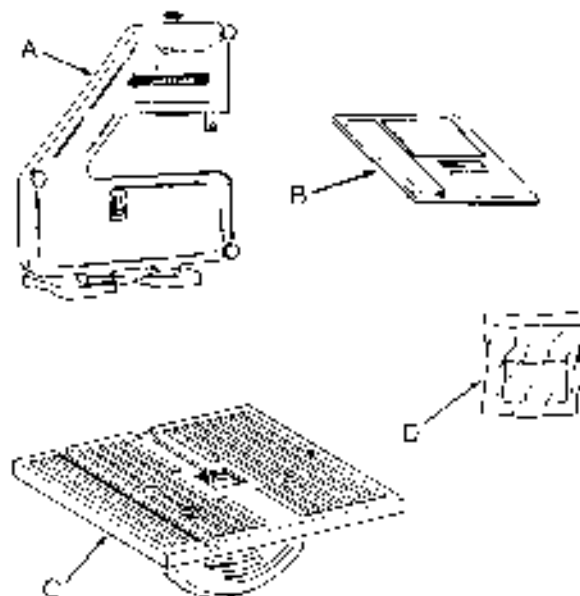

ITEM	TABLE OF LOOSE PARTS	QTY.
A	Basic saw assembly	1
B	Owners Manual	1
C	Saw Table assembly	1
D	Bag Assembly Part #69185	
	Containing the following parts:	
	Switch, Key	1
	Nut, Wing 1/4-20	1
	Screw, Truss Hd. 1/4-20 x 3/4	1
	Washer 17/64 x 5/8 x 1/16	1
	Washer 17/64 x 47/64 x 1/16	2
	Indicator, Bevel	1
	Screw, Pan Cross 10-24 x 1/4	1
	Insert, Table	-
	Knob	2

assembly

MOUNTING BAND SAW TO WORKBENCH

If band saw is to be used in a permanent location, it should be fastened securely to a firm supporting surface such as a workbench.

If mounting to a workbench, holes should be drilled through supporting surface of the workbench using dimensions illustrated.

1. Each leg should be drilled securely using 5/16" diameter machine screws, lockwashers, and 5/16" hex nuts (not included). Screw length should be 1 1/2" plus the thickness of the bench top.
2. Locate and mark the holes where band saw is to be mounted.
3. Drill 1/4" diameter holes through workbench.
4. Place band saw on workbench aligning holes in feet with holes drilled in workbench.
5. Insert a pair 5/16" screws and tighten.

NOTE: Front two mounting bolts should be inserted from the bottom with washer and nut on top.

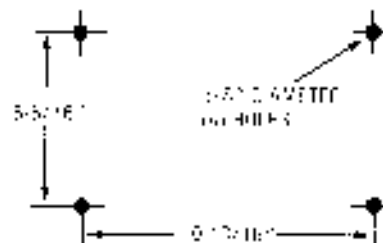

An alternate method of mounting is to fasten band saw to a mounting board. The board should be of sufficient size to avoid tipping of saw while in use. Any good grade of plywood or chipboard with a 3/4" minimum thickness is recommended. (Thinner chipboard can break.)

1. Follow instructions for mounting to workbench, substituting a board 18" x 24" minimum size and using 5/16 inch flat head screws, lockwashers, and hex nuts (not included). Screw length should be 1 1/2" plus the thickness of the mounting board.

NOTE: For proper stability, holes must be counter sunk so screw heads are flush with the bottom surface of supporting board.

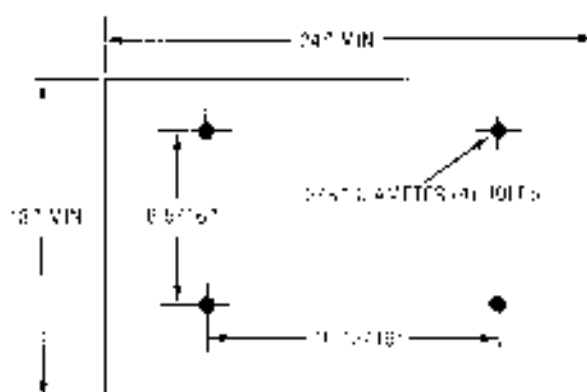

assembly

2. Securely clamp board to workbench using "C" clamps.

NOTE: Supporting surface where band saw is mounted should be examined carefully after mounting to insure that no movement during use can result. If any tipping or walking is noted, secure workbench or supporting surface before operating band saw.

CLAMPING BANDSAW TO WORKBENCH

The Band Saw can be clamped directly to a workbench using two (2) or more "C" clamps on base of unit.

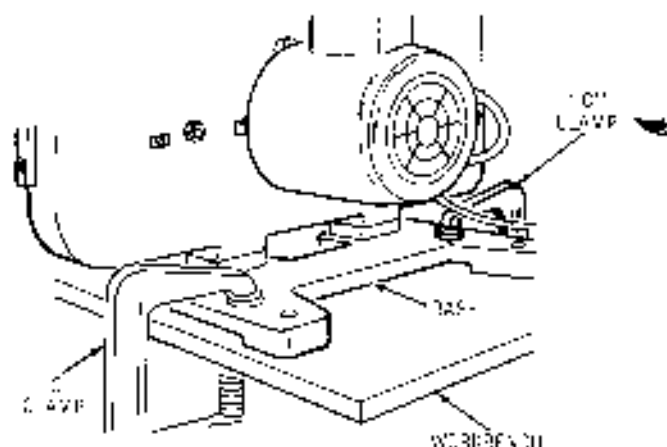

INSTALLING THE TABLE

Apply a coat of automobile wax to the table top and inside surfaces of trunnion that slide on frame.

1. Loosen the guide bar lock knob and position the upper guide assembly all of the way up. Tighten lock knob.

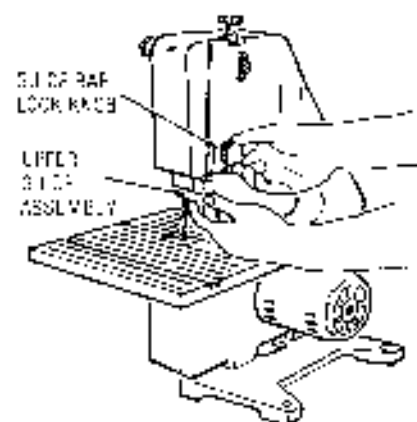

2. Locate two (2) knobs and two (2) 17/64 x 47/64 x 1/16 washers in loose parts bag, and the table assembly in loose parts.
3. Place table assembly onto band saw frame with the trunnion against mounting rib on frame.

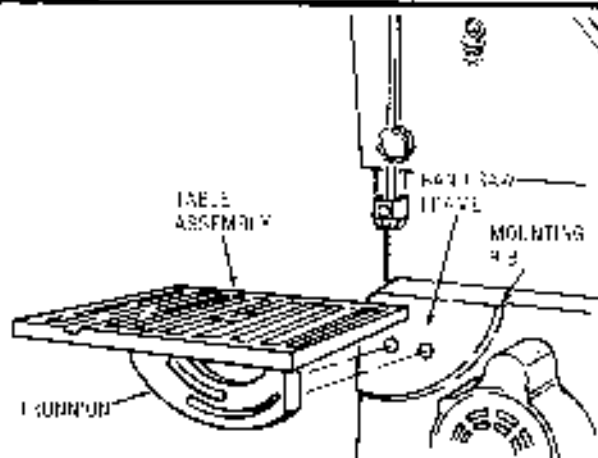

4. Hold table assembly against the frame and install two (2) table lock knobs and washers as shown through the trunnion slots and tighten.

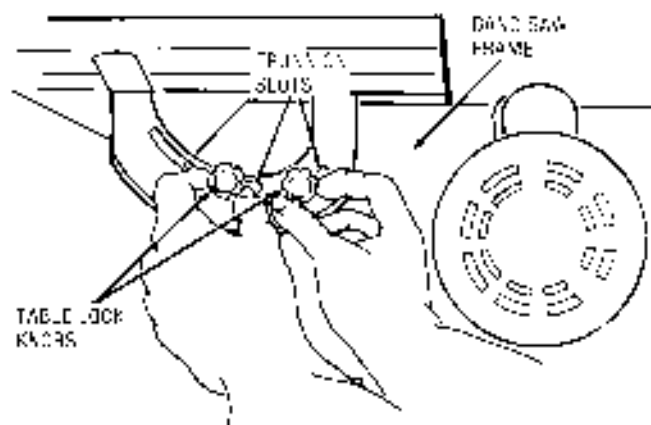

5. Locate bevel indicator and 10-24x1/4 pan cross hd. screw in loose parts bag.
6. Install bevel indicator and screw as shown using a phillips screwdriver.

NOTE: This unit comes with the Band Saw blade installed, assembly continues on p. 10, "Tensioning the Blade."

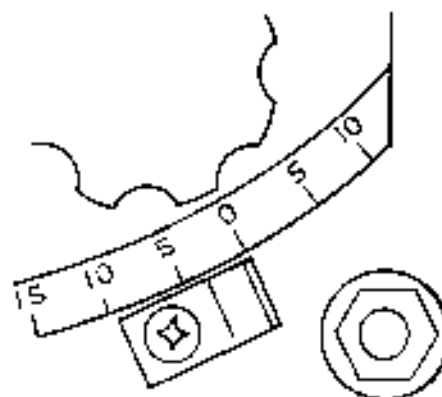

REPLACING THE BLADE

1. Loosen the guide bar lock knob and position the upper guide assembly approximately one inch above the table and tighten lock knob.
2. Loosen the two blade guard mounting screws and remove the blade guard.

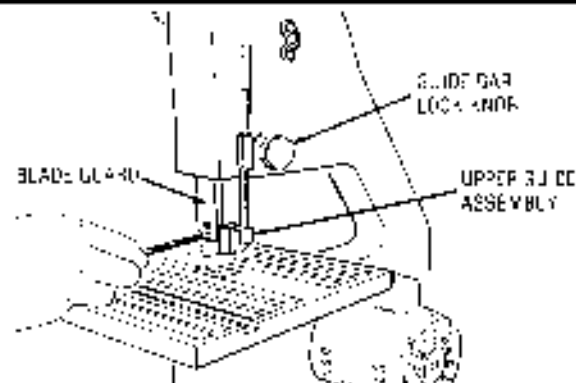

3. Loosen the guide bar lock knob and position the upper guide assembly approximately two inches above the table as shown and tighten the lock knob.
4. Remove table insert, truss head screw, washer and wing nut from the table (See Assembly, p. 12 - "Adjusting the Table"). Replace those parts after the blade is installed, tensioned and tracked.

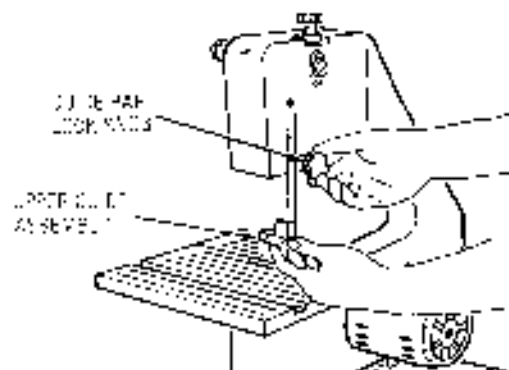

5. Loosen the two screws in the front of the upper blade guide assembly that secure the blade guides and separate them about 1/8".
6. Loosen the two screws in the side of the upper guide assembly and slide guides and thrust bearing all of the way back.
7. Tighten all screws.

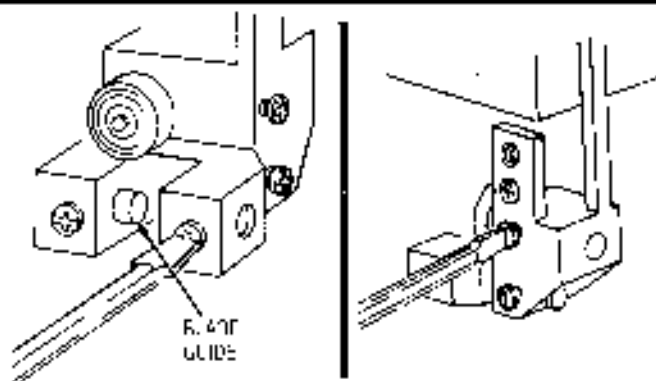

8. Loosen the three (3) cover knobs by turning counterclockwise and remove cover.

NOTE: Replace the bandsaw cover after blade is properly installed, tensioned and tracked.

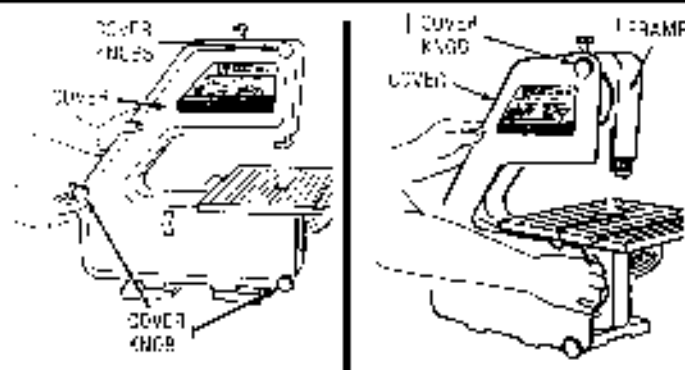

assembly

- Loosen the two screws that secure the lower blade guides and separate them about 1/8".
- Loosen the screw holding the lower blade guide support and slide support all the way toward the rear of the saw, and retighten all screws.

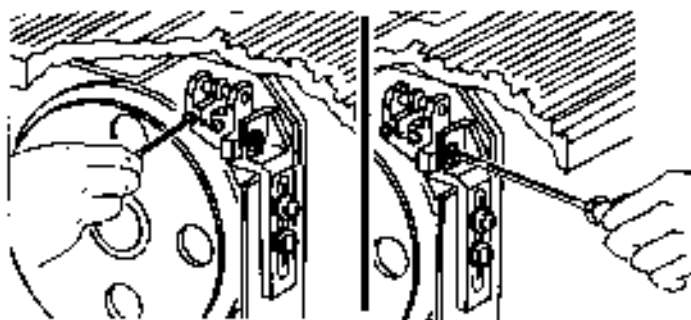

WARNING: TO AVOID BEING SCRAPPED SHOULD BLADE SUDDENLY UNCOIL, WEAR SAFETY GOGGLES AND CAREFULLY UNCOIL THE BLADE HOLDING IT AT ARMS LENGTH.

- Place the blade over the wheels with the teeth pointing downward toward the table as shown. Make sure the blade is in the center of the rubber tires.

NOTE: Your bandsaw can use 1/8 or 1/4 inch wide blades, 56-7/8 inches long. A 1/4 inch blade is included with this saw.

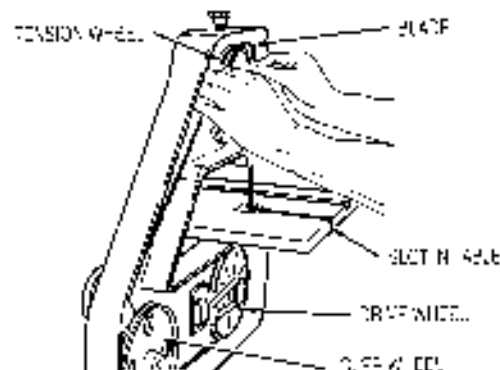

TENSIONING THE BLADE

The bandsaw is equipped with a self-limiting tension device. The tension is factory set and should not need adjustment. The blade must be installed before tension can be set.

- Turn tension adjustment knob until knob contacts washer and sleeve.
- DO NOT turn knob after contact is made and resistance is felt. This is the proper tension setting for a 1/4" blade.
- To release tension turn knob counterclockwise until knob is above the washer and sleeve.

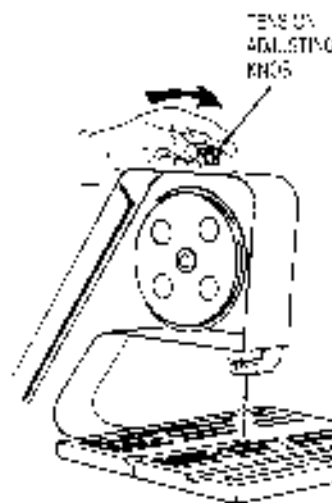

COMPENSATION FOR WEAR

Tension screw is provided to make minimal adjustments due to wear. The tension screw creates a drag between the wheel guide and the frame.

- Remove the blade before adjusting.
- Use a phillips screw driver to adjust the tension screw. Turn clockwise to increase the drag (tension).
- Check tension by lifting up on tension knob. If the tension knob will not move the tension screw is too tight. Adjust by turning tension screw counterclockwise and recheck.

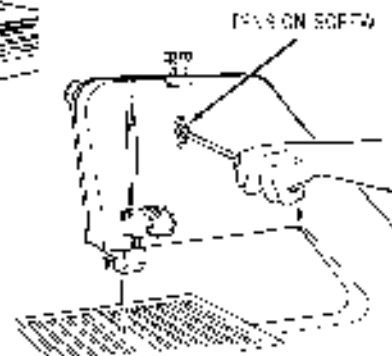

WARNING: OVER TENSION AND FAILURE TO PROPERLY SET BLADE GUIDES AND THRUST BEARING WILL CAUSE PREMATURE BLADE BREAKAGE. FOLLOW ADJUSTING BLADE GUIDE ASSEMBLIES COMPLETELY TO HELP MAINTAIN NORMAL BLADE LIFE.

TRACKING THE BLADE

Tension knob must be tightened before tracking blade.

1. Turn the upper wheel by hand (clockwise) and check if the blade remains in the approximate center of the tires. If the blade moves away from the center of the tires, while you are turning the wheels, adjust as follows:
 - A. Turn the tracking adjustment set screw slightly with a 1/8" hex wrench. (Turning the set screw moves the tension wheel back and forth.)
 - B. If the blade moves toward the front of the band saw:

Turn the tracking adjustment screw clockwise about 1/4 of a turn, as though you were tightening it.

If the blade moves toward the back of the band saw:

Turn the tracking adjustment screw counterclockwise about 1/4 of a turn as though you were loosening it.

Turn the screw just enough to cause the

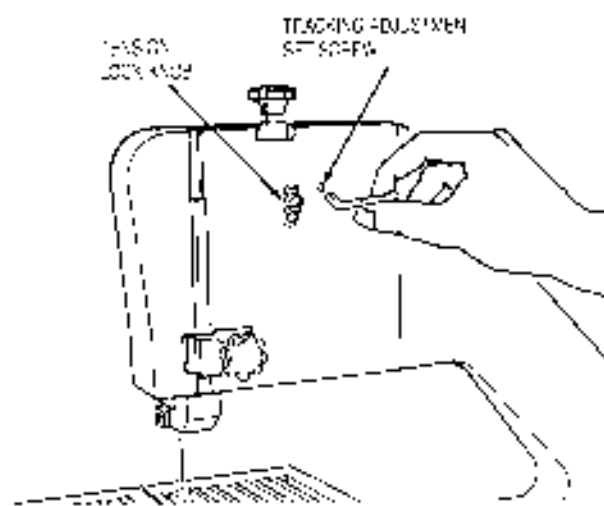

blade to run in the approximate center of all tires.

- C. After adjusting, turn upper wheel by hand clockwise a few turns and notice if the blade remains in the approximate center of the tires, readjust if necessary, until blade is tracking properly.

ALIGNING THE TABLE SQUARE TO BLADE

1. Lower table to zero position.
2. Place a square on the table in front of the blade as illustrated.
3. Turn table adjustment to align table 90 degrees to blade in degree position and tighten lock-nut.
4. Adjust zero stop set screw using a 1/8" hex wrench until set screw just touches frame.
5. Check squareness of blade to table. Make readjustments if necessary.
6. Set bevel and bevel angle to zero.

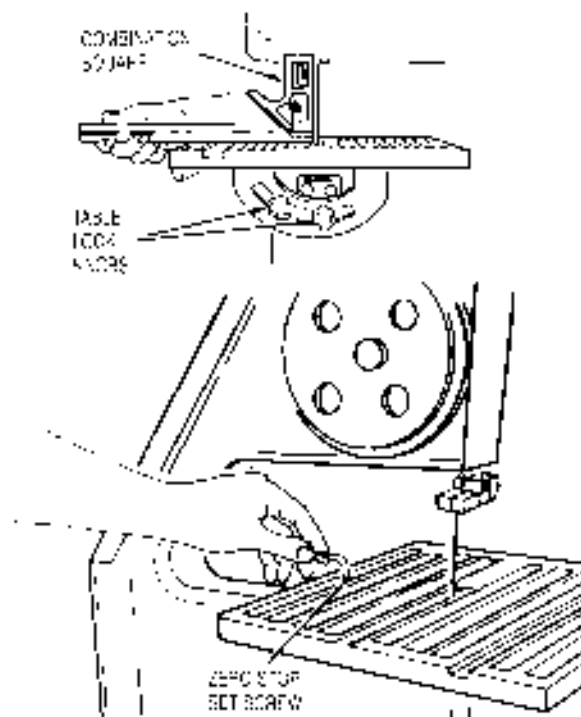

NOTE: When table is tilted to a bevel angle, the lower blade guide support should be lowered to clear the table. After bevel cutting and returning table to zero position, always raise the lower blade guide up to provide maximum support for the blade.

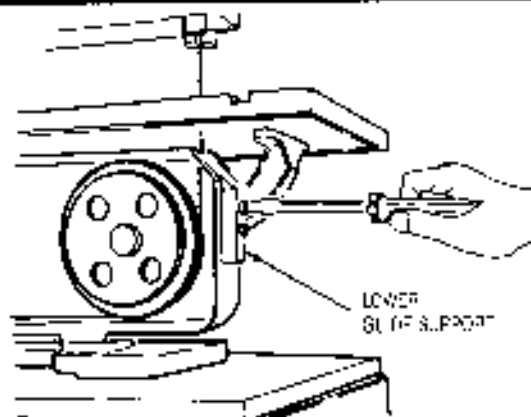

assembly

NOTE: The upper and lower blade guides support the blade and keep it from twisting during operation. An adjustment is necessary when blades are changed, replaced or installed for the first time.

ADJUSTING UPPER BLADE GUIDE ASSEMBLY

1. Loosen lower screw on side of upper blade guide assembly and slide assembly forward until the front edge of the blade guides are approximately $1/32"$ from the GULLET of the saw blade. Tighten screw.

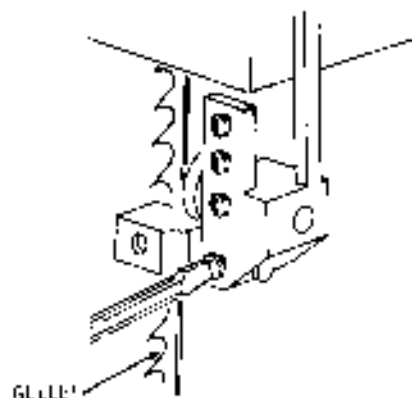

ADJUSTING UPPER BLADE GUIDES

1. Loosen the two screws that lock the upper blade guides and press the two guides evenly against the sides of the blade but do not pinch the blade. Release the guides and rotate the upper wheel slightly clockwise moving the blade downward. Make sure one guide is not further away from the blade than the other. Tighten both screws.

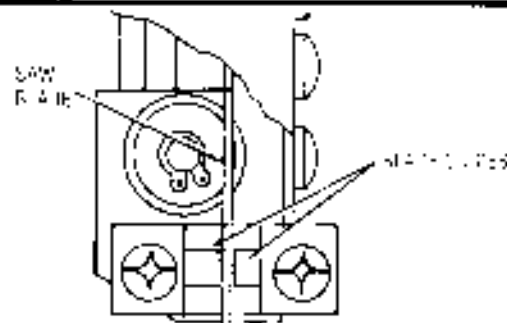

ADJUSTING UPPER THRUST BEARING

NOTE: The thrust bearing supports the blade from the rear and will rotate when the blade is pushed against it while you are cutting. As soon as you stop cutting, the bearing should stop rotating.

1. To adjust, loosen the upper screw on the side of the upper blade guide assembly and slide the bearing forward until it is approximately $1/32"$ from the back of the blade. Tighten screw. Rotate upper wheel slightly clockwise to check clearance. Readjust if necessary.

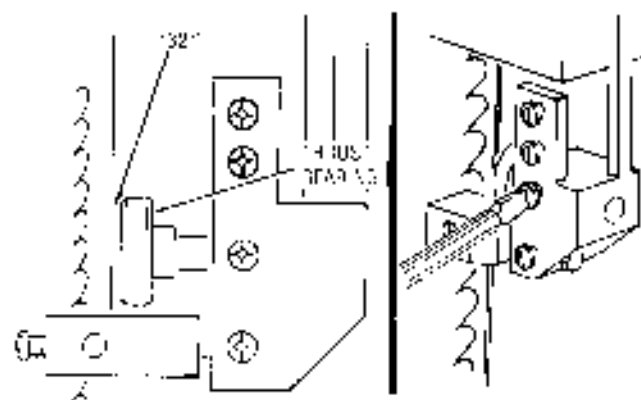

ADJUSTING LOWER BLADE GUIDE ASSEMBLY

1. Loosen the screw (as shown) on the side of the lower blade guide assembly and slide assembly forward until bearing is approximately $1/32"$ from the back of the blade. Blade guides will align with this adjustment. Tighten screw.

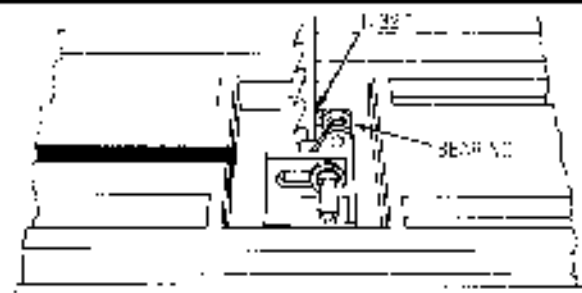

ADJUSTING LOWER BLADE GUIDES

1. Loosen the two screws that lock the lower blade guides and press the two guides evenly against the sides of the blade but do not pinch the blade. Release the guides and rotate the upper wheel slightly clockwise moving the blade downward. Make sure one guide is not further away from the blade than the other. Tighten both screws.

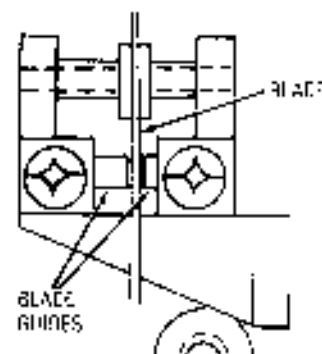

NOTE: After all adjustments have been made, turn the upper wheel by hand (clockwise) a few turns to check blade travel and clearance.

DRIVE BELT TENSION

WARNING: TO AVOID INJURY DUE TO ACCIDENTAL START, UNPLUG TOOL BEFORE MAKING ADJUSTMENTS.

The tension on the drive belt has been set at the factory. If adjustment is needed, use a 3/16" hex wrench to loosen upper and lower cap screws. Pull motor away from drive wheel to apply proper tension to drive belt. Retighten cap screw when holding motor in place.

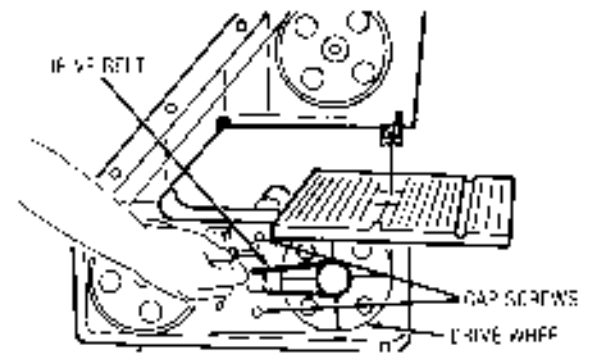

ADJUSTING THE TABLE

1. Replace the blade guard on the upper assembly and tighten screws.
2. Locate the table insert and place it in the opening in the table. Align slot in the insert with the slot in the table.
3. Locate a 1/4" - 20 x 3/4" truss head screw, a flat washer, and a 1/4" - 20 wing nut in loose parts. Insert screw into hole in table top as illustrated.
4. From the underside of the table, install washer and wing nut onto the truss head screw and tighten finger tight. This will keep the table flat and in alignment.
5. Replace the band saw cover.

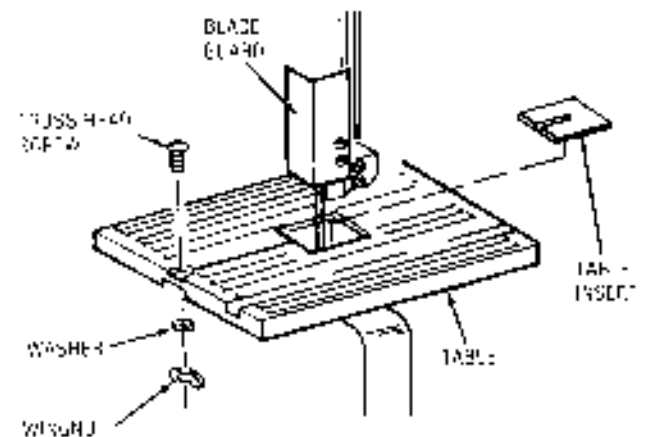

getting to know your band saw

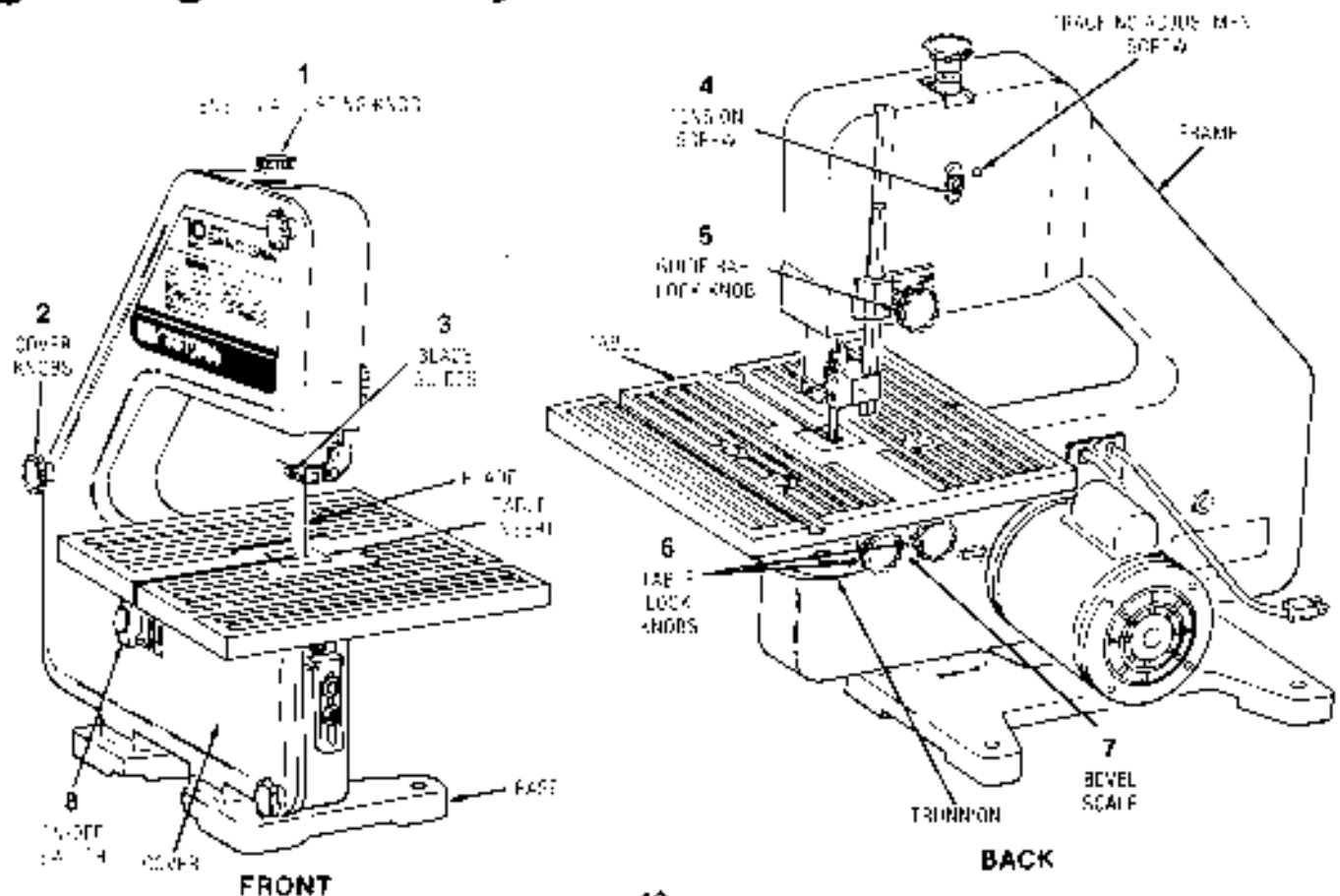

getting to know your band saw

1. Tension adjusting knob... Tightening the knob (clockwise) will increase the tension on the blade. Loosening it (counter clockwise) will decrease the tension. (Tension lock knob must be released).
2. Cover knobs... Secure cover to frame by tightening all three (3) cover knobs.
3. Blade Guides... Supports the blade and keeps it from twisting during operation. An adjustment is necessary when blades are changed or replaced.
4. Tension screw... maintains tension between upper wheel guide and frame.
5. Guide bar lock knob... The upper blade guide assembly should just clear the work piece while cutting. Always adjust the upper blade guide assembly and lock the guide bar by tightening the blade guide lock knob before turning on the band saw.
6. Table lock knobs... Loosening knobs allows the table to be tilted and tightening knobs locks the table in place.
7. Tilt (bevel) scale... Shows degree table is tilted for bevel cutting.

8. **ON-OFF SWITCH.** The On-Off Switch has a locking feature. THIS FEATURE IS INTENDED TO HELP PREVENT UNAUTHORIZED AND POSSIBLY HAZARDOUS USE BY CHILDREN AND OTHERS.

1. To turn machine on insert key into switch.

NOTE: Key is made of yellow plastic; locate in loose parts bag.

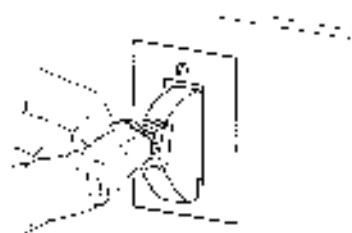

2. Insert finger under switch lever and pull end of switch out.



3. To turn machine OFF... PUSH lever in.

NEVER LEAVE THE MACHINE UNATTENDED UNTIL IT HAS COME TO A COMPLETE STOP.



4. To lock switch in OFF position... hold switch IN with one hand... REMOVE key with other hand.

WARNING: FOR YOUR OWN SAFETY, ALWAYS LOCK THE SWITCH "OFF" WHEN MACHINE IS NOT IN USE... REMOVE KEY AND KEEP IT IN A SAFE PLACE... ALSO... IN THE EVENT OF A POWER FAILURE (ALL OF YOUR LIGHTS GO OUT) TURN SWITCH OFF... REMOVE THE KEY AND STORE IT REMOTE FROM BAND SAW. THIS WILL PREVENT THE MACHINE FROM STARTING UP AGAIN WHEN THE POWER COMES BACK ON.

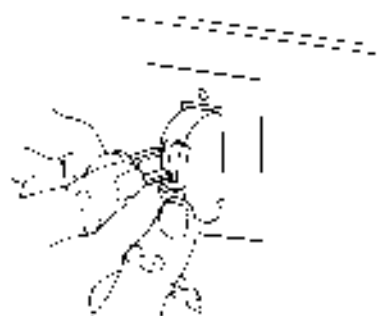

basic band saw operation

A band saw is basically a "curve cutting" machine. It is also used for straight-line cutting operations such as cross cutting, ripping, mitring, beveling, compound cutting, and resawing. It is not capable of doing inside cutting.

This band saw is designed to cut wood and wood like products only.

For general type scroll cutting, follow the pattern lines by pushing and turning the workpiece at the same time. Do not try to turn the workpiece while engaged in the blade without pushing. If the workpiece could bind or twist at the blade.

A curve cut is best performed by keeping the pattern line in line with the blade while turning the workpiece before the radius of the curve is cut. The blade should cut in the middle of the pattern line. **NOTE:** All wood cutting band saw blades are right hand.

NOTE: Blade guard is raised and right hand removed for clarity of picture only.

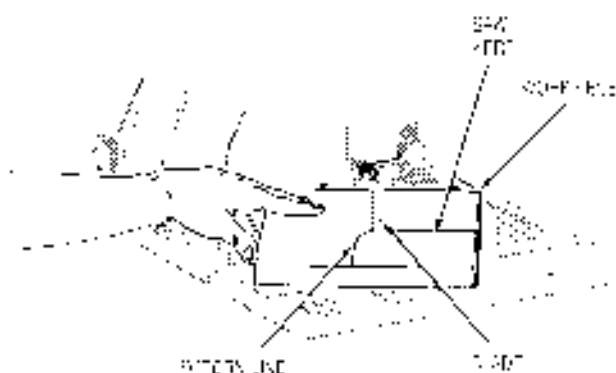

RIGHT - Planning ahead by turning workpiece or cutting a curve.

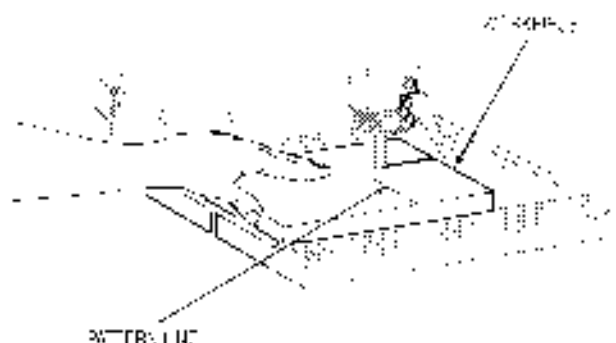

WRONG - Not planning ahead for cutting a curve could bind or twist blade if workpiece is forced.

WARNING: ADJUST THE UPPER GUIDE ASSEMBLY TO JUST CLEAR THE WORKPIECE.

1. Use both hands when loading the work into the blade. Hold the workpiece firmly against the table. Use gentle pressure. Do not force the work, but allow the blade to cut.
2. The size and number of curves that can be cut out is determined by the width of the blade. A 1 1/2" wide blade can cut out a curve with a diameter of approximately 1 1/2".

Relief cuts are made when an intricate curve (too small a radius) that a band blade is to be cut. A relief cut is made by cutting through scrap section of workpiece to curve in pattern line, then carefully backing blade out. Several relief cuts should be made for intricate curves, then follow pattern line as sections are cut off of curve "relieving" blade pressure.

NOTE: Blade guard is raised and right hand removed for clarity of picture only.

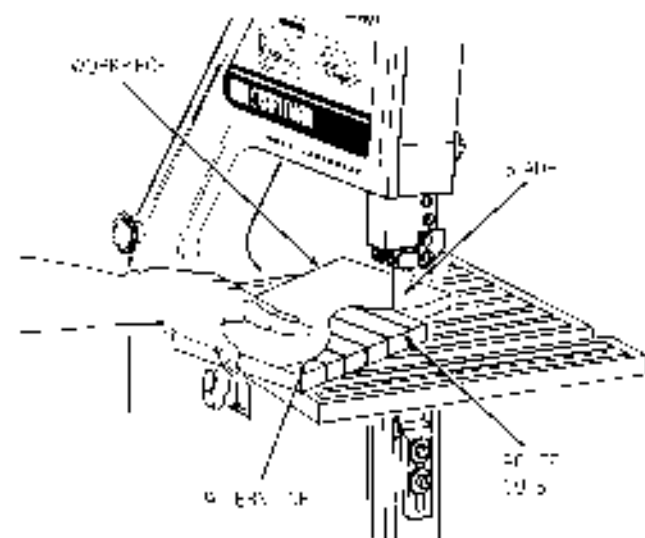

maintenance

WARNING: FOR YOUR OWN SAFETY, TURN SWITCH "OFF" AND REMOVE PLUG FROM POWER OUTLET BEFORE MAINTAINING OR LUBRICATING YOUR BAND SAW.

TIRES

Pitch and sawdust that accumulate on the tires should be removed with a stiff brush or scraped off with a piece of wood. Do not use a sharp knife or any kind of solvent.

When the tires become worn they should be replaced. When replacing the tires, put a thin layer of rubber cement on the outside of the wheels and inside of the tires. Allow to dry, then slide tires onto wheels aligning tires inside wheel edges.

GENERAL

Keep your Band Saw clean.

Remove sawdust from the inside frequently.

Do not allow pitch to accumulate on the table, blade insert, blade guides, or thrust bearings. Clean them with Craftsman Gum and Fit:in Remover.

Apply a thin coat of automobile-type wax to the table so the wood slides easily while cutting. Also apply wax to the inside surfaces of the trunnion.

MOTOR/ELECTRICAL

Frequently vacuum or blow out any sawdust from the motor.

If the power cord is worn, cut, or damaged in any way, have it replaced immediately.

LUBRICATION

All of the BALL BEARINGS are permanently lubricated. They require no further lubrication.

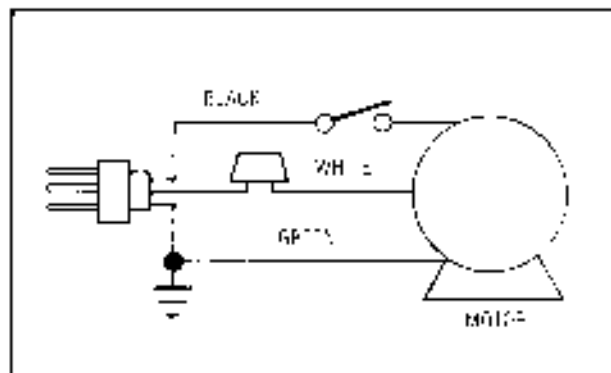

RECOMMENDED ACCESSORIES

Item	Cat. No.
Miter Gauge.....	9-24214
Blades (56-7/8" length).....	See Catalog
Log Set.....	922244

The above recommended accessories are current and were available at the time this manual was printed.

troubleshooting

WARNING: FOR YOUR OWN SAFETY, TURN SWITCH "OFF" AND REMOVE PLUG FROM POWER OUTLET BEFORE READJUSTING OR ALIGNING YOUR BAND SAW.

TROUBLE	PROBABLE CAUSE	REMEDY
Motor will not run.	<ul style="list-style-type: none"> 1. Defective On-Off switch. 2. Defective power or motor cord. 3. Motor Defective. 	<ul style="list-style-type: none"> 1. Replace defective parts before using Band Saw again. 2. Consult Sears Service. Any attempt to repair this motor may create a HAZARD unless repair is done by a qualified service technician. Repair service is available at your nearest Sears Store.
Blade does not run in the approximate center of the upper wheel.	<ul style="list-style-type: none"> 1. Not tracking properly. 	<ul style="list-style-type: none"> 1. Adjust tracking. See Assembly Section, "Tracking the Blade."
Band Saw slows down when cutting.	<ul style="list-style-type: none"> 1. Cutting too small a radius. 2. Dull blade. 	<ul style="list-style-type: none"> 1. Stop feeding, and back up the material slightly, until the band saw speeds up. 2. Replace blade.
Blades breaking.	<ul style="list-style-type: none"> 1. Too much tension. 2. Kink in blade caused by cutting too small a radius or turning the material too fast when cutting. 	<ul style="list-style-type: none"> 1. Adjust tension. See Assembly section "Tensioning The Blade." 2. Use correct cutting technique. See Basic Band Saw Operation Section.
Motor sounds under load when not cutting.	<ul style="list-style-type: none"> 1. Too much blade tension. 2. Too much belt tension. 	<ul style="list-style-type: none"> 1. Adjust blade tension. See Assembly section "Tensioning The Blade." 2. Adjust belt tension. See Assembly Section "Drive Belt Tension."
Blade will not allow for general straight cutting.	<ul style="list-style-type: none"> 1. Blade guides and bearings not properly adjusted. 2. Defective blade. 	<ul style="list-style-type: none"> 1. Adjust upper and lower blade guides and bearings. See Assembly section "Adjusting Upper Blade Guide Assembly." 2. Replace blade.

repair parts

PARTS LIST FOR CRAFTSMAN 10 INCH MOTORIZED BANDSAW MODEL NO. 113.244513

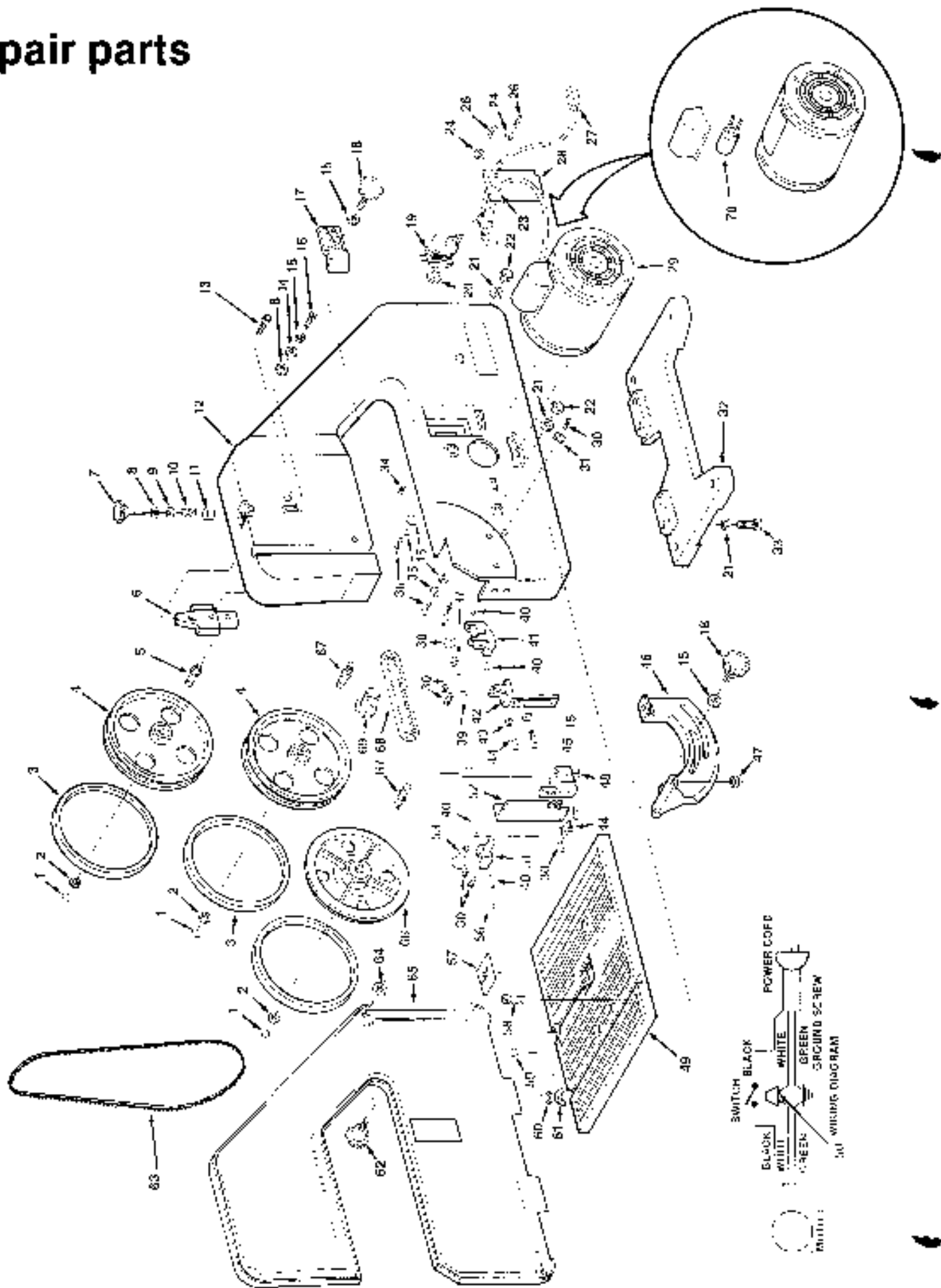

**PARTS LIST FOR CRAFTSMAN 10-INCH MOTORIZED BANDSAW
MODEL NO. 113.244513**

ALWAYS ORDER BY PART NO. AND DESCRIPTION—NOT BY KEY NO.

Key No.	Part No.	Description
1	69166	Ring Holder-Bracket
2	81431*	Washer-Plastic
3	69177	Ice
4	815813	Washer-Blot
5	815273	Shaft-Upper Wheel
6	815286	Guide Wheel
7	813930-4	Knob
8	805352 16	Washer 17/64 x 1 x 1/16
9	817131	Cup-Relaxer*
10	815276	Spring
11	817132	Spacer-Tension
12	815279	Frame
13	STD5C2303	*Screw Set Hex Cup 1/4-20 x 3/8
14	815478	Washer-Spring
15	STD551025	*Washer 17/64 x 47/64 x 1/16
16	STD512510	Screw-Pan HD, 1/4-20 x 1"
17	69146	Clamp Guide Rod
18	69157	Knob
19	62452	Switch Locking
20	60256	Switch-Key
21	S 106613*	*Lockwasher-5/16
22	STD541031	*Nut Hex 5/16 18
23	69164	Relief Strain
24	STD551208	*Lockwasher-Ext. #8
26	STD510802	*Screw-Pan HD, 6-32 x 5/16
27	69147	Cord-Power
28	69149	Cover-Switch
28	69161	*Motor (Includes Key #75)
30	STD511603	*Screw-Pan Cross 10-24 x 3/8
31	69156	Indicator-Soyel
32	815275	Foot-Frame
33	STD523115	*Screw-Hex HD, 5/16-18 x 1 1/2
34	STD513503	*Screw Pan HD, 6-32 x 3/8
35	STD551195	*Lockwasher-1/4
36	69152	Screw-Sec. Cap 1/4-20 x 1

Key No.	Part No.	Description
37	89127	Spacer
38	STD520	Bearing-Ball
39	81389	Shaft-Guide Support
40	69153	Guide
41	813741	Support-Lower Guide
42	69159	Support Guide
43	STD551010	*Washer 13/64 x 1/2 x 3/64
44	STD511815	*Screw-Pan Cross 10-24 x 1/2
45	STD512507	*Screw Pan Cross 1/4-20 x 3/4
45	69178	Turnion
47	STD541025	*Nut Hex 1/4 20
48	69167	Rod-Guide Support
49	69176	Table-Band Saw
50	803709	Corner-Frame
51	69173	Support-Upper Guide
52	69152	Guard-Blade
53	817961	Shaft Axle Bearing
56	60531	Screw-Locking Set 1/4-20 x 5/8
57	69156	Insert Blade
58	80532	Screw-Flat Cross 1/4 x 20 x 1
59	60530	Screw-Tuss HD, 1/4-20 x 3/4
60	34-4923	Washer 7/16 x 5/8 x 1/16
61	STD541625	*Nut-Wing 1/4-20
62	69160	Knob
63	69145	Table-Rand Saw .58 7/32" Long)
64	60532	Ring-Relaxing
65	69148	Cover-Frame
66	815814	Wheel-Drive
67	69168	Shaft-Wheel
68	69124	Roller-Idling
69	69152	Pulley-Turning Belt
70	68075	Capacitor
-	SP5100	Owner's Manual (Not illus.)
-	69189	Bag of Loose Parts (Not illus.)

*Any attempt to repair this motor may create a hazard unless repair is done by a qualified service technician.

Repair service is available at your nearest Sears Store.

*Standard Hardware Items—May Be Purchased Locally

SEARS

owners manual

SERVICE

MODEL NO. 113.244513

HOW TO ORDER REPAIR PARTS

10-INCH BAND SAW

Now that you have purchased your 10-Inch Band Saw should a need ever exist for repair parts or service, simply contact any Sears Service Center and most Sears, Roebuck and Co. stores. Be sure to provide all pertinent facts when you call or visit.

The model number of your 10-Inch Band Saw will be found on a plate at the right-hand side of the saw.

WHEN ORDERING REPAIR PARTS, ALWAYS GIVE THE FOLLOWING INFORMATION:

PART NUMBER	PART DESCRIPTION
MODEL NUMBER 113.244513	NAME OF ITEM 10-Inch Band Saw

All parts listed may be ordered from any Sears Service Center and most Sears stores. If the parts you need are not stocked locally, your order will be electronically transmitted to a Sears Repair Parts Distribution Center for handling.

Sold by SEARS, ROEBUCK AND CO., Chicago, IL. 60684 U.S.A.