

Sears

*owners
manual*

**MODEL NO.
113.243401**

SAW ONLY

**MODEL NO.
113.243411**

SAW WITH LEGS
AND MOTOR

Serial
Number _____

Model and serial
number may be found
at the right-hand side
of the frame.

You should record both
model and serial number
in a safe place for
future use.

CAUTION:

Read **GENERAL** and
ADDITIONAL SAFETY
INSTRUCTIONS
carefully

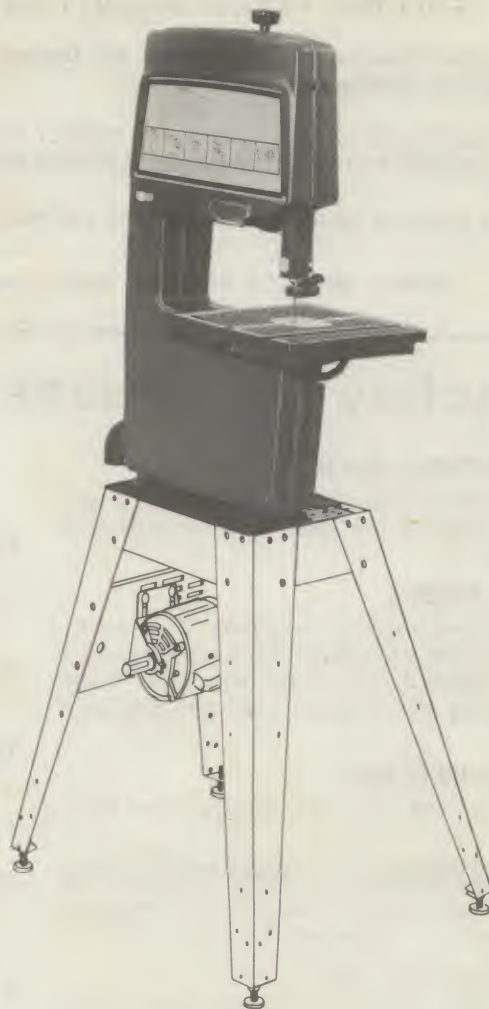

Sears

CRAFTSMAN®

12-INCH BAND SAW/ SANDER

- *assembly*
- *operating*
- *repair parts*

Sold by SEARS, ROEBUCK AND CO., Chicago, IL. 60684 U.S.A.

FULL ONE YEAR WARRANTY ON CRAFTSMAN BAND SAW

If within one year from the date of purchase, this Craftsman Band Saw fails due to a defect in material or workmanship, Sears will repair it, free of charge.

WARRANTY SERVICE IS AVAILABLE BY SIMPLY CONTACTING THE NEAREST SEARS STORE OR SERVICE CENTER THROUGHOUT THE UNITED STATES.

This warranty gives you specific legal rights, and you may also have other rights which vary from state to state.

SEARS, ROEBUCK AND CO., Sears Tower, BSC 41-3, Chicago, IL 60684

general safety instructions for power tools

1. KNOW YOUR POWER TOOL

Read the owner's manual carefully. Learn its application and limitations as well as the specific potential hazards peculiar to this tool.

2. GROUND ALL TOOLS

This tool is equipped with an approved 3-conductor cord and a 3-prong grounding type plug to fit the proper grounding type receptacle. The green conductor in the cord is the grounding wire. Never connect the green wire to a live terminal.

3. KEEP GUARDS IN PLACE

— in working order, and in proper adjustment and alignment.

4. REMOVE ADJUSTING KEYS AND WRENCHES

Form habit of checking to see that keys and adjusting wrenches are removed from tool before turning it on.

5. KEEP WORK AREA CLEAN

Cluttered areas and benches invite accidents. Floor must not be slippery due to wax or sawdust.

6. AVOID DANGEROUS ENVIRONMENT

Don't use power tools in damp or wet locations or expose them to rain. Keep work area well lighted. Provide adequate surrounding work space.

7. KEEP CHILDREN AWAY

All visitors should be kept a safe distance from work area.

8. MAKE WORKSHOP KID-PROOF

— with padlocks, master switches, or by removing starter keys.

9. DON'T FORCE TOOL

It will do the job better and safer at the rate for which it was designed.

10. USE RIGHT TOOL

Don't force tool or attachment to do a job it was not designed for.

11. WEAR PROPER APPAREL

Do not wear loose clothing, gloves, neckties or jewelry (rings, wristwatches) to get caught in moving parts. NONSLIP footwear is recommended. Wear protective hair covering to contain long hair. Roll long sleeves above the elbow.

12. USE SAFETY GOGGLES (Head Protection)

Wear safety goggles (must comply with ANSI Z87.1) at all times. "Everyday eyeglasses only have impact resistant lenses, they are NOT safety glasses." Also, use face or dust

mask if cutting operation is dusty, and ear protectors (plugs or muffs) during extended periods of operation.

13. SECURE WORK

Use clamps or a vise to hold work when practical. It's safer than using your hand, frees both hands to operate tool.

14. DON'T OVERREACH

Keep proper footing and balance at all times.

15. MAINTAIN TOOLS WITH CARE

Keep tools sharp and clean for best and safest performance. Follow instructions for lubricating and changing accessories.

16. DISCONNECT TOOLS

before servicing; when changing accessories such as blades, bits, cutters, etc.

17. AVOID ACCIDENTAL STARTING

Make sure switch is in "OFF" position before plugging in.

18. USE RECOMMENDED ACCESSORIES

Consult the owner's manual for recommended accessories. Follow the instructions that accompany the accessories. The use of improper accessories may cause hazards.

19. NEVER STAND ON TOOL

Serious injury could occur if the tool is tipped or if the cutting tool is accidentally contacted.

Do not store materials above or near the tool such that it is necessary to stand on the tool to reach them.

20. CHECK DAMAGED PARTS

Before further use of the tool, a guard or other part that is damaged should be carefully checked to ensure that it will operate properly and perform its intended function. Check for alignment of moving parts, binding of moving parts, breakage of parts, mounting, and any other conditions that may affect its operation. A guard or other part that is damaged should be properly repaired or replaced.

21. DIRECTION OF FEED

Feed work into a blade or cutter against the direction of rotation of the blade or cutter only.

22. NEVER LEAVE TOOL RUNNING UNATTENDED

Turn power off. Don't leave tool until it comes to a complete stop.

additional safety instructions for band saw/sander

Safety is a combination of operator common sense and alertness at all times when the band saw is being used.

WARNING: FOR YOUR OWN SAFETY, DO NOT ATTEMPT TO OPERATE YOUR BAND SAW UNTIL IT IS COMPLETELY ASSEMBLED AND INSTALLED ACCORDING TO THE INSTRUCTIONS . . . AND UNTIL YOU HAVE READ AND UNDERSTOOD THE FOLLOWING:

	PAGE
1. General Safety Instructions for Power Tools	2
2. Getting To Know Your Band Saw/Sander	18
3. Basic Band Saw Operation	21
4. Maintenance	22
5. Stability of Machine	

Your band saw must be bolted securely to a stand or work bench. In addition, if there is any tendency for the band saw to tip over or move during certain operations such as cutting long heavy boards, bolt your bandsaw to the floor.

6. Location

The band saw should be positioned so neither the operator nor a casual observer is forced to stand in line with the blade. This band saw is intended for indoor use only.

7. Protection: Eyes, Hands, Face, Ears, Body

- a. Wear safety goggles that comply with ANSI Z87.1 and a face shield if operation is dusty. Wear ear plugs or muffs during extended periods of operation. Do not wear gloves . . . roll long sleeves above the elbow.
- b. Do not cut pieces of material too small to hold by hand.
- c. Avoid awkward hand positions where a sudden slip could cause a hand to move into the blade or the sanding belt.
- d. Never turn your band saw "ON" before clearing the table of all Objects (tools, scraps of wood, etc.) except for the workpiece and related feed or support devices for the operation planned.
- e. Make sure the blade runs downward toward the table in the right direction. Always adjust tracking wheel correctly so that the blade does not run off the wheels.
- f. Always adjust tension correctly for the blade or sanding belt being used . . .
- g. Always adjust the upper blade guide and blade guard to just clear the workpiece to protect the operator,

to keep blade breakage to a minimum, and to provide maximum support for blade.

- h. When cutting a large piece of material, make sure it is supported at table height.
 - i. Hold the work firmly against the table.
 - j. Do not feed the material too fast while cutting. Only feed the material fast enough so that the blade will cut. Keep fingers away from the blade.
 - k. Use caution when cutting off material which is irregular in cross section which could pinch the blade before the cut is completed. A piece of molding for example should lay flat on the table and not be permitted to rock while being cut.
 - l. Use caution when cutting off round material such as dowel rods, or tubing. They have a tendency to roll while being cut causing the blade to "bite". Always use a "V" block, or clamp round material to a miter gauge.
 - m. When backing up the workpiece, the blade may bind in the kerf (cut) . . . this is usually caused by sawdust clogging up the kerf. If this happens:
 1. Turn off the band saw . . . remove plug from power source outlet . . . remove cover from band saw. Insert a screwdriver or wedge in the kerf . . . rotate the wheels by hand while backing up the workpiece.
 - n. Never leave the band saw work area with the power on before the machine has come to a complete stop, or without removing and storing the switch key.
 - o. Never operate the band saw with protective cover on on the unused shaft end of the motor removed.
 - p. Do not perform layout, assembly, or setup work on the table while the cutting tool is rotating.
 - q. Remove plug from power, and turn saw "OFF" before installing or removing an accessory or attachment.
8. Should any part of this band saw be missing, or bend, or fail in any way, or any electrical component fail to perform properly, shut off power switch, and remove power supply cord from power supply. Replace damaged, missing, and/or failed parts before resuming operation.
9. Think Safety.

Safety is a combination of operator common sense and alertness whenever the band saw/sander is in operation.

additional safety instructions for band saw/sander



WARNING: THE 5" BAND SAW PULLEY AND THE 2-1/2" MOTOR PULLEY FURNISHED, WILL RUN THE BLADE AT APPROXIMATELY 900 RPM (OR 2700 FEET PER MINUTE) WHEN USED WITH A 1725 RPM MOTOR. NEVER SUBSTITUTE THESE PULLEYS TO INCREASE THIS SPEED BECAUSE IT COULD BE DANGEROUS.

WARNING: DO NOT ALLOW FAMILIARITY (GAINED FROM FREQUENT USE OF YOUR BAND SAW) TO BECOME COMMONPLACE. ALWAYS REMEMBER THAT A CARELESS FRACTION OF A SECOND IS SUFFICIENT TO INFLICT SEVERE INJURY.

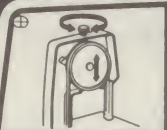
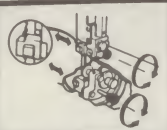
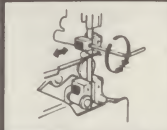
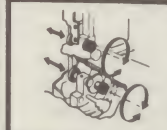

The operation of any power tool can result in foreign objects being thrown into the eyes, which can result in severe eye damage. Always wear safety goggles complying with ANSI Z87.1 (shown on Package) before commencing power tool operation. Safety Goggles are available at Sears retail or catalog stores.

READ AND FOLLOW THE INSTRUCTIONS APPEARING ON THE INSTRUCTION PLATE ON THE FRONT OF THE BAND SAW/SANDER.

					
BLADE TENSION ADJUSTMENT	BLADE GUIDE ALIGNMENT	LATERAL BLADE GUIDE ADJUSTMENT	BLADE THRUST BEARING ADJUSTMENT	ADJUST UPPER GUIDE TO JUST CLEAR WORK	TABLE TILTING

DANGER FOR YOUR OWN SAFETY

READ AND UNDERSTAND OWNER'S MANUAL BEFORE OPERATING THIS MACHINE:

1. ALWAYS WEAR SAFETY GOGGLES PER ANSI Z87.1 AT ALL TIMES WHEN OPERATING THIS MACHINE.
2. BE POSITIVE THE SAW BLADE IS INSTALLED PROPERLY—TEETH POINTING DOWNWARD TOWARD THE TABLE—BEFORE OPERATING MACHINE.
3. BE SURE BLADE TENSION, BLADE GUIDES AND THRUST BEARINGS ARE PROPERLY ADJUSTED BEFORE OPERATING MACHINE.
4. ALWAYS ADJUST UPPER GUIDE SO THAT IT JUST CLEARS WORKPIECE.
5. MINIMIZE INJURY POTENTIAL OF CONTACT WITH SAW BLADE OR SANDING BELT BY KEEPING FINGERS A SAFE DISTANCE AWAY.
6. MAINTAIN CONTROL OF THE WORKPIECE AT ALL TIMES—HOLD FIRMLY AGAINST THE TABLE.
7. BE ATTENTIVE TO THIN CUT-OFF PIECES HITTING END OF SLOT IN INSERT, OR JAMMING IN SLOT. ALLOW BLADE TO STOP BEFORE REMOVING JAMMED PIECE.

12
INCH **BAND SAW-SANDER**

Sears **CRAFTSMAN**®

UL

motor specifications and electrical requirements

This machine is designed to use a **1725 RPM** motor only. Do not use any motor that runs faster than **1725 RPM**. It is wired for operation on 110-120 volts, 60 Hz., alternating current. (TOOL MUST NOT BE CONVERTED TO OPERATE ON 230 VOLT EVEN THOUGH SOME OF THE RECOMMENDED MOTORS ARE DUAL VOLTAGE. CHANGING TO 230 VOLT WILL NOT CONSERVE ENERGY AND REQUIRES CHANGING THE POWER CORD PLUG AND MOTOR RECEPTACLE.

THESE CRAFTSMAN MOTORS HAVE BEEN FOUND TO BE ACCEPTABLE FOR USE ON THIS TOOL.

HP	RPM	VOLTS	CATALOG NO.
1/2	1725	115	1254
1/2	1725	115	1278
1/2	1725	115	1255
1/2	1725	115	1279
3/4	1725	115	1256

CAUTION: Do not use blower or washing machine motors or any motor with an automatic reset overload protector as their use may be hazardous.

CONNECTING TO POWER SOURCE OUTLET

This machine must be grounded while in use to protect the operator from electric shock.

Plug power cord into a 110-120V properly grounded type outlet protected by a 15-amp. time delay or Circuit-Saver fuse or circuit breaker.

If you are not sure that your outlet is properly grounded, have it check by a qualified electrician.

WARNING: DO NOT PERMIT FINGERS TO TOUCH THE TERMINALS OF PLUGS WHEN INSTALLING OR REMOVING THE PLUG TO OR FROM THE OUTLET.

WARNING: IF NOT PROPERLY GROUNDED THIS POWER TOOL CAN CAUSE AN ELECTRICAL SHOCK PARTICULARLY WHEN USED IN DAMP LOCATIONS CLOSE TO PLUMBING. IF AN ELECTRICAL SHOCK OCCURS THERE IS THE POTENTIAL OF A SECONDARY HAZARD SUCH AS YOUR HANDS CONTACTING THE SAW BLADE.

If power cord is worn or cut, or damaged in any way, have it replaced immediately.

If your unit is for use on less than 150 volts it has a plug that looks like below.

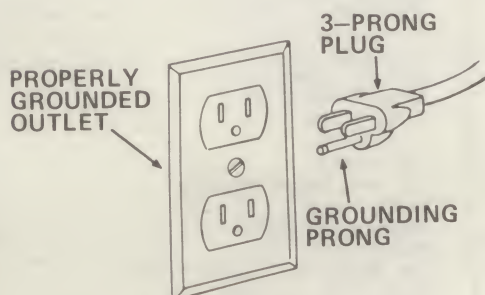

This power tool is equipped with a 3-conductor cord and grounding type plug which has a grounding prong, approved by Underwriters' Laboratories and the Canadian Standards Association. The ground conductor has a green jacket and is attached to the tool housing at one end and to the ground prong in the attachment plug at the other end.

This plug requires a mating 3-conductor grounded type outlet as shown.

If the outlet you are planning to use for this power tool is of the two prong type **DO NOT REMOVE OR ALTER THE GROUNDING PRONG IN ANY MANNER.** Use an adapter as shown below and always connect the grounding lug to known ground.

It is recommended that you have a qualified electrician replace the TWO prong outlet with a properly grounded THREE prong outlet.

An adapter as shown below is available for connecting plugs to 2-prong receptacles. The green grounding lug extending from the adapter must be connected to a permanent ground such as to a properly grounded outlet box.

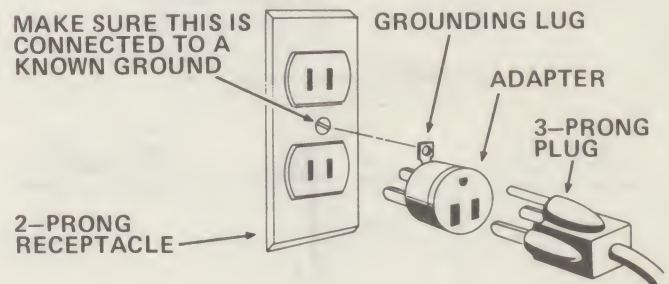

NOTE: The adapter illustrated is for use only if you already have a properly grounded 2-prong receptacle. Adapter is not allowed in Canada by the Canadian Electrical Code.

The use of any extension cord will cause some loss of power. To keep this to a minimum and to prevent overheating and motor burn-out, use the table below to determine the minimum wire size (A.W.G.) extension cord. Use only 3 wire extension cords which have 3-prong grounding type plugs and 3-pole receptacles which accept the tools plug.

Extension Cord Length	Wire Size A.W.G.
Up to 100 Ft.	16
100 - 200 Ft.	14
200 - 400 Ft.	10

CHECK MOTOR ROTATION

WARNING: FOR YOUR OWN SAFETY, MAKE SURE PLUG IS NOT CONNECTED TO POWER SOURCE OUTLET. WHEN CHANGING MOTOR ROTATION.

The motor must rotate **COUNTERCLOCKWISE** when viewed from the shaft end to which you will mount the pulley. (See page 10) If it does not, change the direction according to the instructions furnished with the motor.

unpacking and checking contents

CONTENTS

UNPACKING AND CHECKING CONTENTS	6
ASSEMBLY	
Installing Sawdust Elbow	7
Assembling Steel Legs	8
Installing Table	8
Motor Pulley Belt Guard and Motor Installation	9
Check Motor Rotation	10
Mounting Motor	10
Attaching Belt Guards	11
Installing The Blade	12
Adjusting The Table	16
On-Off Switch	16
GETTING TO KNOW YOUR BAND SAW/SANDER	
Adjustment Diagrams	18
Tension Adjustment Knob	18
Tension Scales	18

Table Tilting	18
Blade Guide Adjustment	18
Lateral Guide Adjustment	18
Blade Thrust Bearing Adjustment	18
Guide Bar Lock Screw	18
Guide Bar	19
Installing Sanding Attachment	19
BASIC BAND SAW/SANDER OPERATION	
Sawing	21
Sanding	21
MAINTENANCE	
Tires	22
General	22
Motor	22
Lubrication	22
Recommended Accessories	22
TROUBLE SHOOTING	
REPAIR PARTS	

TOOLS NEEDED

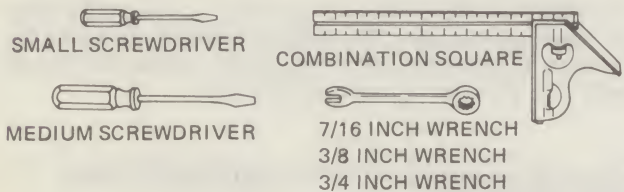

COMBINATION SQUARE MUST BE TRUE

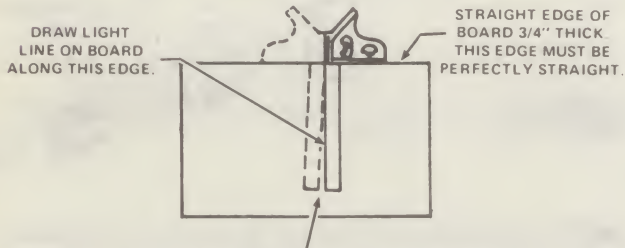

SHOULD BE NO GAP OR OVERLAP HERE WHEN SQUARE IS FLIPPED OVER IN DOTTED POSITION.

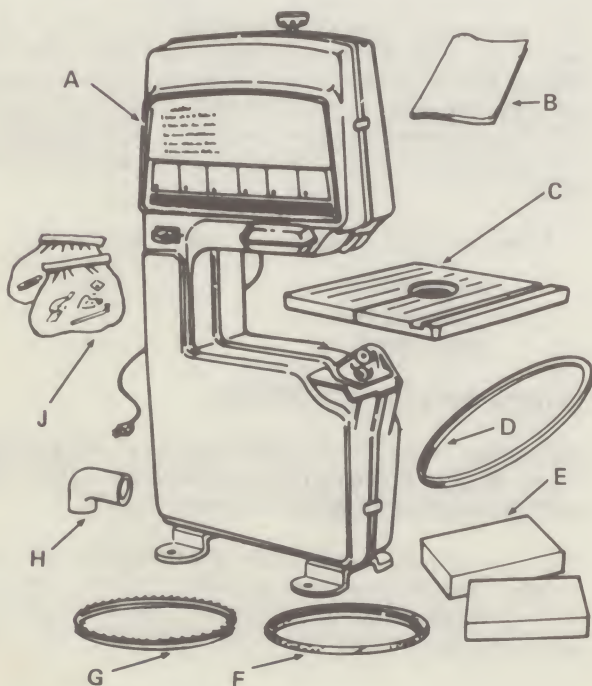

Model 113.243401 Band Saw/Sander is shipped complete in one carton but **DOES NOT INCLUDE** Steel Legs or Motor.

Model 113.243411 Band Saw/Sander is shipped complete in one carton and **INCLUDES** Steel Legs and Motor.

Separate all parts from packing materials and check each item with illustration and "Table of Loose Parts." Make certain all items are accounted for, before discarding any packing material.

If any parts are missing, do not attempt to assemble the band saw, plug in the power cord or turn the switch on until the missing parts are obtained and installed correctly.

ITEM	TABLE OF LOOSE PARTS	QTY.
A	Basic Saw Assembly	1
B	Owner's Manual	1
C	Saw Table	1
D	1/2 x 52-In. V-Belt	1
E	Carton containing Belt Guard, Belt-Guard Support, Support Bracket, three Clips and three Self-Tapping Screws	2
F	1/2-In. Sanding Belt	1
G	1/4-In. Band Saw Blade	1
H	Sawdust Elbow	1
J	Two Bags containing the following items:	
	Set Screw Wrench, 1/8"	1
	Set Screw Wrench, 5/32"	1
	Set Screw Wrench, 3/16"	1
	Flat Washer, 1-1/8" diameter	1
	Trunnion Locknut	1
	Pan Hd. Mach. Screw, Self Tap, 10-32 x 3/8"	2
	Pan Hd. Mach. Screw, Self Tap, 8-32 x 3/8"	2
	Soc. Hd. Setscrew, Flat Pt., 5/16-18 x 3/8"	1
	Flat Hd. Mach. Screw, 6-32 x 7/16"	1
	Hex Nut, 6-32	1
	Split Lockwasher, No. 6	1
	Tilt Pointer	1
	Tube Clamp	1
	Rubber Gasket (strip)	1
	Alignment Plate	1
	Motor Pulley, 2-1/2"	1
	Sanding Platen	1
	Cord Clamp	1
	Table Insert	1
	Tilt Lock Handle (Wrench)	1
	Spacer	1
	Blade Tension Knob	1
	Switch Key	1
	Flat Washer, 9/32 x 5/8 x 1/16	1
	Screw Truss Hd., 1/4-20 x 1	1
	Wing Nut, 1/4-20	1

THE FOLLOWING PARTS ARE INCLUDED WITH MODEL 113.243411 ONLY.

Item	Description	Qty.
A	* Nut, Hex Head 1/2-13	8
A	* Nut Hex 1/4-20	32
B	* Screw Truss Hd. 1/4-20 x 5/8	32
C	* Lockwasher, 1/4 External	32
D	* Foot, Leveling	4
E	Motor	1
F	Leg	4
G	Channel, Support	2
H	Stiffener, Side	2
J	Stiffener, End	2
K	Support, Motor	1
HARDWARE FOR MOUNTING TOOL & MOTOR		
L	* Screw, Hex Hd. 5/16-18 x 1	4
C	* Lockwasher Ext. 5/16	8
A	* Nut, Hex 5/16-18	8
M	* Washer 11/32 ID	8
N	* Bolt, Carriage 5/16-18 x 3/4	4

* Parts Contained In Loose Parts Bag Part No. 69097

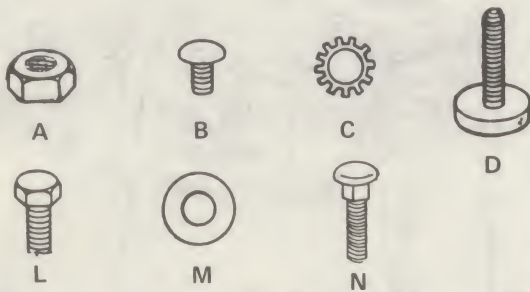
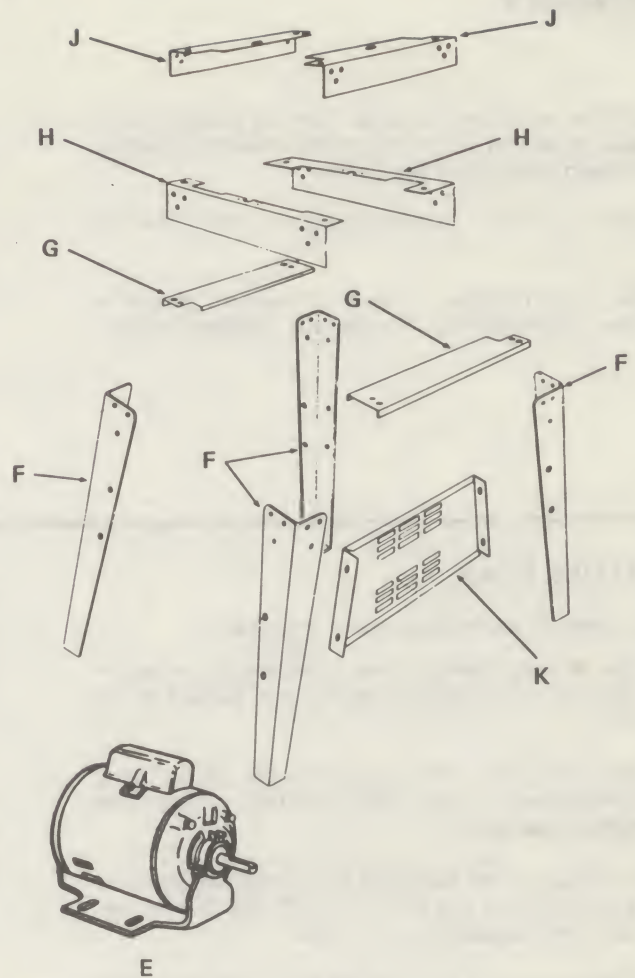

INSTALLING SAWDUST ELBOW

1. Remove the Band Saw cover by applying gentle side pressure on the spring tabs and release the top portion of the cover by pulling it away from the frame. Repeat procedure for bottom portion of cover.
2. Find the sawdust elbow, the clamp, the strip of rubber gasket, and two 10-32 x 3/8" self-threading screws among the loose parts.

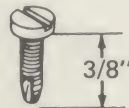

3. Place the elbow in the opening at the bottom left-hand side of saw as shown, and attach the clamp with the two screws.

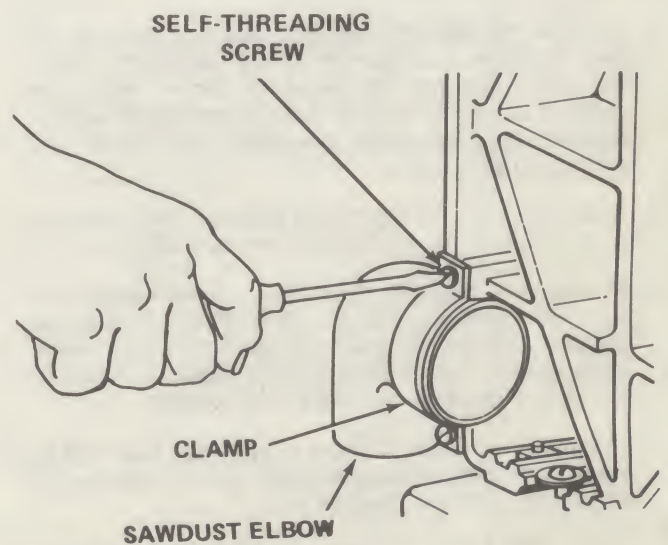

assembly

4. Peel off the protective covering from the rubber gasket and stick it around the clamp. Make sure it extends a little beyond each end of the clamp.

The gasket will help to prevent sawdust from leaking out.

For the most efficient removal of sawdust, attach a Craftsman Home-n-Shop Vac to the sawdust elbow.

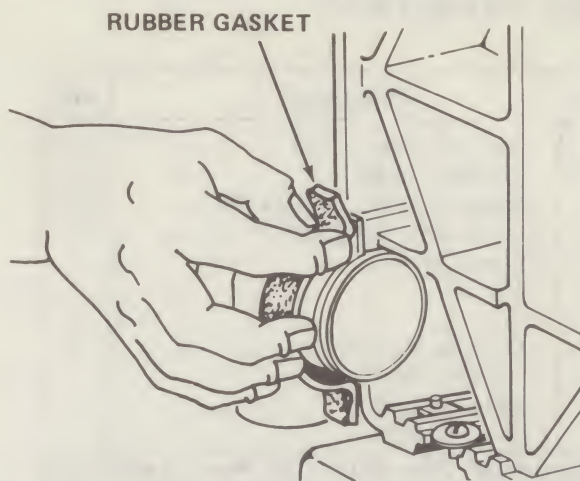

INSTALLING TABLE

Apply a coat of automobile wax to the table.

1. Place the table on the band saw so that the two trunnion pins and the table lock bolt go through the slot in the trunnion.
2. Find the 1-1/8" dia. flat washer, a sleeve 11/16" long, the trunnion lock nut and the table lock handle from among the loose parts.
3. Hold the head of the table lock bolt inside the band saw with your left hand and put the 1-1/8" dia. flat washer, the sleeve, and the handle on the bolt.
4. Screw the nut on the bolt and tighten it with the handle while the table is in a horizontal position.

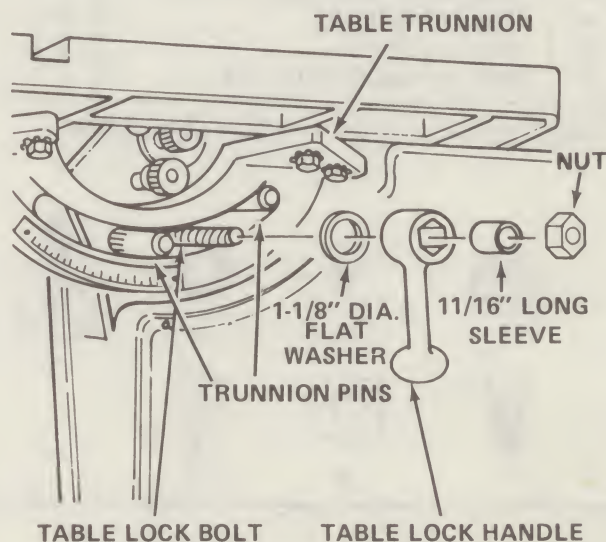

ASSEMBLING STEEL LEGS

1. Assemble the two (2) End Stiffeners and the two (2) Side Stiffeners using four (4) 1/4-20 Truss head screws. The End Stiffeners are placed on top of each Side Stiffener as shown. Insert screws through the 9/32 inch diameter holes and attach lockwashers and 1/4-20 nuts and finger tighten nuts.
2. Attach the four (4) legs to the Side and End Stiffeners using 1/4-20 screws, lockwashers and nuts as shown.
3. Remove the four (4) Truss head screws which were assembled in Paragraph No. One. Place the two (2) Support Channels as shown, in position, align holes in supports with holes in the Stiffeners, replace lockwashers and nuts. Tighten all nuts using 7/16" wrench.
4. Assemble the motor support to steel legs with 1/4-20 screws and nuts. Motor support can be mounted to either end of stand. Tighten nuts.
5. Install leveling feet as shown. To level Leg Set, loosen nut on inside of leg and turn nut on outside to raise or lower feet. Adjust all four levelers, if necessary, and then tighten nuts on inside of leg.

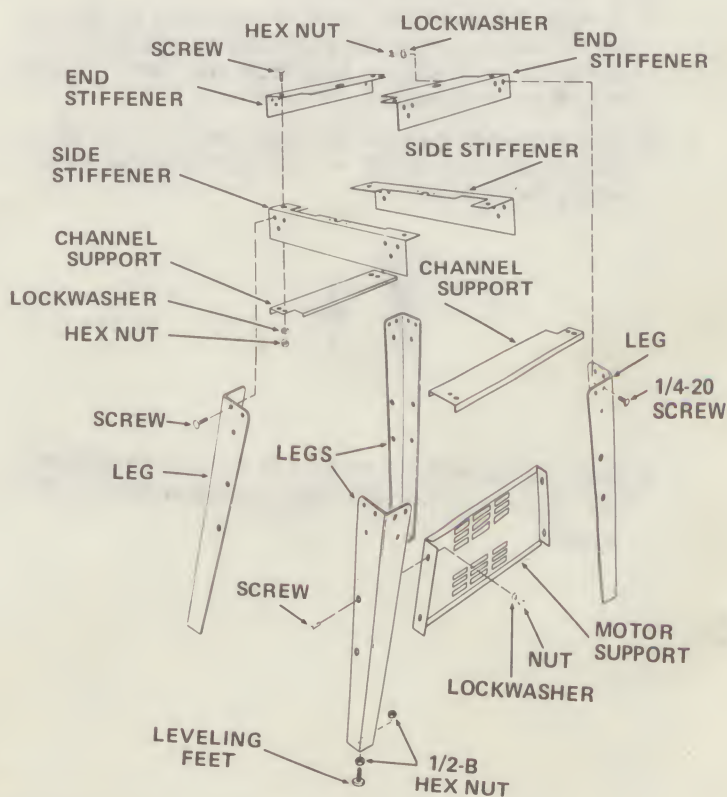

NOTE: These levelers are not intended for height adjustment.

assembly

MOUNTING BAND SAW/SANDER ON FLOOR STAND

NOTE: For illustrative purposes, the Band Saw is shown mounted on the Craftsman Catalog No. 9-22236 Steel Leg Set. This Leg Set is included with Model No. 113.243411.

1. Remove the Band Saw cover by applying gentle side pressure on the spring tabs and release the top portion of the cover by pulling it away from the frame. Repeat procedure for bottom portion of cover.

NOTE: Check the bolts which hold the feet to the Band Saw as shown. Make sure they are tight.

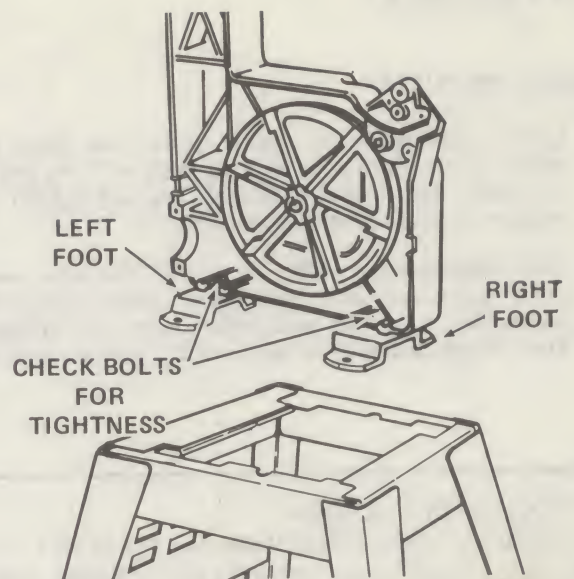

2. Place the Band Saw on the Steel Legs, position as shown, and align the mounting holes in the feet of the Band Saw with those in the END STIFFENERS (marked with an X in the illustration).

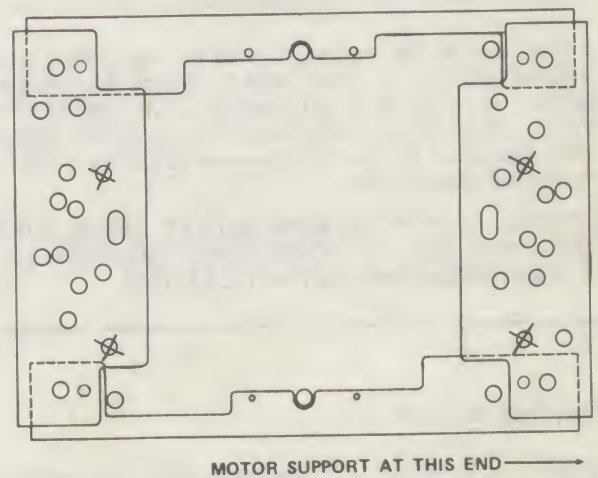

MOTOR PULLEY BELT GUARD AND MOTOR INSTALLATION

MOUNTING BELT GUARD

1. Place the motor on your workbench with the shaft facing you.

If you are using a double shaft motor, the 5/8" dia. shaft must be facing you.

2. Attach guard support to the bracket with the two screws, furnished with the guard.

NOTE: The holes in the bracket are not threaded, but the screws are "thread cutting screws" and will cut a thread as they are tightened.

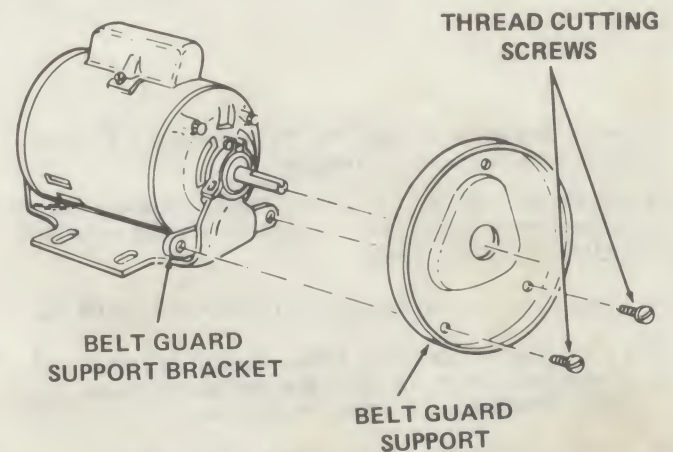

assembly

MOUNTING PULLEY

1. Loosen setscrew in the motor pulley and place the pulley on the shaft with the hub flush with the end of the shaft. Insert the motor shaft key and tighten the setscrew with 5/32" setscrew wrench.

When installing the pulley on a 1/2" diameter motor shaft, make sure that the adapter sleeve and 3/16" square key furnished with your motor are in place. Then tighten the setscrew with a 5/32" setscrew wrench.

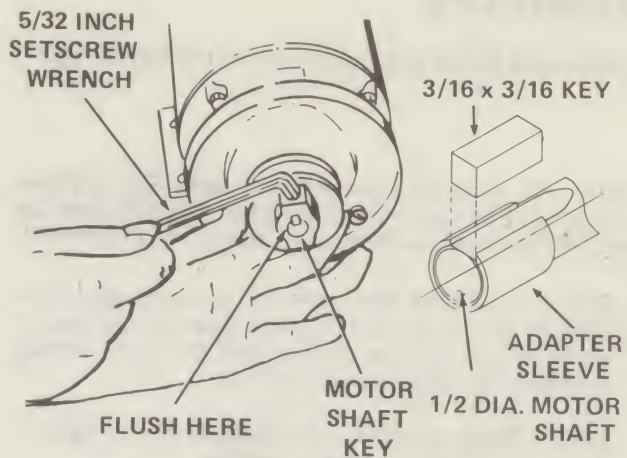

CHECK MOTOR ROTATION

NOTE: Motor supplied with Model No. 113.243411 only. The motor must rotate **COUNTERCLOCKWISE** when viewed from the **PULLEY** end.

1. Place the motor on your workbench or on the floor.
2. Stand clear of the motor and plug the cord into a properly grounded outlet (See page 4). Notice the rotation of the pulley. If it is not turning **COUNTERCLOCKWISE**, **REMOVE** the plug from the outlet, and change the rotation of the motor according to the instructions furnished with the motor.

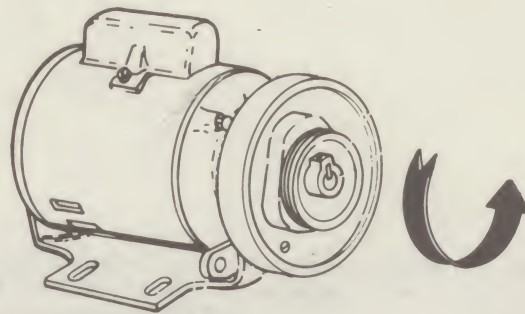

WARNING: FOR YOUR OWN SAFETY, MAKE SURE PLUG IS NOT CONNECTED TO POWER SOURCE OUTLET WHEN CHANGING MOTOR ROTATION.

MOUNTING MOTOR

1. Find four 5/16"-18 x 1" carriage bolts, flat washers, lockwashers and nuts supplied with the base.

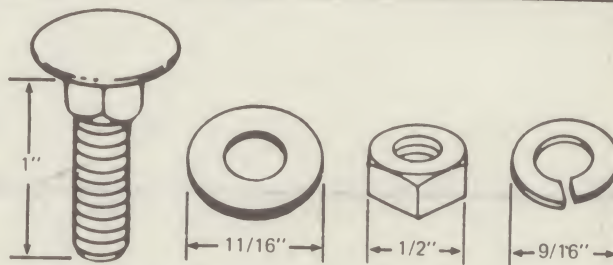

2. Insert the bolts through the holes marked "X" from behind the motor mount bracket.
3. Attach the motor . . . place a flat washer and a lockwasher on each bolt . . . screw on the nuts but **DON'T TIGHTEN** them.
4. Loosen the two **BELT GUARD SUPPORT SCREWS**.
5. Loosen the two **MOTOR BASE CLAMP SCREWS** and rotate the motor so that the ventilation holes are facing downward . . . tighten the screws.
6. Tighten the **BELT GUARD SUPPORT SCREWS**.

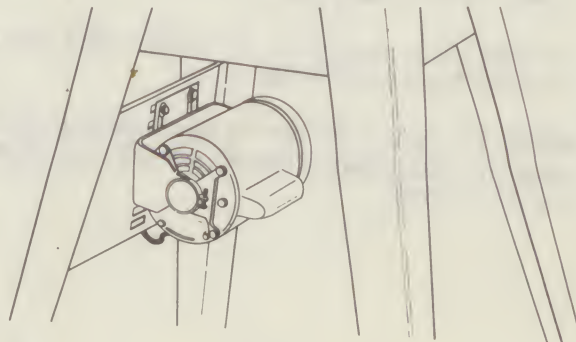
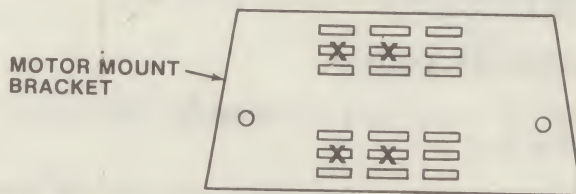

ATTACHING BELT GUARDS

1. Remove the pulley from the band saw, using the 5/32" setscrew wrench to loosen the screw. Be careful not to lose the shaft key.

Attach the belt guard support with the three screws furnished with the guard.

NOTE: The support bracket is not required.

The holes for attaching the support are not threaded, but the screws are "self-threading" and will cut a thread as they are screwed in.

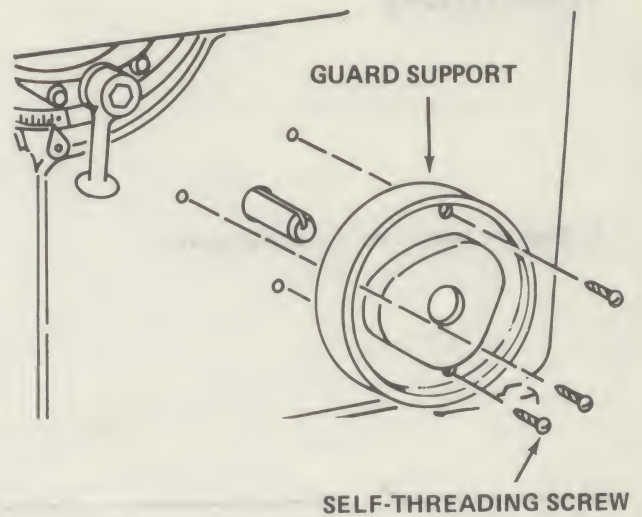

2. Replace the pulley with the hub flush with the end of the shaft.

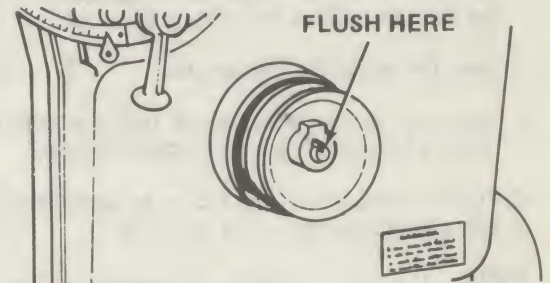

3. Install three clips on the belt guard 90° apart with the long tabs pointing AWAY from the round opening.
4. Insert one looped end of the belt all the way into the guard so that it will be below the motor pulley.

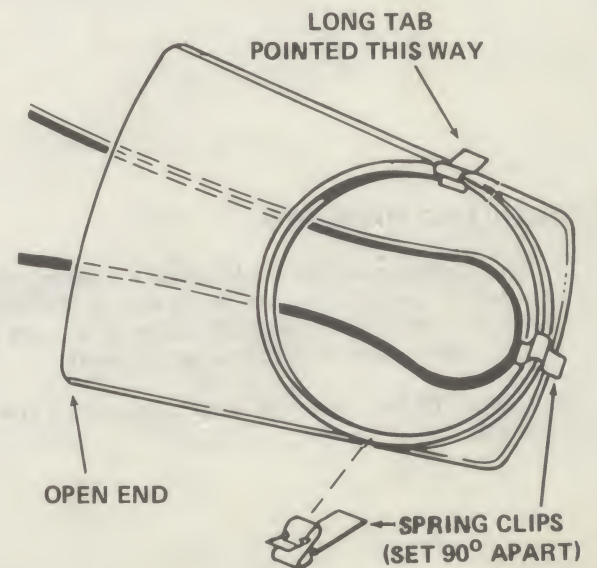

assembly

5. Snap the guard into position as shown.

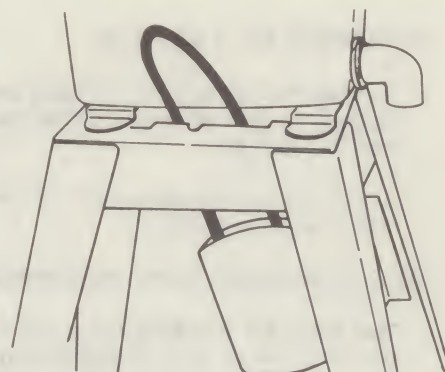

6. Look down into the guard . . . pull the belt upwards onto the motor pulley.
7. Insert the belt into the open end of the second belt guard, and out the round opening. Place the belt onto the band saw pulley by rotating the pulley.
8. Snap the belt guard into position.
9. Move the motor sideways so that the belt is in the center of the opening in the top of the base.
10. PUSH downward on the motor to apply tension to the belt and tighten the motor bolt nuts.

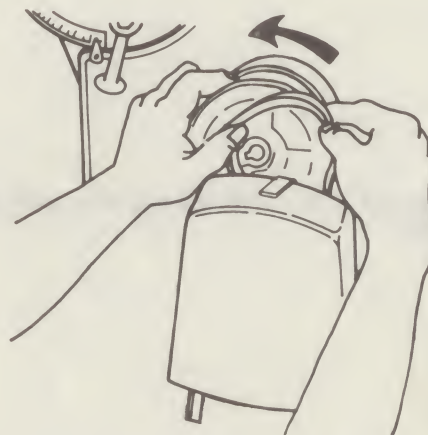

NOTE: It is only necessary to tension the belt so that it does not slip while running.

If you cannot obtain sufficient tension with the motor pushed all the way down, remove the four motor bolts and insert them in the LOWER set of holes.

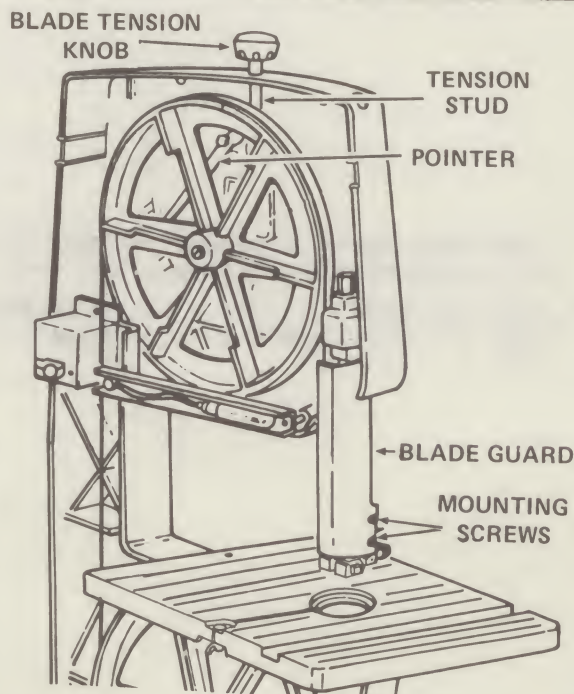

INSTALLING THE BLADE

1. Find the blade tension knob among the loose parts. Put a dab of grease or vaseline on the end of the knob and screw it on the tension stud. Screw it on only a few turns, just enough to start moving the pointer.
2. Loosen the two mounting screws and remove the blade guard.

3. Loosen the guide bar lock screw and position the upper guide assembly approximately three inches above the table as shown and tighten the lock screw.

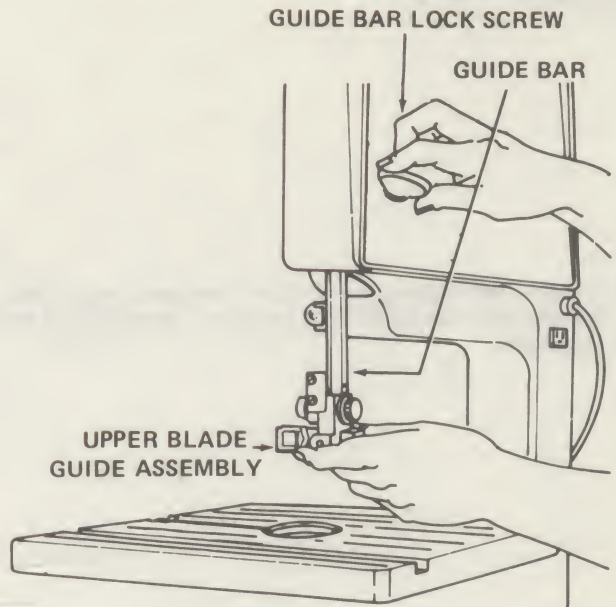

4. Loosen the two setscrews which lock the upper blade guides and separate them about 1/8".

Do that same thing to the lower guides beneath the table. See Page 14 Step 6 for location of setscrew.

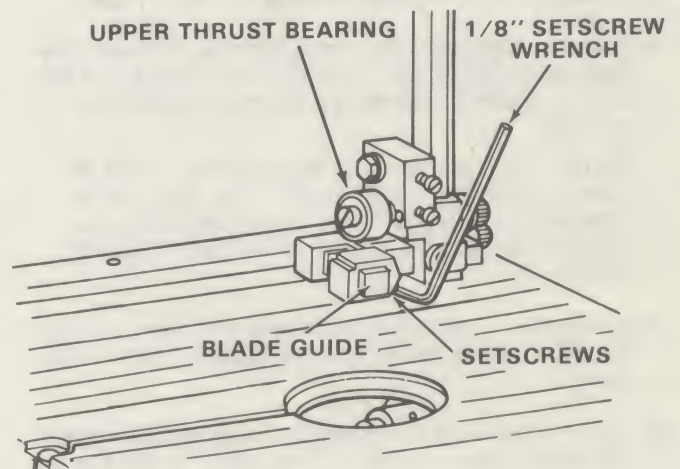

5. Loosen the setscrew which locks the upper thrust bearing and turn the knob until the thrust bearing is all the way back as shown.

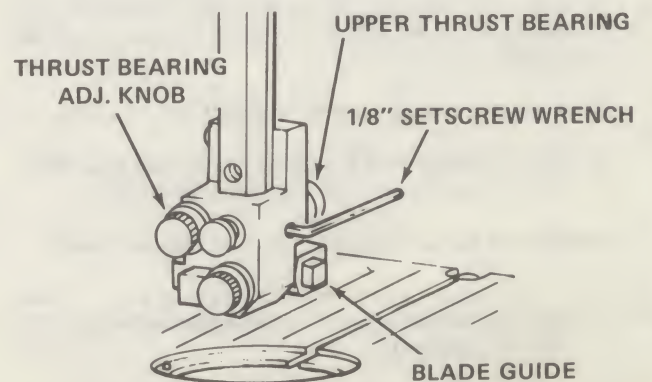

assembly

- Loosen the setscrew which locks the lower thrust bearing and turn the knob until the thrust bearing is all the way back.

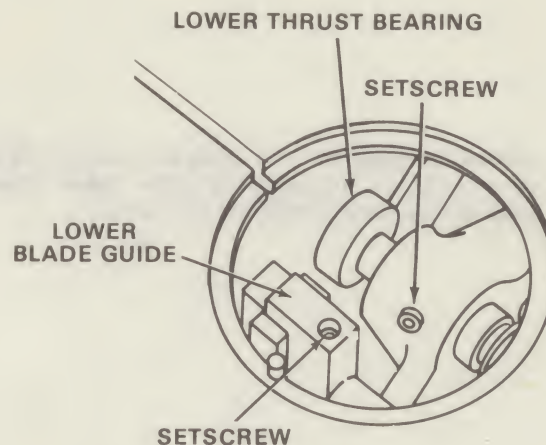

- Carefully uncoil the blade, holding it at arms length.
- Place the blade over the wheels with the teeth pointing downwards toward the table as shown. Make sure the blade is between the blade guides and is in the center of the rubber tires.

NOTE: Your bandsaw can be used with blades of various widths from 1/8" to 1/2". The saw must be adjusted to the proper blade tension setting for the blade to be used. A 1/4" wide blade is included with this saw.

- Screw down the tension knob until the pointer points to 1/4. This will put sufficient tension on a 1/4" wide blade.
- Turn the upper wheel by hand a few times and notice if the blade remains in the approx. center of the tire on the top wheel.

If the blade moves away from the center of the wheel while you are turning it, the blade is not TRACKING properly.

The top wheel shaft is hinged which allows the wheel to be tilted so that the blade can be TRACKED. By turning the tracking adjustment screw, the wheel will be tilted. (see illustration).

If the blade moves toward the front of the band saw:

- Turn the tracking adjustment screw clockwise about 1/4 of a turn, as though you were tightening it.

If the blade moves toward the back of the band saw:

- Turn the tracking adjustment screw counterclockwise about 1/4 of a turn as though you were loosening it.

Turn the screw just enough to cause the blade to run in the approximate center of the tire.

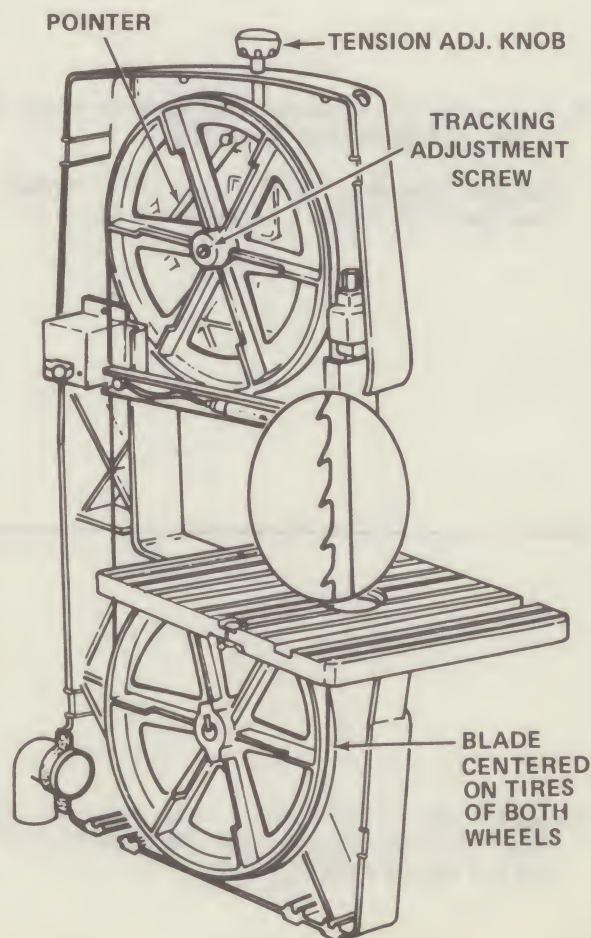

The thrust bearings support the blade from the rear and will rotate when the blade is pushed against them while you are cutting. As soon as you stop cutting, the bearings should stop rotating.

11. To be sure the thrust bearing is properly supporting the blade, turn the thrust bearing adjustment knob so that the bearing moves toward the blade and almost touches it.
12. While turning the upper wheel to the right by hand, adjust the thrust bearing until it barely touches the blade and starts to rotate. Now move the bearing back slightly, until it stops rotating. Tighten the thrust bearing setscrew.
13. Adjust the lower thrust bearing the same way.

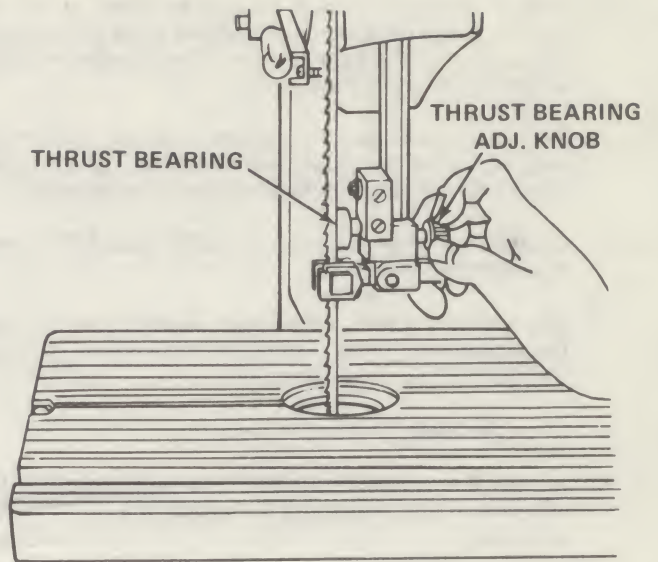

NOTE: The upper and lower blade guides support the blade and keep it from twisting during operation. An adjustment is necessary when blades are changed or replaced.

14. To adjust the upper blade guides loosen the setscrew which locks the blade guide holder (see illustration).
15. Turn the blade guide adjustment knob, so that the guides move toward the blade. Move them until the "ledge" is about 1/32" from the deepest part of the blade teeth. This deep part is called a "gullet". Tighten the setscrew.
16. Adjust the lower guides the same way.

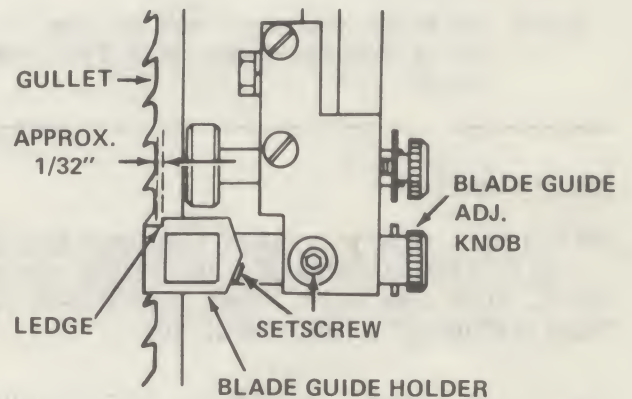

17. Press the two guides evenly against the sides of the blade, but don't pinch the blade. Release the guides and rotate the upper wheel a little bit, moving the blade downward. Make sure one guide is not farther away from the blade than the other. Tighten both setscrews.
18. Adjust the lower guides the same way.
19. Rotate the upper wheel a few times by hand, and check the guides and thrust bearings. Make readjustments if necessary.
20. Replace the blade guard on the upper guide support.
21. Locate the table insert and place it in the opening in the table.
22. Replace the cover.

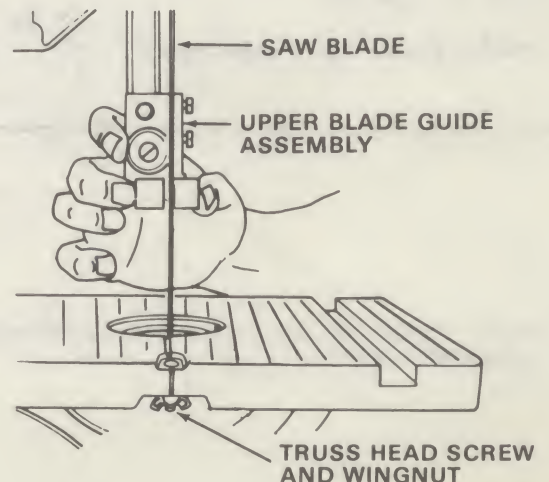

assembly

ADJUSTING THE TABLE

1. Find a 1/4-20 x 1 inch truss head screw, a regular washer, and a 1/4-20 wing nut among loose parts. Insert the screw into the hole in the table top as shown in the illustration at the bottom of page 15.
2. From the underside of the table, screw the washer and wing nut onto the truss head screw and tighten finger tight. This will keep the table flat and in alignment.
3. Locate among the loose parts a 5/16"-18 x 3/8" socket head flat point setscrew.
4. This setscrew acts as a 90° stop. Screw it partially into the tapped hole in the top of the table on the left side. Use the 5/32" setscrew wrench.
5. Raise the blade guides all the way up.
6. Loosen the table lock slightly and push down on the left side of the table until it touches the frame of the band saw.
7. Screw in the stop screw and notice that as it touches the frame, the table will start to tilt.
8. Place a square on the table against the blade and continue to screw in the stop screw until the table is square with the blade. Tighten the table lock.

"NOTE: The combination square must be "true" — see start of "assembly" section on pg. 6 for checking method."

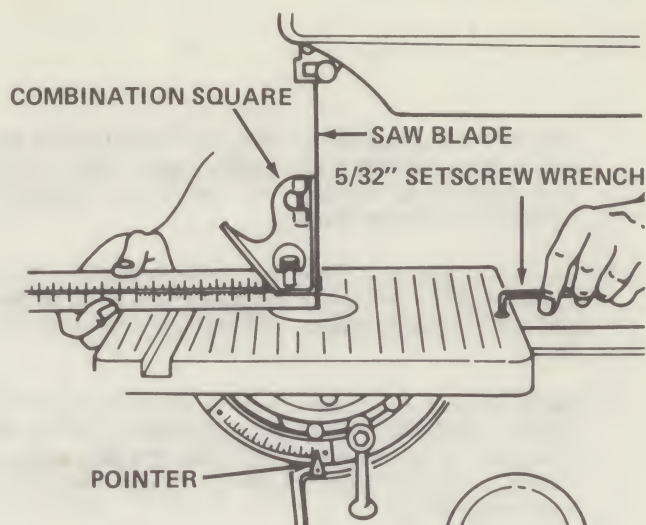

NOTE: If the plastic housing should interfere with the underside of the table so that the table will not level, loosen the 4 bolts that hold the trunnion (see page 8) to the table and slide the table toward the rear of the saw. Tighten the bolts. The table should now adjust to a level position.

9. Find the pointer and a pan head thread cutting screw 8-32 x 3/8 inches long and attach the pointer. Set it at 0 degrees and tighten the screw.

ON-OFF SWITCH

WARNING: DON'T CONNECT POWER CORD TO ELECTRICAL OUTLET IN YOUR SHOP UNTIL YOU ARE SURE THAT MOTOR ROTATION IS CORRECT. (SEE PAGE 10).

The On-Off Switch has a locking feature. THIS FEATURE IS INTENDED TO PREVENT UNAUTHORIZED AND POSSIBLY HAZARDOUS USE BY CHILDREN AND OTHERS.

1. Insert key into switch.

NOTE: Key is made of yellow plastic

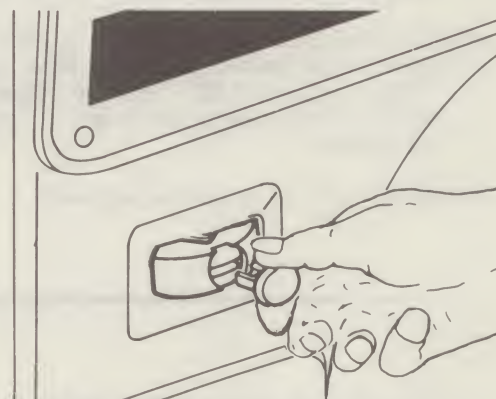

2. To turn machine on, insert finger under switch lever and pull end of switch out.

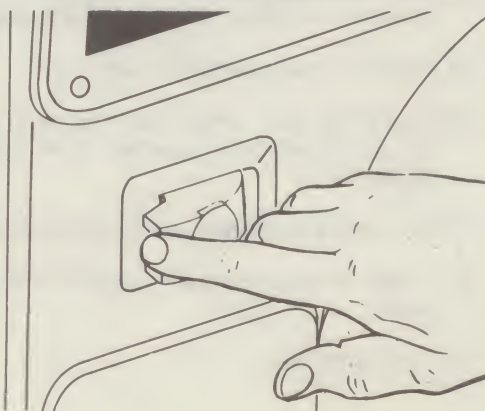

3. To turn machine OFF . . . PUSH lever in.

Never leave the machine unattended until it has come to a complete stop.

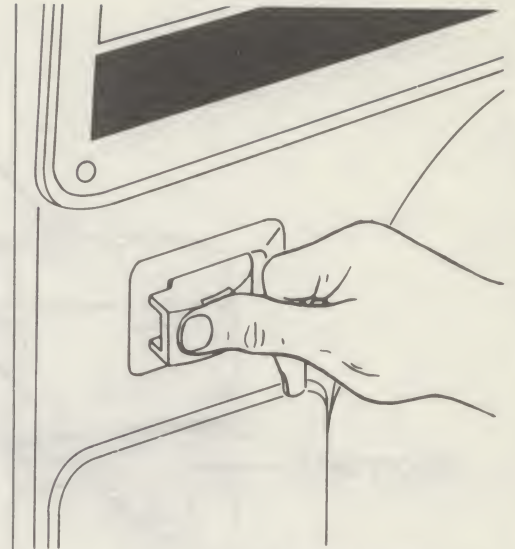

4. To lock switch in OFF position . . . hold switch IN with one hand . . . REMOVE key with other hand.

WARNING: FOR YOUR OWN SAFETY, ALWAYS LOCK THE SWITCH "OFF" WHEN MACHINE IS NOT IN USE . . . REMOVE KEY AND KEEP IT IN A SAFE PLACE . . . ALSO . . . IN THE EVENT OF A POWER FAILURE (ALL OF YOUR LIGHTS GO OUT) TURN SWITCH OFF . . . LOCK IT AND REMOVE THE KEY. THIS WILL PREVENT THE MACHINE FROM STARTING UP AGAIN WHEN THE POWER COMES BACK ON.

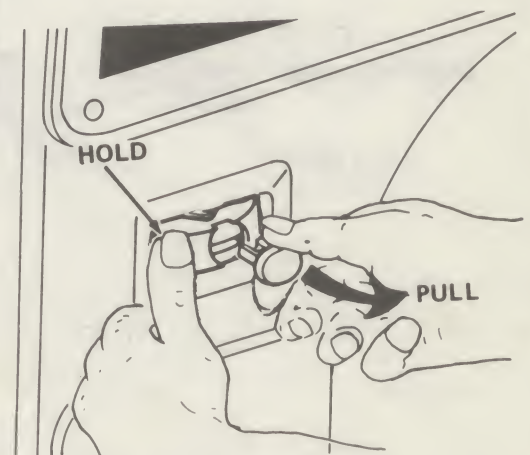

INSTALLING MOTOR CORD CLAMP

1. Find the cord clamp and one 8-32 x 3/8 pan hd. self threading screw and install below the motor-cord outlet as shown.

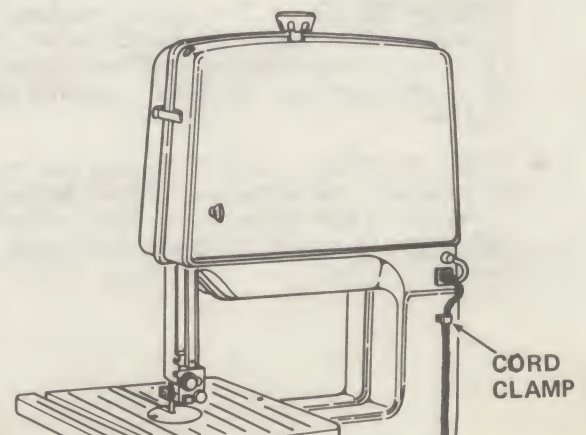

getting to know your band saw/sander

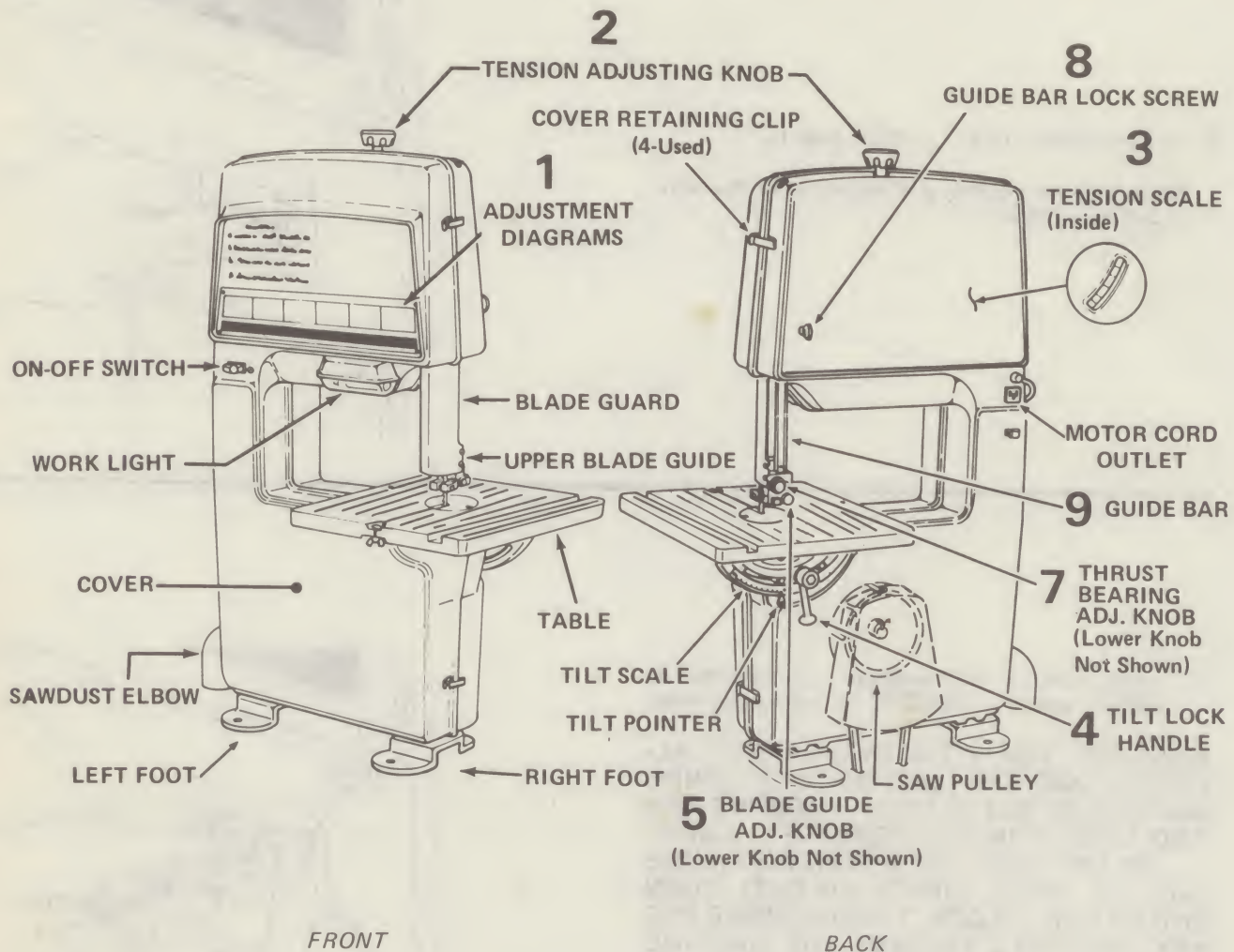

1. **ADJUSTMENT DIAGRAMS** . . . Help you to become familiar with the adjustments.
2. **TENSION ADJUSTMENT KNOB** . . . Tightening the knob will increase the tension on the blade. Loosening it will decrease the tension.
3. **TENSION SCALES** . . . The fractional markings indicate the correct blade tension for various widths of blades. For example, when installing a 1/4" wide blade, tighten the tension knob until the pointer is pointing to the 1/4 marking.
4. **TABLE TILTING** . . . Loosen the table lock handle, tilt the table to the desired angle and tighten the lock handle. To return the table to the 90° position, tilt it until the 90° stop screw rests on the frame, then tighten the lock handle.

5. **BLADE GUIDE ADJUSTMENT** . . . Turning the knob moves the guides in or out for various widths of blades.
6. **LATERAL BLADE GUIDE ADJUSTMENT** . . . The guides can be adjusted sideways and locked in position by the setscrews.
7. **BLADE THRUST BEARING ADJUSTMENT** . . . Turning the knob moves the thrust bearings in or out for various widths of blades.
8. **GUIDE BAR LOCK SCREW** . . . The upper blade guides should just clear the workpiece while cutting. Always adjust the guides before turning on the band saw and lock the guide bar by tightening the thumb screw.

9. GUIDE BAR

When the upper guides are raised or lowered, they must not deflect the blade sideways. This means that the guide bar must be parallel to the blade, or square with the table.

1. Remove the blade guard, cover, blade, and the upper guide assembly.
2. Lower the guide bar until the end is approximately 1-3/4" from the table.
3. Hold a square on the table against the guide bar.
4. If the bar is not square with the table, lock the guide bar and loosen the four screws in the guide bar support with a 3/16" setscrew wrench. To reach the lower left screw, it will be necessary to tilt the upper wheel outward.

NOTE: The holes in the guide bar support are larger than the screws. This allows the support to be moved.

5. Move the guide bar until it is square with the table, then tighten the screws.
6. Be sure to replace the blade guard before operation.

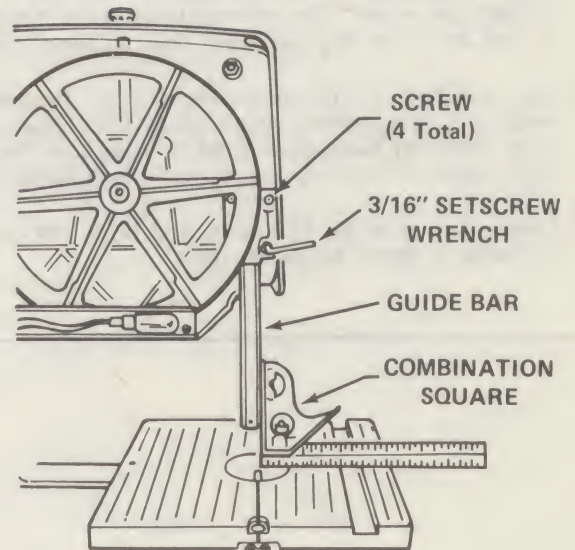

INSTALLING SANDING ATTACHMENT

WARNING: FOR YOUR OWN SAFETY, TURN SWITCH "OFF" AND ALWAYS REMOVE PLUG FROM POWER SOURCE OUTLET BEFORE INSTALLING SANDING ATTACHMENT.

1. Remove the blade guard, the table insert, and the table alignment screw.
2. Remove the cover, release the blade tension and remove the blade.
3. Remove the upper blade guide assembly. Use a 7/16" wrench to remove the screw.
4. Loosen the setscrew that locks the lower thrust bearing, and move the bearing as far back as it will go.
5. Loosen the two setscrews that lock the lower blade guides. Spread them apart so that the end of each guide is inside the holder.

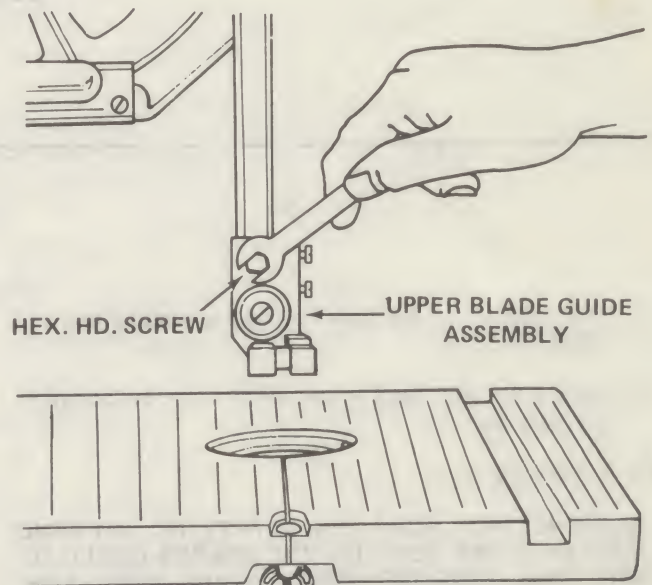

getting to know your band saw/sander

6. Attach the sanding platen to the guide bar with the same screw that held the upper blade guide assembly. Do not tighten the screw at this time.

On the smooth side of the sanding belt, you will find a "directional arrow". The belt must run in the direction of this arrow so that the splice does not come apart.

7. Place the belt on the wheels and tighten the tension knob until the pointer points to SAND. Rotate the upper wheel by hand a few times to make sure that the belt is tracking properly and is not rubbing the guides.
8. Loosen the guide bar lock screw and lower the end of the sanding platen below the table.

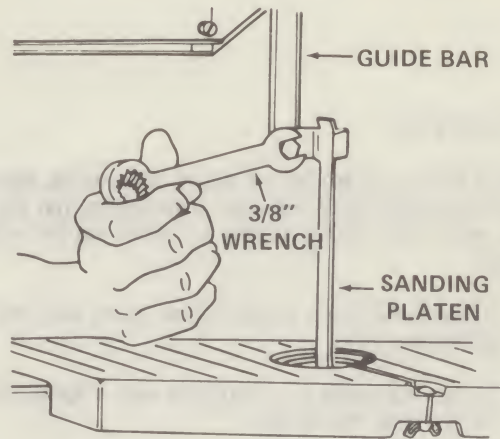

9. Locate among the loose parts, the alignment plate, a flat head machine screw 6-32 x 7/16", a small hex nut and lockwasher.

10. Attach the alignment plate to the insert so that the end of the alignment plate is in the center of the slot in the insert. Place the insert in the opening in the table.

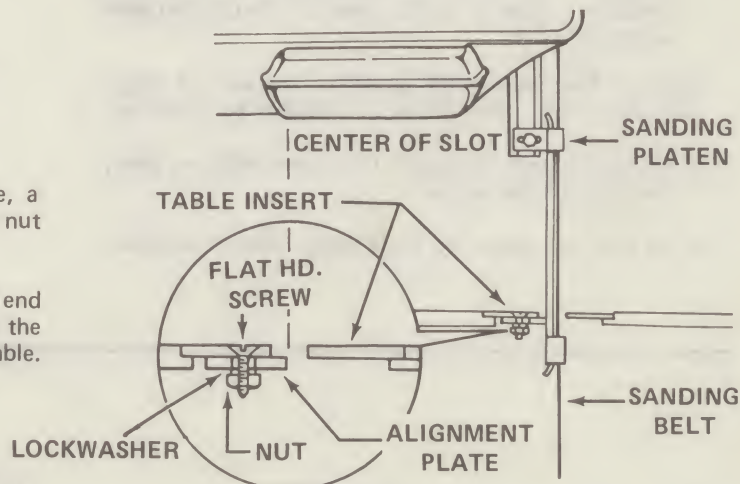

11. Hold a square on the table against the sanding belt and platen.

12. Tighten the hex. head screw which holds the platen to the guide bar.

13. Replace the cover.

WARNING: FOR YOUR OWN SAFETY, DO NOT SAND IRON OR STEEL BECAUSE THE SPARKS COULD IGNITE THE SAWDUST INSIDE YOUR BAND SAW.

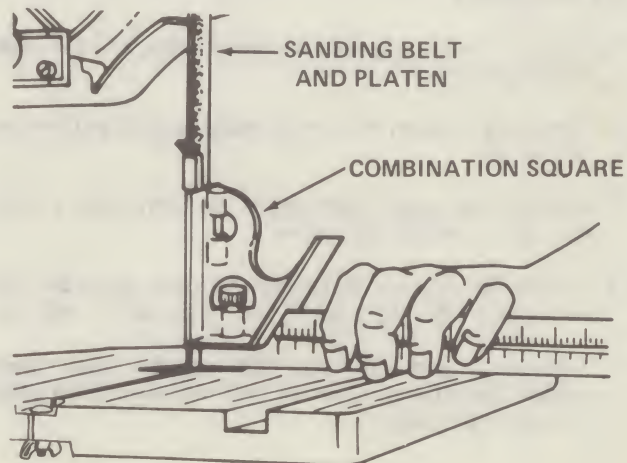

basic band saw/sander operation

BASIC BAND SAW/SANDER OPERATION

A band saw is basically a "curve cutting" machine. It differs from a saw in two respects. It is capable of cutting thicker material and it cuts faster. Unlike a saw, it is not capable of doing inside cutting.

Your Craftsman Band Saw/Sander is not only capable of the usual band saw operations, but it can be converted into a sander as well. You can finish wood, certain compositions and plastics and non-ferrous metals.

SAWING

1. Adjust the upper guides to just clear the workpiece.
2. Use both hands while feeding the work into the blade. Hold the workpiece firmly against the table. Use gentle pressure, and do not force the work, but allow the blade to cut.
3. The smallest diameter that can be cut out is determined by the width of the blade. For example, a $\frac{1}{4}$ " wide blade will cut a minimum diameter of approximately $1\frac{1}{2}$ ". (See Chart)

BLADE SELECTION GUIDE FOR MINIMUM CIRCLE CUTTING

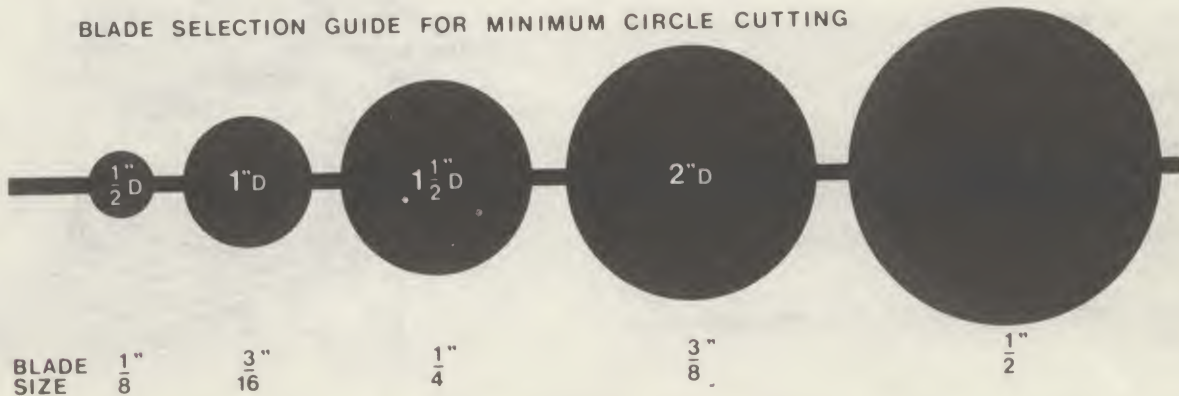

SANDING

The sanding belt cuts very rapidly. Practice with some scraps of wood first before you attempt to sand your actual workpiece.

1. Press the workpiece gently against the sanding belt, and keep moving it until the edge is smooth.

maintenance

WARNING: FOR YOUR OWN SAFETY, TURN SWITCH "OFF" AND REMOVE PLUG FROM POWER SOURCE OUTLET BEFORE MAINTAINING OR LUBRICATING YOUR BAND SAW.

TIRES

Pitch and sawdust that accumulate on the tires should be removed with a stiff brush or scraped off with a piece of wood. Do not use a sharp knife or any kind of solvent.

When the tires become worn they should be replaced. When replacing the tires, stretch them around the wheels but do not glue them on.

GENERAL

Keep your Band Saw/Sander clean.

Remove the sawdust from the inside.

Do not allow pitch to accumulate on the table, the insert, the guides or the thrust bearings. Clean them with Craftsman Gum and Pitch Remover. **CAUTION: Do not immerse the thrust bearings.**

Apply a thin coat of automobile-type wax on the table so that the wood slides easily while cutting.

MOTOR

Frequently blow out any sawdust from the motor.

If the power cord is worn or cut, or damaged in any way, have it replaced immediately.

For motor maintenance, follow instructions furnished with the motor.

LUBRICATION

All of the **BALL BEARINGS** are packed with grease at the factory. They require no further lubrication.

For motor lubrication, follow instructions furnished with the motor.

Periodically apply a few drops of oil to the upper wheel guide rods.

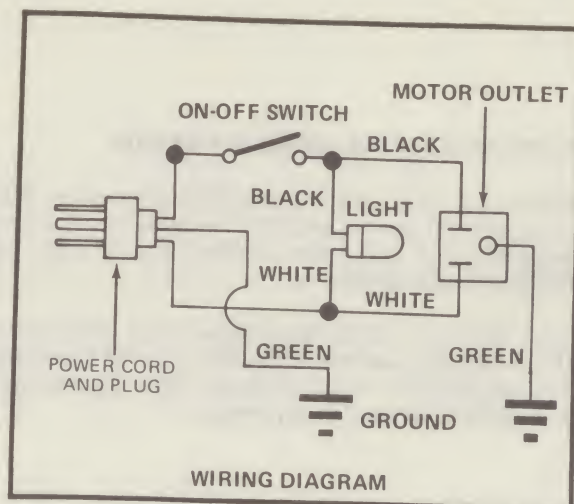

WHEEL NOT SHOWN FOR PICTURE CLARITY

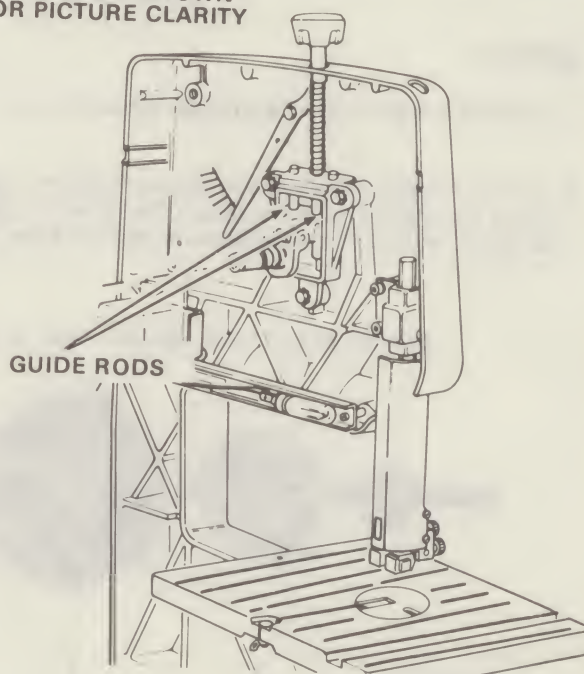

RECOMMENDED ACCESSORIES

Item	Cat. No.
Floor Base	9-22213
Miter Gauge	9-29929
Hold-Down Clamp for Miter Gauge	9-29928
Stop-Rods for Miter Gauge	9-29924
Rip Fence	9-23433
Blades and Sanding Belts	See Catalog
Steel Leg Set	9-22236
Circle Cutting Attachment	9-24301
Table Extension	9-24302
Speed Reducer	9-238961
Power Tool Know How Handbooks	
Radial Saw	9-2917
Table Saw	9-2918

The above recommended accessories are current and were available at the time this manual was printed.

trouble shooting

WARNING: FOR YOUR OWN SAFETY, TURN SWITCH "OFF" AND REMOVE PLUG FROM POWER SOURCE OUTLET BEFORE TROUBLE SHOOTING YOUR BAND SAW/SANDER.

TROUBLE	PROBABLE CAUSE	REMEDY
Motor will not run.	<ol style="list-style-type: none"> 1. Defective On-Off switch. Defective switch cord. Defective switch box receptacle. 2. Motor protector open, (only if your motor is equipped with an overload protector). Other cause. 	<ol style="list-style-type: none"> 1. Replace defective parts before using Band Saw/Sander again. 2. Consult Sears Service. Any attempt to repair this motor may create a HAZARD unless repair is done by a qualified service technician. Repair service is available at your nearest Sears Store.
Blade does not run in the approximate center of the upper wheel.	<ol style="list-style-type: none"> 1. Not tracking properly. 	<ol style="list-style-type: none"> 1. Adjust tracking, see Assembly Section, "Installing the Blade."
Blade does not run in the approximate center of the lower wheel.	<ol style="list-style-type: none"> 1. Lower wheel not positioned correctly on shaft. 	<ol style="list-style-type: none"> 1. Reposition the wheel, see Assembly Section, "Installing the Blade."
Band Saw slows down when cutting.	<ol style="list-style-type: none"> 1. Belt too loose. 2. Motor pivots in motor base. 3. Cutting too small a radius. 4. Dull blade. 	<ol style="list-style-type: none"> 1. Adjust belt tension, see Assembly Section, "Attaching Belt Guards." 2. Tighten motor base clamp screws. See Assembly Section, "Motor Installation". 3. Stop feeding, and back up the material slightly, until the band saw speeds up. 4. Replace blade.
Blades breaking.	<ol style="list-style-type: none"> 1. Too much tension. 2. Kink in blade caused by cutting too small a radius or turning the material too fast when cutting. 	<ol style="list-style-type: none"> 1. Adjust tension. See Getting To Know Your Band Saw/Sander, "3 Tension Scales." 2. Use correct cutting technique. See Basic Band Saw/Sander Operation Section.

FIGURE 1 SUPPLIED WITH MODEL 113.243411 ONLY

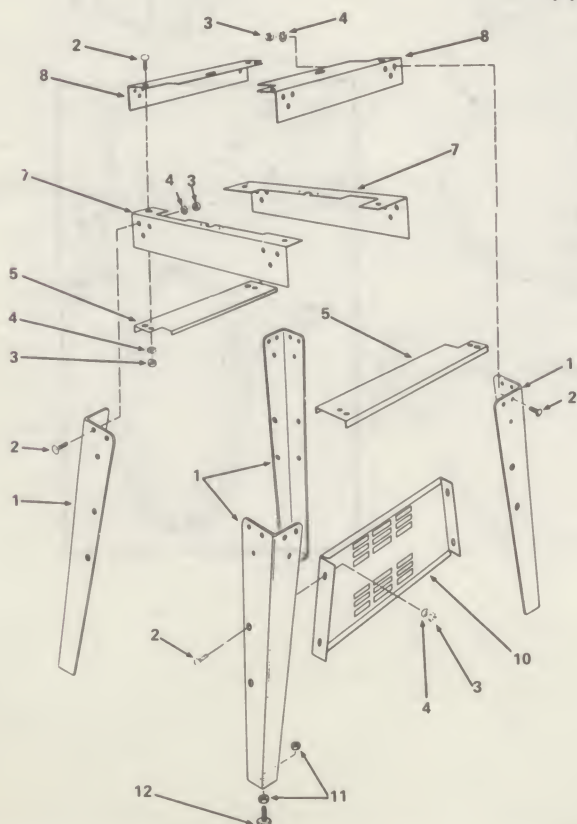

Key No.	Part No.	Description
1	62614	Leg
2	60314	†*Screw Truss Hd. 1/4-20 x 5/8
3	STD541025	†*Nut Hex 1/4-20
4	STD551225	†*Lockwasher, 1/4 External
5	68060	Channel, Support
7	68059	Stiffener, Side
8	62615	Stiffener, End
10	68061	Support, Motor
11	STD541050	†*Nut, Hex Hd. 1/2-13
12	803835	† Foot, Leveling
	69097	*Bag of Loose Parts
HARDWARE FOR MOUNTING TOOL & MOTOR		
	STD523110	†*Screw, Hex Hd. 5/16-18 x 1
	STD551131	†*Lockwasher Ext. 5/16
	STD541231	†*Nut, Hex Jam 5/16-18
	STD551031	†*Washer 11/32 x 11/16 x 1/16
	STD532507	†*Bolt, Carriage 5/16-18 x 3/4

* Standard Hardware Item — May Be Purchased Locally
 † All Parts Contained In Loose Parts Bag

repair parts

CRAFTSMAN 12-INCH BAND SAW/SANDER, MODEL 113.243401 & 113.243411

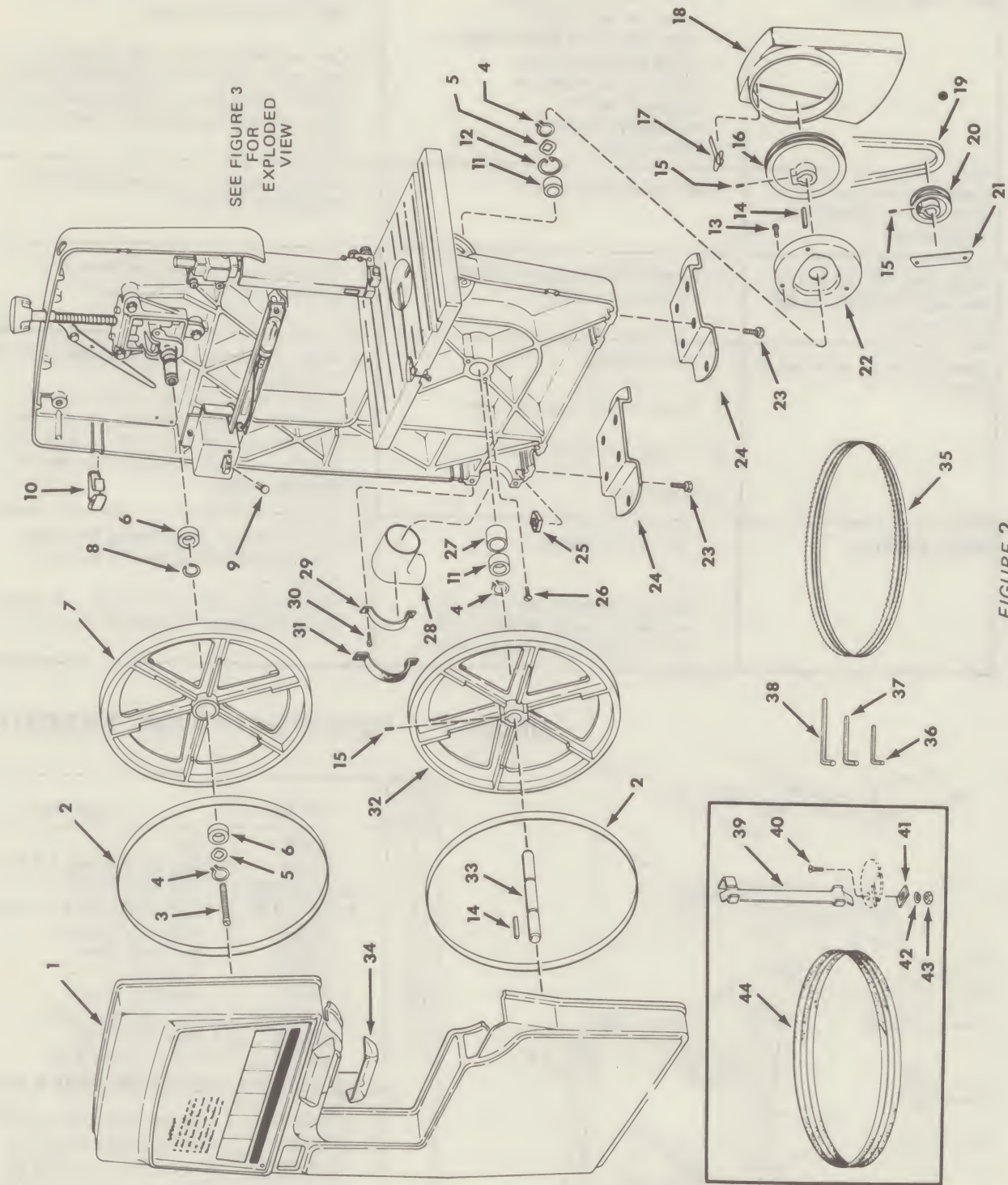

CRAFTSMAN 12-INCH BAND SAW/SANDER, MODEL 113.243401 & 113.243411

Always order by Part Number — not by Key Number

FIGURE 2 PARTS LIST

KEY NO.	PART NO.	DESCRIPTION	KEY NO.	PART NO.	DESCRIPTION
1	69069	Cover, Frame with Trim	23	453068	*Screw, 5/16-18 x 3/4, Sems, Hex, Hd.
2	41815	Tire	24	69084	Foot, Frame
3	38524	Screw, Self-Locking	25	STD541031	*Nut, Square, 5/16-18
4	37158	Ring, Retaining 5/8	26	STD522503	*Screw Mach., 1/4-20 x 3/8, Truss Hd., Slotted.
5	41711	Washer, Spring	27	69023	Spacer, Bearing
6	STD315228	Bearing, Ball	28	65013	Elbow
7	69028	Wheel, Upper Drive	29	69004	Clamp, Tube
8	41812	Ring Internal Retaining 1-3/8	30	STD601103	*Screw, Mach., 10-32 x 3/8, Pan Hd.
9	60256	Key, Switch	31	69078	Gasket, Foam
10	69085	Clip	32	69059	Wheel, Lower Drive
11	60251	Bearing, Ball	33	69058	Shaft, Lower Wheel
12	38884	Ring, Internal Retaining 1-11/16	34	69025	Lens
13	STD601105	*Screw Type 23, 10-32 x 1/2, Pan Hd.	35	60272	†Blade, Band Saw, 1/4 x 80
14	STD580104	*Key, Square 3/16 x 1-1/4	36	37887	†Wrench, Hex., "L", 1/8
15	STD503105	*Screw, Set, 5/16-18 x 1/2, Soc. Hd., Cup Pt.	37	60096	†Wrench, Hex., "L", 5/32
16	38450	†Pulley, 1/2 V Groove, 5" x 5/8	38	37911	†Wrench, Hex., "L", 3/16
17	60255	Bore, Keyed with Set Screw	39	69062	Platen, Sanding
18	60252	Clip, "S"	40	133427	*Screw, Mach., 6-32 x 7/16, Flat Hd.
19	STD304520	Guard, Belt	41	69005	Plate, Sanding Alignment
20	30646	†Belt "V" Type, 1/2 x 52	42	STD551106	* Lockwasher, No. 6
21	60254	†Pulley, 1/2 V Groove, 2-1/2" x 5/8	43	STD541006	* Nut, Hex., 6-32
22	60253	Bore, Keyed with Set Screw Bracket, Support Support, Belt Guard	44	69037	†Belt, Sanding, 1/2 x 80
				69098	Owner's Manual (Not Illustrated)
				69086	Bag Asm. Loose Parts (Not Illustrated)
				69088	Bag Asm. Loose Parts (Not Illustrated)

*Standard Hardware Item — May Be Purchased Locally.

†Stock Item — May be secured through the Hardware Department of most Sears or Simpsons-Sears Retail Stores or Catalog Order Houses.

repair parts

CRAFTSMAN 12-INCH BAND SAW/SANDER, MODEL 113.243401 & 113.243411

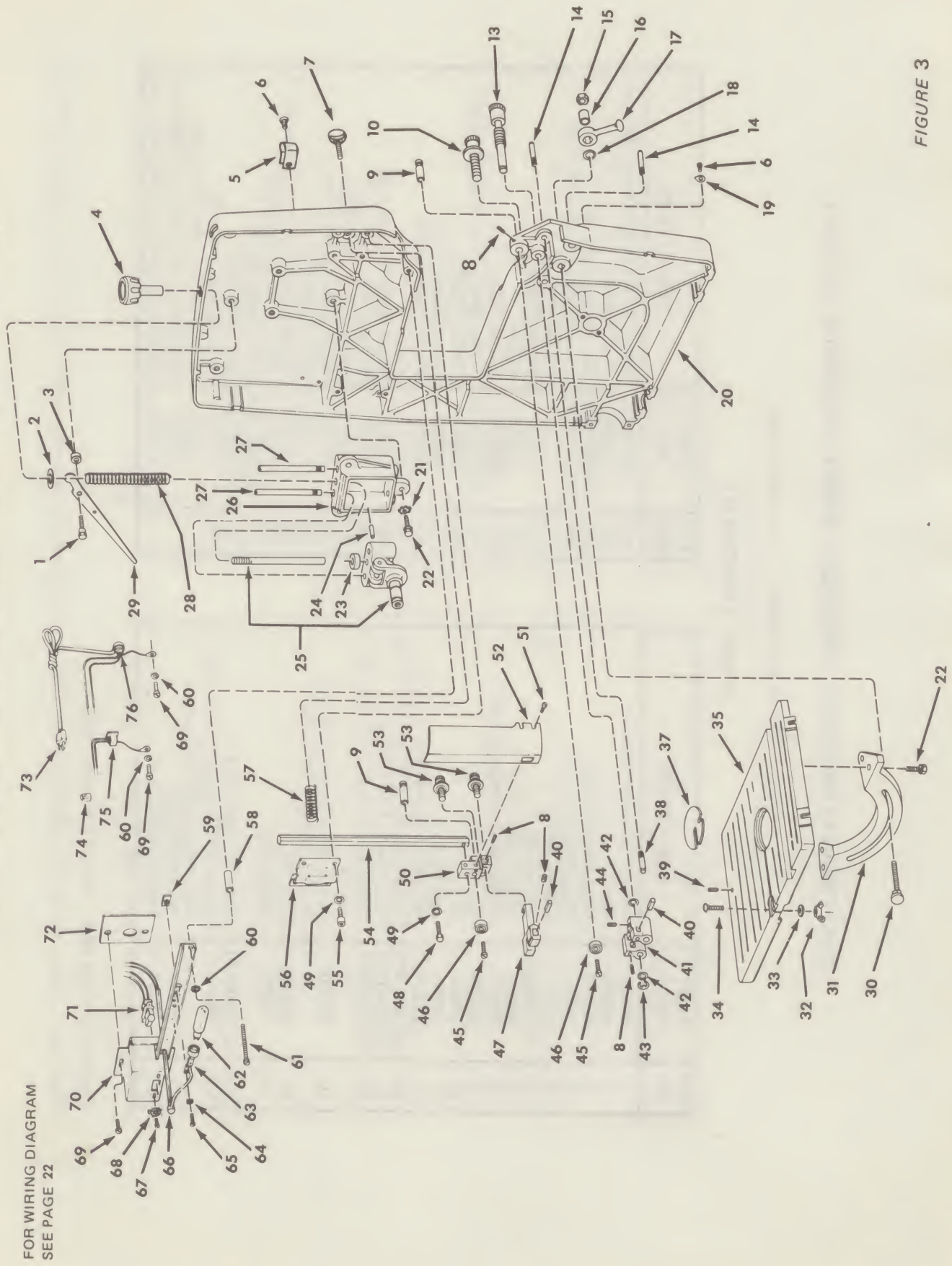

FOR WIRING DIAGRAM
SEE PAGE 22

FIGURE 3

CRAFTSMAN 12-INCH BAND SAW/SANDER, MODEL 113.243401 & 113.243411

FIGURE 3 PARTS LIST

KEY NO.	PART NO.	DESCRIPTION	KEY NO.	PART NO.	DESCRIPTION
1	STD522503	*Screw Hex Hd, Ty "T", 1/4-20 x 3/8	39	60190	Screw, Self-Locking, 5/16-18 x 3/8
2	60386	Washer, Plain, 15/32 x 1-1/2 x 1/8	40	69039	Guide, Blade
3	63266	Bushing	41	69045	Guide, Lower Blade
4	69031	Knob Assy., Tension Adjustment	42	STD551031	*Washer, Plain, 5/16 x 9/16 x 1/16
5	30613	Clamp, Cord	43	STD581031	Ring, Retaining, 5/16
6	STD600803	*Screw, Type 23, 8-32 x 3/8 Pan Hd.	44	STD502505	*Screw, Set, 1/4-20 x 3/4, Soc. Hd., Fl. Pt.
7	60321	Screw, Thumb 5/16-18 x 1-1/2	45	STD512505	*Screw, Mach., 1/4-20 x 1/2, Pan Hd.
8	STD502502	*Screw, Set, 1/4-20 x 1/4 Soc. Hd., Fl. Pt.	46	STD315505	Bearing, Ball
9	69042	Sleeve, Thrust Bearing	47	69038	Guide, Upper Blade
10	69099	Knob Assy., Thrust Adjustment	48	STD522508	*Screw, Mach., 1/4-20 x 7/8, Hex. Hd.
13	69100	Knob Assy., Guide Adjustment	49	STD551125	*Lockwasher, 1/4
14	69021	Pin, Trunnion	50	69041	Support, Upper Blade
15	STD541037	*Nut, Hex. 3/8-16	51	STD601103	*Screw, Type 23, 10-32 x 5/16, Pan Hd.
16	69077	Spacer	52	69044	Guard
17	69072	Wrench	53	69043	Knob Upper Guide
18	STD551037	*Washer, Plain, 3/8 x 1-1/8 x 7/64	54	69035	Bar, Guide
19	38724	Pointer, Tilt	55	216278	*Screw, Cap, 1/4-20 x 1/2, Socket, Hd.
20	69070	Frame Assy., (Incl. Key Nos. 14 & 36)	56	69036	Support, Guide Bar
21	STD551131	*Lockwasher Ext. 5/16	57	69034	Spring, Guide Bar
22	9416187	*Screw, Hex. Hd. 5/16-18 x 3/4	58	69012	Spacer
23	69029	Bumper, Upper Wheel	59	30682	*Nut, Speed
24	STD572507	Pin Roll 1/4 x 3/4	60	STD551225	*Lockwasher, External Tooth 1/4
25	69068	Guide Assy., Fulcrum (includes Key No. 24)	61	STD522512	*Screw, Mach., 1/4-20 x 1-1/4, Pan Hd.
26	41426	Bracket, Upper Wheel Support	62	STD372252	*Bulb, Light 115/125V, 25 Watt, Dbl. contact, Bayonet Base, Appliance Socket, Light
27	69022	Rod, Upper Wheel Guide	63	69014	Socket, Light
28	69019	Spring, Wheel Tension	64	STD551208	*Lockwasher No. 8
29	69089	Pointer	65	STD510802	*Screw Mach., Pan Hd. 8-32 x 1/4
30	STD533725	*Bolt, Carriage, 3/8-16 x 2-1/2	66	69009	Relief, Strain
31	69057	Trunnion	67	STD600603	*Screw, 6-32 x 3/8, Pan Hd.
32	STD541625	*Nut Wing 1/4-20	68	STD551206	Lockwasher, Int. 6
33	STD551025	*Washer 9/32 x 5/8 x 1/16	69	447845	Screw, Type T, 1/4-20 x 1/2, Pan Hd.
34	60323	Screw, Truss Hd 1/4-20 x 1 Table	70	69010	Box Assy., Switch
35	69094	Insert Table	71	60257	Switch, Locking
37	69063	Pin, Lower Guide Support	72	69082	Gasket, Switch Box
38	69024	Pin, Lower Guide Support	73	69026	Cord Assembly
			74	STD375006	*Connector, Wire, 14-18
			75	69027	Outlet Assembly
			76	37875	Relief, Strain

*Standard Hardware Item - May Be Purchased Locally.

†Stock Item - May be secured through the Hardware Department of most Sears or Simpsons-Sears Retail Stores or Catalog Order Houses.

Sears

*owners
manual*

SERVICE

**MODEL NO.
113.243401**

SAW ONLY

**MODEL NO.
113.243411**

SAW WITH LEGS
AND MOTOR

**HOW TO ORDER
REPAIR PARTS**

**12-INCH BAND SAW/
SANDER**

Now that you have purchased your 12-Inch Band Saw/Sander should a need ever exist for repair parts or service, simply contact any Sears Service Center and most Sears, Roebuck and Co. stores. Be sure to provide all pertinent facts when you call or visit.

The model number of your 12-Inch Band Saw/Sander will be found on a plate at the right-hand side of the saw.

WHEN ORDERING REPAIR PARTS, ALWAYS GIVE THE FOLLOWING INFORMATION:

PART NUMBER	PART DESCRIPTION
MODEL NUMBER 113.243401 or 113.243411	NAME OF ITEM 12-Inch Band Saw/Sander

All parts listed may be ordered from any Sears Service Center and most Sears stores. If the parts you need are not stocked locally, your order will be electronically transmitted to a Sears Repair Parts Distribution Center for handling.

Sold by SEARS, ROEBUCK AND CO., Chicago, IL. 60684 U.S.A.