

Cuisinart®

INSTRUCTION
AND RECIPE
BOOKLET



Cuisinart® Core Custom™ 13-Cup Food Processor

FP-130 Series

For your safety and continued enjoyment of this product, always read the instruction book carefully before using.



IMPORTANT UNPACKING INSTRUCTIONS

This package contains a Cuisinart® Core Custom™ 13-Cup Food Processor and the accessories for it: 13-cup work bowl, work bowl cover with small, medium, and large pushers, metal chopping/mixing/dough blade, reversible shredding disc, adjustable slicing disc, removable stem adapter, storage hub, base and instruction/recipe book.

CAUTION:

THE CUTTING TOOLS HAVE VERY SHARP EDGES.

To avoid injury when unpacking the parts, please follow these instructions.

1. Place the box on a low table or on the floor next to the kitchen counter where you intend to keep the food processor. Be sure the box is right side up.
2. Open top flaps—there will be a rectangular block of packing material that holds the processor parts, each fitted into a cavity.
3. Remove the instruction/recipe book.
4. Lift out the packing material.
5. Remove the base and bowl and place them on the counter or table. Read the instructions thoroughly before using the machine.
6. Save the shipping carton, box and packing material. You will find these very useful if you need to repack the processor for moving or other shipment.

We recommend that you visit our website, www.cuisinart.com, for a fast, efficient way to complete your product registration.

IMPORTANT SAFEGUARDS

Always follow these safety precautions when using this appliance.

Getting Ready

1. Read all instructions.
2. **Blade and discs are sharp.** Handle them carefully.
3. **Always turn off and unplug appliance from outlet when not in use, before putting on or taking off parts, before removing food and before cleaning. To unplug, grasp plug and pull from electrical outlet. Never pull cord.**

4. Do not use outdoors.
5. Do not let cord hang over edge of table or counter, or touch hot surfaces.
6. Do not operate any appliance that has a damaged cord or plug or after it has been dropped or damaged in any way. Contact Cuisinart Consumer Service Center at 1-800-762-0190 for information on examination, repair, or adjustment.

Operation

1. Keep hands as well as spatulas and other utensils away from moving blade or discs while processing food to prevent the possibility of severe personal injury or damage to food processor. A plastic scraper may be used, but only when the food processor motor is stopped.
2. Avoid coming into contact with moving parts. Never push food down by hand when slicing or shredding. Always use pusher.
3. Make sure motor has completely stopped before removing cover. (If machine does not stop within 4 seconds after you remove the bowl cover assembly, call 1-800-762-0190 for assistance. Do not use the machine.)
4. Never store any blade or disc on stem adapter. To reduce the risk of injury, no blade or disc should be placed on the shaft except when the bowl is properly locked in place and the processor is in use. Store blades and discs as you would sharp knives, out of reach of children.
5. Be sure cover and feed tube are securely locked in place before operating food processor.
6. Never feed food by hand. Always use the pusher.
7. Never try to override or tamper with cover interlock mechanism.

Cleaning

To protect against risk of electric shock, do not put base in water or other liquids.

General

1. This appliance should not be used by or near children or individuals with certain disabilities.
2. Do not operate this, or any other motor-driven appliance, while under the influence of alcohol or other substances that affect your reaction time or perception.
3. This food processor is for household use. Use it only for food preparation as described in this accompanying instruction and recipe book. Do not use this appliance for anything but its intended use.
4. When using an approved Cuisinart food processor accessory, read all instructions included with that accessory.

5. The use of attachments not recommended or sold by Cuisinart may cause fire, electric shock or personal injury, or damage to your food processor.
6. To avoid possible malfunction of work bowl switch, never store processor with cover assembly in locked position.
7. Do not operate your appliance in an appliance garage or under a wall cabinet. **When storing in an appliance garage, always unplug the unit from the electrical outlet.** Not doing so could create a risk of fire, especially if the appliance touches the walls of the garage or the door touches the unit as it closes.

Note: This appliance has a polarized plug (one blade is wider than the other). As a safety feature, this plug will fit in a polarized outlet only one way. If the plug does not fit fully in the outlet, reverse the plug. If it still does not fit, contact a qualified electrician. Do not attempt to defeat this safety feature.

Note: This appliance is not intended for use by children or by persons with reduced physical, sensory, or mental capabilities, or lack of experience and knowledge. Close supervision is necessary when any appliance is used near children. Children should be supervised to ensure that they do not play with the appliance.

Do not fill the bowl above the marked maximum fill line (or rated capacity). This could damage the cover or bowl and cause risk of injury.

WARNING: RISK OF FIRE OR ELECTRIC SHOCK



The lightning flash with arrowhead symbol within an equilateral triangle is intended to alert the user to the presence of dangerous uninsulated voltage within the product's enclosure that may be of sufficient magnitude to constitute a risk of fire or electric shock to persons.



The exclamation point within an equilateral triangle is intended to alert the user to the presence of important operating and maintenance (servicing) instructions in the literature accompanying the appliance.

CONTENTS

Important Unpacking Instructions.....	2
Important Safeguards.....	2
Parts	4
Assembly Instructions	5
Machine Controls	5
Machine Functions	5
User Guide	7
Cleaning, Storage and Maintenance.....	8
For Your Safety.....	8
Technical Data.....	8
Troubleshooting.....	9
Warranty Information.....	10
Recipes.....	11

**SAVE THESE
INSTRUCTIONS.
FOR HOUSEHOLD
USE ONLY.**

WARNING

RISK OF FIRE OR ELECTRIC SHOCK
DO NOT OPEN

WARNING: TO REDUCE THE RISK OF FIRE OR ELECTRIC SHOCK,

DO NOT REMOVE COVER (OR BACK)

NO USER-SERVICEABLE PARTS INSIDE

REPAIR SHOULD BE DONE BY AUTHORIZED SERVICE PERSONNEL ONLY

PARTS

The machine includes:

1. **Housing base** — With convenient paddle controls
2. **13-cup removable work bowl**
3. **Cover with feed tube**
4. **Small, medium, and large pushers** — Slide inside the feed tube
5. **Stem adapter**
6. **Metal chopping/mixing/dough blade**
7. **Reversible shredding disc** — Provides the option of either fine or medium shredding for optimal results
8. **Adjustable slicing disc** — This versatile 7-in-1 disc allows for thin to thick slices with 1mm to 7mm indicators
9. **Storage hub** — Stores stem adapter, blade and discs inside the work bowl (for storage use only)
10. **BPA free** (not shown) — All materials that come in contact with food or liquid are BPA free

Note: Cuisinart offers Cuisinart Core Essentials™, a line of accessories for your food processor that can be purchased separately. The selected accessory connects to the food processor housing base, so you can turn your food processor into a blender, juicer, dicer and more!

AVAILABLE ACCESSORIES:

ACCESSORY NAME	MODEL #
36 oz. Blender Jar	MFP-B36
Juicing Center	MFP-JC
4-Cup Small Work Bowl	MFP-WB4
Dicing Kit	FP-DC

Visit Cuisinart.com to purchase!

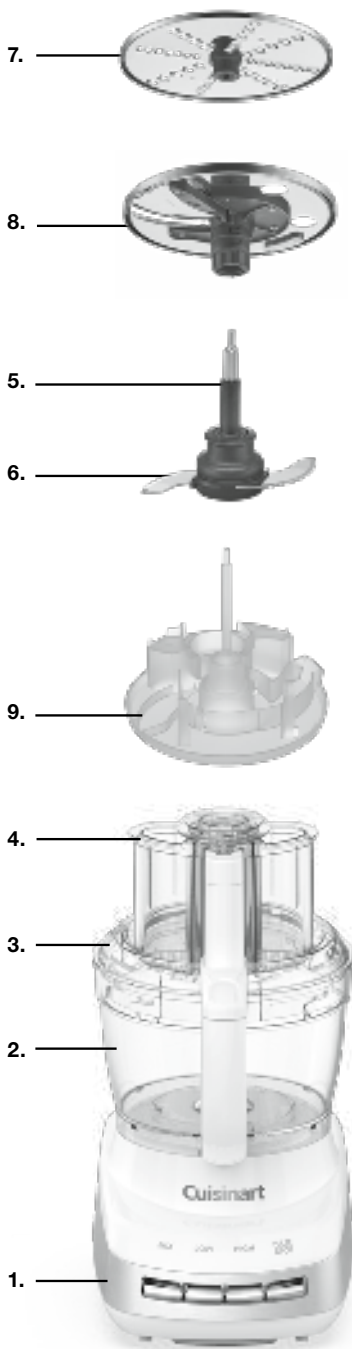

ASSEMBLY INSTRUCTIONS

Before First Use

Before using your Cuisinart® Core Custom™ 13-Cup Food Processor for the first time, wash the work bowl, work bowl cover, pushers, blade and discs (see cleaning instructions on page 8).

1. Place the food processor base on a dry, level countertop with the controls facing you. Do not plug the unit in until it is fully assembled.
2. With the bowl on the base, use the handle to turn the work bowl clockwise to lock it onto the housing base.

CHOPPING/MIXING/ DOUGH BLADE

1. Place the work bowl on top of base, with the work bowl handle just to the right of center. Turn the work bowl clockwise to lock it onto the housing base.
2. Carefully place the blade onto the stem adapter. Holding top of stem adapter, lift and place over the work bowl accessory adapter. Blade should rest on the bottom of the work bowl.

NOTE: To remove the blade from the stem adapter - lift the stem adapter from the work bowl and place on a flat countertop. Press down on the stem adapter to loosen the metal blade. Grasping the center hub of the blade carefully lift off the stem adapter.

3. Plug in the housing base.
4. Add desired ingredients to work bowl.
5. Place work bowl cover on work bowl, with the feed tube just to the right of center. Turn clockwise to lock onto work bowl.
6. Align pusher assembly with the feed tube opening on the work bowl cover and slide down to the bottom.
7. The machine is now ready for use.

SLICING AND SHREDDING DISCS

1. Place the work bowl on top of the base, with the work bowl handle just to the right of center. Turn the work bowl clockwise to lock it onto the housing base.
2. Insert stem adapter **without blade**.
3. Choose desired disc.
 - If using the adjustable slicing disc, use the rotating hub and indicator markings to select slicing thickness from 1 to 7 (1 = thin slice, 7 = thick slice). Using the two finger holes located on the disc, align and insert the disc over the stem adapter.

- If using the reversible shredding disc, determine whether the fine or medium side will be used and use the plastic hub to twist into position on the stem adapter. The plastic hub may be used for removal of this disc.
4. Place work bowl cover onto work bowl, with the feed tube just to the right of center. Turn clockwise to lock onto work bowl.
 5. Align the pushers with the feed tube opening on the work bowl cover and slide down to the bottom.
 6. Plug in the housing base.
 7. The machine is now ready for use.

MACHINE CONTROLS

High, Low, and Mix Control Paddles

The High, Low, and Mix controls are paddles that allow the machine to run until Off is selected. The Mix paddle is a unique function that allows for mixing at just the right speed for a wide range of mixing tasks.

1. Properly assemble the machine.
2. Add ingredients to the work bowl, either through the feed tube or directly into the bowl.
3. Press the High, Low, or Mix paddle. The white LED light will illuminate and the motor will start.
4. Press the Off paddle when finished.

Pulse Paddle

The Pulse control is a paddle that allows the machine to run only while it is being pressed. This capability provides more accurate control of the duration and frequency of processing. Unless otherwise specified, a pulse should be about one second.

With the machine properly assembled and ingredients in the work bowl, press the Pulse paddle repeatedly as needed. The white LED light will illuminate upon activation.

MACHINE FUNCTIONS

Using the Chopping/Mixing/Dough Blade

Chopping

- For raw ingredients: Peel, core, and/or remove seeds and pits. Food should be cut into even, ½- to 1-inch pieces. Foods cut into same size pieces produce the most even results.
- Pulse food in 1-second increments to chop. For the finest chop, either hold the Pulse paddle down or press High or Low to run the machine continuously. Watch ingredients closely to achieve desired consistency and scrape the work bowl as necessary. High speed is recommended for most chopping and processing tasks.

Puréeing

- To purée fresh fruits or cooked fruits/vegetables: Ingredients should be cut into 1-inch pieces; a smooth purée is best achieved when all the pieces are equal in size. Pulse to initially chop and then process on High or Low until food is puréed; scrape the work bowl as necessary. **Note: Do not use this method to purée cooked white potatoes.**
- To purée solids for a soup or sauce: Strain the solids from the liquid and process the solids alone. Add cooking liquid and process as needed.

Mixing

- The Mixing function is designed to gently mix doughs and other items without over-processing. It is perfect for incorporating chips and nuts into a cookie dough or lightly mixing a muffin batter or scone dough, ensuring that the mix-ins remain intact. It also is excellent for savory items such as guacamole when a nice and chunky mixture is desired.
- It is important that all ingredients are evenly distributed in the work bowl first before adding additional mix-in ingredients (e.g. chocolate chips, nuts, etc.).

Dough

- Always use Low speed when kneading yeasted doughs. Be sure that the medium pusher lock is in the locked position when kneading dough to avoid it from moving around — some vibration is normal. Always start the food processor before adding liquid. First process the dry ingredients (flour, salt, etc.) and then add the liquid in a slow, steady stream or through the drizzle hole in the pusher, allowing the dry ingredients to absorb it. If liquid is added too quickly, wait until ingredients in the work bowl have mixed, then add remaining liquid slowly (do not turn off the machine). Never use more than 4 cups of white/all-purpose flour when preparing a yeasted dough.

Using the Reversible Shredding and Adjustable Slicing Discs

- The slicing disc makes whole slices. It slices fruits and vegetables, cooked meat and semi-frozen raw meat. The shredding disc shreds most firm and hard cheeses. It also shreds vegetables like potatoes, carrots and zucchini.
- Always pack food in the feed tube evenly for slicing and shredding. The food will dictate the amount of pressure: Use light pressure for soft foods, medium pressure for medium foods and firm pressure for harder foods. Always process with even pressure.
- For round fruits or vegetables: Remove a thick slice on the bottom of the food so that it sits upright in the feed tube. If food does not fit in the feed tube, cut in half or quarters to fit. Process with even pressure.
- For small ingredients like mushrooms, radishes or strawberries: Trim the ends so the food sits upright in the feed tube.
- When slicing or shredding cheese, be sure that the cheese is well chilled.
- To shred leafy vegetables like lettuce or spinach: Roll leaves together and stand them up in feed tube. Process with even pressure.

Note: Always use the pusher when slicing or shredding. Never put your hands in the feed tube while unit is running.

RECOMMENDED MAXIMUM WORK BOWL CAPACITY

FOOD	CAPACITY
Sliced or shredded fruit, vegetables or cheese	12 cups
Chopped fruit or vegetable	6 cups
Chopped cheese	4½ cups
Puréed fruit or vegetables	6 cups cooked; 4 cups puréed
Chopped or puréed meat, fish or seafood	2 pounds
Thin liquid (e.g., dressings, soups, etc.)	9 cups
Cake batter	8-inch cheesecake batter; 1 box (15.25 ounce) cake mix
Cookie dough	5 dozen (based on average chocolate chip cookie recipe)
White bread/pizza dough	4 cups (all-purpose or bread flour)
Nuts for nut butter	4 cups

USER GUIDE

You can slice, shred and chop a multitude of vegetables and fruits in the Cuisinart® Food Processor. What you may not know is that the food processor is the perfect tool for a number of other tasks, such as softening butter, making breadcrumbs, making baby food, etc. Here is a guide that will help you in preparing just about anything!

FOOD	TOOL	SPEED	DIRECTIONS
Soft Cheeses (ricotta, cream cheese, cottage cheese, etc.)	Chopping/Mixing/ Dough Blade	Low or High	Bring cheese to room temperature. When applicable, cut into 1-inch pieces. Process until smooth, stopping to scrape down the sides of the bowl as needed. Perfect for making cheesecakes, dips, pasta fillings and more.
Firm Cheeses (Cheddar, Swiss, Edam, Gouda, etc.)	Slicing or Shredding Disc	Shredding: Low or Mix Slicing: Low or High	Cheese should be well chilled before slicing/shredding. Cut to fit feed tube. Use light to medium pressure when slicing/shredding.
Hard Cheeses (Parmesan, Romano, etc.)	Chopping/Mixing/ Dough Blade Slicing or Shredding Disc	Shredding: Low or Mix; Slicing: Low	If using the chopping blade, cut into ½-inch pieces. Pulse to break up and then process until finely grated. This will produce a nicely grated cheese. If slicing or shredding, cut to fit feed tube. Use light to medium pressure when slicing/shredding.
Baby Food	Chopping/Mixing/ Dough Blade	Pulse and Low, High, or Mix	For all fruit and vegetable purées, cut ingredients into ½- to 1-inch pieces. Steam ingredients until completely soft. Pulse to chop, then process until completely smooth (add steaming liquid through the feed tube when processing if necessary). To ensure there are no lumps, press mixture through a fine mesh strainer. Keeps frozen in ice cube trays for individual 1-ounce portions.
Butter	Chopping/Mixing/ Dough Blade Slicing or Shredding Disc	High	<i>For creaming:</i> Bring butter to room temperature. Cut into 1-inch pieces. Process, scraping bowl as necessary. For compound (flavored) butters, process flavoring ingredients, such as herbs, zest, vegetables, etc., before adding butter. <i>For shredding/slicing:</i> Freeze briefly. Use light to medium pressure to shred or slice. Shredded butter is great for preparing certain pastry doughs. Sliced butter is great for serving alongside corn on the cob or freshly made rolls.
Crumbs (bread, cookie, cracker, chip)	Chopping/Mixing/ Dough Blade	High	Break into pieces. Pulse to break up further, and then process until desired consistency. This will make perfect bread/cracker/chip crumbs for coating meats and fish. Processed cookies make delicious pie and cake crusts!
Fresh Herbs	Chopping/Mixing/ Dough Blade	Pulse	Wash and dry herbs VERY well. Pulse to roughly chop. Continue pulsing until desired consistency is achieved.
Ground Meat	Chopping/Mixing/ Dough Blade	Pulse and High	Cut meat into ½-inch pieces. Pulse to chop — about 14 long pulses or until desired consistency is achieved. If a purée is desired, continue to process. Never chop/purée more than 1½ pounds at one time.
Ice Cream	Chopping/Mixing/ Dough Blade	High	Put frozen fruit cut into 1-inch pieces into the work bowl with liquid (juice or milk), any desired sweeteners, such as sugar, honey, simple syrup and other flavors. Process until smooth.
Milk Shakes/ Smoothies	Chopping/Mixing/ Dough Blade	Low	For milk shakes, first add ice cream. While unit is running, add milk through the feed tube until desired consistency is achieved. For smoothies, add fruit first, then add the liquid through the feed tube while unit is running.
Nuts	Chopping/Mixing/ Dough Blade	Pulse and High	Pulse to chop to desired consistency. To make a nut butter, pulse to break up, and then process until smooth, stopping to scrape down as needed.
Superfine Sugar	Chopping/Mixing/ Dough Blade	High	Process granulated sugar for about 1 minute until finely ground. Excellent for using in meringues and other baked goods.
Whipped Cream	Chopping/Mixing/ Dough Blade	Low	Process well-chilled cream until cream begins to thicken. Add sugar as desired; process continuously until cream reaches desired consistency. This cream is dense and perfect as a whipped topping for cake or ice cream.

CLEANING, STORAGE AND MAINTENANCE

- Keep your Cuisinart® Core Custom™ 13-Cup Food Processor ready to use on the kitchen counter. When not in use, leave it unplugged. Store accessories in the provided storage hub, inside the work bowl.
- Keep the blade and discs out of the reach of children.
- All parts except the housing base are dishwasher safe but on the **top rack only**. Due to intense water heat, washing the work bowl, cover and accessories on the bottom rack may cause damage over time. Place the cover with the feed tube facing up to ensure proper cleaning. Place the work bowl and pushers upside down for drainage. Remember to unload the dishwasher carefully when removing sharp blade and discs.
- To simplify cleaning, rinse the work bowl, cover, pushers and blade or disc immediately after use so food won't dry on them. Be sure to position the pushers and work bowl upside down for drainage. If food lodges in the pusher, remove it by running water through it, or use a bottle brush.
- If you wash the blade and discs by hand, do it carefully. When handling, use the plastic hubs. Avoid leaving them in soapy water where they may disappear from sight. If necessary, use a brush.
- The work bowl is made of Tritan® plastic with metal components. It should not be placed in a microwave oven.
- The housing base may be wiped clean with a soapy, nonabrasive cloth or sponge. Be sure to dry it thoroughly.
- If the feet leave spots on the counter, spray them with a spot remover and wipe with a damp sponge.
- If any trace of the spot remains, repeat the procedure and wipe the area with a damp sponge and nonabrasive cleaning powder.

IMPORTANT: Always use the provided storage hub. Never store any blade or disc on the stem adapter. No blade or disc should be placed on the shaft except when the processor is about to be used.

MAINTENANCE: Any other servicing should be performed by an authorized service representative.

FOR YOUR SAFETY

Like all powerful electrical appliances, a food processor should be handled with care. Follow these guidelines to protect yourself and your family from misuse that could cause injury.

- Handle and store metal blade and discs carefully utilizing the provided storage hub. Their cutting edges are very sharp.

- Never put stem adapter into the work bowl until the work bowl is locked into place.
- Always be sure that the blade or disc is down on the stem adapter as far as it will go.
- Always insert the stem adapter with metal blade in the work bowl before putting ingredients in bowl.
- When slicing or shredding food, always use the pusher. Never put your fingers or spatula into feed tube.
- Always wait for the blade or disc to stop spinning before you remove the pusher assembly or cover from the work bowl.
- Always unplug the unit before removing food, cleaning or putting on or taking off parts.
- Always remove work bowl from base of machine before you remove the chopping/mixing/dough blade or slicing/shredding disc.
- Be careful to prevent the blade or disc from falling out of the work bowl when emptying the bowl. Remove the stem adapter with blade or disc before tilting the work bowl.

TECHNICAL DATA

The motor in your food processor operates on a standard line operating current. The appropriate voltage and frequency for your machine are shown on a label on the bottom of the base.

An automatic temperature-controlled circuit breaker in the motor ensures complete protection against motor burnout. If the processor runs for an exceptionally long time when chopping, mixing or kneading a thick or heavy mixture in successive batches, the motor may overheat. If this happens, the processor will stop. Turn it off, unplug the unit and wait for the motor to cool before proceeding. It will usually cool within 10 minutes. In extreme cases, it could take an hour.

Safety switches prevent the machine from operating when the work bowl or the cover is not locked into position. The motor stops within seconds when the motor is turned off; and when the pusher assembly is removed, a fast-stop circuit also enables the motor to stop within seconds.

Cuisinart offers a Limited Three-Year Warranty on the entire machine.

TROUBLESHOOTING

Food Processing

1. Problem: The food is unevenly processed.

Solution:

- The ingredients should be cut evenly into ½- to 1-inch pieces before processing.
- Process in batches to avoid overloading.

2. Problem: Slices are uneven or slanted.

Solution:

- Place evenly cut food, cut side down, into the feed tube.
- Apply even pressure on the pusher.

3. Problem: Food falls over in feed tube.

Solution:

- Feed tube should be packed full for best results.

4. Problem: Some food remains on top of the disc.

Solution:

- It is normal for small pieces to remain; cut remaining bits by hand and add to processed ingredients.

5. Problem: Metal chopping/mixing/dough blade cannot be removed from the stem adapter.

Solution:

- Place the blade/stem adapter assembly in a bowl filled with warm tap water. This should help loosen trapped food particles between the blade and stem adapter. To see if food has loosened, remove assembly from water by lifting from the stem. Holding the stem, place the blade assembly on countertop and press down on stem. This should free the blade from the stem. If blade still cannot be removed, return to warm water and repeat above steps.

Mixing

1. Problem: Ingredients are not mixing in evenly.

Solution:

- Be sure that all ingredients are evenly distributed in the work bowl before mixing in additional ingredients.
- If ingredients are concentrated in one area/side of the work bowl, mix-in's may not evenly incorporate when using the Mix function.

Dough Kneading

1. Problem: Motor slows down.

Solution:

- Amount of dough may exceed maximum capacity of your food processor. Remove half and process in two batches.
- Dough may be too wet (see number 8). If motor speeds up, continue processing. If not, add more

flour, 1 tablespoon at a time, until the motor speeds up. Process until dough cleans the sides of the work bowl.

2. Problem: Blade doesn't incorporate ingredients.

Solution:

- Always start the food processor before adding liquid. Add liquid in a slow, steady stream, or through the drizzle hole in the pusher, allowing the dry ingredients to absorb it. If too much liquid is added, wait until ingredients in the work bowl have mixed, then add remaining liquid slowly (do not turn off the machine). Pour liquid onto dough as it passes under feed tube opening; do not pour liquid directly onto bottom of the work bowl.

3. Problem: Blade rises in work bowl.

Solution:

- Excessively sticky dough can cause blade to rise. Carefully reinsert blade and immediately add 2 tablespoons of flour through the feed tube while the machine is running.

4. Problem: Dough doesn't clean inside of the work bowl.

Solution:

- Amount of dough may exceed maximum capacity of your food processor. Remove half and process in two batches.
- Dough may be too dry (see number 7).
- Dough may be too wet (see number 8).

5. Problem: Nub of dough forms on top of blade and does not become uniformly kneaded.

Solution:

- Stop machine, carefully remove dough, divide it into 3 pieces and redistribute them evenly in the work bowl.

6. Problem: Dough feels tough after kneading.

Solution:

- Divide dough into 2 or 3 pieces and redistribute evenly in bowl. Process 10 seconds or until uniformly soft and pliable.

7. Problem: Dough is too dry.

Solution:

- While machine is running, add water, 1 tablespoon at a time, until dough cleans the inside of the bowl.

8. Problem: Dough is too wet.

Solution:

- While machine is running, add flour, 1 tablespoon at a time, until dough cleans the inside of the bowl.

Technical

1. Problem: The motor does not start.

Solution:

- There is a safety interlock to prevent the motor from starting if the processor is not properly assembled. Make sure the work bowl and work bowl cover are securely locked into position.
- If the motor still will not start, check the power cord and outlet.

2. Problem: The food processor shuts off during operation.

Solution:

- The cover may have become unlocked; check to make sure it is securely in position.
- A safety protector in the motor prevents the motor from overheating, which is caused by excessive strain. Press the Off control button, unplug the unit and wait 20 to 30 minutes to allow the food processor to cool off before resuming.

3. Problem: The motor slows down during operation.

Solution:

- This is normal with some heavier loads (e.g., slicing/shredding cheese) that may require the motor to work harder. Simply reposition the food in the feed tube and try again.
- The maximum load capacity may have been exceeded. Remove some of the ingredients and continue processing.

4. Problem: The food processor vibrates/moves around the countertop during processing.

Solution:

- Make sure the rubber feet at the bottom of the unit are clean and dry. Also make sure that the maximum load capacity is not being exceeded.
- This is normal with some heavier loads (e.g., slicing/shredding cheese) that may require the motor to work harder.

WARRANTY

Limited Three-Year Warranty

This warranty is available to U.S. consumers only. You are a consumer if you own a Cuisinart® Core Custom™ 13-Cup Food Processor that was purchased at retail for personal, family or household use. Except as otherwise required under applicable law, this warranty is not available to retailers or other commercial purchasers or owners. We warrant that your Cuisinart® Core Custom™ 13-Cup Food Processor will be free of defects in materials and workmanship under normal home use for 3 years from the date of original purchase.

We recommend that you visit our website, <https://cuisinart.registria.com>, for a fast, efficient way to complete your product registration. However, product registration does not eliminate the need for

the consumer to maintain the original proof of purchase in order to obtain the warranty benefits. In the event that you do not have proof of purchase date, the purchase date for purposes of this warranty will be the date of manufacture.

CALIFORNIA RESIDENTS ONLY

California law provides that for In-Warranty Service, California residents have the option of returning a nonconforming product (A) to the store where it was purchased or (B) to another retail store that sells Cuisinart products of the same type. The retail store shall then, according to its preference, either repair the product, refer the consumer to an independent repair facility, replace the product, or refund the purchase price less the amount directly attributable to the consumer's prior usage of the product. If neither of the above two options results in the appropriate relief to the consumer, the consumer may then take the product to an independent repair facility, if service or repair can be economically accomplished. Cuisinart and not the consumer will be responsible for the reasonable cost of such service, repair, replacement, or refund for nonconforming products under warranty. California residents may also, according to their preference, return nonconforming products directly to Cuisinart for repair or, if necessary, replacement by calling our Consumer Service Center toll-free at **1-800-726-0190**. Cuisinart will be responsible for the cost of the repair, replacement, and shipping and handling for such nonconforming products under warranty.

HASSLE-FREE REPLACEMENT WARRANTY

Your ultimate satisfaction in Cuisinart products is our goal, so if your Cuisinart® Core Custom™ 13-Cup Food Processor should fail within the generous warranty period, we will repair it or, if necessary, replace it at no cost to you. To obtain a return shipping label, please fill out the product inquiry form at www.cuisinart.com/customer-care/product-assistance/product-inquiry/. Or call our toll-free Consumer Service Center at **1-800-726-0190** to speak with a representative.

Your Cuisinart® Core Custom™ 13-Cup Food Processor has been manufactured to the strictest specifications and has been designed for use only in 120-volt outlets and only with authorized accessories and replacement parts. This warranty expressly excludes any defects or damages caused by attempted use of this unit with a converter, as well as use with accessories, replacement parts or repair service other than those authorized by Cuisinart. This warranty does not cover any damage caused by accident, misuse, shipment or other than ordinary household use. This warranty excludes all incidental or consequential damages. Some states do not allow the exclusion or limitation of these damages, so these exclusions may not apply to you. You may also have other rights, which vary from state to state.

Important: If the nonconforming product is to be serviced by someone other than Cuisinart's Authorized Service Center, please remind the servicer to call our Consumer Service Center at **1-800-726-0190** to ensure that the problem is properly diagnosed, the product is serviced with the correct parts, and the product is still under warranty.

Cuisinart

Cuisinart® Core Custom™ 13-Cup Food Processor

Recipe Booklet



Breakfast/Brunch

Apple, Blue Cheese & Walnut Scones	14
Cheddar-Chive Biscuits.....	15
Banana Nut Muffins.....	16
Mushroom and Kale Quiche	17
Maple Breakfast Sausage.....	18
Zucchini Chocolate-Chip Bread.....	19
Energy Protein Bites	20
Acai Smoothie Bowls.....	20
Sweet Almond Chocolate Rolls	21

Butters/Dips/Dressings/Sauces

Scallion-Miso Butter	22
Horseradish Shallot Butter	22
Hot Honey and Pimento Cream Cheese.....	23
Mango-Chile Salsa.....	23
Harissa.....	24
Lemon-Dill Hummus.....	25
Muhammara	25
Guacamole	26
Mayonnaise	26
Basil Pesto	27
Vegan Caesar Dressing.....	28
Lemon Vinaigrette	29
Ranch Dressing.....	29
Radish Raita.....	30
Tzatziki.....	30
Zhug	31

Main Dishes

Loaded Burrito Bowl.....	32
Chicken Tikka Skewers	33
Basic Pasta Dough	34
Butternut Squash Ravioli with Brown Butter and Sage.....	34
Black Bean Veggie Burgers	36
Classic Meatballs.....	37
Lamb Meatballs.....	38
Falafel.....	39
Pizza with Ricotta and Pesto.....	40
Cauliflower Pizza Crust.....	40

Soup/Salads/Sides

Chopped Salad	41
Spicy Cucumber and Avocado Soup.....	41
Parsnip and Kabocha Squash Purée	42

Desserts

Gingerbread Cookies with Icing.....	43
Strawberries & Cream Pinwheel Cookies.....	44
Chocolate Chunk Cookies.....	45
Salted PB&J Blondies.....	46
Plum Crumble Bars.....	47
Banana-Chip "Ice Cream" with Peanut Butter Swirl.....	48
Banana-Chip "Ice Cream" Sandwiches.....	48
Carrot Cake with Cream Cheese Frosting.....	49
Strawberry-Rhubarb Pie.....	50
Pistachio Olive Oil Cake with Cardamom Cream.....	51
Almond Paste.....	52
Sour Cream Cheesecake.....	53

Bread/Dough

Oatmeal Bread.....	54
Popovers.....	54
Whole-Wheat Sandwich Bread.....	55
Pita Bread.....	56
Sour Cream & Onion Potato Pull-Apart Rolls.....	57
Yeast Sweet Dough.....	58
Pizza Dough.....	58
Pretzels with Rosemary and Flake Sea Salt.....	59
Pâte Brisée.....	60

Apple, Blue Cheese & Walnut Scones

These scones are very flavorful, and a drizzle of honey when serving brings them to another level.

Yield: 8 scones

INGREDIENTS

1½	cups cake flour	1	large egg
1	cup unbleached, all-purpose flour, plus more for shaping	6	tablespoons unsalted butter, cut into ½-inch cubes, cold and cubed
1	teaspoon granulated sugar	½	cup dried apples, broken into pieces (if soft dried apples, roughly chop by hand)
1½	teaspoons baking powder		
¼	teaspoon baking soda	¼	cup blue cheese
1	teaspoon fine sea salt		Egg wash (1 large egg plus 1 teaspoon water, whisked well)
¼	cup walnuts, toasted		
¾	cup buttermilk		

INSTRUCTIONS

1. Insert the chopping blade into the work bowl of the food processor. Put the flours, sugar, baking powder, baking soda, and salt into the work bowl and run on Low to fully mix, about 20 seconds. Add the toasted walnuts and pulse to roughly chop, about 2 to 3 pulses.
2. Put the buttermilk and egg in a liquid measuring cup and mix to fully combine. Reserve.
3. Add the butter to the dry ingredients and pulse until mixture is shaggy. While still pulsing, slowly add the liquid ingredients, until just combined; do not over-mix.
4. Pour the mixture onto a clean counter/large cutting board. Add the dried apple pieces and crumble the blue cheese over the mixture. Gently fold the dough over a few times to combine. Form the dough into a 10-inch cylinder. Using a sharp knife, cut into 8 even rounds. Place on a parchment-lined baking sheet. Cover lightly and transfer to a refrigerator to chill for a minimum of 1 hour, up to overnight.
5. Once chilled, preheat oven to 400°F with the rack in the middle position. Brush each scone with egg wash.
6. Bake in preheated oven for about 25 to 30 minutes, or until golden brown. Remove from oven and allow to cool slightly on the baking sheet. Serve warm or at room temperature.

Nutritional information per scone:

Calories 293 (40% from fat) • carb. 37g • pro. 7g • fat 13g • sat. fat 7g • chol. 50g • sod. 481g • calc. 77mg • fiber 1g

Cheddar-Chive Biscuits

These biscuits have a deeply golden and audibly crackly exterior that is reminiscent of biting into a salty, buttery cheese wafer that dissolves in your mouth. Onion-y chives cut the richness of the Cheddar, making these utterly addictive.

Yield: 8 biscuits

INGREDIENTS

4	ounces good quality Cheddar cheese, preferably extra sharp	½	teaspoon freshly ground black pepper
2	cups all-purpose flour, plus more for shaping the biscuits	12	tablespoons (1½ sticks) very cold unsalted butter, cut into ½-inch cubes, divided
2	tablespoons yellow cornmeal	6	tablespoons (about ½ ounce) roughly chopped chives
1½	teaspoons granulated sugar		
2½	teaspoons baking powder	¾	cup whole buttermilk, well shaken
1¾	teaspoons kosher salt		Flake sea salt, for finishing (optional)

INSTRUCTIONS

1. Insert the fine shredding disc into the work bowl of the food processor. Shred the Cheddar on Low. Reserve.
2. Insert the chopping blade into the work bowl of the food processor. Add the flour, cornmeal, sugar, baking powder, salt, and pepper and process on Low for 10 seconds to sift. Add 10 tablespoons of the cold, cubed butter and pulse just until the mixture starts to resemble coarse crumbs with pea-size bits of butter strewn throughout. Add the reserved shredded Cheddar and chives and pulse 4 to 5 times to incorporate. Add the buttermilk and pulse a few times more to form a shaggy dough.
3. Turn the dough out onto a lightly floured surface. With floured hands, pat the dough into an 8 x 4-inch rectangle. Fold the dough in thirds, as you would a letter: start with a short end and fold a third of the dough down over the center, then fold the other third up to overlap. Turn the dough a quarter clockwise and pat into another 8 x 4-inch rectangle. Fold in thirds a second time. (The folding process builds structure for tall biscuits with lots of flaky layers.) Turn the dough a quarter clockwise again and pat into a final 8 x 4-inch rectangle, about 1 inch thick. Square the sides as best you can with your hands or a bench scraper.
4. Use a sharp knife to cut the rectangle into eight 2-inch squares (a 4 x 2 grid). Space out the biscuits onto a parchment-lined baking sheet and place in the freezer for 30 minutes to chill.
5. While the dough is chilling, set an oven rack in the middle position and preheat the oven to 425°F. Melt the remaining 2 tablespoons of butter.
6. Brush the tops of the chilled biscuits with melted butter and sprinkle with flake sea salt, if desired. Bake in the preheated oven until the tops are deeply golden brown, 20 to 22 minutes. Remove from oven and allow to cool slightly on the baking sheet. Serve warm or at room temperature.

Nutritional information per biscuit:

Calories 343 (58% from fat) • carb. 27g • pro. 9g • fat 22g • sat. fat 14g • chol. 60mg • sod. 487mg calc. 946mg • fiber 2g

Banana Nut Muffins

These simple and flavor-packed muffins freeze very well. Wrap individually and then pull them out of the freezer to make those mid-week breakfasts easier.

Yield: 12 muffins

INGREDIENTS

	Nonstick cooking spray	2	large ripe bananas, each cut into 3 pieces
Muffin batter:			
2	cups unbleached, all-purpose flour	1/3	cup packed light brown sugar
1	teaspoon baking powder	1/3	cup granulated sugar
1/4	teaspoon baking soda	3/4	cup buttermilk
1/2	teaspoon fine sea salt	1/2	cup vegetable oil
1/2	teaspoon ground cinnamon	1	large egg, lightly beaten
		1/2	cup pecans, toasted

INSTRUCTIONS

1. Preheat oven to 350°F with the rack in the middle position. Lightly coat a twelve-cup muffin pan with the cooking spray; reserve.
2. Insert the chopping blade into the work bowl of the food processor. Add the flour, baking powder and soda, salt, and cinnamon and process on Low to sift, about 30 seconds. Remove and reserve in a separate bowl.
3. Put the bananas, sugars, buttermilk, oil, and egg into the work bowl, still fitted with the chopping blade, and process on Low to combine. Add the reserved dry ingredients and nuts and process on Mix until just combined, about 10 seconds.
4. Divide the batter evenly among the prepared muffin cups.
5. Bake in the preheated oven for 18 to 20 minutes, or until a cake tester comes out clean. Let muffins cool in pan for 5 minutes, then turn onto a wire rack to cool completely.

Nutritional information per muffin:

Calories 178 (17% from fat) • carb. 35g • pro. 3g • fat 3g • sat. fat 0g • chol. 16mg • sod. 130mg • calc. 11mg • fiber 1g

Mushroom and Kale Quiche

Quiche is surprisingly simple to prepare, and made even simpler with the assistance of the food processor. Be sure the crust is nicely par-baked before pouring in the filling to ensure a flaky base.

Yield: 12 servings

INGREDIENTS

½	recipe Pâte Brisée (page 60)	¼	teaspoon kosher salt, divided
1	large egg white, lightly beaten		Pinch freshly ground black pepper
1	garlic clove, peeled	¼	teaspoon fresh thyme leaves
4	large lacinato kale stems, tough stems removed	1	ounce Gruyère or Swiss cheese
4	ounces baby bella (cremini) or white mushrooms, scrubbed and trimmed	½	cup whole milk
		½	cup heavy cream
1½	teaspoons olive oil	4	large eggs

INSTRUCTIONS

1. On a lightly floured surface, roll out the pastry into an 11-inch circle that is about ⅛ inch thick. Reverse the dough onto the rolling pin and unroll it evenly over a 9-inch tart pan. Press the dough lightly into the pan, lifting the edges and working it gently down into the bottom edge of the pan. Trim off excess dough by rolling the pin over the top of the pan. With your thumbs, push the dough ⅛ inch above the edge of the mold, to make an even, rounded rim of dough around the inside circumference of the pan. Chill in refrigerator for about 30 minutes.
2. Preheat oven to 400°F with the rack in the middle position. Using the tines of a fork, prick the dough evenly all over, but make sure not to go entirely through the dough. Line the shell with parchment and weigh it down with pie weights, dried beans, or rice. Put the tart shell in the oven and bake until the dough under the parchment is no longer wet, about 20 minutes. Remove the beans/rice and parchment and continue baking for another 2 minutes, until the shell is lightly brown. Brush with egg white immediately. Reserve.
3. While the tart shell is baking, prepare the filling. Insert the chopping blade into the work bowl of the food processor. With the machine running on High, drop the garlic through the feed tube to finely chop. Keeping the garlic in the work bowl, remove the chopping blade (set aside – it will be used again) and insert the slicing disc at setting 4. Roll the kale leaves together and slice. Then slice the mushrooms, at the same setting.
4. Put the oil into a medium skillet (about 10 inches) set over medium-low heat. Once oil is hot, add the garlic with a pinch of the salt and the pepper. Sauté until softened and fragrant, but has picked up no color. Add the sliced kale and mushrooms, remaining salt, and the thyme. Sauté until the kale is bright and wilted and the mushrooms are starting to brown and softened. Remove and reserve.
5. Remove the slicing disc and replace with the fine shredding disc. Shred the Gruyère on Low. Remove and reserve.
6. Remove the shredding disc and replace with the chopping blade. Process the milk, cream, and eggs on Low until combined, about 20 seconds. Reserve custard in bowl.
7. Spread the kale/mushroom mixture in the tart shell, pour in custard and sprinkle cheese on top. (Depending on your tart/pie pan, all of the custard may or may not fit. Do not overfill.)
8. Carefully place the quiche in the preheated oven. Bake until just set, about 20 minutes.
9. Allow to cool for about 5 minutes before slicing and serving.

Nutritional information per serving:

Calories 181 (70% from fat) • carb. 9g • pro. 4g • fat 14g
sat. fat 9g • chol. 99mg • sod. 180mg • calc. 46mg • fiber 0g

Maple Breakfast Sausage

Ditch the store-bought version for this homemade preparation that is considerably fresher and higher quality. Shape and freeze patties ahead of time so brunch is easy like Sunday morning.

Yield: 8 patties

INGREDIENTS

1	pound boneless pork shoulder (Boston butt), cut into ½-inch pieces	½	teaspoon finely grated ginger
2	ounces pork belly or fatback, cut into ½-inch pieces	1	teaspoon fennel seeds, toasted
1	tablespoon, plus 2 teaspoons pure maple syrup	2	teaspoons kosher salt
1	tablespoon, plus 1 teaspoon finely chopped fresh sage leaves	¼	teaspoon freshly ground black pepper
1	tablespoon finely chopped fresh thyme leaves	⅛	teaspoon ground white pepper
		½	teaspoon red pepper flakes
		⅛	teaspoon cayenne
			Pinch freshly ground nutmeg (optional)
		2	tablespoons ice water

INSTRUCTIONS

1. Spread pork shoulder and belly into a single layer on a parchment-lined baking sheet and transfer to the freezer until the pieces are firm but not completely frozen, about 15 to 20 minutes.
2. Insert the chopping blade into the work bowl of the food processor. Add the partially frozen meat and pulse to chop, about 10 long pulses, pausing between each pulse for meat to drop to the blade, until coarsely chopped. Scrape the bowl halfway through pulsing.
3. Add the remaining ingredients and pulse until incorporated and the meat is finely chopped, about 6 long pulses, or until it holds when pinched together. The mixture should look homogenous but not paste-like. Scrape into a medium mixing bowl. Press plastic wrap directly on the surface of the meat and refrigerate for at least 30 minutes and up to 24 hours.
4. When ready to cook the sausage, form mixture into 8 patties (about 2¼ ounces each), ¼-inch thick. Griddle patties in a cast-iron pan over medium-high heat until browned, about 2 minutes per side. Drain on a paper towel-lined plate. Serve hot.

Nutritional information per patty:

Calories 203 (65% from fat) • carb. 3g • pro. 14g • fat 15g • sat. fat 5g • chol. 54mg • sod. 326mg calc. 26mg • fiber 0g

Zucchini Chocolate-Chip Bread

This moist, quick bread is perfect for breakfast or for an afternoon snack. The chocolate chips are a nice treat, but if a healthier bread is desired, they can be substituted with additional nuts or dried fruit.

Yield: one 2-pound loaf (16 servings)

INGREDIENTS

	Nonstick cooking spray	1	large zucchini, approximately 8 to 10 ounces
1¾	cups unbleached, all-purpose flour		
1½	teaspoons ground cinnamon	½	cup vegetable oil
¾	teaspoon ground allspice	1	cup granulated sugar
¼	teaspoon ground nutmeg	2	large eggs
1	teaspoon fine sea salt	½	cup chocolate chips (or use dried cranberries or cherries for a less-sweet flavor)
1½	teaspoons baking powder		
½	cup walnuts, lightly toasted		

INSTRUCTIONS

1. Preheat oven to 350°F. Coat a 9 x 5 x 3-inch loaf pan with cooking spray.
2. Insert the chopping blade into the work bowl of the food processor. Add the flour, spices, salt, and baking powder and process on Low for 10 seconds to sift. Transfer ingredients to a large bowl; reserve. Add the walnuts to the work bowl and chop, 2 to 3 pulses. Leaving the nuts in the work bowl, remove the chopping blade and insert the medium shredding disc. Trim the zucchini to fit the feed tube and shred. Transfer the walnuts and zucchini to the bowl with the dry ingredients. Stir to mix.
3. Reinsert the chopping blade and add the vegetable oil, sugar, and eggs. Process on Low for 5 to 10 seconds until combined. Add wet ingredients to the mixing bowl with the dry ingredients, along with the chocolate chips or dried fruit, and stir until just combined.
4. Pour the batter into the prepared pan and bake in the middle of the oven for 1 hour and 15 minutes, or until a toothpick or cake tester comes out clean.
5. Cool on a wire rack for 5 minutes, and then turn the loaf out onto a wire rack to cool completely.

Nutritional information per serving:

Calories 194 (37% from fat) • carb. 28g • pro. 3g • fat 8g • sat. fat 1g • chol. 23mg • sod. 183mg • calc. 14mg • fiber 1g

Energy Protein Bites

These are a great pick-me-up in the afternoon, or just what you may need to get yourself going to get your day started.

Yield: about 4 dozen

INGREDIENTS

2/3	cup unsalted mixed nuts (or can use just one type of nut. Softer ones, like cashews, work particularly well)	2	tablespoons maple syrup
		2 to 4	tablespoons water
1/2	cup pitted dates	2	tablespoons sunflower seeds
1	cup rolled oats	2	tablespoons chia seeds
1	tablespoon cocoa powder	1/4	cup mini chocolate chips
1/2	teaspoon fine sea salt	2/3	cup finely shredded coconut, for rolling
1	cup unsalted peanut butter, preferably creamy		

INSTRUCTIONS

1. Insert the chopping blade into the work bowl of the food processor. Add the nuts and dates and pulse to roughly chop, about 12 to 13 long pulses. Add the oats, cocoa powder, salt, peanut butter, syrup, and 2 tablespoons of water. Process on Low until the mixture comes together into a cohesive mixture, about 30 to 40 seconds, and then run on High until the mixture is mostly smooth, an additional 30 to 40 seconds. Stop the unit to scrape down as needed, and add additional water, 1 tablespoon at a time, if the mixture seems too dry.
2. Add the sunflower seeds, chia seeds, and chips and pulse to combine. The entire mixture should be slightly sticky, but should hold together when squeezed between two fingers.
3. Scoop the mixture into about 1 1/2-tablespoon rounds. Put the shredded coconut into a shallow dish or pie plate. Roll the rounds in the shredded coconut and then transfer to a parchment-lined tray and refrigerate until firm, a minimum of 30 minutes.

Nutritional information per serving (1 round):

Calories 194 (37% from fat) • carb. 28g • pro. 3g • fat 8g • sat. fat 1g • chol. 23mg • sod. 183mg • calc. 14mg • fiber 1g

Acai Smoothie Bowls

Skip the trip to the smoothie bar and make this trendy treat at home.

Yield: 2 servings

INGREDIENTS

1	medium to large, peeled ripe banana, cut into 1/2-inch coins	2	tablespoons nut or seed butter
			Dash of cinnamon (optional)
2	frozen packets unsweetened acai pulp, broken up	2/3	cup apple juice (preferably unfiltered)
1	cup frozen mixed berries or wild blueberries		

Toppings:
Sliced banana, fresh berries, chia seeds, cacao nibs, granola, sliced almonds

INSTRUCTIONS

1. Insert the chopping blade into the work bowl of the food processor. Put the banana, acai, berries, nut/seed butter, and cinnamon, if using, and pulse to break up frozen fruit, about 3 times. With the

machine running on Low, slowly pour the apple juice through the feed tube. Continue to process until thick and smooth, about 45 seconds.

2. Divide the mixture between two serving bowls and top with toppings of choice. (**Tip:** Chill serving bowls ahead of time to keep the thick, frozen consistency from going soupy.)
3. Serve immediately.

Nutritional information per smoothie bowl (based on 2 servings without toppings):

Calories 293 (39% from fat) • carb. 42g • pro. 5g • fat 13g • sat. fat 2g • chol. 0mg • sod. 33mg
calc. 83mg • fiber 10g

Sweet Almond Chocolate Rolls

These are definitely a breakfast indulgence, but worth the time and effort.

Yield: 8 rolls

INGREDIENTS

1	recipe Yeasted Sweet Dough (page 57)	<u>Sugar Glaze</u>	
1	recipe Almond Paste (page 51), room temperature	1	cup confectioners' sugar, sifted
4	ounces chopped bittersweet or semi- sweet chocolate	2 to 3	tablespoons milk (any fat variety)
	Egg wash (1 large egg plus 1 teaspoon water, whisked well)	¼	teaspoon pure vanilla extract
			Sliced/slivered almonds, lightly toasted, for sprinkling on top

INSTRUCTIONS

1. Roll the dough out to a 16 x 12-inch rectangle. Cover loosely with plastic wrap. Allow to rest for 10 minutes.
2. While the dough is resting, put the almond paste on a piece of parchment paper and roll out to a rectangle about the same size of the dough (it is OK if it is smaller. It does not need to be perfect). Place the almond paste on top of the dough rectangle, keeping borders as even as possible. Sprinkle the chopped chocolate evenly on top of the almond paste and dough.
3. Brush with the egg wash on the exposed dough border. Roll up the dough, in a jelly roll fashion, starting with the long end closest to you. Roll away from you and make the seam to be the bottom of the roll. Press to seal. Cut into 8 pieces, cutting about every 2 inches, to make 8 even rolls. Transfer to a parchment-lined baking pan and cover loosely with plastic wrap. Allow to rest for 20 to 30 minutes.
4. While the rolls are resting, preheat oven to 350°F with the rack in the middle position. When the rolls have sufficiently rested, uncover and brush the top and sides with the egg wash. Put into the preheated oven and bake until evenly golden, about 20 minutes.
5. While the rolls are baking, prepare the sugar glaze. Put all ingredients into a small mixing bowl and whisk well, ensuring that there are no lumps. Reserve.
6. Remove the rolls from the oven and allow to cool slightly. Once ready to serve brush with the sugar glaze and sprinkle with the almonds. Cool slightly to allow the glaze to set. Serve warm or room temperature.

Nutritional information per roll:

Calories 613 (40% from fat) • carb. 82g • pro. 14g • fat 28g • sat. fat 9g • chol. 67mg • sod. 231mg
calc. 78mg • fiber 5g

Scallion-Miso Butter

This unique-tasting butter is best served over a simple grilled chicken or steak, or melted into a bowl of rice and vegetables.

Yield: about 10 tablespoons (5 ounces)

INGREDIENTS

- | | | | |
|---|---|--------|------------------------|
| 1 | scallion, trimmed and cut into 1-inch pieces | 2 to 3 | tablespoons white miso |
| 8 | tablespoons (1 stick) good quality unsalted butter, cut into 4 pieces, room temperature | | |
-

INSTRUCTIONS

1. Insert the chopping blade into the work bowl of the food processor. With the unit running on High, drop the scallion into the work bowl through the feed tube to finely chop. Add butter and miso and pulse a few times, then process on Low to combine, about 40 seconds, stopping to scrape down as necessary.
2. Form into a log, wrap well, and chill.

Nutritional information per serving (1 tablespoon):

Calories 86 (92% from fat) • carb. 1g • pro. 0g • fat 9g • sat. fat 6g • chol. 24mg • sod. 108mg • calc. 1mg • fiber 0g

Horseradish Shallot Butter

Fresh horseradish is best for this sharp-tasting butter, but if that is unavailable, jarred may be used, just be sure to squeeze out all the liquid.

Yield: about 12 tablespoons (6 ounces)

INGREDIENTS

- | | | | |
|---|--|--------|--|
| 1 | 2-inch piece fresh horseradish, peeled* | 8 | tablespoons (1 stick) unsalted butter, room temperature |
| ½ | small shallot, cut into 1-inch pieces | | |
| 1 | tablespoon fresh Italian (flat-leaf) parsley | 1 to 2 | pinches kosher salt
Pinch freshly ground black pepper |
-

INSTRUCTIONS

1. Insert the fine shredding disc into the work bowl of the food processor. Shred the horseradish. Remove the shredding disc and replace with the chopping blade, leaving the horseradish in the work bowl.
2. Add the shallot and parsley. Process on High until finely chopped.
3. Add the butter, salt, and pepper. Process on Low until completely combined. Taste and adjust seasoning as desired.

***Note:** If using jarred horseradish, start with ¼ cup and squeeze out as much of the liquid as possible. Add this after chopping the shallot and parsley, but before the butter.

Nutritional information per serving (1 tablespoon):

Calories 68 (98% from fat) • carb. 0g • pro. 0g • fat 7g • sat. fat 5g • chol. 20mg • sod. 24mg • calc. 2mg • fiber 0g

Hot Honey and Pimento Cream Cheese

A sweet and spicy flavor to up your cream-cheese game. If a spicier flavor is desired, add the crushed red pepper.

Yield: about 1 cup

INGREDIENTS

8	ounces (1 standard package) cream cheese, cut into 4 pieces, room temperature	4	teaspoons hot honey, plus more to taste
¼	cup pimentos, drained	1	teaspoon crushed red pepper, optional, for extra heat

INSTRUCTIONS

1. Insert the chopping blade into the work bowl of the food processor. Add the cream cheese and process on Low to soften.
2. Add the pimentos, hot honey, and crushed red pepper if using. Pulse to combine. Taste and add more hot honey, if desired.

Nutritional information per serving (2 tablespoons):

Calories 109 (78% from fat) • carb. 4g • pro. 2g • fat 10g • sat. fat 5g • chol. 31mg • sod. 92mg • calc. 28mg • fiber 0g

Mango-Chile Salsa

You can choose to make this a chunky salsa, or more of a traditional, saucier salsa depending on how many times you pulse the mixture. Start with just half a chile for a mild spice, and then add more, based on personal preference.

Yield: about 5 cups

INGREDIENTS

½ to 1	serrano chile, seeded and cut into 1-inch pieces	2	medium to large mangoes (1¼ pounds), peeled, pitted and cut into 1-inch pieces (about 4 cups cut)
1	garlic clove	1	cup grape tomatoes
¼	medium red onion, cut into 1-inch pieces	½	teaspoon kosher salt
¼	cup cilantro, leaves and tender stems	1	teaspoon fresh lime juice
½	pound (about 4 to 5 small to medium) tomatillos		honey or granulated sugar, optional

INSTRUCTIONS

1. Insert the chopping blade into the work bowl. With the machine running on High, drop the chile and garlic in through the feed tube and process until finely chopped. Add the onion, cilantro, tomatillos, mangoes, and tomatoes and process, in long pulses, until finely chopped, about 12 to 14 pulses. Add the salt and lime juice and pulse to mix.
2. Add additional pulses based on textural preference. Taste and adjust seasoning as desired. If mangoes are particularly tart, add a bit of honey or granulated sugar to sweeten and balance the heat.

Nutritional information per serving (¼ cup):

Calories 18 (9% from fat) • carb. 4g • pro. 0g • fat 0g • sat. fat 0g • chol. 0mg • sod. 58mg • calc. 5mg • fiber 1g

Harissa

Harissa is a popular North African spicy condiment that is usually paired with meats and vegetables alike. This is not a truly traditional recipe, since we added some sweet, roasted red peppers to tame the heat, but we love it all the same! Try as a topping for our falafel recipe (page 39).

Yield: about 2 cups

INGREDIENTS

3 to 4	ounces dried chiles of your choice (soaked in boiling water for 30 to 40 minutes. See the instructions in step 1)	1	teaspoon kosher salt, or to taste
		¼	cup roasted red peppers, preferably fire roasted
1	teaspoon caraway seeds	1	teaspoon lemon juice
1	teaspoon coriander seeds	¼	cup extra virgin olive oil, plus more for storing
1	teaspoon cumin seeds		
2	garlic cloves, peeled		

INSTRUCTIONS

1. Put the dried chiles into a heatproof bowl and cover with boiling water. Allow to sit for 30 to 40 minutes, or until very soft.
2. While the chiles are soaking, toast the spices. Put the caraway, coriander, and cumin seeds into a small skillet and set over medium-low heat, stirring constantly. These will toast very quickly, so do not walk away. Remove from heat once they are just fragrant (if they get too dark, they will taste bitter).
3. Once the chiles have sufficiently soaked, drain and then remove the stems and seeds (this is best done while wearing gloves to prevent the spicy oils from getting into your hands).
4. Insert the chopping blade into the work bowl of the food processor. Add the seeded chiles and toasted spices, along with the garlic, salt, roasted peppers, and lemon juice. Pulse a few times to break up and then process on High to blend. While the unit is running, add the olive oil through the drizzle hole in the food pusher and continue to process until very smooth, stopping to scrape down the sides of the bowl as necessary. If a thinner consistency is desired, add additional olive oil or water to the mixture.
5. Transfer to a jar and be sure to top with a little olive oil to help preserve the sauce. Harissa can be stored in the refrigerator for up to one month, as long as there is oil on top of the sauce.

Nutritional information per serving (2 tablespoons):

Calories 57 (58% from fat) • carb. 5g • pro. 1g • fat 3g • sat. fat 1g • chol. 0mg • sod. 78mg • calc. 14mg • fiber 0g

Lemon-Dill Hummus

Serve this brightly flavored dip with warm pita for a satisfying snack.

Yield: about 4 cups

INGREDIENTS

2	cans (15½ ounces each) chickpeas, rinsed and drained	2	garlic cloves, peeled
		1½	teaspoons kosher salt
¼	cup tahini	½	teaspoon ground cumin
½	cup cold water, plus more as needed (more will be necessary if the tahini being used is on the thicker side)	1	Pinch freshly ground black pepper
			sprig fresh dill
⅓	cup fresh lemon juice		Extra virgin olive oil, for serving

INSTRUCTIONS

1. Insert the chopping blade into the work bowl of the food processor. Process all the ingredients, except for the dill, on High, until smooth and creamy, about 2 minutes. Add additional water through the feed tube, as needed, until desired consistency has been achieved. Add the dill and pulse to combine.
2. Taste and adjust seasoning as desired. Drizzle with olive oil prior to serving.

Nutritional information per serving (2 tablespoons):

Calories 44 (24% from fat) • carb. 7g • pro. 2g • fat 1g • sat. fat 0g • chol. 0mg • sod. 191mg • calc. 18mg • fiber 1g

Muhammara

Serve this traditional Middle Eastern roasted pepper and walnut spread with warm pita.

Yield: 2 cups

INGREDIENTS

3	large red bell peppers	1	teaspoon ground cumin
1	ounce store-bought pita bread, torn into small pieces	2	tablespoons Aleppo pepper flakes
		½	teaspoon kosher salt, plus more to taste
1	garlic clove, smashed and peeled		
1	cup walnuts, lightly toasted	2	tablespoons pomegranate molasses, plus more for serving
2	teaspoons fresh lemon juice	⅓	cup extra virgin olive oil

INSTRUCTIONS

1. Set an oven rack in the upper position and preheat the broiler. Place whole peppers on a baking sheet and broil, rotating frequently, until evenly blackened and blistered on all sides. Place peppers in a bowl and cover with plastic wrap. The steam will continue to cook the flesh and help to loosen the skins. Set aside for 10 minutes, or until cool enough to handle.
2. Insert the chopping blade into the work bowl of the food processor. With the machine running on High, drop the garlic through the feed tube to finely chop. Scrape down the sides of the bowl. Add the pita bread to the bowl and pulse 2 to 3 times to break up. Process on High until fine crumbs are achieved.
3. Add the walnuts to the work bowl and pulse 2 to 3 times to roughly chop. Then add the peppers, lemon juice, cumin, Aleppo pepper, salt, and molasses to the work bowl and pulse until finely

chopped. Scrape down the sides of the bowl. With the machine running on Low, add the olive oil through the drizzle hole in the food pusher and continue to pulse process until fairly smooth, allowing some texture to remain. Taste to adjust salt and acid.

4. Transfer to serving bowl. Serve drizzled with additional molasses on top.

Nutritional information per serving (¼ cup):

Calories 174 (70% from fat) • carb. 11g • pro. 2g • fat 14g • sat. fat 2g • chol. 0mg • sod. 90mg • calc. 119mg • fiber 2g

Guacamole

The Mix speed allows you to control the texture of the guacamole. It is gentle enough to make it chunky if only processed for a short time, or can be creamy if allowed to run a bit longer.

Yield: about 4 cups

INGREDIENTS

1	garlic clove, peeled	2	tablespoons fresh cilantro, stems discarded
½	jalapeño, seeded and cut into 1-inch pieces	4	ripe avocados, halved and pitted
½	small onion, peeled and cut into 1-inch pieces	2	tablespoons fresh lime juice
		½	teaspoon kosher salt

INSTRUCTIONS

1. Insert the chopping blade into the work bowl of the food processor. With the machine running, drop the garlic and jalapeño through the feed tube to finely chop. Scrape down the sides of the bowl and add the onion and cilantro and pulse 5 times to chop. Scrape down the sides of the bowl.
2. Scoop out the insides of the avocados, in pieces, directly into the work bowl and add the lime juice and salt. Pulse a few times to break up and then run on Mix until desired consistency is achieved, about 10 seconds.

Nutritional information per serving (2 tablespoons):

Calories 55 (74% from fat) • carb. 3g • pro. 1g • fat 5g • sat. fat 1g • chol. 0mg • sod. 47mg • calc. 5mg • fiber 2g

Mayonnaise

Taste the difference in homemade mayonnaise.

Yield: 1 cup

INGREDIENTS

4	large egg yolks	1	teaspoon fresh lemon juice
¾	teaspoon kosher salt	1	tablespoon water
½	teaspoon Dijon mustard	¾	cup vegetable oil

INSTRUCTIONS

1. Insert the chopping blade into the work bowl of the food processor. Process the egg yolks, salt, mustard, lemon juice, and water on Low until smooth, about 30 seconds. With the food processor still running on Low, add the oil through the drizzle hole in the pusher until all oil is incorporated and the mayonnaise is emulsified and homogeneous.

2. Scrape down sides; taste and adjust seasoning accordingly.

Note: For fresh herb mayonnaise: Process $\frac{1}{3}$ cup firmly packed fresh herbs (e.g., parsley, dill, tarragon, basil, etc.), stems removed, with the yolks before adding the oil. For a bolder-flavored mayonnaise, increase the salt by $\frac{1}{4}$ teaspoon, the Dijon by $\frac{1}{2}$ teaspoon and lemon juice to 1 tablespoon.

Nutritional information per serving (1 tablespoon):

Calories 104 (97% from fat) • carb. 0g • pro. 1g • fat 12g • sat. fat 1g • chol. 46mg • sod. 113mg • calc. 6mg • fiber 0g

Basil Pesto

Once you taste how vibrant homemade pesto is you will never buy it pre-made again.

Yield: about 1 cup

INGREDIENTS

1	ounce Parmesan or Pecorino cheese, cut into $\frac{1}{2}$ -inch cubes	1 to 2	pinches kosher salt
$\frac{1}{4}$	cup pine nuts, lightly toasted		Pinch freshly ground black pepper
1	garlic clove, peeled	$\frac{1}{2}$	cup extra virgin olive oil, plus more as desired
2	cups tightly packed fresh basil leaves		

INSTRUCTIONS

1. Insert the chopping blade into the work bowl of the food processor. Add the cheese, nuts, and garlic and process on High until roughly chopped, about 10 seconds. Add the basil, salt, and pepper; chop using 10 to 15 pulses. With the machine running on Low, add the olive oil in a slow and steady stream through the feed tube, processing until combined and an emulsion is formed, about 1 minute. Scrape down the sides of the work bowl. If a thinner consistency is desired, process with additional oil or water.
2. To store the pesto, transfer to a glass jar or airtight container; tap to remove air bubbles and even out the surface. Cover the surface directly with plastic wrap and refrigerate. The pesto will keep for 5 days in the refrigerator, or it may be frozen for up to 2 months.

Nutritional information per serving (1 tablespoon):

Calories 86 (92% from fat) • carb. 1g • pro. 1g • fat 9g • sat. fat 2g • chol. 2mg • sod. 78mg • calc. 37mg • fiber 0g

Vegan Caesar Dressing

A healthier and vegan-friendly alternative to traditional Caesar dressing. This recipe omits the egg yolks and anchovies and achieves creaminess thanks to the soaked cashews, and the umami flavor thanks to the soy sauce.

Yield: about $\frac{3}{4}$ cup

INGREDIENTS

$\frac{1}{2}$	cup raw cashews, soaked in fresh, cold water overnight	1	garlic clove
$\frac{1}{4}$	cup water, plus more as needed	2	teaspoons capers
1	tablespoon fresh lemon juice	$\frac{1}{2}$	teaspoon freshly ground black pepper
$1\frac{1}{2}$	teaspoons Dijon mustard		Pinch kosher salt, or more to taste
2	teaspoons soy sauce, reduced sodium	2	tablespoons extra virgin olive oil

INSTRUCTIONS

1. Insert the chopping blade into the work bowl of the food processor.
2. Drain and rinse cashews. Put all ingredients, except for the olive oil, into the work bowl and process on Low. While the unit is running, gradually add the oil through the drizzle hole in the food pusher. Once the oil is fully incorporated, switch to High and allow to process for an additional minute, or until very smooth.
3. If the dressing is too thick, add additional water, 1 tablespoon at a time, and continue to process on High.
4. Taste and adjust seasoning if necessary, adding salt if desired.

Nutritional information per serving (1 tablespoon):

Calories 55 (78% from fat) • carb. 2g • pro. 1g • fat 5g • sat. fat 1g • chol. 0mg • sod. 59mg • calc. 4mg • fiber 0g

Lemon Vinaigrette

This can very easily be your go-to salad dressing for a bowl full of fresh greens and veggies.

Yield: about 1 cup

INGREDIENTS

1	garlic clove, peeled	¾	teaspoon kosher salt
	Zest of 1 lemon, grated	¼	teaspoon freshly ground black pepper
¼	cup fresh lemon juice	¾	cup extra virgin olive oil
2	teaspoons Dijon mustard		

INSTRUCTIONS

1. Fit the chopping blade into the work bowl of the food processor. With the unit running on High, drop the garlic through the feed tube. Stop and scrape down the sides of the bowl. Add the lemon zest and juice, Dijon, salt, and pepper. Process on High to fully mix.
2. With the unit running on Low, gradually add the olive oil through the drizzle hole of the food pusher. Once all the oil is added, allow to mix an additional 30 to 60 seconds to fully emulsify.
3. Taste and adjust seasoning as desired.

Nutritional information per serving (1 tablespoon):

Calories 90 (99% from fat) • carb. 0g • pro. 0g • fat 10g • sat. fat 2g • chol. 0mg • sod. 68mg • calc. 3mg • fiber 0g

Ranch Dressing

A classic for a reason, this is a very versatile dressing that can be served over a simple salad, or one more complex like our Chopped Salad on page 40. Leftover dressing can also be spread onto a fried or grilled chicken sandwich.

Yield: about 1²/₃ cups

INGREDIENTS

1	garlic clove, peeled	½	cup sour cream
6	chives, cut into 1-inch pieces	1½	teaspoon fresh lemon juice
1	sprig fresh dill, tough stem trimmed and cut into 1-inch pieces	½	teaspoon onion powder
1	tablespoon fresh Italian (flat-leaf) parsley leaves	1	teaspoon kosher salt
		½	teaspoon freshly ground black pepper
			Pinch of cayenne pepper
½	cup buttermilk		
½	cup mayonnaise		

INSTRUCTIONS

1. Fit the chopping blade into the work bowl of the food processor. With the unit running on High, drop the garlic through the feed tube. Stop and scrape down the sides of the bowl. Add the herbs and pulse to finely chop. Add the remaining ingredients and process on High to fully mix.
2. Taste and adjust seasoning as desired.

Nutritional information per serving:

Calories 43 (92% from fat) • carb. 1g • pro. 0g • fat 4g • sat. fat 1g • chol. 6mg • sod. 116mg • calc. 10mg • fiber 0g

Radish Raita

The yogurt in this Indian condiment acts as a cooling agent to dial down spicy dishes. The addition of radish and mint make for a refreshing side, perfect to serve with Chicken Tikka Skewers (page 33).

Yield: 1½ cups

INGREDIENTS

5	ounces (about 6) red radishes, trimmed	¼	teaspoon granulated sugar
1	small (about ¾ ounce) shallot, cut into 1-inch pieces	1	tablespoon lime juice
½	serrano or jalapeño, seeded (optional) and cut into 1-inch pieces	½	teaspoon kosher salt
1	cup plain whole Greek-style yogurt	2	teaspoons ghee or neutral oil, such as grapeseed or sunflower seed oil
2	tablespoons finely chopped mint, plus a few small whole leaves for serving	½	teaspoon cumin seeds
		¼	teaspoon coriander seeds
		¼	teaspoon black mustard seeds

INSTRUCTIONS

1. Insert the medium shredding disc into the work bowl of the food processor. Shred radishes. Transfer to a dish towel and squeeze out extra moisture. Reserve.
2. Remove the shredding disc and insert the chopping blade. With the machine running on High, drop the shallot and serrano through the feed tube to finely chop. Scrape down the sides of the work bowl. Add the yogurt, shredded radish, mint, sugar, lime juice, and salt and pulse until combined. Taste and adjust for salt.
3. Just before serving, melt the ghee in a small skillet over medium-low heat. Carefully add the cumin seeds, coriander seeds, and mustard seeds and cook for 30 seconds, or until first seeds start to sputter and pop. Remove from heat to cool slightly.
4. Transfer raita to a serving bowl. Drizzle ghee and seeds over and top with mint leaves. Serve immediately.

Nutritional information per serving (¼ cup):

Calories 62 (53% from fat) • carb. 3g • pro. 4g • fat 4g • sat. fat 2g • chol. 5mg • sod. 112mg • calc. 50mg • fiber 1g

Tzatziki

The Greek cousin of raita, this sauce benefits from time in the refrigerator so the flavors can develop. For a thicker consistency, drain the yogurt in the refrigerator overnight before proceeding to step 2.

Yield: 1¾ cups

INGREDIENTS

2	cups whole milk plain yogurt	¼	teaspoon lemon zest
8	ounces English (seedless) cucumber		Large pinch kosher salt
2	garlic cloves, peeled	1	tablespoon finely chopped fresh dill
1	tablespoon fresh lemon juice		

INSTRUCTIONS

1. Line a fine mesh strainer with 1 to 2 paper coffee filters and position it over a bowl. Fill the paper-lined strainer with the yogurt and drain for 1 hour.

2. While the yogurt is draining, insert the fine shredding disc into the work bowl of the food processor. Shred the cucumber. Remove and press through a fine mesh strainer to remove as much moisture as possible (this can also be achieved by putting the shredded cucumber into a flour sack towel and squeezing well over a bowl). Discard the liquid and transfer the squeezed cucumber to a mixing bowl.
3. Remove the shredding disc and replace with the chopping blade. While running on High, drop the garlic through the feed tube and process until finely chopped. Add to the bowl with the cucumber. Add the remaining ingredients, including the strained yogurt. Stir to combine and chill in refrigerator until ready to serve. Taste and adjust seasoning as desired.

Nutritional information per serving (2 tablespoons):

Calories 32 (32% from fat) • carb. 3g • pro. 2g • fat 1g • sat. fat 1g • chol. 5mg • sod. 70mg • calc. 71mg • fiber 0g

Zhug

This zingy green sauce from Yemen packs a punch of flavor and heat. Dab it on just about anything and simply a must atop falafel (page 39).

Yield: about 1 cup

INGREDIENTS

1	cup cilantro leaves and tender stems, loosely packed	¼	teaspoon ground cardamom
1	cup parsley leaves, loosely packed	¼	teaspoon granulated sugar
2	garlic cloves, smashed and peeled	½	teaspoon kosher salt
4	serrano or Thai bird chiles, stemmed and cut into 1-inch pieces	¼	teaspoon freshly ground black pepper
½	teaspoons ground coriander	½	cup olive oil, plus more to finish
½	teaspoon ground cumin	1 to 2	teaspoons fresh lemon juice, to taste (optional)

INSTRUCTIONS

1. Insert the chopping blade into the work bowl of the food processor. Put the cilantro, parsley, garlic, chiles, coriander, cumin, cardamom, sugar, salt and pepper into the work bowl and pulse about 10 to 15 times until very finely chopped. Scrape down the sides of the work bowl. With the machine running on Low, add the olive oil through drizzle hole in the food pusher until incorporated.
2. Taste and adjust salt and acid, adding lemon juice to brighten as needed. Let stand 10 minutes before serving.

Nutritional information per serving (2 tablespoons):

Calories 125 (96% from fat) • carb. 1g • pro. 0g • fat 14g • sat. fat 2g • chol. 0mg • sod. 75mg • calc. 30mg • fiber 0g

Loaded Burrito Bowl

From the ground beef to the guacamole and refried beans, the food processor prepares just about every component of this zesty and satisfying deconstructed burrito.

Yield: 6 to 8 servings

INGREDIENTS

½	medium to large red onion	½	teaspoon kosher salt
1 to 2	medium to large bell peppers	1 to 2	pinches freshly ground black pepper
4	ounces mushrooms	1	package (1/4 cup) taco seasoning mix*
4	ounces pepper Jack cheese		Water
2	garlic cloves, peeled		Brown rice, for serving
2	pounds beef stew meat, cut into 2-inch pieces		Refried beans, for serving
1	tablespoon vegetable oil		Guacamole, for serving
			Salsa, for serving

INSTRUCTIONS

1. Insert the slicing disc, set to 4mm, into the work bowl of the food processor. Slice the onion, pepper(s), and mushrooms on High. Remove and reserve.
2. Remove the slicing disc and replace it with the medium shredding disc. Shred the cheese on Low. Remove and reserve in a separate bowl.
3. Remove the shredding disc and replace it with the chopping blade. While the unit is running on Low, drop the garlic cloves through the feed tube to finely chop. Add the meat and pulse until finely chopped, about 15 pulses.
4. Put the vegetable oil into a large skillet set over medium heat. Once the oil is hot, add the vegetables with the salt and pepper, and sauté until softened. Remove and reserve. Increase the heat to high and add the beef. Cook until nicely browned. When fully cooked, add the taco seasoning mix and enough water to make a bit of a sauce (most packages will recommend ⅓ to ⅔ cup water, depending on the mixture). Cook until nicely coated and just simmering. Remove and reserve.
5. Serve the beef, vegetables, cheese, and other suggested topping. We recommend a small scoop of rice per bowl, then topped with the meat, beans, vegetables, and a bit of guacamole and salsa.

***Note:** While the purchased taco seasoning packet is a real time saver, you can prepare your own spice blend if preferred.

Nutritional information per serving (based on 8 servings):

Calories 230 (44% from fat) • carb. 4g • pro. 28g • fat 11g • sat. fat 5g • chol. 85mg • sod. 437mg
calc. 123mg • fiber 1g

Chicken Tikka Skewers

Get summer grilling with our take on the popular Indian-spiced chicken – so juicy and flavorful!

Yield: 4 to 6 servings

INGREDIENTS

Marinade:

1	1½-inch (about ½ ounce) piece of ginger, peeled and cut into ½-inch coins	½	teaspoon ground cumin
3	garlic cloves, smashed and peeled	½	teaspoon smoked paprika
1	serrano or jalapeño, seeded (optional) and cut into 1-inch pieces		Pinch cayenne pepper
1	cup plain Greek-style yogurt	1	teaspoon granulated sugar
1½	teaspoons kosher salt, plus more for skewers	<u>Chicken Skewers:</u>	
1	teaspoon chili powder	1½	pounds skinless, boneless chicken thighs, patted dry, excess fat trimmed and sliced in half, lengthwise
1	teaspoon ground turmeric	6 to 8	12-inch skewers (soaked in water for 30 minutes, if wooden)
2	teaspoons garam masala		Neutral oil, such as canola or grapeseed, for grilling
½	teaspoon ground coriander		Cilantro leaves and lemon wedges, for serving

INSTRUCTIONS

1. Make the marinade. Insert the chopping blade into the work bowl of the food processor. With the machine running on High, drop the ginger, garlic and serrano through the feed tube to finely chop. Scrape down the sides of the bowl. Add the yogurt along with the remaining marinade ingredients and process on Low to fully blend, about 20 seconds.
2. Pour marinade into a large, resealable plastic bag. Add chicken pieces and tightly seal. Use your hands to massage the marinade into chicken. Refrigerate to marinate at least 30 minutes or up to 4 hours.
3. When ready to cook, thread chicken onto skewers, accordion style; let any excess marinade drip off. Sprinkle lightly with salt. Preheat a grill to medium heat and oil grates. Grill, turning occasionally until evenly browned and charred in spots, about 10 to 12 minutes.
4. Transfer skewers to a platter and top with cilantro. Serve with lemon wedges.

Nutritional information per serving (based on 6 servings):

Calories 208 (36% from fat) • carb. 7g • pro. 25g • fat 8g • sat. fat 3g • chol. 110mg • sod. 520mg calc. 71mg • fiber 0g

Basic Pasta Dough

Homemade pasta dough is a breeze to make with the help of your food processor!

Yield: 1½ pounds, 6 to 8 servings for cut pasta

INGREDIENTS

2½	cups “00” flour, plus more for dusting	1½	teaspoons kosher salt
⅔	cup semolina flour	5	large eggs, lightly beaten

INSTRUCTIONS

1. Insert the chopping blade into the work bowl of the food processor. Add the flours and salt to the bowl and process on Low to sift. With the machine running on Low, pour the beaten eggs through the feed tube as fast as the flour absorbs them. Process until the dough cleans the sides of the work bowl and forms a rough mass. Continue to process for 30 seconds to knead the dough. Dough should be tacky, but not wet.
2. Transfer dough to a lightly floured surface and knead by hand for an additional 2 to 3 minutes until smooth and elastic. Wrap in plastic wrap and let rest at room temperature for at least 30 minutes, or in the refrigerator for up to 24 hours.

Nutritional information per serving (3 ounces):

Calories 222 (13% from fat) • carb. 40g • pro. 10g • fat 4g • sat. fat 1g • chol. 116mg • sod. 254mg calc. 19mg • fiber 2g

Butternut Squash Ravioli with Brown Butter and Sage

A dish you can curl up to on a cold autumn night, and at the same time elegant enough for a dinner party.

Yield: about 45 ravioli, 6 to 8 servings as a main dish

INGREDIENTS

6	tablespoons unsalted butter, divided	4	sprigs of fresh thyme
1	small butternut squash (about 2 pounds), peeled, seeded, and cut into ½-inch cubes	⅓	cup walnuts
1	medium shallot, cut into ½-inch pieces	3	ounces Parmesan, cut into ½-inch cubes
3	garlic cloves, unpeeled	¼	cup mascarpone cheese
1	tablespoon extra-virgin olive oil	1	large egg, yolk and white separated, egg white whisked with 1 teaspoon water for sealing ravioli
2	teaspoons packed light brown sugar	¼	teaspoon grated lemon zest (optional)
1½	teaspoons kosher salt, divided, plus more for pasta water and to taste		Pinch freshly ground nutmeg
	Pinch freshly ground black pepper, plus more to taste	1	recipe Basic Pasta Dough (previous recipe)
16	fresh sage leaves, divided		Semolina flour, for dusting

INSTRUCTIONS

1. Preheat oven to 400°F with a rack in the middle position. Melt 2 tablespoons of butter.

2. Put the squash, shallot, and garlic cloves on baking sheet. Add the oil, melted butter, brown sugar, $\frac{3}{4}$ teaspoon salt, pepper, 4 sage leaves, and thyme and toss to coat. Spread into an even layer. Cover loosely with foil. Roast, stirring once or twice, until squash is very tender, about 45 to 50 minutes. Uncover and let cool to room temperature.
3. Meanwhile, insert the chopping blade into the work bowl of the food processor. Add the walnuts and pulse to finely chop. Remove and reserve. With the unit running on High, drop the Parmesan through the feed tube and process until finely grated. Remove and reserve.
4. Prepare ravioli filling. Peel garlic cloves; discard skin and herbs. Put garlic, shallot, and about half the squash into the work bowl along with $\frac{1}{4}$ cup of the reserved Parmesan, mascarpone, egg yolk, zest and nutmeg and remaining $\frac{3}{4}$ teaspoon salt. Process on High until smooth, about 45 seconds, stopping to scrape down the sides of the bowl. Add remaining squash and pulse to combine. Reserve.
5. Use a pasta maker to roll and cut the pasta dough to ravioli thickness. Alternatively, roll the dough out by hand with a rolling pin. Cut the dough into 6 equal pieces. Working with one piece at a time (keeping the rest of the dough covered), lightly flour both sides and roll lengthwise on a clean surface until you have a rectangle that is approximately 20 inches long by 6 inches wide. You should be able to see your hands through the pasta when you lift it. Transfer sheets to a semolina-dusted baking sheet and cover loosely with plastic wrap until ready to fill.
6. Fill the ravioli. Place one sheet on a work surface lightly dusted with semolina. Determine the midway point of the sheet and brush the length of one half with egg wash. Starting 1-inch from the short edge, spoon mounds of filling, about 1 tablespoon each, down the center length of the egg-washed half, spacing at least $1\frac{1}{2}$ inches apart. Fold the dry half of the sheet directly over the filled side. Press firmly in a circle around the mounds of filling to adhere, removing any air pockets with fingers. Use a pastry wheel or ravioli stamp to cut ravioli out evenly around the filling. Transfer ravioli to a semolina-dusted baking sheet and cover loosely with plastic wrap until ready to cook. Continue with remaining pasta sheets and filling.
7. Bring a large pot of salted water to a boil. In a large skillet, melt the remaining 4 tablespoons butter over medium-low heat. Continue to cook, swirling often, until foaming subsides and milk solids turn golden brown and smell nutty, about 3 to 4 minutes. Add the remaining sage leaves and remove from heat. In two batches, add ravioli to boiling water and cook until just tender, about 3 to 4 minutes, and transfer to skillet with a slotted spoon. Add $\frac{1}{4}$ cup pasta cooking liquid to the skillet and toss ravioli over medium-high heat, until sauce emulsifies and thickens to coat. Taste and season with salt and pepper, as needed.
8. Divide ravioli and sage leaves among plates. Top with reserved walnuts and Parmesan. Serve immediately.

Nutritional information per serving (based on 8 servings):

Calories 480 (43% from fat) • carb. 55g • pro. 17g • fat 24g • sat. fat 11g • chol. 179mg • sod. 650mg
calc. 242mg • fiber 6g

Black Bean Veggie Burgers

Our favorite veggie burger.

Yield: 6 burgers

INGREDIENTS

Burger Mixture:		
	1/2	chipotle pepper in adobo, chopped, plus 1 teaspoon adobo sauce
1	medium carrot, peeled and cut into 1-inch pieces	1/2 cup water, divided (this is approximate, you may not need the entire amount)
1	small zucchini, cut into 1-inch pieces	1 cup cooked quinoa
2	garlic cloves, smashed and peeled	1/4 cup chopped fresh cilantro
1/2	small onion, peeled and cut into 1-inch pieces	6 slices Cheddar cheese, or preferred cheese (optional)
2	tablespoons olive oil, divided	6 hamburger buns, grilled
1/2	teaspoon kosher salt, divided	Mayonnaise, for buns (optional)
	Pinch freshly ground black pepper	Sliced avocado, lettuce, thinly sliced red onion and tomato, for serving
1	can (15 ounces) black beans, drained and rinsed	

INSTRUCTIONS

1. Insert the chopping blade into the work bowl of the food processor. Add the carrot and zucchini to the work bowl and pulse to roughly chop. Remove and reserve. With the machine running on Low, drop the garlic through the feed tube to finely chop. Scrape down the sides of the bowl. Add the onion and pulse to finely chop.
2. Put the oil in a medium sauté pan set over medium heat. Once hot, add the garlic, onion, 1/4 teaspoon of salt, and the pepper. Sauté until softened and fragrant, about 5 minutes. Add the black beans, chipotle and sauce, and enough water to keep the pan from being dry. Cook until beans are soft enough to be easily mashed, about 10 minutes, adding additional water as needed to prevent the pan from going dry.
3. Once beans are soft, add the remaining salt, quinoa, carrot, and zucchini. Add additional water, about 2 to 3 tablespoons, stir, partially cover and reduce heat to medium-low and cook vegetables until just softened, about 5 minutes. Let cool slightly.
4. Transfer the mixture to the work bowl of the food processor. Add the cilantro and pulse until mixture is blended but not puréed.
5. Form mixture into 1/3-cup patties. Heat remaining oil in a large cast-iron skillet over medium heat. Working in batches, cook patties until dark brown on both sides, about 10 minutes total. Place cheese, if using, over burgers for the last minute to melt.
6. Serve burgers on toasted buns smeared with mayo, if desired, and choice of toppings.

Nutritional information per veggie burger (patty alone – cheese, bun, mayo and toppings are additional calories):

Calories 166 (28% from fat) • carb. 23g • pro. 7g • fat 5g • sat. fat 1g • chol. 0mg • sod. 200mg calc. 130mg • fiber 5g

Classic Meatballs

For melt-in-your-mouth meatballs, look no further. Spaghetti's match made in heaven!

Yield: about 24 meatballs, 4 to 6 servings

INGREDIENTS

¾	pound boneless beef chuck roast, preferably 20 percent fat	½	cup Italian parsley leaves, loosely packed
¾	pound boneless pork shoulder (Boston butt), cut into ½-inch pieces	2	large eggs, lightly beaten
3	ounces Parmesan cheese, cut into ½-inch cubes	1½	teaspoons kosher salt
2	ounces day-old white bread, crusts removed and torn into pieces	¾	teaspoon freshly ground black pepper
1/3	cup buttermilk	1	tablespoon finely chopped fresh basil
3	large garlic cloves, smashed and peeled	2	teaspoons finely chopped fresh oregano
1	small onion, peeled and cut into 1-inch pieces		Extra-virgin olive oil for coating the sheet pan
			Warm tomato sauce, for serving

INSTRUCTIONS

1. Spread pork shoulder and belly into a single layer on a parchment-lined baking sheet and transfer to the freezer until the pieces are firm but not completely frozen, about 15 to 20 minutes.
2. While the meat is freezing, insert the chopping blade into the work bowl of the food processor. With the unit running on High, drop the Parmesan through the feed tube and process until finely grated. Remove and reserve. Add the bread to the bowl and pulse 2 to 3 times to break up. Process on High until fine crumbs are achieved. Remove disc. Transfer bread crumbs to a small bowl, mix with buttermilk to combine. Reserve.
3. With the machine running on High, drop the garlic through the feed tube to finely chop. Then add the onion and parsley and process until finely chop. Scrape down the sides of the bowl. Add the partially frozen meat and pulse until finely chopped, about 14 long pulses, pausing between each pulse for meat to drop to the blade. Scrape the bowl half way through pulsing. Use a spatula to create a well in the meat and add the eggs, ½ cup reserved parmesan, the panade (soaked breadcrumb mixture), salt, pepper, basil, and oregano. Process on Mix until well combined. Transfer to a medium bowl, cover with plastic wrap and refrigerate for at least 1 hour or up to overnight.
4. When ready to cook, lightly coat a rimmed sheet pan with olive oil. Portion mixture using a medium cookie scoop to get 24 meatballs (approximately 2 tablespoons of mixture; 1½ ounces if you have a food scale). Use moistened hands to shape into balls and arrange 1 inch apart on the prepared sheet pan. Cover with plastic and refrigerate for 30 minutes (skip this step if pressed for time, but it helps meatballs to hold their shape in the oven).
5. Fifteen minutes before baking the meatballs, position oven racks to the middle and top of the oven and preheat the oven to 425°F. Bake meatballs on the middle rack for 10 minutes, then set on the top rack and broil for 2 minutes, until golden brown. Let rest for 15 minutes before adding to warm tomato sauce.
6. Serve as a side or over spaghetti topped with parmesan.

Nutritional information per meatball (without tomato sauce):

Calories 86 (59% from fat) • carb. 2g • pro. 7g • fat 6g • sat. fat 2g • chol. 39mg • sod. 185mg • calc. 32mg • fiber 0g

Lamb Meatballs

These Greek-inspired meatballs are terrific on their own, but when paired with homemade pita (page 56) and tzatziki (page 30) they are a complete meal, set to impress.

Yield: 15 meatballs

INGREDIENTS

1	garlic clove, peeled	1	teaspoon kosher salt
¼	cup fresh Italian parsley leaves	½	teaspoon ground cumin
¼	cup fresh mint leaves	¼	teaspoon freshly ground black pepper
1½	pounds lamb shoulder, cut into 1-inch pieces	1	ounce feta, broken into pieces

INSTRUCTIONS

1. Preheat oven to 400°F with the rack in the middle position.
2. Insert the chopping blade into the work bowl of the food processor. With the unit running on High, drop the garlic into processor to finely chop. Add the parsley and mint and process to finely chop. Add the lamb, salt, cumin, and pepper. Using long pulses, process until roughly chopped, about 12 long pulses. Then add the feta, pulse a few times, until evenly dispersed.
3. Form into 15 rounds. Transfer to a parchment- or foil-lined baking sheet. Put into the preheated oven and bake for 18 minutes.
4. Serve with tzatziki and freshly baked pita, or simply with a green salad and rice.

Nutritional information per serving:

Calories 67 (39% from fat) • carb. 0g • pro. 10g • fat 3g • sat. fat 1g • chol. 31mg • sod. 203mg • calc. 17mg • fiber 0g

Falafel

The food processor makes it possible to whip up this Middle Eastern street food staple in your own home! Remember to soak the chickpeas the night before.

Yield: 24 falafel

INGREDIENTS

2	garlic cloves, peeled	2	tablespoons, plus ½ cup unbleached, all-purpose flour, divided
1	small shallot, cut into 1-inch pieces		
1	cup dried chickpeas, soaked overnight, rinsed and drained	½	teaspoon baking soda
		2	tablespoons water
1	teaspoon kosher salt		Vegetable oil, if frying
⅛	teaspoon freshly ground black pepper		Olive oil, if baking*
1	teaspoon ground cumin		Pita, for serving
½	teaspoon ground coriander		Chopped tomatoes, cucumbers, and lettuce, for serving
⅛	teaspoon chili powder		Tahini (optional)
⅔	cup packed fresh Italian parsley – stems and leaves		

INSTRUCTIONS

1. Insert the chopping blade into the work bowl of the food processor. Add the garlic and shallot and pulse to chop, about 5 times. Scrape down the sides of the bowl and pulse another 2 to 3 times. Add the chickpeas, salt, pepper, spices, parsley, and 2 tablespoons of the flour. Pulse 10 to 12 times to coarsely grind the chickpeas. Scrape down the sides of the bowl and then process on Low for 10 to 15 seconds, until finely ground. Reserve ⅓ cup in a separate bowl.
2. Dissolve the baking soda in the water, and with the unit running on Low, pour through the feed tube. Process for 15 to 20 seconds to blend well. Add to bowl with reserved mixture. Stir well to combine.
3. Using a tablespoon, scoop chickpea mixture and shape into 24 balls (you can also make larger falafel using a 2-tablespoon scoop for 12 falafel balls). Place the balls on a tray or plate lined with wax paper and chill in the refrigerator for 30 minutes. Put the remaining ½ cup of flour in a shallow bowl and set aside.
4. Fill a 3-quart saucepan with enough oil to reach ¼-inch depth and place over medium-high heat until an inserted thermometer registers 375°F.* Roll the falafel in the flour, shaking off any excess and drop into the oil. Cook the falafel in batches, no more than 5 at a time, for about 2½ to 3 minutes, turning halfway through, until browned and crisp.
5. Remove to a paper towel-lined sheet tray and repeat with remaining falafel.
6. Serve falafel with sliced pita, veggies and a drizzle of tahini, if desired.

***Note:** If choosing to bake instead: Preheat oven to 400°F. Line a baking sheet with parchment and drizzle with olive oil. Skip the step of coating the falafel in flour and arrange on the parchment. Drizzle with more oil, turning to coat the balls all over. Bake for 20 to 25 minutes, turning halfway through, until browned and crisp.

Nutritional information per serving (1 tablespoon):

Calories 86 (92% from fat) • carb. 1g • pro. 1g • fat 9g • sat. fat 2g • chol. 2mg • sod. 78mg • calc. 37mg • fiber 0g

Pizza with Ricotta and Pesto

Fresh pesto is the perfect ingredient for homemade pizza.

Yield: one 12-inch pizza, 4 servings

INGREDIENTS

1	recipe Pizza Dough (page 58)	½	cup ricotta
	Cornmeal, for dusting baking sheet	2	ounces ricotta salata
1	ounce Parmesan, cut into ½-inch cubes	1/3	cup prepared Basil Pesto (page 27)

INSTRUCTIONS

1. Preheat an oven with the rack in the middle of the oven. If you have a pizza stone or steel, put it on the rack and allow to preheat for 30 minutes while preparing the pizza.
2. Stretch pizza dough to a 12-inch round and put on a cornmeal-dusted baking sheet. Cover with plastic wrap and allow to rest while preparing the toppings.
3. Insert the metal chopping blade into the work bowl of the food processor. With the unit running on High, drop the Parmesan through the feed tube and allow to process until finely grated. Add the ricotta and pulse to combine.
4. Top the pizza dough with the ricotta mixture.
5. Remove the chopping blade and insert the fine slicing disc. Slice the ricotta salata. Evenly place over the ricotta mixture and then dollop the pesto on top of the cheese.
6. Put into the preheated oven, on top of the baking stone/steel if using, and bake until the cheese is bubbly, about 12 minutes.
7. Allow to cool for a few minutes prior to slicing and serving.

Nutritional information per serving:

Calories 360 (50% from fat) • carb. 32g • pro. 14g • fat 20g • sat. fat 5g • chol. 23mg • sod. 576mg
calc. 268mg • fiber 3g

Cauliflower Pizza Crust

Try this cauliflower crust as a gluten-free alternative.

Yield: one 12-inch pizza crust

INGREDIENTS

4	ounces Parmesan, cut into ½-inch pieces	½	teaspoon kosher salt
		¼	teaspoon freshly ground black pepper
1	head (about 1 pound) cauliflower, cut into 1-inch florets	¼	teaspoon onion powder
		¼	teaspoon garlic powder
2	large eggs		

INSTRUCTIONS

1. Preheat oven to 450°F. Line a baking sheet with parchment paper, reserve.
2. Insert the chopping blade into the work bowl of the food processor. Add the Parmesan and process on High to finely chop.
3. Add the cauliflower and pulse to break up, about 5 to 6 pulses, and then process on High until finely chopped.
4. Add the remaining ingredients and process on High to combine fully.

- Transfer ingredients to the prepared baking sheet. Form into a rectangle about ½ inch thick. Bake until golden brown and slightly firm, about 25 minutes. Cool slightly before topping.
- This crust can now be used as a traditional pizza crust. Top with your favorite pizza toppings and return to the hot oven to finish cooking.

Nutritional information per serving:

Calories 90 (52% from fat) • carb. 3g • pro. 8g • fat 6g • sat. fat 3g • chol. 61mg • sod. 418mg • calc. 20mg • fiber 1g

Chopped Salad

This salad is a bit of a classic chopped salad, with some influence from the popular Cobb salad. We love it with our Ranch Dressing on page 29 or a Green Goddess (recipe found on Cuisinart.com).

Yield: 10 cups

INGREDIENTS

- | | | | |
|---|------------------------------------|---|------------------------------|
| 1 | small shallot, peeled and trimmed | 2 | hard-boiled eggs |
| 1 | head romaine, cut to fit feed tube | 1 | cooked chicken breast |
| 1 | endive, trimmed | ⅓ | cup walnuts, toasted |
| 1 | cup cherry or grape tomatoes | 4 | slices cooked bacon, halved |
| 1 | avocado, pitted | ¾ | cup Ranch Dressing (page 29) |

INSTRUCTIONS

- Insert the slicing disc, set to 2mm, into the work bowl of the food processor. Slice the shallot. Adjust the slicing disc to 7mm and slice on High the romaine, endive, tomatoes, avocado, and eggs, in that order. Transfer to a large serving bowl. Slice the chicken breast, again at 7mm on High, and add to the bowl with the other sliced ingredients.
- Remove the slicing disc and replace it with the chopping blade. Add the walnuts and bacon and pulse to roughly chop. Sprinkle both over the other salad ingredients.
- Serve with the Ranch Dressing on the side.

Note: Due to the various consistencies of the ingredients of this salad, it should be served immediately after preparing.

Nutritional information per serving (1 cup with 1 tablespoon dressing):

Calories 176 (61% from fat) • carb. 7g • pro. 11g • fat 12g • sat. fat 3g • chol. 62mg • sod. 231mg • calc. 72mg • fiber 4g

Spicy Cucumber and Avocado Soup

This cold soup is a nice alternative to gazpacho when the days are too hot to turn on the stove. Best of all, it is ready in just minutes!

Yield: about 6 cups

INGREDIENTS

- | | | | |
|---|---|---|-------------------------------------|
| 2 | scallions, trimmed, white and light green parts, cut into 1-inch pieces | 2 | ripe avocados, pitted and quartered |
| 1 | jalapeño, seeded and cut into 1-inch pieces | 2 | teaspoons grated lime zest |
| 2 | seedless cucumbers, peeled and cut into 1-inch pieces | 2 | teaspoons honey |
| ½ | cup packed cilantro | 1 | teaspoon fine sea salt |
| | | 1 | can (13 ounces) coconut milk |
| | | 3 | tablespoons fresh lime juice |
| | | | water, as needed |

INSTRUCTIONS

1. Insert the chopping blade into the work bowl of the food processor. While the unit is running on High, drop the scallions and jalapeño through the feed tube and process until finely chopped.
2. Add the cucumbers, cilantro, avocados, zest, honey, and salt. Pulse to break up and then process on High until no large pieces remain. Add the coconut milk and lime juice and process on High until smooth. If a thinner consistency is desired, add water through the feed tube while processing.
3. Refrigerate to chill. Once sufficiently chilled, taste and adjust seasoning as desired.

Nutritional information per serving (1 cup):

Calories 202 (76% from fat) • carb. 11g • pro. 2g • fat 19g • sat. fat 12g • chol. 0mg • sod. 377mg
calc. 21mg • fiber 4g

Parsnip and Kabocha Squash Purée

A nice alternative to mashed sweet potatoes or butternut squash, this purée is slightly sweet and slightly tangy.

Yield: about 4 cups

INGREDIENTS

1	kabocha squash, about 3 pounds, halved and seeded	1	pepper, divided
1	tablespoon olive oil, divided	1	medium to large parsnip, about 4 ounces, peeled and halved widthwise
½	teaspoon kosher salt, divided	½	teaspoon fresh thyme leaves
2	pinches freshly ground black	¼	teaspoon fresh lemon juice

INSTRUCTIONS

1. Preheat oven to 425°F with the rack in the middle of the oven. Line a baking pan with foil or parchment paper. Rub the inside of each squash half with half tablespoon olive oil and then sprinkle with the salt and pepper. Put cut-side down on the baking pan and roast for 10 minutes.
2. While the squash is roasting, prepare the parsnip. Remove the pan from the oven and add the parsnip. Carefully drizzle with remaining half tablespoon olive oil and sprinkle with a pinch each of the salt and pepper. Return to the oven and allow to roast for an additional 20 minutes, or until both the parsnip and the squash are tender.
3. Remove from oven and allow to cool until the squash can be scooped. Insert the chopping blade into the work bowl of the food processor. Scoop the flesh of the squash and transfer to the work bowl and add the roasted parsnips and thyme leaves and lemon juice.
4. Pulse a few times to break up and then process on High until smooth. Taste and adjust seasoning to taste.

Nutritional information per serving (½ cup):

Calories 94 (17% from fat) • carb. 20g • pro. 2g • fat 2g • sat. fat 0g • chol. 0mg • sod. 149mg • calc. 62mg • fiber 3g

Gingerbread Cookies with Icing

These traditional cutout cookies will be your new go-to recipe for the holidays.

Yield: about 4 dozen cookies

INGREDIENTS

3¾	cups unbleached, all-purpose flour	1	cup packed light brown sugar
1	teaspoon baking powder	1	cup molasses (not blackstrap)
½	teaspoon baking soda	1	large egg, room temperature
½	teaspoon fine sea salt	Royal Icing:	
1½	teaspoons ground cinnamon	4	cups confectioners' sugar, sifted
1	teaspoon ground ginger	1	large egg white, slightly beaten
¾	teaspoon ground cloves	2	tablespoons whole milk
16	tablespoons (2 sticks) unsalted butter, room temperature	1	teaspoon fresh lemon juice

INSTRUCTIONS

1. Insert the chopping blade into the work bowl of the food processor. Add the flour, baking powder, baking soda, salt, and spices. Process on Low to sift, about 30 seconds. Remove and reserve in a separate mixing bowl.
2. Put the butter, sugar, and molasses into the work bowl, still fitted with the chopping blade. Process on Low until very creamy, stopping to scrape down as necessary. While running on Mix, add the egg through the feed tube. Process until combined. Scrape down the sides.
3. Add the dry ingredients and process on Mix until just combined.
4. Remove dough and knead a few times by hand, to be sure all the ingredients are evenly incorporated. Wrap well and chill until firm, about 2 hours. This dough can also be chilled for up to 3 days, or frozen for one month.
5. After the dough has been sufficiently chilled, roll on a lightly floured surface and cut out into desired shapes. Transfer the cutouts to parchment-lined baking sheets and chill.
6. While cookies are chilling, preheat oven to 350°F with the rack in the middle position. Once preheated, bake cookies until set at the edges but not dark brown, about 10 minutes. Cool completely before decorating.
7. While the cookies are cooling, prepare the Royal Icing. Clean the work bowl and the chopping blade. Reinsert the chopping blade into the work bowl and add all the icing ingredients. Process on Low until smooth. Add more milk or confectioners' sugar to achieve the correct consistency (icing should be thin, but be able to hold its shape when piped).
8. When cookies are cool, decorate as desired with the Royal Icing.

Nutritional information per serving (1 cookie with 1 teaspoon icing):

Calories 114 (29% from fat) • carb. 19g • pro. 1g • fat 4g • sat. fat 2g • chol. 14mg • sod. 49mg • calc. 16mg • fiber 0g

Strawberries & Cream Pinwheel Cookies

Freeze-dried fruit is the answer to buttery, crumbly, shortbread-like cookies that are intensely strawberry flavored, no matter the season.

Yield: about 32 cookies

INGREDIENTS

Cream Dough:

$\frac{2}{3}$	cup unbleached, all-purpose flour
$\frac{1}{3}$	cup rice flour
$\frac{1}{3}$	cup granulated sugar
$1\frac{1}{2}$	teaspoons dry milk powder
$\frac{3}{4}$	teaspoon kosher salt
7	tablespoons good quality, very cold unsalted butter (preferably European style), cut into pieces
1	ounce white chocolate chips, melted and slightly cooled
$1\frac{1}{2}$	teaspoons pure vanilla extract

Strawberry Dough:

$\frac{3}{4}$	cup freeze-dried strawberries
$\frac{1}{2}$	cup unbleached, all-purpose flour
$\frac{1}{3}$	cup rice flour
$\frac{1}{3}$	cup granulated sugar
$1\frac{1}{2}$	teaspoons dry milk powder
$\frac{3}{4}$	teaspoon kosher salt
8	tablespoons (1 stick) good quality, very cold unsalted butter (preferably European style), cut into pieces
$\frac{3}{4}$	teaspoon pure vanilla extract
$\frac{1}{2}$	cup white nonpareils or sanding sugar (preferably pink or white), for rolling

INSTRUCTIONS

1. Make the cream dough. Insert the chopping blade into the work bowl of the food processor. Add the flours, sugar, milk powder, if using, and salt and process on Low for 10 seconds to sift. Add the butter and pulse in 3-second long bursts until large clumps form. Add the white chocolate and vanilla extract and continue to pulse until dough comes together into a single mass. Do not overprocess.
2. Scrape dough out onto a piece of parchment. Pat down into an even layer. Cover with another piece of parchment and roll out into a 12 x 8-inch rectangle. Transfer dough (still between parchment) to a baking sheet and cover loosely with plastic wrap. Refrigerate to chill, at least 15 minutes.
3. Make the strawberry dough. Put the freeze-dried strawberries into the work bowl of the food processor. Process on High until finely ground, about 30 seconds. Add the flours, sugar, milk powder, and salt and process on Low for 10 seconds to sift. Add the butter and pulse in 3-second-long bursts until large clumps form. Add the vanilla extract and continue to pulse until dough comes together into a single mass. Do not overprocess.
4. Scrape dough out onto a piece of parchment. Pat down into an even layer. Cover with another piece of parchment and roll out into a 12 x 7-inch rectangle. Remove the cream dough from the refrigerator and peel off the top piece of parchment.
5. Use the parchment to flip the strawberry dough onto the cream dough, centering the short edge to leave a $\frac{1}{2}$ -inch border of cream dough on either long edge. Press a piece of parchment down onto the strawberry dough. Lightly roll over parchment with a rolling pin to press doughs together. Peel off the top piece of parchment.
6. Starting at the closest long edge, use the remaining underside piece of parchment to help roll the dough into a tight, spiraled log. Wrap log in parchment and refrigerate until very firm, at least 3 hours and up to overnight.
7. When ready to bake, set oven racks to upper and lower positions and preheat oven to 375°F. Line two baking sheets with parchment. Sprinkle a clean work surface with sanding sugar or nonpareils. Remove the log from the refrigerator, unwrap and firmly roll in the nonpareils or sugar until evenly coated. Press with your hands to help any loose granules stick.

8. Using a sharp knife, cut a thin slice off each end of the log (this should be just enough to expose the spiral). Cut the log in half, and then cut each in half. Cut each quarter in half to create eighths. Cut each eighth into 4 equal slices to create 32 cookies. Roll the log away from you as you cut to help keep cookies round. Space cookies 1 inch apart on prepared baking sheets.
9. Bake cookies on lower and upper racks until golden around the edges, about 16 to 18 minutes, rotating pans and switching rack positions halfway. Remove and set baking sheets on a wire cooling rack. Leave on baking sheets to cool completely for texture to set properly. (Cookies can be stored in an airtight container at room temperature for up to 5 days.)

Nutritional information per cookie:

Calories 110 (45% from fat) • carb. 14g • pro. 1g • fat 6g • sat. fat 4g • chol. 14mg • sod. 84mg • calc. 6mg • fiber 0g

Chocolate Chunk Cookies

The Mix speed of the food processor is strong enough to mix this heavy cookie dough, but gentle enough to be sure the chunks of chocolate retain their shape in the dough.

Yield: about 4 dozen cookies

INGREDIENTS

2¼	cups unbleached, all-purpose flour	1	cup packed light brown sugar
1	teaspoon baking soda	½	cup granulated sugar
1	teaspoon kosher salt	2	large eggs, room temperature
½	teaspoon espresso powder	1½	teaspoons pure vanilla extract
16	tablespoons (2 sticks) unsalted butter, cut into 1-inch pieces, room temperature	2	cups chopped bittersweet chocolate
			Flaked sea salt, for sprinkling

INSTRUCTIONS

1. Insert the chopping blade into the work bowl of the food processor. Add the flour, baking soda, salt, and espresso powder and process on Low to sift, at least 30 seconds. Transfer to a separate bowl; reserve.
2. Reinsert the chopping blade into the work bowl. Add the butter and sugars and process on Low until creamy, stopping to scrape down as necessary.
3. Combine the eggs and vanilla extract a liquid measuring cup. While processing on Low, add the eggs and vanilla extract, 1 egg at a time, and process until combined. Stop to scrape down. Add the dry ingredients and process on Mix until no flour is visible. Use a spatula to create a well in the dough and add the chopped chocolate and process on Mix until just combined.
4. Scoop the dough into even, golf ball-sized rounds and place on a parchment-lined tray or baking sheet. Wrap well and allow to chill for a minimum of 1 hour, or up to overnight.
5. Preheat oven to 350°F with racks in the lower and upper thirds of the oven. Line two baking sheets with parchment paper.
6. Once the oven has preheated, divide the chilled, portioned dough between the prepared baking sheets and bake until just browned and set at the edges, about 15 minutes. Remove and immediately sprinkle baked cookies with a pinch of flaked sea salt. Allow pans to cool prior to baking remaining dough.

Nutritional information per cookie:

Calories 132 (47% from fat) • carb. 16g • pro. 1g fat 7g • sat. fat 4g • chol. 18mg • sod. 78mg • calc. 1mg • fiber 0g

Salted PB&J Blondies

The right way to make the lunchbox classic may be in blondie form – we'll let you decide.

Yield: 24 blondies

INGREDIENTS

12	tablespoons (1½ sticks) unsalted butter, plus more for the pan	2	large eggs
1	cup natural creamy peanut butter, mixed well	2	teaspoons pure vanilla extract
1½	cups honey roasted peanuts, divided	1½	cups unbleached, all-purpose flour
2	cups packed light brown sugar	½	cup fruit jam or jelly, such as Concord grape, raspberry or strawberry, slightly warmed
¾	teaspoon baking powder		Flake sea salt, for sprinkling
1¾	teaspoons kosher salt		

INSTRUCTIONS

1. Preheat oven to 350°F with a rack in the middle position. Line a 13 x 9-inch pan with foil, making sure to leave some overhang. Grease with butter and reserve.
2. In a medium saucepan, heat the butter over medium-low heat, until just melted. Remove from heat and stir in the peanut butter.
3. Insert the chopping blade into the work bowl of the food processor. Add 1 cup of the peanuts and pulse to roughly chop. Remove and reserve. Add the sugar, baking powder, salt, eggs, and vanilla extract to the work bowl. Process on Low until creamy, scraping down bowl as necessary. With the machine running, add the butter mixture in a steady stream through the feed tube, processing until incorporated. Stop and scrape down the sides of the bowl. Sift in the flour and process on Mix until flour disappears. Carefully remove chopping blade and fold in 1 cup reserved, chopped peanuts.
4. Scrape batter into prepared pan and spread into corners of pan, smoothing into an even layer. Drop the warmed fruit jam by the teaspoon, distributing it over the surface. Draw the tip of a knife through the jam to create swirls. Scatter remaining peanuts over the top and sprinkle with flake sea salt.
5. Bake until center is set and a toothpick or cake tester comes out clean, about 35 to 40 minutes, rotating the pan halfway through baking. Do not overbake. Remove from oven and set on wire rack. Let cool completely in pan.
6. To serve, use the foil overhang to lift the bar out of baking pan and transfer to a cutting board. Remove foil and cut into 24 squares. Blondies will keep stored at room temperature in an airtight container for up to 5 days.

Nutritional information per blondie:

Calories 265 (14% from fat) • carb. 30g • pro. 5g • fat 14g • sat. fat 5g • chol. 33mg • sod. 113mg
calc. 91mg • fiber 2g

Plum Crumble Bars

A crumble topping that doubles as a crust is the way to go for a simple dessert. Delicious with any summer fruit, but we especially love plums for their vivid color and sweet-tart complexity.

Yield: 12 bars

INGREDIENTS

Nonstick cooking spray, for the pan		<u>Crust/Crumble:</u>	
<u>Filling:</u>		2	cups unbleached, all-purpose flour
1½	pounds black plums, halved and pitted	⅓	cup granulated sugar
⅔	cup granulated sugar	¼	cup packed light brown sugar
	Pinch kosher salt	1	teaspoon kosher salt
¼	teaspoon ground allspice	½	teaspoon grated lemon zest
¼	teaspoon ground cardamom	14	tablespoons (1¾ sticks) very cold unsalted butter, cut into pieces
¼	teaspoon ground cinnamon	⅓	cup rolled oats
¼	teaspoon ground ginger	1	large egg white whisked with 1 teaspoon water, to seal crust
4	teaspoons arrowroot		
1	teaspoon fresh lemon juice		

INSTRUCTIONS

1. Preheat oven to 375°F with the rack in the middle position. Lightly coat a 9 x 9-inch pan with nonstick cooking spray and line with parchment paper, leaving overhang on two sides.
2. Prepare the filling. Insert the slicing disc, set to 7mm, into the food processor. Slice the plums. In a medium bowl, whisk together sugar, salt, and spices. Add the plums and lemon juice, and gently toss with your hands until well mixed. Set aside to macerate. Clean out the work bowl.
3. Make the crumble. Insert the chopping blade into the work bowl. Add the flour, sugars, salt, and zest and process on Low for 10 seconds to sift. Add butter and pulse in 3-second long bursts until the mixture is very sandy and crumb-like, about 15 pulses. Transfer 1½ cups of the crumble into a small mixing bowl. Mix in ⅓ cup oats with your hands, pinching the mixture together until crumbs form. Cover with plastic wrap and refrigerate until ready to bake. Transfer the remaining crumble to the prepared pan and press into an even layer to form crust. Freeze until firm, about 15 to 20 minutes. Prick all over with the tines of a fork and bake until golden brown, about 18 to 20 minutes. Remove and set pan on wire rack. Lightly brush with egg wash and let cool completely to room temperature.
4. While the crust cools, drain the plums in a strainer set over a medium saucepan. Return the slices to the bowl. Bring the juice to a simmer over medium heat. Reduce heat and continue to cook, stirring frequently, until thickened, about 3 to 4 minutes. Remove from heat. Allow to cool, then whisk in arrowroot and lemon juice.
5. Bake the bars. Mix the cooled syrup into the sliced plums. Pour the filling over the cooled crust and spread in an even layer. Sprinkle the remaining crumble evenly over the top. Bake for 50 to 55 minutes, until filling bubbles at edges and the crumb topping is golden brown. Remove from oven and set on a wire rack. Let cool completely in pan.
6. To serve, use a sharp knife to release edges. Use parchment overhang to lift the bar from pan and transfer to a cutting board. Cut into 12 rectangles.

Nutritional information per bar:

Calories 310 (39% from fat) • carb. 45g • pro. 3g • fat 14g • sat. fat 8g • chol. 35mg • sod. 109mg
calc. 49mg • fiber 2g

Banana-Chip “Ice Cream” with Peanut Butter Swirl

You will be amazed how a handful of frozen bananas transform into a creamy ice cream-like texture in minutes.

Yield: about 2 cups

INGREDIENTS

4	very ripe bananas, cut into 1- to 2-inch pieces, frozen		Pinch fine sea salt
¼	teaspoon pure vanilla extract	¼	cup semi or bittersweet chocolate chips
2	tablespoons coconut milk	¼	cup peanut butter, unsweetened

INSTRUCTIONS

1. Insert the chopping blade into the work bowl of the food processor. Put the bananas, vanilla extract, coconut milk, and salt into the work bowl. Pulse 10 times, using long pulses. Scrape the work bowl and then process for about 2 to 3 minutes until smooth. Add the chips and pulse about 5 times to break up and incorporate. Add the peanut butter and process on Mix to create a swirl.
2. For best results, serve immediately or place in a container to be stored in the freezer. Cover ice cream with plastic wrap directly if freezing.

Nutritional information per serving (1/3 cup):

Calories 196 (41% from fat) • carb. 26g • pro. 4g • fat 9g • sat. fat 3g • chol. 0mg • sod. 27mg • calc. 4mg • fiber 3g

Banana-Chip “Ice Cream” Sandwiches

A combination that will be sure to please. Wrapping these sandwiches well and keeping in the freezer in a seal-tight bag will ensure that these treats will stay fresh for up to a couple of weeks.

Yield: 6 sandwiches

INGREDIENTS

1	dozen prepared Chocolate Chunk Cookies (page 45)	1	recipe Banana Chip “Ice Cream” with Peanut Butter Swirl (previous recipe)
---	--	---	---

INSTRUCTIONS

1. Scoop 1/3 cup of the Banana Chip “Ice Cream” on top of 6 of the cookies. Press another cookie on top of each scoop of “ice cream,” and twist and press to seal.
2. Wrap each sandwich very well and freeze for about 1 hour.
3. Serve well chilled. Wrapped sandwiches can be frozen for up to 1 month.

Nutritional information per sandwich:

Calories 460 (44% from fat) • carb. 59g • pro. 6g • fat 23g • sat. fat 12g • chol. 36mg • sod. 183mg
calc. 6mg • fiber 4g

Carrot Cake with Cream Cheese Frosting

The food processor makes this classic cake a breeze – it does all the work from shredding the carrots to making the frosting.

Yield: one 2-layer cake, about 16 servings

INGREDIENTS

	Nonstick cooking spray	1½	teaspoons pure vanilla extract
Cake:			Cream Cheese Frosting:
2	cups unbleached, all-purpose flour	Yield: about 3½ cups	
2	teaspoons ground cinnamon	8	ounces cream cheese (1 standard package), cut into 8 pieces, room temperature
1½	teaspoons baking powder	8	tablespoons (1 stick) unsalted butter, cut into 8 pieces, room temperature
½	teaspoon baking soda	2	ounces goat cheese, room temperature (sour cream or plain yogurt can be substituted)
1	teaspoon fine sea salt	2	cup confectioners' sugar
1	cup walnuts, toasted	¼	teaspoon fine sea salt
1	pound carrots (6 to 8 medium), peeled	¼	teaspoon pure vanilla extract
1	cup granulated sugar		
1	cup packed light or dark brown sugar		
1	cup vegetable oil		
4	large eggs		

INSTRUCTIONS

1. Preheat oven to 350°F with the rack in the middle position. Coat two 9-inch round baking pans with nonstick cooking spray and line the bottoms with parchment; set aside.
2. Insert the chopping blade into the work bowl of the food processor. Add the flour, cinnamon, baking powder, baking soda, and salt. Process on Low for 30 seconds to sift. Transfer to a large mixing bowl.
3. Put the walnuts into the work bowl and pulse 2 to 3 times to coarsely chop. Leaving the nuts in the bowl, remove the chopping blade and replace it with the medium shredding disc. Shred the carrots on High. Add the nuts and carrots to the bowl with the dry ingredients.
4. Remove the shredding disc and replace it with the chopping blade. Add the sugars to the work bowl. In a large measuring cup, combine the oil, eggs and vanilla extract. While the unit is running on Mix, gradually add the wet ingredients through the feed tube. Process until well mixed, about 30 to 45 seconds, stopping to scrape down the sides of the bowl as needed. Add the wet ingredients to the bowl of dry ingredients and stir until just combined.
5. Pour the batter into the prepared pans and bake for 35 minutes or until a cake tester inserted in the center comes out clean. Cool completely in the pans.
6. Prepare the frosting. Clean the chopping blade and insert into the cleaned work bowl. Add the cream cheese and butter and process on High until smooth, about 60 seconds, stopping to scrape down the sides of the bowl. Add the goat cheese; process another 10 to 15 seconds. Add the sugar, salt, and vanilla extract, and process until completely smooth, another 15 to 20 seconds.
7. Once the cakes have cooled, invert and peel off parchment. Transfer one layer to a cake stand or plate and spread evenly with frosting. Top with the second layer. Frost the top and sides of cake evenly using an offset spatula. Chill cake slightly before serving.

Nutritional information per serving:

Calories 428 (53% from fat) • carb. 46g • pro. 6g • fat 26g • sat. fat 5g • chol. 63mg • sod. 319mg calc. 229mg • fiber 2g

Strawberry-Rhubarb Pie

A classic pie made simple, thanks to the versatility of the food processor.

Yield: 12 servings

INGREDIENTS

1	recipe prepared Pâte Brisée (page 60), divided into two discs	¼	teaspoon fresh lemon juice
1	pound rhubarb, trimmed	1	pound strawberries, hulled
⅔	cup granulated sugar	4½	teaspoons tapioca starch
	Pinch fine sea salt		Egg wash (1 large egg whisked with 1 teaspoon water)
¼	teaspoon pure vanilla extract		Granulated sugar for sprinkling

INSTRUCTIONS

1. Roll one pastry disc to a 12-inch circle, about ⅛ inch thick, and fit into a 9-inch pie plate, with a bit of dough hanging over the sides. Cover and chill for a minimum of 30 minutes (you want the pastry to be firm. This can also be done in the freezer if time is short; cover and freeze for 15 minutes). Roll the other into a 10-inch circle, again about ⅛ inch thick. Cut out decorative pieces from the smaller circle (this can be done with a small cookie cutter or the end of a pastry tip. You can also freehand cut. It is best to do one cut in the center and then about 4 to 6 around that center cut). Cover and chill until firm, again no less than 30 minutes.
2. Insert the slicing disc, set to 6mm, into the work bowl of the food processor. Slice rhubarb and then transfer to a large, shallow mixing bowl. Add the sugar, salt, vanilla extract, and lemon juice. Stir so the rhubarb is fully coated. Slice the strawberries, again on 6mm, and then add to the rhubarb mixture with the tapioca starch. Let sit while preheating the oven.
3. Preheat oven to 400°F with the rack in the middle position (preferably with a baking stone or steel. If using either a baking stone or steel, be sure to preheat for an additional 30 minutes).
4. Remove the pie plate from the refrigerator or freezer and, using the tines of a fork, prick the bottom of the pie crust. Transfer the strawberry-rhubarb mixture into the crust and then fit the other pie dough disc on top. Fold over the dough and crimp as desired. Lightly brush the top of the crust with the egg wash and sprinkle with the sugar.
5. Transfer to the preheated oven and bake until the filling is bubbling and the crust is nicely browned, about 35 to 40 minutes.
6. Remove and transfer to a wire rack to cool completely. The pie needs to be room temperature, or cooler, to set the filling.

Nutritional information per serving:

Calories 216 (46% from fat) • carb. 28g • pro. 2g • fat 11g • sat. fat 8g • chol. 30mg • sod. 146mg
calc. 39mg • fiber 2g

Pistachio Olive Oil Cake with Cardamom Cream

The good fats in the pistachios and olive oil make this cake perfectly moist.

Yield: one 9-inch layer cake, 16 servings

INGREDIENTS

Cake:

1	cup shelled pistachios, plus 2 tablespoons, finely chopped, for serving
1	cup granulated sugar
1	cup unbleached, all-purpose flour
1	cup almond meal
1½	teaspoons baking powder
½	teaspoon fine sea salt
1	cup olive oil
4	large eggs
1	teaspoon pure almond extract

Cardamom Cream:

8	tablespoons (1 stick) unsalted butter, softened
4	ounces (½ standard package) cream cheese, room temperature
1½	cups powdered sugar, sifted
1	teaspoon pure vanilla extract
	Pinch fine sea salt
1 to 2	pinches ground cardamom
2	tablespoons plain yogurt

INSTRUCTIONS

1. Grease 9-inch round cake pan and line the bottom with parchment paper. Preheat oven to 350°F with the rack in the middle of the oven.
2. Insert the chopping blade into the work bowl of the food processor. Add the cup of pistachios, sugar, flour, almond meal, baking powder, and salt to the work bowl. Pulse a few times, then process on High for 1 minute to ensure the pistachios are finely chopped and the mixture is completely combined.
3. With the machine running on Mix, slowly add the oil, eggs, and almond extract through the feed tube.
4. Scrape down and then pulse a few more times if necessary. The batter will be very thick. Scrape it into the prepared cake pan and smooth over the top. Clean the work bowl and chopping blade.
5. Put the cake into the preheated oven and bake until the cake is just coming away from the sides of the pan, about 35 to 40 minutes. Cool on rack and then remove from pan to cool completely before topping.
6. When the cake is cool, prepare the filling and topping. Insert the chopping blade into the work bowl. Add all the ingredients, except for the yogurt, to the bowl and process on Low to combine, then stop to scrape down the sides. Continue to process until very light and fluffy. Add the yogurt and mix on Low until desired consistency is achieved.
7. Halve the cake to make two layers. Spread some of the cardamom cream in the center of the bottom layer, leaving a half-inch border. Top with the second cake layer and then put the remaining cardamom cream on the top. Spread evenly over the top and sides of the cake. Put in the refrigerator to chill for 30 minutes.
8. Once chilled, decorate with the finely chopped pistachios.

Nutritional information per serving:

Calories 403 (62% from fat) • carb. 33g • pro. 6g • fat 28g • sat. fat 7g • chol. 64mg • sod. 137mg calc. 101mg • fiber 2g

Almond Paste

Almond paste is a delicious addition to sweet rolls and bread, cookies and cakes. It lasts for quite some time in the refrigerator, about 3 weeks, and up to 3 months in the freezer.

Yield: 1½ cups, about 1 pound

INGREDIENTS

1½	cups blanched almonds*	2	tablespoons water
1½	cups confectioners' sugar, plus more for dusting	1	teaspoon pure almond extract
1	tablespoon honey	¼	teaspoon fine sea salt

INSTRUCTIONS

1. Insert the chopping blade into the work bowl of the food processor. Add the almonds and pulse about 4 times to break up, and then process on High until finely ground, about 30 seconds. Add the remaining ingredients and allow to process, on High, until very well mixed. The goal is to get the mixture as finely ground and dough-like as possible.
2. Lightly dust a clean work surface with confectioners' sugar. Knead the almond paste a few times into the sugar and then wrap well in plastic wrap. Store at room temperature for up to 1 week. If not using for some time, store in the refrigerator for up to 3 weeks or in the freezer for up to 3 months (bring to room temperature before using).

***Note:** You can purchase blanched almonds, but those can be pricey, and they are not readily available in all stores. You can easily blanch your own almonds at home by following these few simple steps: Put whole almonds (raw) into a heatproof mixing bowl. Bring about 3 to 4 cups of water to a boil and then pour the boiling water over the almonds. Allow to sit for exactly 1 minute – no more than that or the almonds will be too soft. Immediately drain into a colander or strainer and then rinse and cool with cold water. Return the almonds to the empty mixing bowl. The skins of the almonds should be shriveled. Using your fingers, rub the almonds; and the skins should easily come off. Discard the skins.

Nutritional information per serving (2 tablespoons):

Calories 173 (47% from fat) • carb. 20g • pro. 4g • fat 10g • sat. fat 1g • chol. 0mg • sod. 51mg • calc. 43mg • Fiber 9g

Sour Cream Cheesecake

The Cuisinart food processor processes this classic cake in moments.

Yield: one 9-inch cheesecake, 12 servings

INGREDIENTS

Graham Cracker Crust:

- 6 tablespoons unsalted butter, melted and cooled slightly
- 9 graham crackers sheets, broken up
- 2 tablespoons granulated sugar
- ½ teaspoon ground cinnamon

Cheesecake Filling:

- 3 (8 ounces each) packages cream cheese, room temperature, each cut into 6 pieces
 - 1½ cups granulated sugar
 - 5 large eggs, room temperature
 - 1 teaspoon pure vanilla extract
 - 3 cups sour cream, room temperature
 - Fresh berries, for serving
-

INSTRUCTIONS

1. Preheat oven to 350°F. Butter a 9-inch spring form pan.
2. Prepare the crust. Insert chopping blade into the work bowl of the food processor. Add all the crust ingredients and process on Low until fully combined. Transfer crumbs to the 9-inch springform pan. Press crumbs evenly and firmly to coat the bottom of the pan and up the sides. Use the bottom of a glass or measuring cup to aid in the process. Bake for 10 minutes in a 350°F oven to set. Remove and reserve. Reduce temperature to 325°F. Have a roasting pan at the ready.
3. Wipe the work bowl and chopping blade clean and then return the chopping blade to the work bowl. Add the cream cheese and process on High until creamy. Scrape the bowl. While mixing on Low, add the granulated sugar through the feed tube. Scrape the bowl and then mix on Low again, this time adding the eggs, one at a time, and vanilla extract through the feed tube.
4. Scrape the sides of the bowl and add the sour cream. Process on Mix until just incorporated.
5. Pour filling into prepared pan. Wrap the pan well with foil and then place in the roasting pan. Fill the roasting pan with hot water until it reaches halfway up the sides of the springform pan.
6. Bake the cheesecake until the outer edges are just set, but the center is still jiggly, about 1 hour. Turn oven off and leave cheesecake to rest in oven for an additional hour. Remove and cool completely.
7. Once completely cool, wrap well with plastic wrap and refrigerate for at least 6 hours before serving.
8. Serve with fresh berries.

Nutritional information per serving (based on 12 servings):

Calories 550 (64% from fat) • carb. 39g • pro. 9g • fat 39g • sat. fat 23g • chol. 193mg • sod. 280mg
calc. 55mg • fiber 0g

Oatmeal Bread

A light, but hearty bread, perfect for sandwiches.

Yield: 1 loaf (1½ pounds)

INGREDIENTS

1¼	cups warm water (105°F to 110°F)	¼	cup dried milk powder
1	tablespoon maple syrup	1½	teaspoons fine sea salt
2¼	teaspoons (1 packet) active dry yeast	3	tablespoons unsalted butter, room temperature, cut into 1-inch pieces
3	cups bread or unbleached, all-purpose flour	¾	cup old-fashioned rolled oats

INSTRUCTIONS

1. In a 2-cup liquid measuring cup, dissolve yeast in the warm water with the maple syrup. Let stand until foamy, about 5 minutes.
2. Insert the chopping blade into the work bowl of the food processor. Add the flour, dried milk powder, salt, and butter to the work bowl and process on Low to combine, about 10 to 15 seconds.
3. Add the oats, and then, with the food processor running on Low, add the yeasted water mixture through the small feed tube, only as fast as flour absorbs it. Once dough cleans the sides of the work bowl and forms a ball, continue processing, kneading for 45 seconds.
4. Transfer dough to a large bowl lightly dusted with flour. Cover with plastic wrap and allow to rise in a warm place until doubled, about 1 to 1½ hours.
5. After the dough has doubled in size, lightly coat a 9-inch loaf pan with nonstick cooking spray. Reserve. Punch down dough, and form into a loaf and transfer to the prepared loaf pan. Cover with plastic wrap. Allow to rise until dough is just above the top of the pan, about 45 minutes to 1 hour.
6. Preheat oven to 400°F. Bake until the top is browned and loaf sounds hollow when tapped, about 30 to 35 minutes. Remove from pan and cool on wire rack. Cool completely before slicing.

Nutritional information per serving (based on 16 servings):

Calories 123 (21% from fat) • carb. 21g • pro. 3g • fat 3g • sat. fat 2g • chol. 8mg • sod. 230mg • calc. 20mg • fiber 1g

Popovers

Light and airy, these are best served hot out of the oven.

Yield: 6 popovers

INGREDIENTS

	Softened butter for greasing the pan	3	large eggs, room temperature
3	tablespoons unsalted butter	1	cup unbleached, all-purpose flour, sifted
1	cup whole milk	½	teaspoon kosher salt

INSTRUCTIONS

1. Put the 3 tablespoons of butter and milk in a small saucepan set over medium-low heat. Warm until butter has melted; remove and cool to room temperature.
2. Insert the chopping blade into the work bowl of the food processor. Add the eggs, flour, cooled milk/butter mixture, and salt and process on High until completely smooth, about 20 to 30 seconds. Transfer to a large measuring cup and allow to rest at room temperature for about 30 to 45 minutes.

3. Preheat oven to 425°F (use convection bake, if available). Heavily butter or coat with nonstick cooking spray two 6-cup popover pans or twelve, 5-ounce ramekins or muffin cups and place on two baking sheets. Fill each cup/ramekin with about ⅓ cup of batter. Place in oven and bake for 30 minutes, or until nicely and evenly browned. Remove from oven and carefully remove popovers from cups/ramekins. Serve immediately.

Note: Popovers are easily adaptable. You can make them cheesy (stir ¼ cup finely shredded cheese into the batter), herby (1½ teaspoons of herbes de Provence or 2 tablespoons of fresh chives), or sweet (once out of oven, brush with melted butter and sprinkle with cinnamon sugar).

Nutritional information per popover:

Calories 183 (46% from fat) • carb. 17g • pro. 7g • fat 9g • sat. fat 5g • chol. 128mg • sod. 146mg
calc. 60mg • fiber 1g

Whole-Wheat Sandwich Bread

The addition of pepitas (hulled pumpkin seeds) adds a nice crunch to this healthy loaf.

Yield: 1 loaf (about 1¾ pounds)

INGREDIENTS

1¼	cups water (105°F to 110°F)	¼	cup dried milk powder
2	tablespoons molasses	2	tablespoons cocoa powder
2¼	teaspoons active dry yeast	1½	teaspoons fine sea salt
1½	cups unbleached, all-purpose flour	3	tablespoons unsalted butter
1½	cups whole-wheat flour	⅓	cup hulled pumpkin seeds (pepitas)

INSTRUCTIONS

1. In a 2-cup liquid measuring cup, dissolve yeast in the warm water with the molasses. Let stand until foamy, about 5 minutes.
2. Insert the chopping blade into the work bowl of the food processor. Add the flours, dried milk powder, cocoa powder, salt, and butter to the work bowl and process on Low to combine, about 10 to 15 seconds.
3. With the food processor running on Low, add the yeasted water mixture through the small feed tube, only as fast as flour absorbs it. Once dough cleans the sides of the work bowl and forms a ball, continue processing for 45 seconds to knead.
4. Knead in the pumpkin seeds by hand, and then knead for an additional minute or two, until the dough is very smooth. Shape into a smooth ball and transfer to a large bowl. Cover with plastic wrap and allow to rise in a warm place until doubled, about 1 to 1½ hours.
5. After the dough has doubled in size, lightly coat a 9-inch loaf pan with nonstick cooking spray. Reserve. Punch down dough and form into a loaf and transfer to the prepared loaf pan. Cover with plastic wrap. Allow to rise until dough is just above the top of the pan, about 45 minutes to 1 hour.
6. Preheat oven to 400°F. Bake until the top is browned and loaf sounds hollow when tapped, about 30 to 35 minutes. Remove from pan and cool on wire rack. Cool completely before slicing.

Nutritional information per serving (based on 16 servings):

Calories 142 (27% from fat) • carb. 22g • pro. 5g • fat 4g s • sat. fat 2g • chol. 8mg • sod. 231mg • calc. 33mg • fiber 2g

Pita Bread

The key to achieving the signature pocket in a pita bread is a smooth dough and a very hot oven and baking pan.

Yield: six 8-inch pitas

INGREDIENTS

1¾	teaspoons active dry yeast	1	cup whole-wheat flour
	Pinch granulated sugar	1½	teaspoons kosher salt
1	cup warm water (105°F to 110°F)	1	tablespoon olive oil
2	cups unbleached, all-purpose flour		

INSTRUCTIONS

1. Put the yeast, sugar, and water into a liquid measuring cup. Let stand for 5 to 10 minutes until foamy.
2. Insert the chopping blade into the work bowl of the food processor. Add the flours and the salt and process on Low to sift. When the yeast is proofed, run the food processor on Low and slowly add the yeast mixture through the feed tube, following with the olive oil. Continue to process for 40 seconds to knead. The dough should be soft, smooth, and slightly tacky.
3. Turn the dough out onto a clean work surface and knead for another minute or two by hand to soften some more. Add additional flour if the dough seems too sticky, or a little water if it seems too dry.
4. Transfer the dough to a clean bowl and cover with a damp towel or plastic wrap. Let the dough sit at room temperature for about 1 hour, or until it has doubled in size.
5. Divide the dough into 6 pieces. Lightly flour a clean work surface with flour and shape each into a ball. Cover the balls with a damp towel or plastic wrap and allow to rise for another 30 minutes.
6. Put a baking sheet in the middle of an oven and preheat to 500°F.
7. While the oven is preheating, roll each round into an 8-inch circle. Starting with 2 or 3 at a time, transfer the dough circles to the hot pan and bake until lightly golden and puffed, about 4 to 5 minutes. Transfer to a serving plate and loosely cover to keep warm. Repeat with remaining dough circles.
8. Serve warm, stuffed with your favorite fillings.

Nutritional information per pita:

Calories 199 (25% from fat) • carb. 33g • pro. 5g • fat 6g • sat. fat 1g • chol. 0mg • sod. 429mg • calc. 6mg • fiber 2g

Sour Cream & Onion Potato Pull-Apart Rolls

Don't be surprised how quickly these rolls will disappear – that's just their cloud-like nature.

Yield: 18 rolls

INGREDIENTS

1	medium (7 ounces) Yukon gold potato	½	teaspoon freshly ground black pepper
½	cup reserved potato cooking liquid	¾	cup sour cream
2	teaspoons active dry yeast	1	large egg
1	bunch (about 6) scallions (2¾ ounces), cut into 1-inch pieces	1	large egg yolk
4¼	cups bread flour, plus more for dusting	8	tablespoons (1 stick) unsalted butter, cut into pieces, room temperature, divided
2	tablespoons, plus 2 teaspoons granulated sugar		Flake sea salt, for sprinkling
2¾	teaspoons kosher salt		

INSTRUCTIONS

1. Place potato in a medium saucepan and add enough cold water to cover. Bring to a boil over medium-high heat, reduce to a simmer, and cook until tender, 35 to 40 minutes. Transfer potato to plate and let cool slightly. Reserve ½ cup of the cooking liquid on a liquid measuring cup; let stand until temperature is 105°F to 110°F. When liquid is cool enough, add the yeast and let stand until foamy, about 5 to 10 minutes.
2. Meanwhile, insert the medium shredding disc into the food processor. Peel the potato and shred. Transfer to plate and reserve.
3. Replace the shredding disc with the chopping blade. Add the scallions and pulse to finely chop. Add the flour, the 2 tablespoons of sugar, salt and pepper, and pulse to blend. Add the reserved potato, sour cream, egg, egg yolk, and 4 tablespoons butter to the work bowl. With the machine running on Low, slowly add the yeast mixture through the feed tube. Continue to process for 40 seconds to knead. The dough should be soft and slightly sticky.
4. Scrape the dough out onto a lightly floured surface and knead for 1 to 2 minutes, until smooth. Refrain from adding flour. Use a bench scraper to unstick dough from surface. Shape into a ball and place in a greased bowl. Cover the bowl with plastic wrap and let rise in a warm place until 1½ times its original size, about 45 to 60 minutes.
5. Grease the bottom and sides of a 13 x 9-inch pan with 1 tablespoon butter. Divide the dough into 18 equal pieces (about 2 ounces each). Shape rolls, gently cupping your hand around the dough and using the work surface to roll it in a circular motion to form a tight ball. Arrange rolls in the prepared pan, spacing to make a 6 x 3 grid. Cover with plastic wrap and let rise in a warm place until nearly doubled in size, about 45 to 60 minutes.
6. Preheat the oven to 375°F. Melt 2 tablespoons of butter in a small saucepan. Evenly brush the tops of the rolls with butter and sprinkle with flake sea salt. Bake rolls until golden brown, about 18 to 22 minutes.
7. Meanwhile, melt remaining tablespoon butter. Remove pan from oven and immediately brush rolls with melted butter. Let cool in pan for 5 minutes, then carefully lift out and transfer to wire cooling rack.
8. Serve warm or let cool. Rolls can be baked 2 days ahead. Let cool completely and store airtight for up to 5 days at room temperature.

Nutritional information per serving:

Calories 195 (34% from fat) • carb. 27g • pro. 5g • fat 7g • sat. fat 5g • chol. 34mg • sod. 349mg • calc. 12mg • fiber 0g

Yeasted Sweet Dough

This is a versatile sweet bread dough that can be used for a sweet loaf bread, like a cinnamon-swirl style, or individual buns, such as our Sweet Almond Chocolate Rolls on page 21.

Yield: 1½ pounds dough (enough for 1 large loaf of bread or 8 to 12 individual rolls/buns)

INGREDIENTS

⅓	cup warm water (105°F to 110°F)	3	cups bread flour or unbleached, all-purpose flour
2¼	teaspoons active dry yeast		
5	tablespoons granulated sugar, divided	½	teaspoon fine sea salt
2	large eggs, room temperature	4	tablespoons (½ stick) unsalted butter, room temperature, and cubed
¼	cup sour cream, room temperature		

INSTRUCTIONS

1. In a liquid measuring cup, dissolve the yeast and 2 tablespoons of the sugar in the warm water. Let stand until foamy, about 5 minutes.
2. Once foamy, add the eggs and sour cream and whisk together well.
3. Insert the chopping blade into the work bowl of the food processor. Add the flour, salt, and remaining sugar to the work bowl.
4. Process on Low to combine, and while still on Low, slowly pour the yeast mixture through the feed tube until all ingredients are combined. If it does not form a dough ball, add additional water, 1 tablespoon at a time.
5. With machine running again on Low, add cubed butter, a little at a time so that each piece is incorporated before adding the next. Continue to process until dough is smooth, about 2 to 3 minutes.
6. Dough will be sticky, but should not be greasy. If greasy, process for an additional minute.
7. Transfer dough to a clean surface and knead by hand for a few minutes. Put into a bowl and cover with a damp towel or plastic wrap. Allow to rise until doubled, about 1½ hours. Use dough as desired.

Nutritional information per serving (based on 12 servings):

Calories 178 (27% from fat) • carb. 28g • pro. 5g • fat 5g • sat. fat 4g • chol. 44mg • sod. 103mg • calc. 8mg • fiber 1g

Pizza Dough

Homemade pizza dough is the perfect start to family pizza night.

Yield: about 1 pound of dough (one 14-inch pizza or two 8-inch pizzas)

INGREDIENTS

1½	teaspoons active dry yeast	1¾	cups bread flour or unbleached, all-purpose flour
1	teaspoon granulated sugar		
⅔	cup warm water (105°F–110°F)	¾	teaspoon kosher salt
		2	teaspoons olive oil

INSTRUCTIONS

1. In a liquid measuring cup, dissolve the yeast and sugar in warm water. Let stand until foamy, about 5 minutes. (**Note:** If the yeast does not get foamy within 10 minutes, that means that it is not active and you should toss it and start again with new yeast.)

2. Insert the chopping blade into the work bowl of the food processor. Add the flour, salt, and olive oil to the bowl, and pulse a few times to combine. With the machine running on Low, pour the liquid mixture through the feed tube as fast as the flour absorbs it. Process until the dough cleans the sides of the work bowl and forms a ball. Continue to process for 30 seconds to knead the dough. Dough should be slightly sticky.
3. Transfer the dough to a clean surface and knead by hand for an additional minute. Put the dough into a clean bowl and cover with a damp towel or plastic wrap. Let it rise in a warm, draft-free place for about 1 hour; dough should double in size.
4. Place dough on a lightly floured surface and gently fold over to “punch” down. Form into desired crust size(s) as directed by recipe.

Nutritional information per serving (based on 8 servings):

Calories 92 (6% from fat) • carb. 19g • pro. 3g • fat 1g • sat. fat 0g • chol. 0mg • sod. 214mg • calc. 1mg • fiber 0g

Pretzels with Rosemary and Flake Sea Salt

Soft pretzels made at home will be the new way to wow your house guests. The rosemary and flake sea salt elevate these chewy soft pretzels, but the traditional coarse salt can be used.

Yield: 8 soft pretzels

INGREDIENTS

1	cup warm water (105°F to 110°F)	Baking soda wash (½ cup warm water and 1 teaspoon baking soda whisked together to dissolve baking soda)
1	tablespoon packed light brown sugar	Egg wash (1 large egg plus 1 teaspoon water, whisked well)
2¼	teaspoons active dry yeast	Flake sea salt, for sprinkling
2½	cups bread flour or unbleached, all-purpose flour	Chopped fresh rosemary, for sprinkling
1½	teaspoons kosher salt	

INSTRUCTIONS

1. Put the water, sugar, and yeast in a liquid measuring cup; stir to dissolve. Let stand 5 to 10 minutes, or until mixture is foamy.
2. While the yeast is proofing, put the flour and salt into the work bowl fitted with the chopping blade. Process on Low to sift. With the machine running on Low, pour the liquid mixture through the feed tube as fast as the flour absorbs it. Process until the dough cleans the sides of the work bowl and forms a ball. Continue to process for 30 seconds to knead the dough. Dough should be slightly sticky.
3. Transfer the dough to a clean surface and knead by hand for an additional minute. Put the dough into a clean bowl and cover with a damp towel or plastic wrap. Let it rise in a warm, draft-free place for about 1 hour; dough should double in size.
4. Gently punch dough down and then roll into a 12-inch rope. Divide dough into 8 equal pieces. Roll each piece into a thin rope. Twist dough into a pretzel shape by taking the two ends and crossing them over one another, making sure that the ends hang over the bottom; press firmly to seal. Place on a baking sheet lined with parchment paper. Repeat with remaining pieces of dough, being sure to keep all shaped pretzels under plastic wrap or a damp towel.
5. Allow pretzels to rest for about 20 to 30 minutes. While they are resting, stir together the 2 cups of water and baking soda together in a small bowl.
6. Place a 6-quart saucepan filled with water over high heat and bring to a boil. Preheat oven to 425°F.
7. Once pretzels have rested and water comes to a boil, carefully slide one pretzel into the boiling

water at a time, flipping each after 1½ minutes. Boil for 3 minutes total. Allow pretzels to drain on a wire cooling rack. Dip each pretzel into the stirred baking soda solution and place on prepared baking sheet. Lightly brush the pretzels with the egg wash and sprinkle generously with the salt and rosemary. Bake in the oven until dark and golden, approximately 10 to 12 minutes.

8. When pretzels are finished baking, transfer to a wire cooling rack.

Nutritional information per pretzel:

Calories 118 (0% from fat) • carb. 25g • pro. 4g • fat 0g • sat. fat 0g • chol. 0mg • sod. 261mg • calc. 1mg • fiber 1g

Pâte Brisée

This flaky pastry is a classic, all-butter dough that is very versatile. It can be used for sweet or savory pies and tarts.

Yield: 2 crusts (2 single pies/tarts or 1 double-crust pie)

INGREDIENTS

2	cups unbleached, all-purpose flour	16	tablespoons (2 sticks) unsalted butter, cold, and cut into ½-inch cubes
1	teaspoon fine sea salt	¼	cup ice water

INSTRUCTIONS

1. Insert the chopping blade into the work bowl of the food processor. Add the flour and salt to the work bowl and process on Low to sift.
2. Add the cubed butter over the top of the flour mixture. Pulse until the mixture resembles coarse crumbs, about 8 to 10 pulses. Add the ice water, 1 tablespoon at a time. Pulse until mixture just forms dough (you may not need all the water). Dough is ready when it holds when pinched together.
3. Divide the dough equally into 2 pieces and form each into a flat disc. Wrap each disc in plastic wrap and refrigerate for at least 30 minutes before using.
4. Dough keeps for up to a week in the refrigerator or in the freezer for up to 3 months.

Note: For a sweet pastry dough, add 1½ tablespoons granulated sugar in with the dry ingredients.

Nutritional information per serving:

Calories 100 (66% from fat) • carb. 7g • pro. 1g • fat 7g • sat. fat 5g • chol. 20mg • sod. 98mg • calc. 0mg • fiber 0g

©2021 Cuisinart
Glendale, AZ 85307
Printed in China

21CE078007

IB-17224-ESP