

Curtis 1206MX

This sheet is provided to aid in the installation of your remanufactured CURTIS controller. Upon installation, you may encounter problems that may, or may not, be due to a faulty controller. The following steps must be taken to help diagnose a possible cart fault or faulty controller. An analog or digital volt ohm meter (VOM) will be needed to perform these checks.



WARRANTY WILL BE VOID **If These Steps are Not Performed Before Installing The Control**

➔ STEPS TO PERFORM **BEFORE** CONTROL INSTALLATION ➔

CHECK MOTOR WINDINGS:

- Set your VOM to RESISTANCE (Ω).
- With your motor disconnected, measure A1 to A2. This must measure BETWEEN $.3\Omega$ and 1Ω .
- With your motor disconnected, measure F1 to F2. This must measure BETWEEN 1Ω and 2Ω .
- With your motor disconnected, measure A1 to F1. This must measure OPEN.
- With your motor disconnected, measure F1 to motor case. This must measure greater than $5M\Omega$.

CHECK MAIN SOLENOID:

- Disconnect all wires from the main solenoid.
- Set your VOM to RESISTANCE (Ω).
- Measure the solenoid coil. This must measure NO LESS than 100Ω .
- Connect VOM leads to the main solenoid lugs.
- Attach jumpers from the main battery positive and negative to the coil (small terminals).
- Meter must jump from infinity to LESS THAN $.3\Omega$.
- Remove jumpers and reconnect solenoid wiring from the harness. (If suppression diode is present, The non-banded side must go the blue wire – pin J1-6 from the controller.)

CHECK COTHERM:

- Inspect the cotherm (insulating material) mounted to the heat sink for holes, debris, and tears.
- Repair or replace, if necessary.

CHECK THE CART WIRE HARNESS:

- Check the connectors on the wire harness for corrosion, loose, broken, burnt or missing pins.
- Repair or replace pins as necessary.

**IF ANY OF THE ABOVE ITEMS ARE NOT WITHIN THE SPECIFIED RANGES THE CONTROLLER WILL FAIL.
THESE ITEMS MUST BE CORRECTED BEFORE THE CONTROLLER IS INSTALLED OR WARRANTY WILL BE VOID.**

It is recommended to replace your solenoid at the time of controller replacement. FSIP now stocks popular replacement White Rodgers solenoids for your convenience.

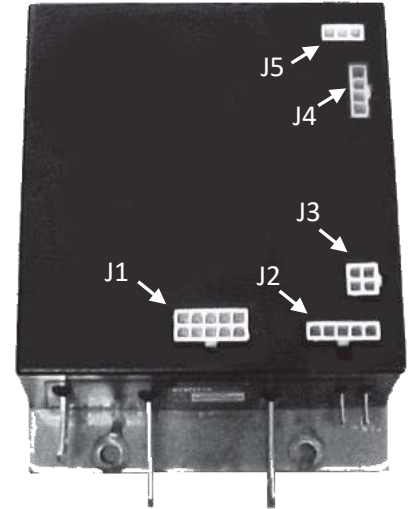
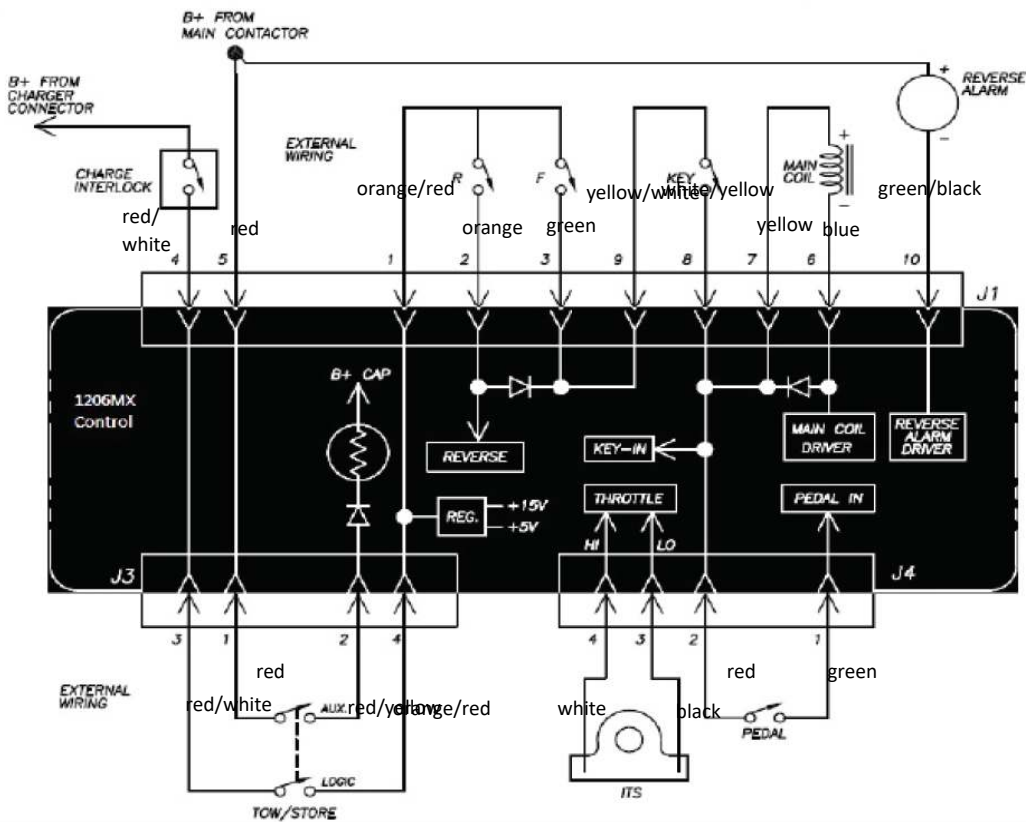

E-Z-GO PDS Troubleshooting Sequence

FOR SAFETY, ALWAYS LIFT THE DRIVE WHEELS OFF THE GROUND WHEN TROUBLESHOOTING!

ALL TESTS ARE CONDUCTED WITH RUN-TOW/MAINTENANCE SWITCH IN THE RUN POSITION AND WITH A GOOD BATTERY PACK VOLTAGE MEASUREMENT. ALSO, THE CONNECTOR MUST BE ATTACHED TO THE CONTROLLER WHEN MAKING THESE CHECKS. YOU WILL NEED TO 'BACK PROBE' THE PINS FROM THE WIRE SIDE OF THE CONNECTOR. USE A PAPERCLIP IF NECESSARY.

Attach voltmeter negative (-) lead to main battery – for the following tests

Use the following sequence when checking individual pins (don't skip steps). **If you find a fault, do not move on to the next step until the fault is corrected:**

- Measure the voltage at the main battery positive post (let's call it Pack Voltage)
- J1 Pin 5** Must be within 4 volts of Pack Voltage
 - If not, verify the Precharge Resistor is present and has good resistance
- J3 Pin 2** Must be same voltage as J1 Pin 5
 - If not, Run-Tow/Maintenance Switch or wiring is defective
- J1 Pin 4** **With charger disconnected**, must be at Pack Voltage
 - If not, the Reed Switch in the charger receptacle may be damaged (common failure)
- J3 Pin 4** Must be equal to Pack Voltage
 - If not, Run-Tow/Maintenance Switch or wiring is defective
- J1 Pin 1** Must be equal to Pack Voltage

Continued on next page ...

- J1 Pin 2** **With F/R Switch to Neutral**, must be approximately 0 volts
 - If not, check wiring, F/R switch for shorted condition
- J1 Pin 2** **With F/R Switch to Reverse**, must be equal to Pack Voltage
 - If not, check wiring, F/R switch for open condition
- J1 Pin 3** **With F/R Switch to Neutral**, must be approximately 0 volts
 - If not, check wiring, F/R switch for shorted condition
- J1 Pin 3** **With F/R Switch to Forward**, must be equal to Pack Voltage
 - If not, check wiring, F/R switch for open condition
- J1 Pin 9** **With F/R Switch to Forward or reverse**, must be equal to Pack Voltage
 - If not, check wiring or connector for contamination
- J1 Pin 8** **With Key Off**, must be equal to approximately 0 volts
 - If not, check Key Switch for shorted condition
- J1 Pin 8** **With Key On**, must be equal to approximately Pack Voltage
 - If not, check Key Switch for open condition
- J1 Pin 7** Must be equal to approximately Pack Voltage
 - If not, check wiring or connector for contamination
- J1 Pin 6** Must be equal to Pack Voltage
 - If not, check wiring, and solenoid for open condition
- J1 Pin 10** **With F/R Switch to Neutral**, must be Pack Voltage
 - If not, check wiring or backup beeper for an open or missing condition
- J1 Pin 10** **With F/R Switch to Reverse**, must pulse to approximately 0 volts (should hear beeper)
 - If not, check wiring or backup beeper for open condition
- J4 Pin 2** Must be equal to Pack Voltage
 - If not, check wiring or connector for contamination
- J4 Pin 1** **With Pedal not depressed**, must be equal to approximately 0 volts
 - If not, check wiring and Pedal Switch for shorted condition
- J4 Pin 1** **With Pedal fully depressed**, must be equal to Pack Voltage
 - If not, check wiring and Pedal Switch for open condition
- J4 Pin 4** Must be between 13 and 16 volts
 - If not, remove ITS Sensor and measure again. If voltage increases to 13 to 16 volts with sensor removed, replace ITS Sensor
- J4 Pin 3** **With Pedal not depressed**, must be approximately .5 to .9 volts
 - If not, check wiring. If wiring is good, issue may be with ITS Sensor
- J4 Pin 3** **With Pedal fully depressed**, must be approximately 2.5 to 3.3 volts
 - Voltages significantly outside of the .9 to 3.3 volt range may indicate an issue with the ITS Sensor. Replace as necessary.
- J5 Pin 3** Must be between 12 and 15 volts
 - If not, remove Speed Sensor and measure again. If voltage increases to 12 to 15 volts with sensor removed, replace Speed Sensor
- J5 Pin 2** **With drive wheels off the ground, s-l-o-w-l-y turn the drive wheel by hand.** Your meter should toggle between approximately 0 and 5 volts
 - If not toggling, check the motor magnet. If the magnet is cracked/damaged, replace magnet and recheck. If magnet is good, Speed Sensor or wiring is at fault.

Continued on next page ...

Helpful Hints

DO NOT UNDER ESTIMATE THE IMPORTANCE OF MOTOR RESISTANCE CHECKS AND MAIN SOLENOID CHECKS. MANY CART ISSUES ARE CAUSED BY BURNT/DAMAGED BRUSHES THAT WILL BE FOUND AS PART OF THE ARMATURE RESISTANCE CHECK. ALSO A SHORTED ARMATURE AND FIELD WITHIN THE MOTOR WILL DAMAGE THIS CONTROLLER.

This cart is capable of diagnostics! Placing the cart in the diagnostics mode will allow the controller to use the back-up alarm to beep out codes. **Do not under estimate the usefulness of this tool.** There is an orange and white sticker on the environmental cover that explains how to enter the diagnostic mode. For example, if your cart is traveling slow, and you enter diagnostics mode and it beeps the following sequence ...

<beep> <short pause> <beep> <beep> <beep> <long pause> <repeat>

That would represent a 1,3 code or Speed Sensor fault.

WARNING

TOWING
Always select 'TOW/MAINTENANCE' position before towing

- ⚠ Tampering with or unauthorized modification of this unit by non E-Z-GO personnel could result in serious personal injury, will void the warranty and result in permanent damage to the vehicle
- ⚠ Possibility of electrical arc or battery explosion. Before removing/connecting batteries or electrical components, turn switch to 'TOW MAINTENANCE' position

- To disable electrical system, place switch in 'TOW/ MAINTENANCE' position and remove battery wire
- After reconnecting batteries, allow a minimum of 30 seconds before selecting 'RUN' position

THE FOLLOWING CODES REQUIRE THAT THE REAR WHEELS BE RAISED BEFORE PERFORMING TESTS

Beep	Fault	Symptoms	Correction Required
1-1	Controller Failure	Vehicle will not run	Check motor wiring & motor Ω. Replace controller
1-2	Throttle fault	Solenoid clicks, will not run	Replace/adjust pedal box, harness
1-4	High pedal disabte	Vehicle will not run	Release pedal/check pedal box, linkage & switch
2-4	Solenoid coil failure or disconnected	Vehicle will not run	Check coil connections/wiring, replace solenoid if required
3-1	Solenoid driver fail	Vehicle will not run	Check coil wiring for shorts, replace controller
3-3	Solenoid did not close	Vehicle will not run	Check all solenoid wiring, replace solenoid if required
3-4	Field winding open	Solenoid clicks, will not run	Check motor & controller field connections, replace power harness or motor if required
4-1	Armature open	Solenoid clicks, will not run	Check motor & controller armature connections, replace power harness or motor if required
4-3	Solenoid drop out	Vehicle stops	Check solenoid/wiring, replace if required

THE FOLLOWING CODES REQUIRE THAT THE VEHICLE BE OPERATED UNDER LOAD WHILE PERFORMING TESTS

Beep	Fault	Symptoms	Correction Required
1-3	Speed sensor fault	Vehicle runs slowly	Check speed sensor connections & magnet/torque, replace speed sensor if required
2-1	Low battery voltage	Vehicle performance reduced	Charge batteries/replace bad batteries
2-2	High battery voltage	Regeon performance reduced	Check that battery voltage is less than 48 VDC
2-3	Thermal cutback	Vehicle performance reduced	Allow controller to cool, check heat sink bolt torque
3-2	Solenoid welded	Vehicle runs slowly	Check auxiliary power, Replace solenoid
4-2	Motor stalled	Vehicle stopped	Remove mechanical blockage

To enter diagnostic mode • Turn key switch to 'OFF' • Move 'RUN/TOW MAINTENANCE' switch to 'RUN'. • Move direction selector switch from neutral position to 'REV' position five (5) times • After a confirming beep(s) sounds, the diagnostic fault code will sound when a fault is detected. To exit diagnostic mode: Select 'TOW MAINTENANCE' position.

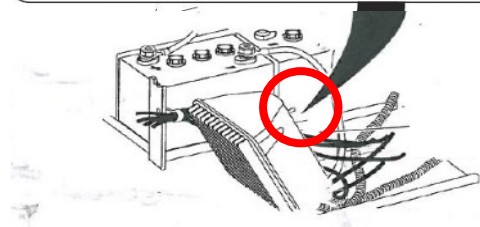

Flight Systems Industrial Products also offers the following Technical Support options ...



Troubleshooting Manuals / Codes
www.fsip.biz/TroubleshootingManuals.html



Technical Support Forum
fsip.websitetoolbox.com



Frequently Asked Questions
www.fsip.biz/FAQ.html

Phone Support
 1-800-333-1194

PRE-INSTALLATION
 INSTRUCTIONS MUST BE
 FOLLOWED OR WARRANTY
 WILL BE VOID

IMPORTANT! E-Z-GO PDS
 TROUBLESHOOTING INFORMATION
 INCLUDED IN THIS PACKET