



DAKE SINGLE PHASE DURA-PRESS

Force 10DA

INSTRUCTIONAL MANUAL



WARNING!

Read and understand all instructions and responsibilities before operating. Failure to follow safety instructions and labels could result in serious injury.

TABLE OF CONTENTS

DAKE STANDARD LIMITED WARRANTY	2
RETURN & REFUND POLICY	4
SAFEGUARDING THE POINT OF OPERATION.....	5
SPECIFICATIONS.....	6
SAFETY.....	7
SET UP.....	8
PRESS PLACEMENT	8
FILLING THE PRESS WILL OIL	8
WIRING INSTRUCTIONS	9
OPERATION	9
BEFORE FIRST TIME OPERATION.....	9
MAINTENANCE	10
LUBRICATION	10
HYDRAULIC LINES AND FITTINGS	10
TROUBLESHOOTING	11
EXPLODED VIEW & PARTS LIST.....	12
10 DA WORKHEAD DIAGRAM.....	14
ORDERING INFORMATION	14



DAKE STANDARD LIMITED WARRANTY

Finished Machines

Dake warrants to the original purchaser the finished machine manufactured or distributed by it to be free from defects in material and workmanship under normal use and service within 1 year (12 months) from the delivery date to the end user.

Parts

Dake warrants to the original purchaser the component part manufactured or distributed by it to be free from defects in material and workmanship under normal use and service within 30 days from the delivery date to the end user.

The standard limited warranty includes the replacement of the defective component part at no cost to the end user.

Sale of Service (Repairs)

Dake warrants to the original purchaser the component part repaired by Dake Corporation at the manufacturing facility to be free from defects in material and workmanship under normal use and service within 90 days from the return date to the end user, as it pertains to the repair work completed. The standard limited warranty includes repair of the defective component part, at no cost to the end user.

Warranty Process

Subject to the conditions hereinafter set forth, the manufacturer will repair or replace any portion of the product that proves defective in materials or workmanship. The manufacturer retains the sole right and option, after inspection, to determine whether to repair or replace defective equipment, parts or components. The manufacturer will assume ownership of any defective parts replaced under this warranty.

All requested warranty claims must be communicated to the distributor or representative responsible for the sale. Once communication has been initiated, Dake Customer Service must be contacted for approval:

Phone: (800) 937-3253

Email: customerservice@dakecorp.com

When contacting Dake, please have the following information readily available:

- Model #
- Serial #
- Sales Order #

Purchasers who notify Dake within the warranty period will be issued a Case number and/or a Return Material Authorization (RMA) number. If the item is to be returned per Dake's request, the RMA number must be clearly written on the exterior packaging. Any item shipped to Dake without an RMA will not be processed.



Warranty Exceptions:

The following conditions are not applicable to the standard limited warranty:

- (a) Part installation or machine service was not completed by a certified professional, and is not in accordance with applicable local codes, ordinances and good trade practices.
- (b) Defects or malfunctions resulting from improper installation or failure to operate or maintain the unit in accordance with the printed instructions provided.
- (c) Defects or malfunctions resulting from abuse, accident, neglect or damage outside of prepaid freight terms.
- (d) Normal maintenance service or preventative maintenance, and the parts used in connection with such service.
- (e) Units and parts which have been altered or repaired, other than by the manufacturer or as specifically authorized by the manufacturer.
- (f) Alterations made to the machine that were not previously approved by the manufacturer, or that are used for purposes other than the original design of the machine.

RETURN & REFUND POLICY

Thank you for purchasing from Dake! If you are not entirely satisfied with your purchase, we are here to help.

Returns

All Dake manufactured / distributed machines, parts and couplings include a 30-day return option. These policies are valid from the date of final shipment to the end user.

To be eligible for a return, the item must be unused and in the same condition as received.

All requested warranty claims must be communicated to the distributor or representative responsible for the sale. Once communication has been initiated, Dake Customer Service must be contacted for approval:

Phone: (800) 937-3253

Email: customerservice@dakecorp.com

Once the return request has been approved by Customer Service, a representative will supply a Return Material Authorization (RMA) number. The returned item must have the provided RMA number clearly marked on the outside packaging. Any item received without an RMA number clearly visible on the packaging will not be processed.

An RMA number can only be provided by the Dake Customer Service team and must be obtained prior to the return shipment.

Refunds

Once the item has been received and inspected for damages, a representative will notify the requestor referencing the provided RMA number.

If the return is approved, a refund will be issued to the original method of payment, less a 20% restocking fee. The restocking fee may be waived if an order is placed at the time of return with like-value merchandise.

Transportation costs are the responsibility of the end user and will not be credited upon return approval.

Any item that is returned after the initial 30 days or has excessive/obvious use will not be considered for a full refund.

SAFEGUARDING THE POINT OF OPERATION

ANSI B11.2 - Hydraulic Power Presses - Safety Requirements for Construction, Care, and Use

It is important that Dake press users have a clear understanding of their responsibility involving the care and use of their Dake hydraulic press, including point-of-operation safe guards. Dake strongly recommends that Dake press users obtain a copy of the current American National Standard Institute (ANSI) B11.2 standard, for a more complete understanding of their responsibilities.

ANSI B11.2 states the following, relative to point of operation safeguarding:

“Normally, only the employer (press user) can determine the requirements of the press productions system components, including the dies and methods for feeding. Therefore, the employer is ultimately responsible to designate and provide the point-of-operation safeguarding system.”

The standard also discusses additional responsibilities of the employer. Some of the key responsibilities are:

- The employer is responsible for the safety, use, and care of the hydraulic power press production system.
- The employer is responsible to consider the sources of hazards for all tasks to be implemented on the hydraulic power press production system.
- The employer is required to eliminate, or control identified hazards in the scope of their work activity.
- The employer is responsible for the training of personnel, caring for, inspecting, maintaining, and operating hydraulic press production systems to ensure their competence.
- The employer is responsible to provide and ensure that point-of-operation safeguarding is used, checked, maintained, and where applicable, adjusted on every production operation performed on a press production system.

A complete and current copy of the ANSI B.11.2 standard can be obtained by contacting the following:

American National Standards Institute
1430 Broadway
New York, NY 10018

AMT – The Association for Manufacturing Technology
7901 Westpark Drive
McLean, VA 22102

SPECIFICATIONS

Model	Force 10DA
Number	909205
Capacity	10 tons
Horse Power	1 HP
Voltage	110V Single Phase
Ram Travel	10"
Pressing Speed	20 ipm
Width between uprights	20"
Max. ram to table	40"
Height	80"
Base	29-3/4" x 24"
Weight	3,450 lbs.

In the space provided record the serial number and model number of the machine. This information is only found on the black and gold Dake tag shown below. If contacting Dake this information must be provided to assist in identifying the specific machine.



Serial No.	
Model No.	
Install Date:	

SAFETY



This is the safety alert symbol. When you see this symbol on your press be alert to the potential for personal injury.

Employer is responsible to perform a hazard/PPE assessment before work activity.

Label Placement View

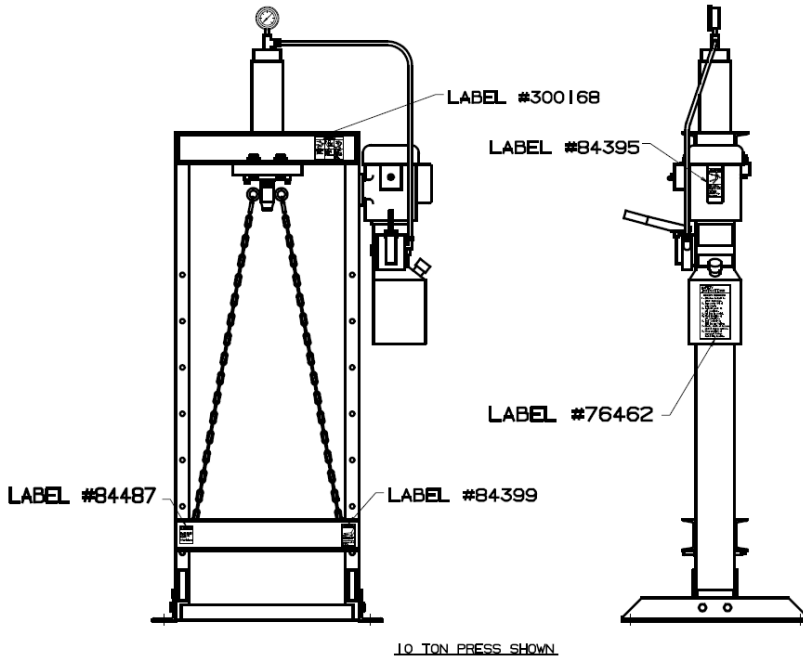

10 TON PRESS SHOWN



Label Part No. 300168



Label Part No. 76462



Label Part No. 84399



Label Part No. 302070



Label Part No. 84395



Label Part No. 84487

Follow recommended precautions and safe operating practices. It is important that the operator understand all safety instruction listed below in order to prevent damage to themselves, others, or the machine:

- Carefully read all the safety messages in this manual and on your press safety labels. Keep safety labels in good condition. Replace missing or damaged safety labels.
- Do not alter this press from its original design.
- Do not make repairs or adjustments to any hydraulic system unless you are competent or working under competent supervision.
- Only use Dake original parts.
- This machine is intended to be operated by one person. This person should be conscious of the ram movement not only for themselves but also for persons in the immediate area of the machine.
- This press is not intended for pulling operations. Personal injury or machine damage can result.

SET UP

PRESS PLACEMENT

- The press needs to be placed so that it has a safety perimeter of 2-1/2 feet on all sides from any other objects or machines.
- Press should be placed on level floor with base angles touching the floor at all points. Use shims where necessary.

FILLING THE PRESS WITH OIL

Fill the reservoir with DTE 24 Mobil hydraulic oil or equivalent.

- a. 10DA holds 2 gallons of oil. Make sure the oil is new and be cautious no contaminants get in while filling the reservoir.
- b. Oil should be changed about once a year.

WIRING INSTRUCTIONS

⚠ WARNING: A licensed qualified electrician that follows all state and local laws must wire and install electrics on this press.

110 Volt

⚠ WARNING: Machine must have a designated 30 amp drop for 110 volts. This press will not operate correctly without 30 amps.

For 110 volts this machine is ready to plug in. The machine can be wired 220-volt single phase. Always follow the wiring diagram provided in the moor cover when converting to 220-volt single phase. A cord and plug that is rated for a specific voltage and amperage must be used. This rating can be found on the motor.

220 Volt Single Phase

The press new is shipped out as a 110-volt machine. If wiring must be changed to suit 220-volt single phase.

1. The leads on the motor must be changed to fit 220-volt, 17.2 amps, follow the diagram on the motor.
2. Install plug and wire that fits the rating on the motor, the plug and wire must be rated for the voltage and amperage listed on the motor.

OPERATION

BEFORE FIRST TIME OPERATION

1. Make sure the reservoir is filled with 2 gallons of Mobil DTE 24 hydraulic fluid or equivalent.
2. Turn the on/off power (toggle) switch to the "on" position (up).
3. Move the control lever down, this will advance the ram in the downward position.
4. Release the control lever and the ram will stop all movement.
5. Move the control lever to the up position and the ram will move up.
6. When the press is new be sure to move the ram up and down to work out any air that may be in the system.

⚠ WARNING: When using the control lever in pressing operations or to return the ram stop applying pressure once the handle reaches its positive stop. Applying additional force on the lever does not increase ram speed and will lead to premature damage of the valve.

MAINTENANCE

LUBRICATION

Keep all working parts of press well oiled for easier operation. Also, keep a light film of oil over the entire surface of the ram to prevent rust.

HYDRAULIC LINES AND FITTINGS

If there is ever any maintenance done with the hydraulic components below is how to reinstall all components.

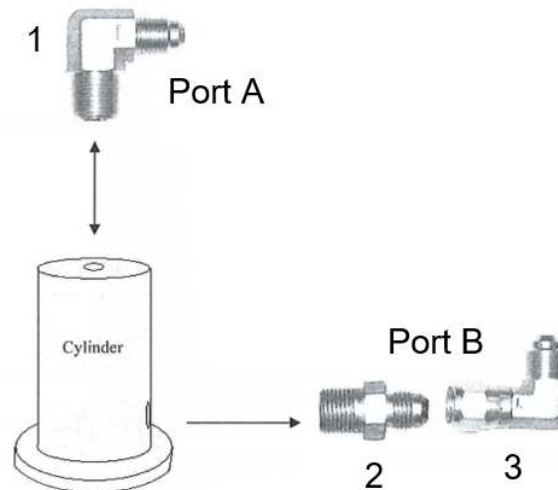

Item	Part No.
1	72050
2	73425
3	72047
4	302937
5	69671
6	72402
7	302183
8	302061
9	302224

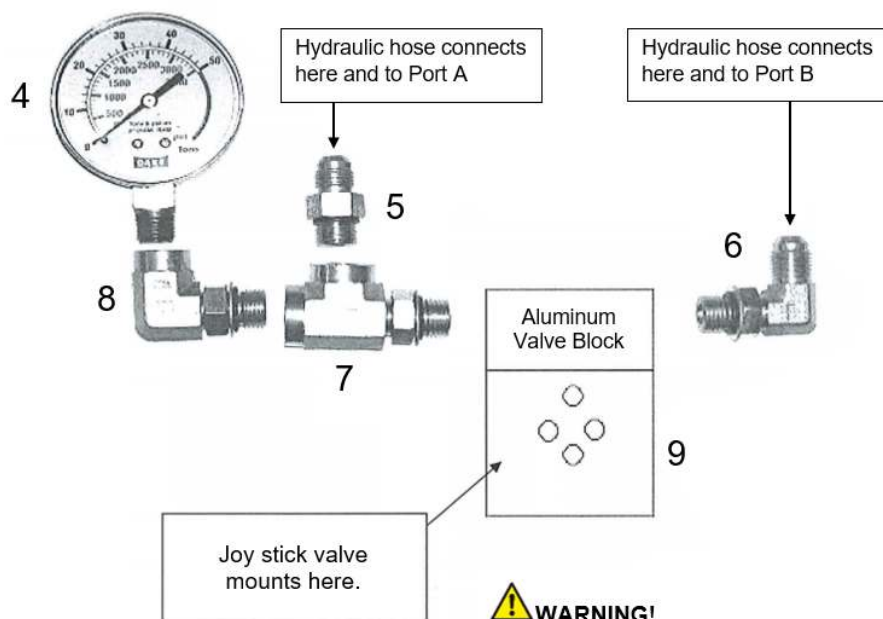

WARNING!

Be sure all fittings and bolts are tight.
Do not over tighten fittings or bolts.

TROUBLESHOOTING

SYMPTOM	CAUSE	SOLUTION
Ram runs jerky while moving up and down	Air is in the system	This press has a self-bleeding system, continue to run the ram up and down approximately 15 times.
Machine will not build desired pressure	Relief valve needs to be reset	Remove octane cap from back of manifold and adjust set screw to correct pressure. WARNING: Do not exceed 2413 PSI
Pins are shearing or bending	Relief valve needs to be reset	Remove octane cap from back of manifold and adjust set screw to correct pressure. WARNING: Do not exceed 2413 PSI
Oil Leaks around the ram	Cylinder seals are worn or damaged	Replace cylinder seals
Oil leaks around holes other than the ram	Bolts need to be tightened	Tighten bolts around the ram
Ram will not extend the full 10 inches	Oil level is too low	Re-fill the reservoir with oil
Hydraulic gauge will not read pressure	Hydraulic gauge is bad	Replace hydraulic gauge
Motor will not start	No power to press	Double check electrical cord
Motor overheats and shut down	Duty cycle time is exceeded	Check the duty cycle time on the motor. (Has no cooling fan, 15-20 minutes)
	Extension cord is being used	Extension cord will lower the APMS and will cause overheating of the motor. Remove cord.

EXPLODED VIEW & PARTS LIST

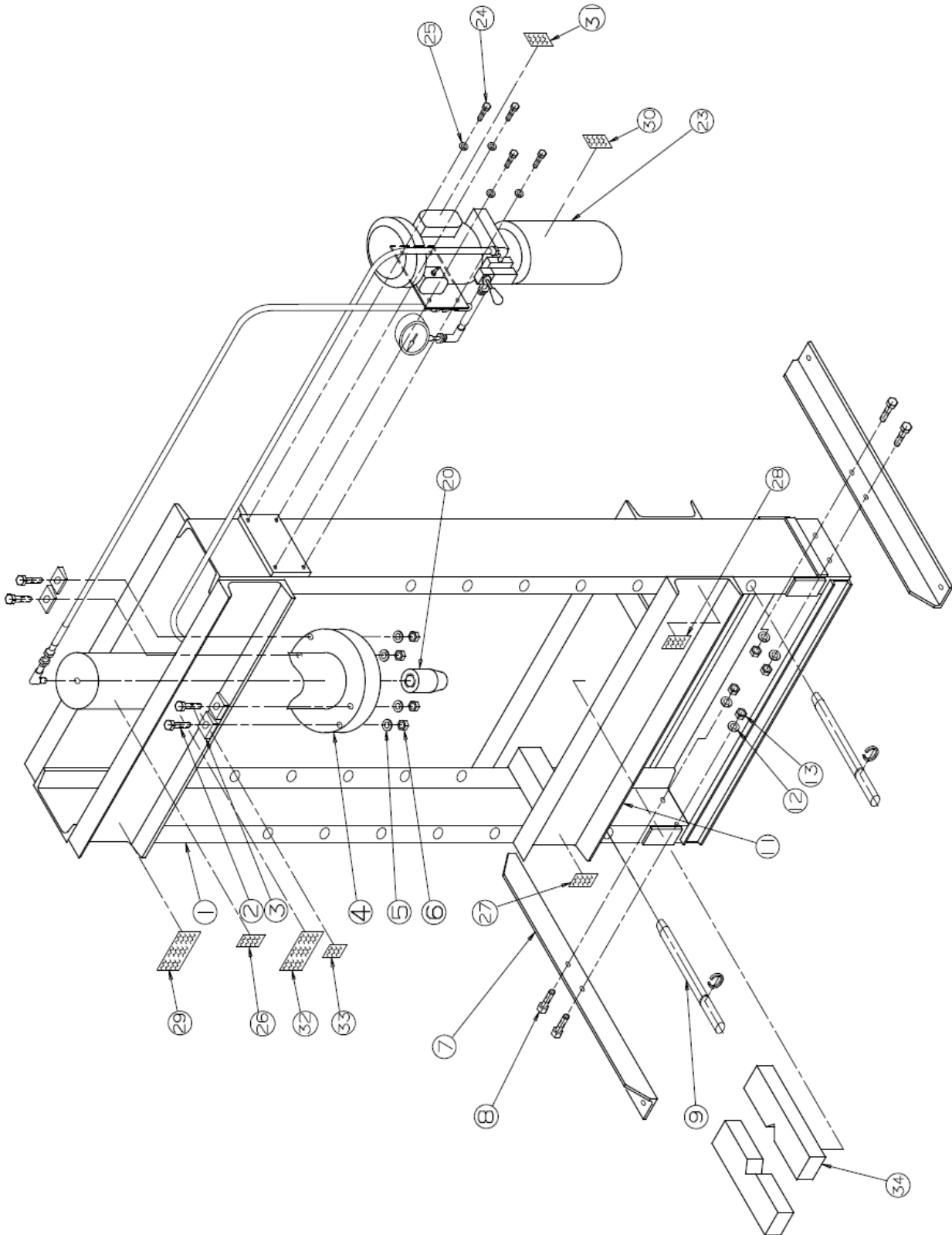

Item	Part Description	Part No.	Qty
1	Frame	86517	1
2	Hex Cap Screw (1/2"-13 x 2-3/4")	43355	4
3	Channel Washer	25H138	4
4	Workhead Assembly	716514	1
5	Lock Washer (1/2")	43647	4
6	Hex Nut (1/2"-13)	43916	4
7	Base Angle	85189	2
8	Hex Cap Screw (1/2"-13 x 1-1/2")	43349	4
9	Table Pin	86520	2
11	Table Channel	86692	1
12	Lock Washer (1/2")	43647	4
13	Hex Nut (1/2"-13)	43916	4
20	Nose Piece	86691	1
23	Hydraulic Power Unit	300266PU	1
24	Bolt (5/16"-18 x 1")	43315	4
25	Flat Washer (5/16")	43632	4
27	Warning Label	84487	1
28	Warning Label	84399	1
29	3-IN-1 Warning Label	300168	1
30	Safety Instructions	76462	1
31	Warning Label	84395	1
32	DAKE Name Plate	81002	1
33	Made in USA Plate	76936	1
34	Table Plates	85427	2

PARTS NOT ILLUSTRATED			
Item	Description	Part No.	Qty
Breather Vent & Elbow	Reservoir fill port	300267	1
Gauge	Tons/PSI	302937	1
Reservoir	2 Gallons	300269	1
Valve Kit	Fittings, hoses, valve, manifold, bolts, & O-rings	300266KIT	1
Optional Check Valve		302071	1
Optional Relief Valve	290-3625 PSI or 20-250 Bar	301949	1
Optional Relief Valve	43.5-435 PSI or 3-30 Bar	302197	1
Bolts SHC #10-24 x 1-3/4"	Mounting bolts for valve only	43403	4
Bolts SHC #10-24 x 2-3/4"	Mounting bolts for valve, relieve valve, or check valve	76749	4
Bolts SHC #10-24 x 4-1/2"	Mounting bolts for valve, relieve valve, or check valve	302221	4

10 DA WORKHEAD DIAGRAM

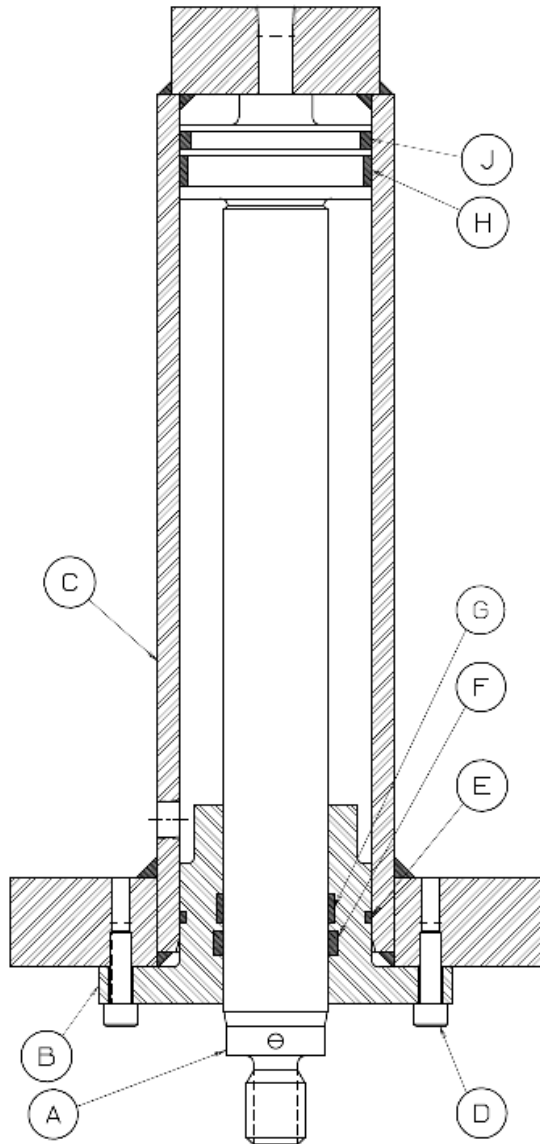

Item	Description	Part #
A	Piston	86690
B	Cylinder Flange	86689
C	Cylinder	86688
D	Socket Head Cap Screw	43450
E	O-Ring	78483
F	Seal	78484
G	Wear Ring	78485
H	Wear Ring	78486
J	O-Ring Seal	78487
-	Workhead Assembly	716514

10 Ton DA Workhead Specs

3-1/4" Dia. Bore

1-3/4" Dia. Rod

10-1/4" Actual Stroke

10" Rated Stroke

66 lbs. Total Weight

Please contact factory for current prices.

ORDERING INFORMATION

Parts are available for direct purchase from Dake or through a distributor. When placing a parts order, you will need to provide the part number, name of part, and model number. All parts shipped F.O.B. Factory in Grand Haven, MI.