



103E5

*Electronic Timeswitch
for Controlling Hot Water and Heating
(Including Factory Replacement Units FRU)*

Index

Installation

Product specification	3
Installation	4-6
Wiring	6-9
Replacement	10-11

User

What is a timeswitch	12
Your timeswitch	13
Setting the clock	14
Factory preset programmes	15
Setting the programme - 24 hour	16
Setting the programme - 5/2 day	17
Running the programme	18
Temporary user overrides	19
Battery backup	20
Contact details	24



Certification Mark

This product complies with the following EC Directives:
Electro-Magnetic Compatibility Directive.
(EMC) (2004/108/EC)
Low Voltage Directive.
(LVD) (2006/95/EC)



Danfoss can accept no responsibility for possible errors in catalogues, brochures, and other printed material. All trademarks in this material are property of the respective companies. Danfoss and the Danfoss logotype are trademarks of Danfoss A/S. All rights reserved.

Installation Instructions

Please Note:

This product should only be installed by a qualified electrician or competent heating installer, and should be in accordance with the current edition of the IEEE wiring regulations.

Product specification

Specification	
Power supply	230 Vac \pm 15%, 50 Hz
Switching action	1 x SPST, Type 1B
Switch rating	264 Vac, 50/60Hz, 3(1)A
Timing Accuracy	\pm 1 min./month
Power Reserve	Minimum 14 days
Enclosure Rating	IP30
Max. Ambient Temperature	45°C
Dimensions, mm (W, H, D)	102 x 136 x 47
Design standard	EN 60730-2-7
Control Pollution Situation	Degree 2
Rated Impulse Voltage	2.5kV
Ball Pressure Test	75°C

Installation

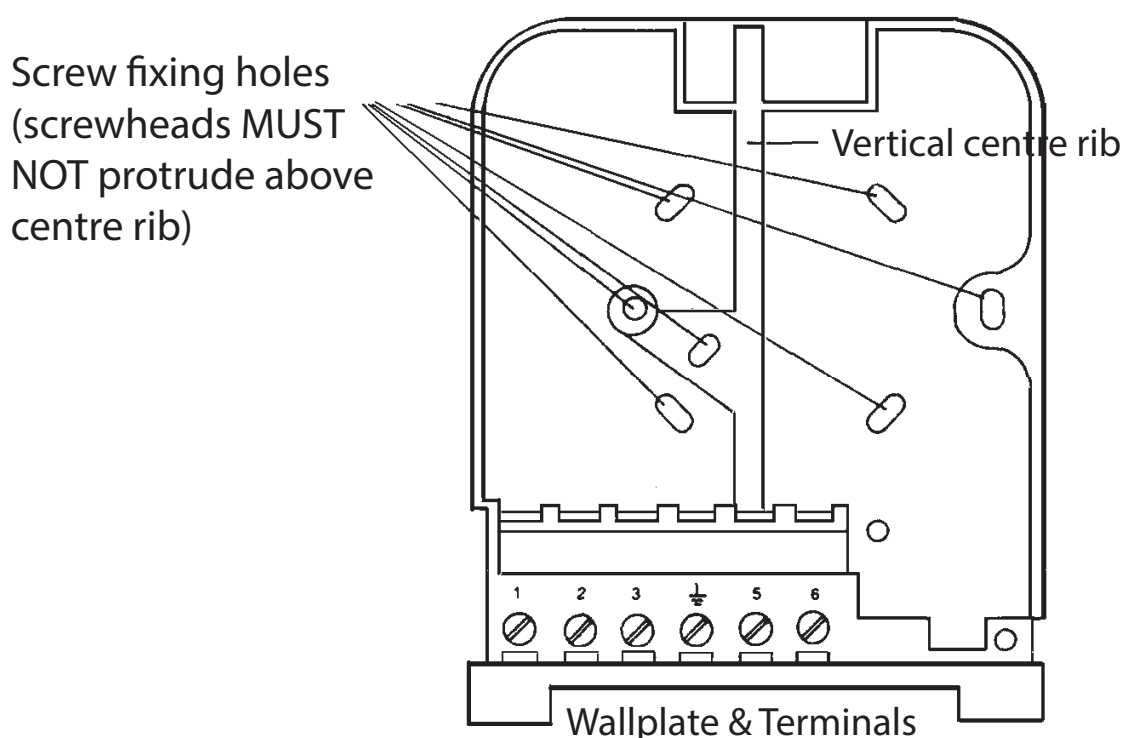

NB. For FRU units - go straight to point 6.

1. Loosen the fixing screw in the base of the unit to release the Wiring Cover.
2. Holding the unit face downwards, press firmly in the centre of the wallplate and slide it apart and lift it from the module.
3. Fix the wallplate and terminal block to the wall, or plaster box, as required. Ensure that the screw heads do not protrude beyond the vertical centre rib of the wallplate, or this will prevent the module correctly locating onto the wallplate.



4. Surface cables can only enter from below the unit. Cut an appropriate cable aperture in the wiring cover. If the wallplate is mounted on a plaster box, cables can enter from the rear below the terminal block.

- Electrical connections are simplified by using a Wiring Centre. However, if this is not used, the wallplate terminal identification is as shown.

LOAD			Mains Supply (via 3 amp. fuse)		
ON	SPARE	COM		N	L
1	2	3		5	6

If the system being controlled is 230 Vac then terminals 3 and L must be linked with insulated cable capable of carrying full load current. Whilst the unit does not require an earth connection, a terminal is provided on the wallplate for earth continuity purposes.

- Referring to the wiring diagrams on page 6-9, connect the unit as shown.
- Find out from the user whether the unit is required to operate in 24-hour mode (factory preset) or weekday/weekend mode (5/2 day). To convert to 5/2 day mode remove the small two-way connector from the pins towards the left of the recess on the rear of the module, then press the **SELECT/ADVANCE/+/-** buttons all at the same time to RESET the unit.
- Ensure all dust and debris are cleared from the area. Plug the module into the wallplate by locating it onto the wallplate and, when flush with it, sliding it down, ensure the hook at the top of the wallplate engages with the slot at the back of the module.
- Before setting the programme, check the unit and circuit. Press the **SELECT** button until the bar in the display lines up with the word **ON**. Adjust the remote thermostats to check the system operates correctly.

10. Then press the **SELECT** button until the bar lines up with the word **OFF** and check the system does not operate.
11. When the circuit check has been completed, replace the wiring cover and tighten the fixing screw. Cut any cable aperture in the wiring cover which may be necessary to accommodate surface mounted cables.
12. Finally set time of day and programmes required, noting that the unit is supplied with a pre-set programme, as stated on Page 14.

Wiring

Wiring

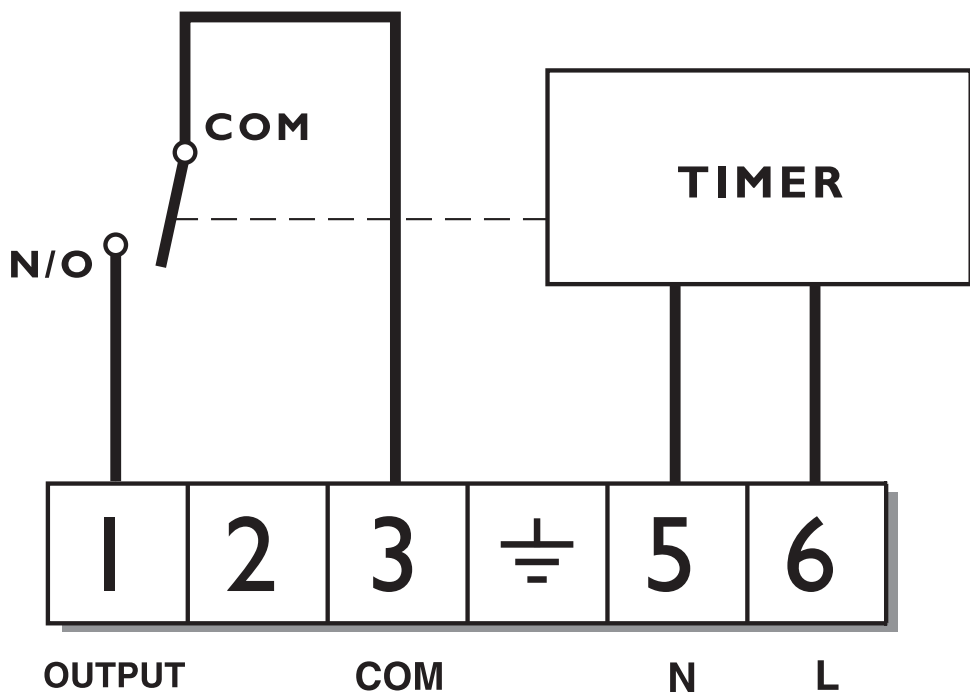

103, 103E5

Typical Gravity DHW with pumped heating

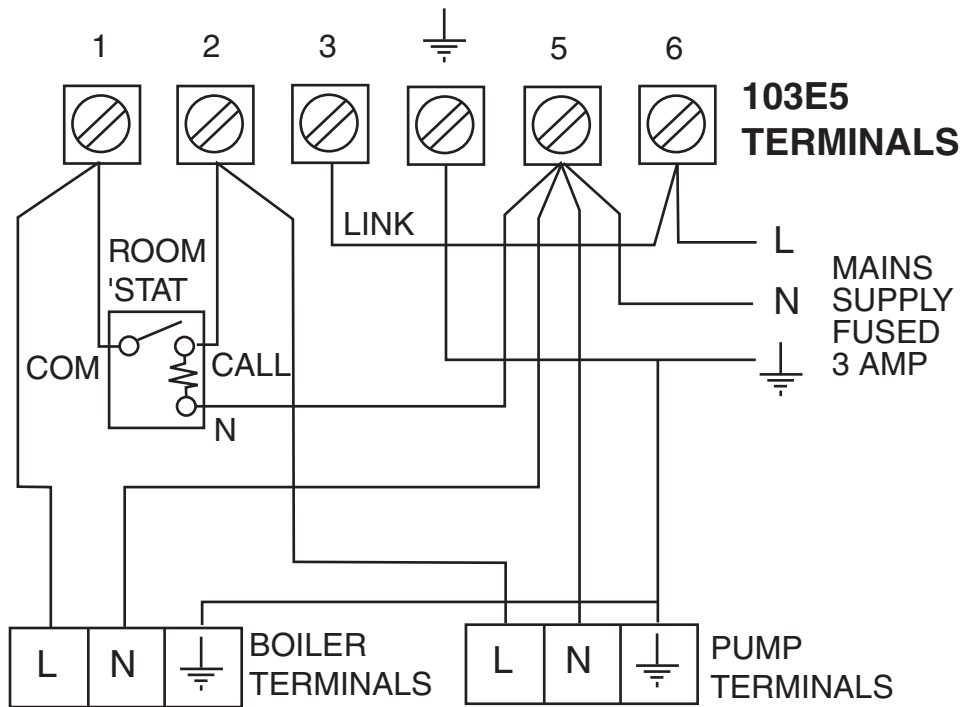

Typical control of Pump for Central Heating on a Solid Fuel System

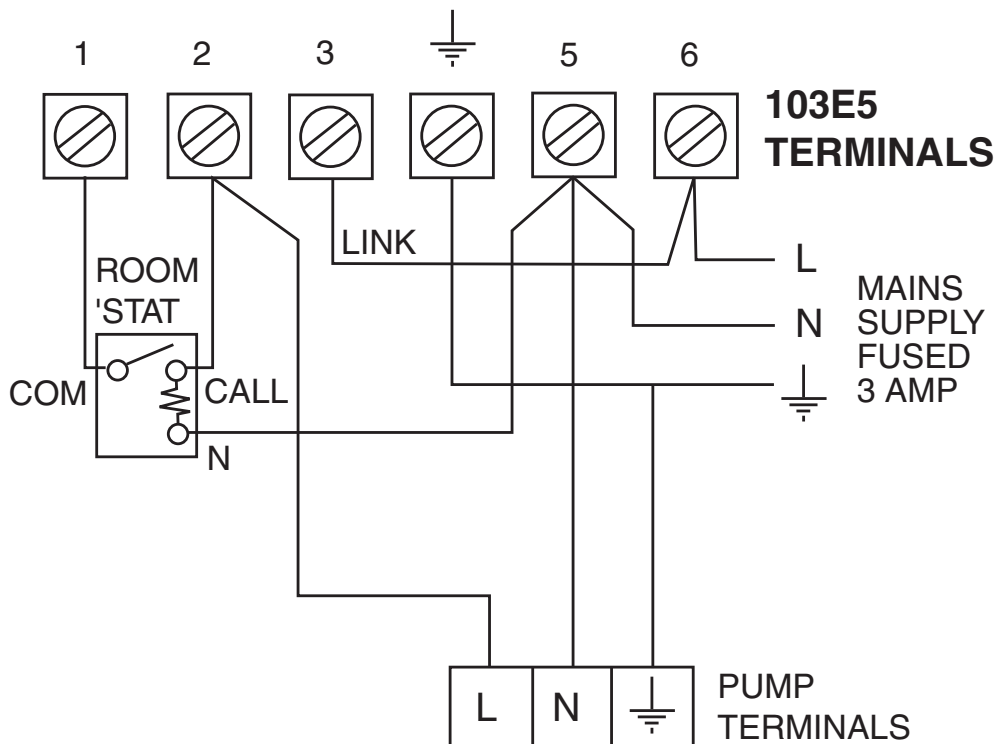

Typical Heating Only system, Boiler and Pump control

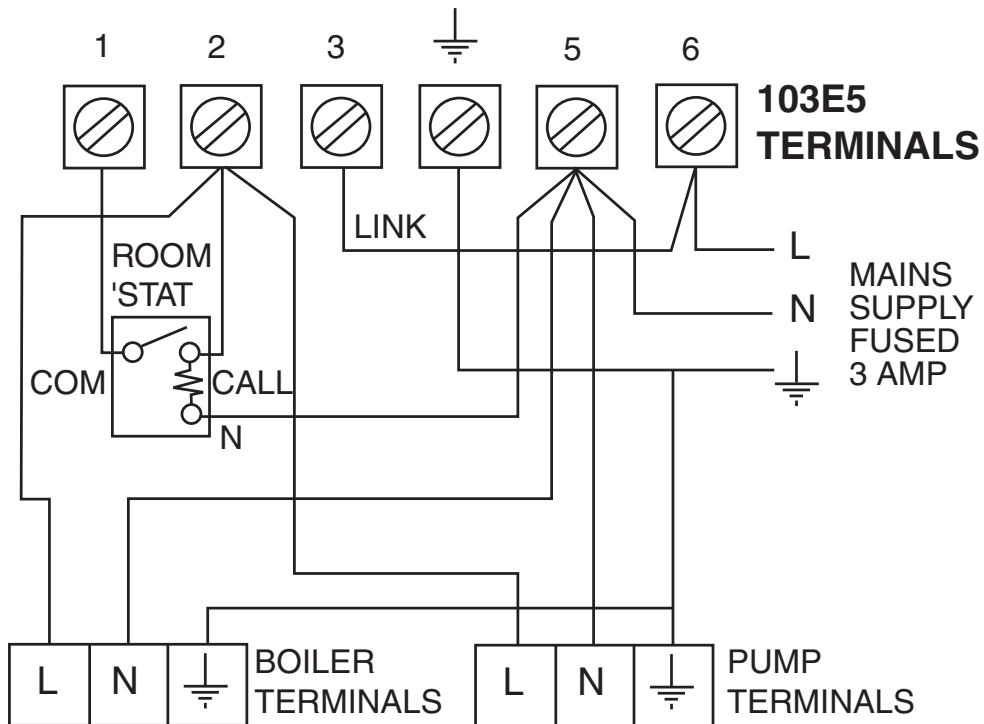

Typical control of Low Voltage System requiring voltage free contacts

Wiring

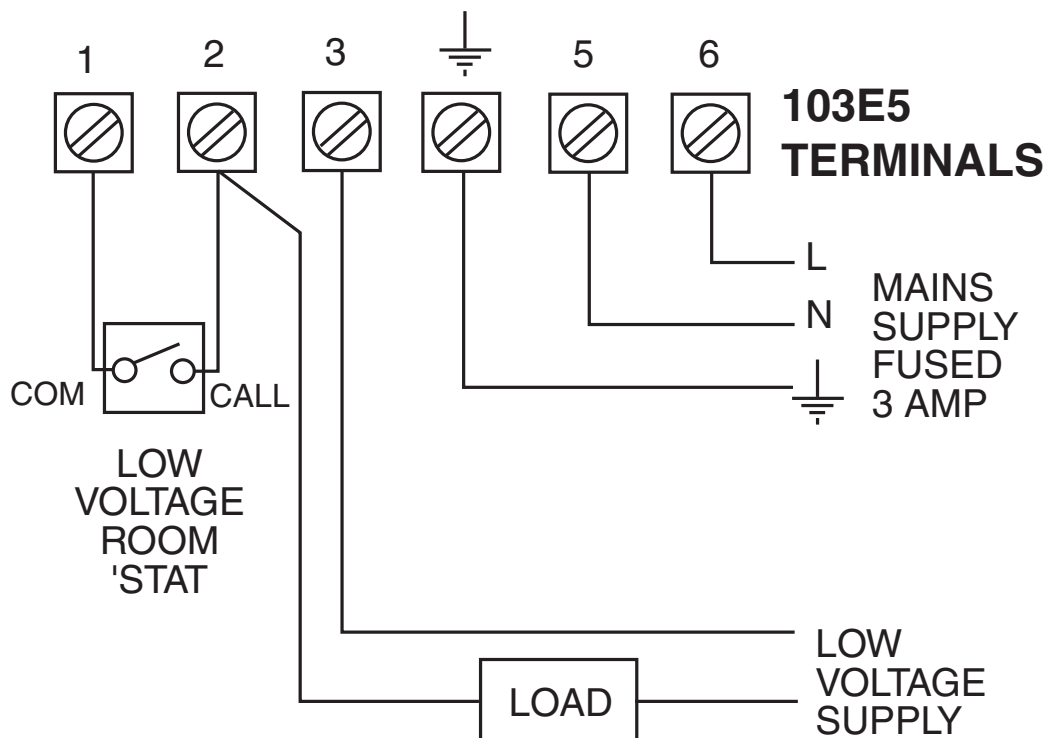



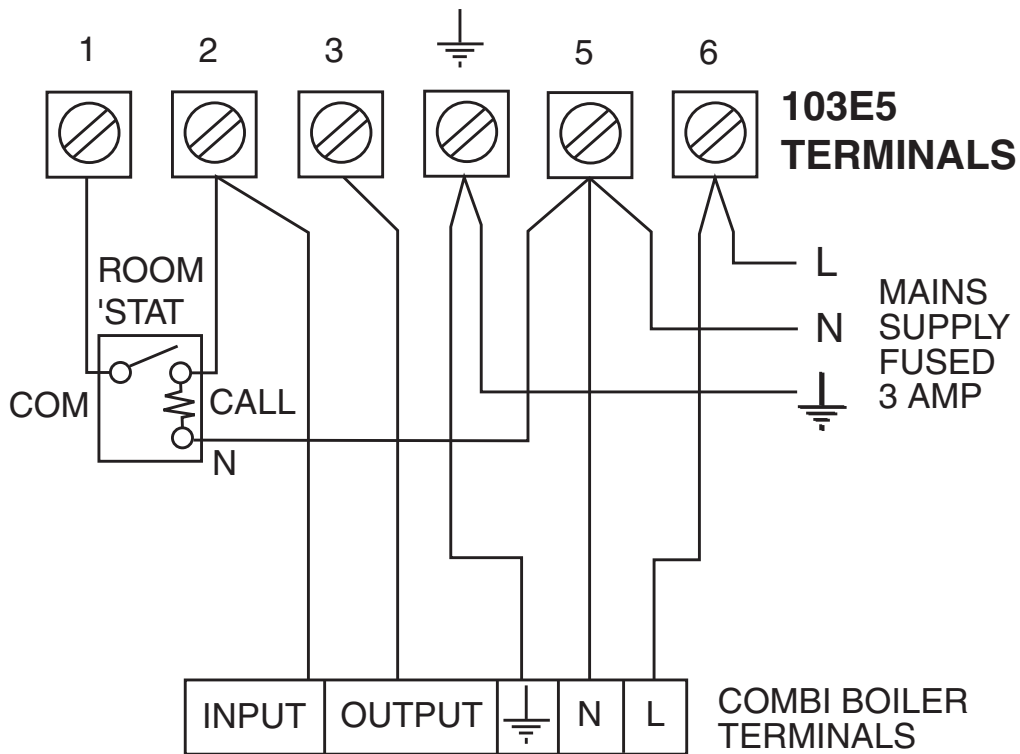



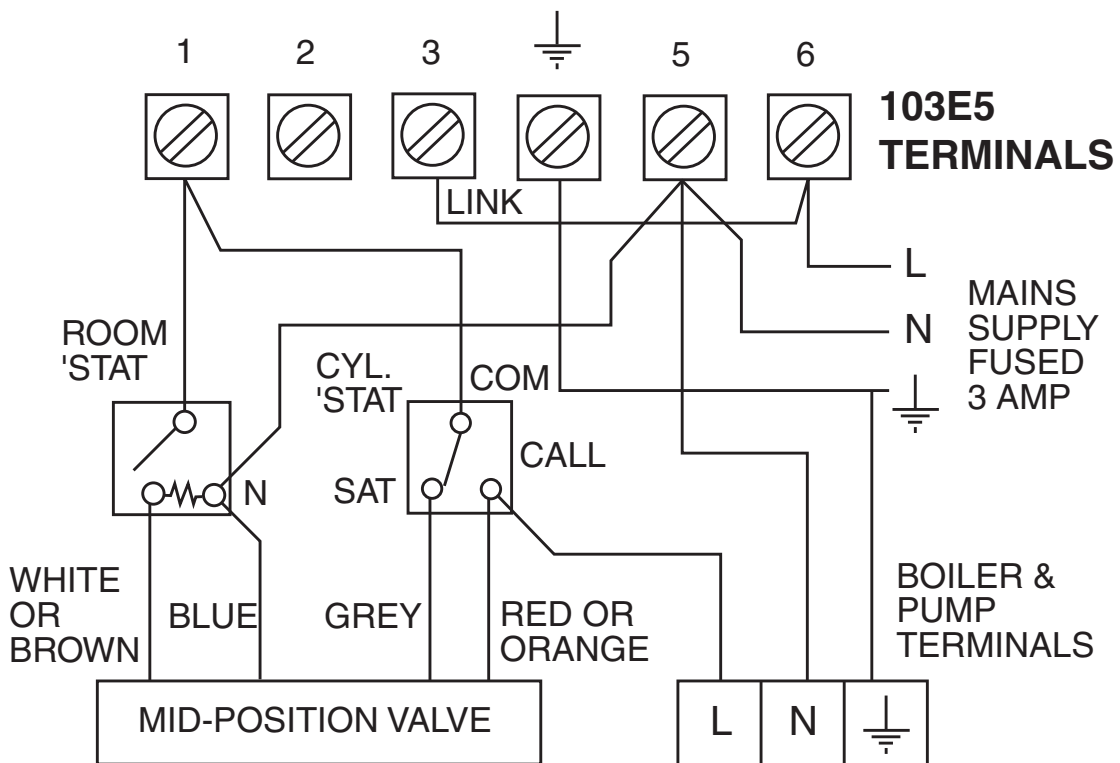





Typical control of Heating when provided by Combination type Boiler









Typical Heating & Hot Water control system using 3 port mid-position valve



Replacement

DANFOSS RANDALL 103E5	LOAD			MAINS SUPPLY (via 3 amp fuse)	An additional terminal block is required where these discon- nected leads (or pairs of leads) should be terminated					
	ON	SPARE	COM		5 (N)	6 (L)	A	B	C	D
	1	2	3		5 (N)	6 (L)	A	B	C	D
RANDALL 103, 103E, 103E7	1	2	3		5	6				
RANDALL 3020	4	2	-		1,7	6	3	5		
RANDALL TSR2	4	5	-		3	1,2	6	7		
GRASSLIN 45, 45A, 45E	4	-	3		2	1				
HORSTMANN 424 EMERALD & PEARL AUTO RANGE	4	2	3		N	L,1	5			
HORSTMANN 423 PEARL, EMERALD & TOPAZ	4	1	3		N	L	2	5	6	
SANGAMO S254 Form 2S408 Form 5, S251 Form 2	LOAD	-	-		N	L				
SANGAMO S610 F2, S611 F2, S612 F2, S408 F4, S408 F6, S253 F2, S255 F2	LOAD	-	SWITCH LIVE		N	MO- TOR LIVE				
SANGAMO S409 Form 8	2	1	6		3,N	5,L				
SANGAMO/RANDALL SET 1	4	2	5		N	L				
SMITHS IND. MKI, MKII	P3	P1	P2		N	L				

SMITHS IND. CENTROLLER 30	4,5	3	-		1	2	6			
SMITHS IND. CENTROLLER 40	4,5	3	-		1	2				
SWITCHMASTER 300	1	2	4		N	L	3			
TOWERCHRON TC	7	3	4		2	1	8	9	10	11
VENNER VENNERETTE MKIHA	LOAD	-	LINE		N	L				
VENNER VENNERETTE MKIVA	1	-	4		2	3				
VENNER VENNERON VEN- NERON P	4	-	1		3	2				

TACMA

THE ASSOCIATION
OF CONTROLS
MANUFACTURERS



The text below has been edited and approved by the Plain English Campaign, who has issued a Crystal Mark to be displayed with it.

What is a programmer?

... an explanation for householders.

Programmers allow you to set 'On' and 'Off' time periods. Some models switch the central heating and domestic hot water on and off at the same time, while others allow the domestic hot water and heating to come on and go off at different times.

Set the 'On' and 'Off' time periods to suit your own lifestyle. On some programmers you must also set whether you want the heating and hot water to run continuously, run under the chosen 'On' and 'Off' heating periods, or be permanently off.

The time on the programmer must be correct. Some types have to be adjusted in spring and autumn at the changes between Greenwich Mean Time and British Summer Time.

You may be able to temporarily adjust the heating programme, for example, 'Override', 'Advance' or 'Boost'. These are explained in the manufacturer's instructions.

The heating will not work if the room thermostat has switched the heating off. And, if you have a hot-water cylinder, the water heating will not work if the cylinder thermostat detects that the hot water has reached the correct temperature.

Please note: A timeswitch is a single channel programmer. It will allow you to set your system's On and Off periods.

User Instructions

Your timeswitch

Your 103E5 timeswitch controls your hot water and heating together, turning them on and off at the same times.

The 103E5 can provide 3 ON periods and 3 OFF periods each day and can offer either 24 hour control (same programme for each day of the week) or 5/2 day control (one set of programmes for weekdays and a different set for weekends)

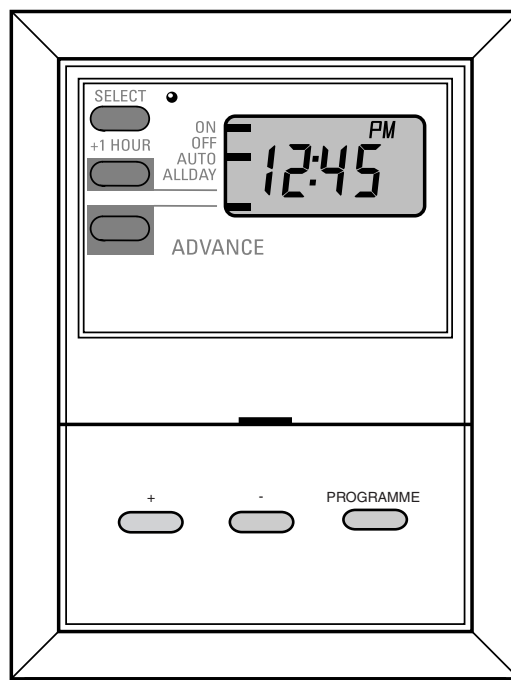

Before you start

- Open the flap on the front of the unit.
- Press all four buttons (**SELECT / ADVANCE / + / -**) at the same time

This will reset the unit, reinstate the preset programmes and set the time to 12:00pm on Monday.

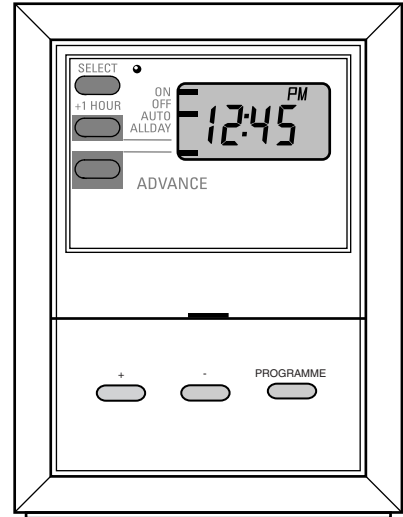

Setting the clock

- Press **PROGRAMME** once
- Use **+** and **-** buttons to set the correct time
- When time is correct press **PROGRAMME** again.

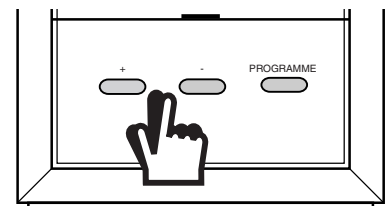
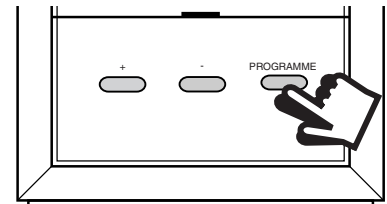

In **24 hour mode** this will take you straight to programming mode, where you can select your own ON and OFF times.

In **5/2 day mode** this will first allow you to programme the correct **DAY**. To do this:

- use the **+** or **-** buttons to select the correct day
- press **PROGRAMME** again to enter RUN mode

Factory Presets

The unit is supplied with the following preset programme which will be active after the unit has been reset.

	Mon-Fri or All days in 24hr mode	Sat-Sun* (5/2day mode only*)
1st ON	6.30am	7.30am
1st OFF	8.30am	10.00am
2nd ON	12.00pm	12.00pm
2nd OFF	12.00pm	12.00pm
3rd ON	5.00pm	5.00pm
3rd OFF	10.30pm	10.30pm

N.B. 2nd ON and 2nd OFF are set to the same time. These 2 times are ignored by the programme therefore the heating will just come on once in the morning and once in the evening. If you want the heating to come on in the middle of the day set the 2nd ON and 2nd OFF to the times you require.

Accepting the preset times

If you are happy to use the settings above, you don't need to do anything else.

To accept the presets press the **PROGRAMME** button until the colon in the display begins to flash.

Your unit is now in **RUN** mode.

Programming event times in 24 hour mode

You can programme your timeswitch to come on and go off up to 3 times each day, to suit your requirements.

- Press **PROGRAMME** until 1 (Event 1) shows along the top of the display.
- Use the + **and** - buttons to set the time you want your system to first come on in the morning
- Press **PROGRAMME** again to move to the next step (Event 2)
- Use the + **and** - buttons to set the time you want your system to first go off.
- Continue using the **PROGRAMME** and +/- **buttons** in this way to set the ON/OFF times for events 3-6 (2nd ON/OFF & 3rd ON/OFF).



N.B. It is not possible to programme times out of sequence.

If you do not press a button at all for 3 or 4 minutes the unit will automatically return to RUN mode.

Programming event times in 5/2 day mode

You can programme your timeswitch to come on and go off up to 3 times each day, to suit your requirements, with one set of programmes for weekdays and a different set of programmes for the weekend.

Weekdays (MOTUWETHFR)

- Press **PROGRAMME** until 1 (Event 1) shows along the top of the display and **MOTUWETHFR** shows along the bottom.
- 
- The image shows a digital display with the number '1' in the top left corner. The time '6:30' is displayed in large digits, with 'AM' in smaller letters above the '0'. Below the time, the schedule 'MOTUWETHFR' is shown.
- Use the **+** and **-** buttons to set the time you want your system to first come on in the morning.
 - Press **PROGRAMME** again to move to Event 2
 - Use the **+** and **-** buttons to set the time you want your system to first go off.
 - Continue using the **PROGRAMME** and **+/- buttons** in this way to set the ON/OFF times for events 3-6 for weekdays.

Weekend (SASU)

- Press **PROGRAMME** again until 1 (Event 1) shows along the top of the display and **SASU** shows along the bottom of the display.
- 
- The image shows a digital display with the number '3' in the top left corner. The day 'SAT' is shown in the top right. The time '10:30' is displayed in large digits. Below the time, the schedule 'SASU' is shown.
- Use the **PROGRAMME** and **+/- buttons** to set the ON/OFF times for the weekend.

If at any time you wish to return to the factory preset programme, press **SELECT / ADVANCE / + / -** buttons together at the same time to reset the unit.

N.B. It is not possible to programme times out of sequence.

Running your programme

The 103E5 controls your hot water and heating together, turning them on and off at the same times.

To run the central heating and hot water programme press the **SELECT** button.

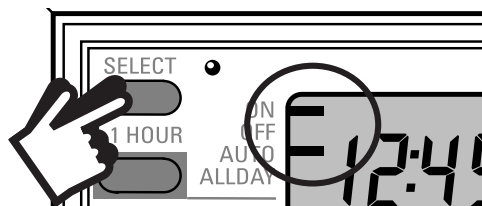

As you press **SELECT** a bar on the display will move between **ON**, **OFF**, **ALLDAY** and **AUTO**

RUN mode

- **ON** = the hot water/heating will remain on constantly
- **OFF** = the hot water/heating will not come on
- **AUTO** = the hot water/heating will come on and go off according to the programmed times
- **ALLDAY** = the unit will come on at the first programmed ON and will remain on until the last programmed OFF

Select the option you require, depending on your circumstances, time of year, etc.

Temporary User Overrides

Sometimes you may need to change the way you use your timeswitch temporarily, i.e due to unusually cold weather. The 103E5 has two convenient overrides which can be selected without affecting the set programme.

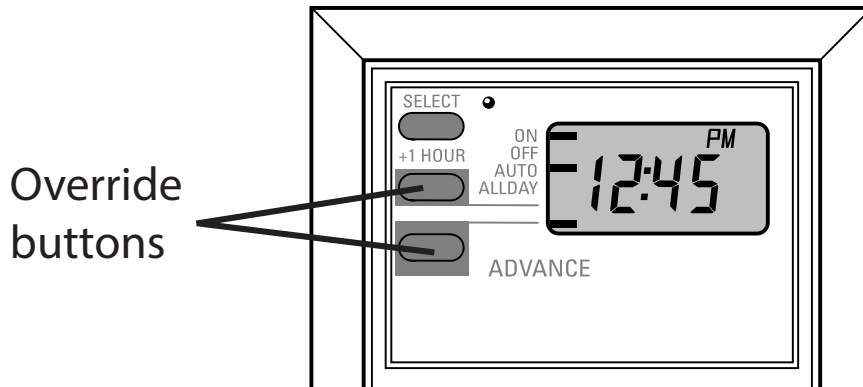

+1HOUR

- Press **+1HOUR** once if you need **an extra hour of operation**

If the system is off it will come on for an hour. If it is already on it will add an extra hour so the system stays on for an extra hour.

To cancel the override press +1HOUR again.

ADVANCE (only during AUTO mode)

- Press the **ADVANCE** button once to **advance to the next programmed event.**

If the system is on it will go off. If it is off it will come on. The set programme will resume at the next programmed ON/OFF time.

To cancel the override press ADVANCE again.

Battery backup

In the event of a power cut, the built-in lithium battery will keep your time and programme settings for up to 15 days.

After 15 days without mains power the unit will switch off and two dots will show in the display. However all your programmed on/off times will be remembered.

When the mains power is restored, the unit will need to be reactivated by pressing the **PROGRAMME** button, and the time and day will need to be set (see page 14).



Still having problems?

Call your local heating engineer:

Name:

Tel:

For problems relating to your heating controls ...

Visit our website:

www.heating.danfoss.co.uk

Email our technical department:

ukheating.technical@danfoss.com

Call our technical department

01234 320 256

(9:00-5:00 Mon-Thurs, 9:00-4:30 Fri)

**For a large print version of these instructions
please contact the Marketing Services
Department on 01234 364 621.**

Danfoss Randall Ltd

Ampthill Road

Bedford

MK42 9ER

Tel: 01234 364621

Fax: 01234 219705