

ENGINEERING
TOMORROW

Danfoss

User Guide

Vickers by Danfoss
PVM Variable Displacement Piston Pump
Design Code B

Up to 315 bar
98/106 cc/rev
(6-6.5 in³/rev)
Variable Speed Drive Ready

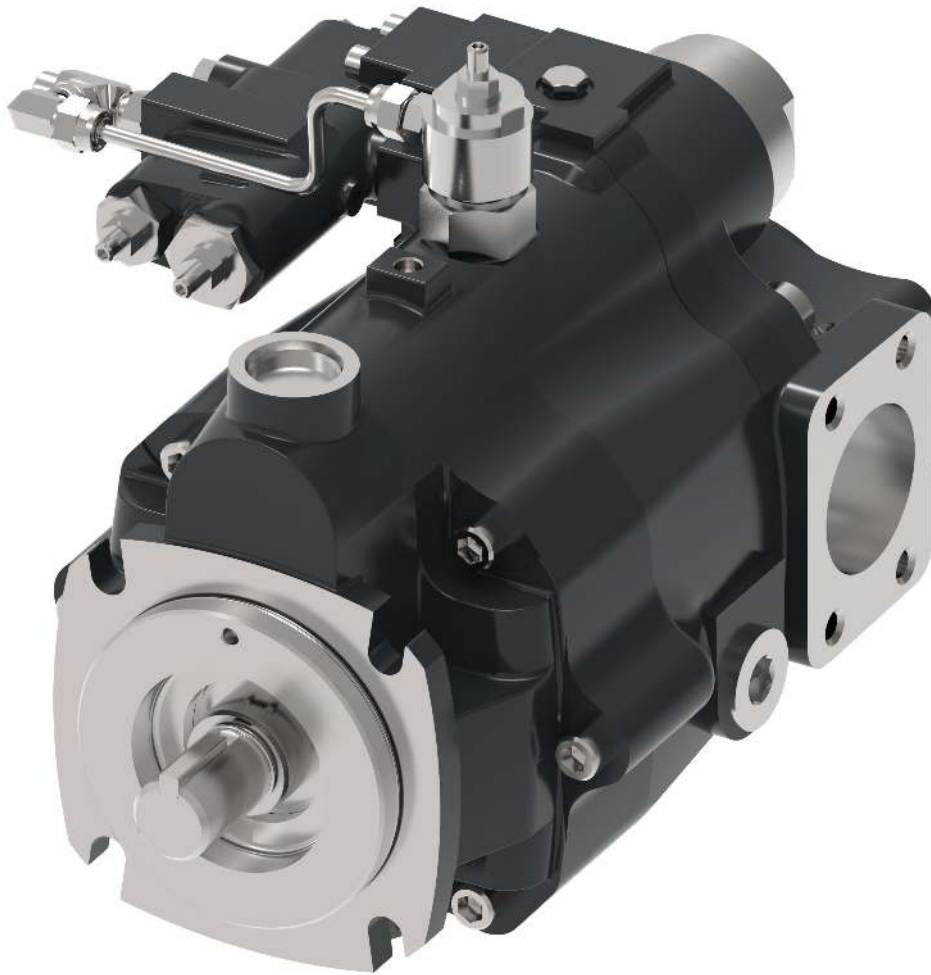

VICKERS
by Danfoss

BC488979909885en-000102

Vickers by Danfoss | Industrial PVM Variable Displacement Piston Pumps

Table of Contents

M Series Variable Displacement Piston Pumps

Introduction	3
Model Code Selection	4
Specifications and Performance	5
Control Options	7
Performance	12
Dimensions	22
Mounting Flange Options	28
Shaft Options	29
Input Shaft Selection Data and Port Options	30
Operating Requirements	31
Alternate Fluids Guide	32
Installation and Start-up	33

Introduction

Vickers by Danfoss M Series pumps are open circuit, axial piston designs. A variety of control options allows the pumps to perform most efficiently in a specific application. Efficiency of the pump controls allows down-sizing of system cooling needs, saving up front cost in the machine. Alternatively, cooling capacity could be kept the same and the flow capability of the system increased, thus improving performance and customer satisfaction.

The M Series also contains a strong proven rotating group allowing the pumps to handle pressures up to 315 bar (4568 psi) continuous with less maintenance cost. High-load carrying capacity bearings and a stiff drive shaft help provide very long life at rated industrial conditions, reducing operating costs and extending operating life.

M Series pumps feature a saddle-type yoke with steel-backed polymer bearings. The stiff yoke reduces deflection and allows even loading of bearings, improving life. A single control piston reduces loading on the yoke, resulting in reduced pump size which allows installation in tighter locations.

M Series pumps operate at a level of quietness that exceeds the requirements of today's demanding work conditions. The pumps feature a unique three-piece envelope (flange, housing and valve block) specifically created for low fluid-borne and structure-borne noise levels. Another pump feature – a bimetal timing plate – improves pump filling characteristics which, in turn, reduce fluid-borne noise and extend pump life.

M Series pumps reduce, or in some cases remove, the need for damping barriers between the noise source and the operator. This saves money on the installed cost of the system while improving customer comfort.

An adjustable maximum stop provides a means of tuning flow to your system, while gauge ports allow monitoring of inlet and outlet conditions. These standard features reduce system complexity and cost.

Mounting flange is offered in SAE configurations, and ports are offered in SAE flange versions.

Side ported models are available to facilitate plumbing and help fit the pump to your machine space needs. Multiple drain ports allow many mounting orientations, reducing installed costs.

M Series pumps are capable of operating with many types of hydraulic fluids used in industrial systems. High-water-content and phosphate ester fluids can be accommodated, in addition to the typical petroleum based and synthetic fluids.



Typical Applications

- Mining machinery
- Injection molding machines
- Metal forming machines
- Oil and Gas Equipment
- Conveyor lines
- Primary metals
- Metal cutting equipment

Features and Benefits

- Tear drop shaped housing contains fluid borne sound and reduces operator fatigue
- Standard adjustable maximum volume screw and gage ports give the ultimate in flexibility to the engineer or service technician
- High overall efficiency reduces operating costs
- Robust shaft bearings extends operating life and lowers maintenance costs
- Multiple port types and locations aid in flexibility of machine design
- Very low pressure ripple reduces shock in the system resulting in less leakage

Model Code Selection

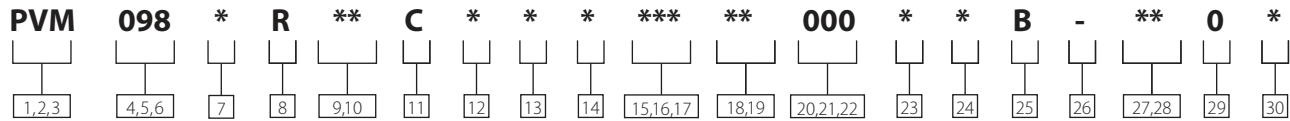

1,2,3 Product Series

PVM – M Series Variable Piston Pump

4,5,6 Displacement

098 98.3 cm³/r [6.00 in³/r] (315 bar Max)

106 106.5 cm³/r [6.50 in³/r] (230 bar Max)

7 Valve Plate

E - Industrial -1800 rpm max

M - Higher speed version.

8 Input Rotation

R – Clockwise (Right hand)

L – Counter-clockwise (Left hand)

9,10 Input Shaft

09 - SAE J744-32-1 SAE C Straight Keyed

10 - SAE J744-38-1 SAE C-C Straight Keyed

11 - SAE J744-32-4 SAE C 14T Spline

12 - SAE J744-38-4 SAE C-C 17T Spline

24 - 31.8 [1.25] Dia Tapered Keyed Shaft .750-16 UNF-2A External Thread Key Included

11 Mounting Flange

G – SAE J744-127-4 C 4-Bolt

12 Main Port Location

S – Side Ported

13 Main Port Type

2 - SAE J518 Flange Ports SAE Auxiliary Ports

14 Control

0 - None

A - Pressure Compensator

B - Pressure and Flow Compensator with Bleed Down Orifice

C - Pressure and Flow Compensator with Plugged Orifice

E - Industrial Control (Pressure and flow compensated)

F - Industrial Control (Pressure compensated)

L - Power Control/Torque Limiter

15,16,17 Pressure Compensator Setting

000 - None

070 - 070±4 bar [1015±58 lbf/in²] [Default]

230 - 230±4 bar [3335±58 lbf/in²] [Default for 106 cc/r]

315 - 315 bar [4567 lbf/in²] [Default for 98cc/r]

18,19 Flow Compensator Setting

00 – None

11 – 11 bar setting

20 – 20 bar setting

20,21,22 Power control Torque Limiter Setting

000 – None

050 – Limited to 50 kW*

(Adjustable From 20-90 % Of

Rated Torque, * For Any Other

Values Specify Power in kW,

Available in Increments Of 5 kW)

23 Auxiliary Mounting Pad

0 - None (Non-Through Drive)

1 - Auxiliary SAE A-Mount with

Cover Plate and No Coupler

A - SAE A 2-Bolt 9T Spline

B - SAE A 2-Bolt 11T Spline

C - SAE B 2-1/4-Bolt 13T Spline

D - SAE B-B 2-1/4-Bolt 15T Spline

E - SAE C 2-1/4-Bolt 14T Spline

F - SAE C-C 2-1/4-Bolt 17T Spline

24 Paint

0 – No paint

A – Standard black paint

25 Design Code

B – B

26 Differentiator

- -

27,28 Pump Special Features

00 – Adjustable Max Displacement Stop

29 Compensator Special Features

0 – None

(Contact Danfoss for options)

30 Customer Identification

0 – None

(Contact Danfoss for options)

Specifications and Performance

Quiet version, optimized for 1000-1800 rpm (E)

Displacement, Pressure and Flow Ratings At 50°C (120°F), SAE 10W oil, 1 bar absolute (0 psig) inlet

Model Series	Geometric Displacement cm ³ /r (in ³ /r)	Maximum Pressure bar (psi)		Maximum Flow at 315 bar (4500 psi)			
		Nominal	Peak**	@1800 r/min	@1500 r/min	@1200 r/min	@1000 r/min
PVM098	98,3 (6.00)	315 (4568)	350 (5000)	170 (45)	141 (37)	112 (29.6)	92 (24.3)
PVM106	106,5 (6.50)	230 (3300)	280 (4000)	187 (49)	155 (41)	123 (32)	102 (27)

**Less than 0.5 second.

Speed, Input Power and Torque Ratings At 50°C (120°F), SAE 10W oil, 1 bar absolute (0 psig) inlet

Model Series	Maximum Operating Speed r/min	Maximum Input Power at 280 bar (4000 psi) kw (hp)*@88% M.E.				Max torque at 280 bar (4000psi) Nm (lb-ft)r/min	Approx Wt kg (lb)
		@1800r/min	@1500 r/min	@1200r/min	@1000r/min		
PVM098	1800	88 (118)	72 (97)	58 (78)	48 (64)	464 (342)	55 (121)
PVM106	1800	72 (97)	60 (80)	48 (64)	40 (54)	383 (282)	55 (121)

Standard Response Times*

Model Series	On Stroke (msec)	Off Stroke (msec)
PVM098	65	25
PVM106	72	29

*Values with pressure compensator control.

High speed version (M)

Displacement, Pressure and Flow Ratings At 93°C (200°F), SAE 10W oil, 1 bar absolute (0 psig) inlet

Model Series	Geometric Displacement cm ³ /r (in ³ /r)	Maximum Pressure bar (psi)		Maximum Flow at 315 bar (4500 psi)
		Nominal	Peak**	Flange Ports l/min (USgpm) @ 1 bar inlet
PVM098	98,3 (6.00)	315 (4568)	350 (5000)	200 (53) @ 2200 r/min
PVM106	106,5 (6.50)	230 (3300)	280 (4000)	222 (59) @ 2200 r/min

**Less than 0.5 second.

Speed, Input Power and Torque Ratings At 93°C (200°F), SAE 10W oil, 1 bar absolute (0 psig) inlet

Approximate Model Series	Operating Speed and Pressure r/min		Max. Input Power at	Max. Torque at	Weight (dry) kg (lbs)
	1 bar Inlet Flange Ports	0,85 bar Inlet Flange Ports	Max. Speed and 280 bar (4000 psi) kW (hp)	280 bar (4000 psi) Nm (lb-ft)	
PVM098	2200 r/min		105 (141)	457 (337)	55 (121)
		1800 r/min	86 (115)	457 (337)	55 (121)
PVM106	2200 r/min		87 (117)	377 (278)	55 (121)
		1800 r/min	70 (94)	377 (278)	55 (121)

Standard Response Times*

Model Series	On Stroke (msec)	Off Stroke (msec)
PVM098	85	24
PVM106	90	25

*Values with pressure compensator control.

Specifications and Performance

Variable Speed Drive

Variable Speed Performance- System Pressure vs Speed

Model Series	Max Speed "E"*(rpm)	Max Speed "M"*(rpm)	Min Speed (rpm)	Nominal Pressure (bar)	Peak Pressure (bar) **	Inertia (kg-cm ²)
PVM098	1800	2200	0	315	350	131.6
PVM106	1800	2200	0	230	280	122.7

* Valve plate type

**Less than 0.5 second.

Note - For Variable Speed Drive applications, Modelcode Position 14 should be set at 0 and position 15, 16, 17 should be set to 000 to configure pump to "Fixed Displacement" type.

Moment of Inertia (single pump rotating group)

Model	Moment of Inertia	
	N-m (sec ²)	lbf-in (sec ²)
PVM098	0.0132	0.1165
PVM106	0.0123	0.1086

PVM System Pressure vs. Shaft Speed

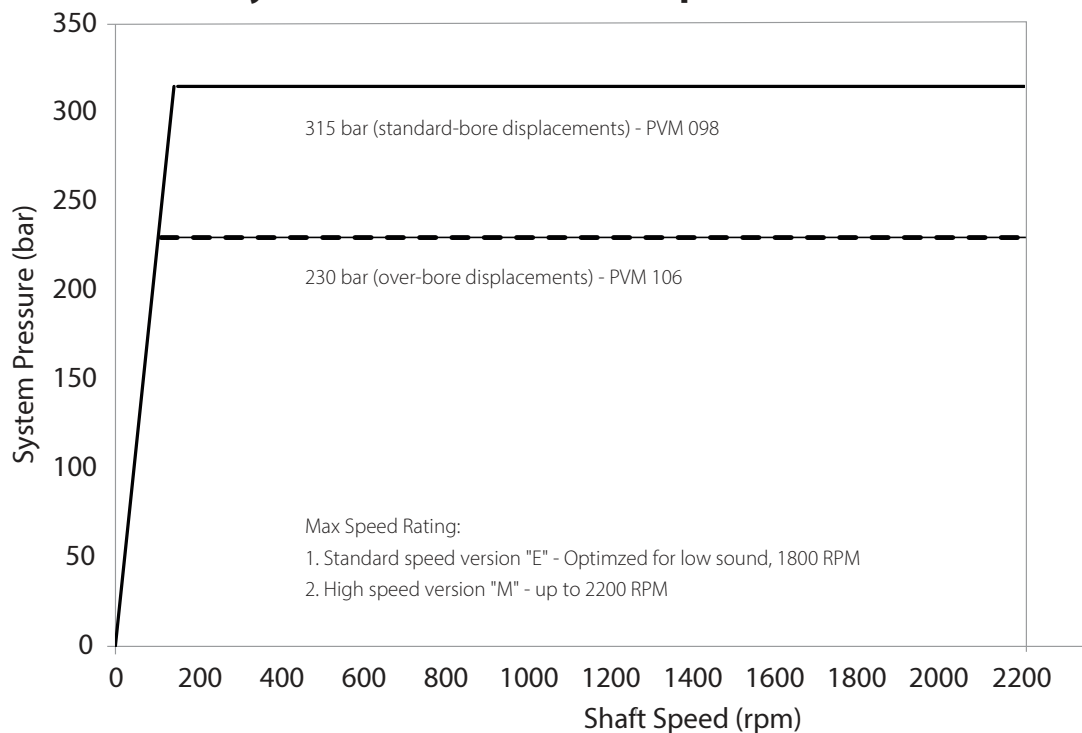

Test condition: Mineral oil SAE 10W, oil temperature 49° C (120° F), 1 bar absolute inlet pressure.

Control Options

Pressure Compensator Control – Code A

The pump will provide a continuously modulated flow to meet changing load demands at a pre-adjusted compensator pressure. At pressures below the compensator setting, the pump will operate at maximum displacement.

Warning: The pressure compensator may be adjusted beyond the rated pressure of the pump. When adjusting the pressure limiter, install a 0-350 bar (0-5000 psi) gage in the outlet gage port and limit the pressure setting to the continuous rated pressure for the pump displacement.

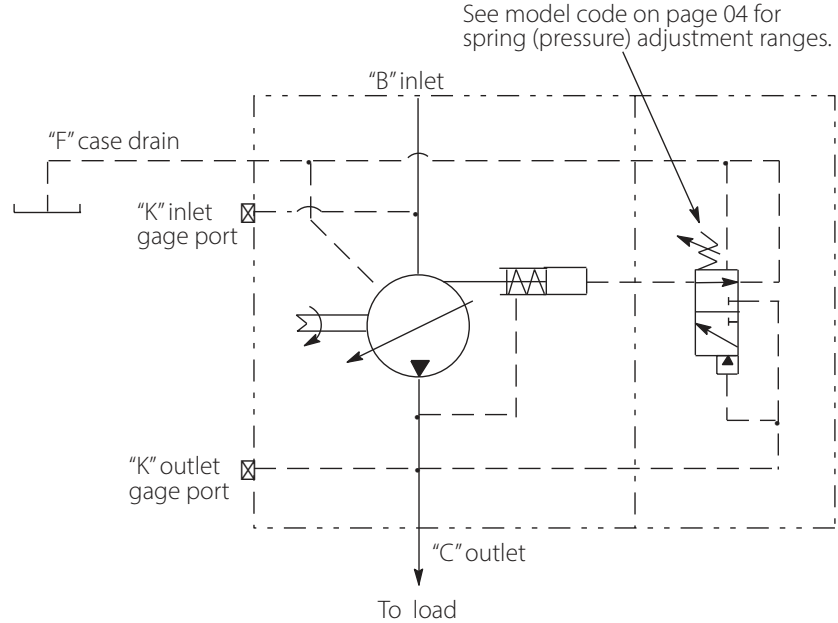

Pressure Cut-off Characteristics of Pressure Compensator Control

Industrial: at 50°C (120°F), Static conditions

Mobile: 93°C (200 °F), Static conditions

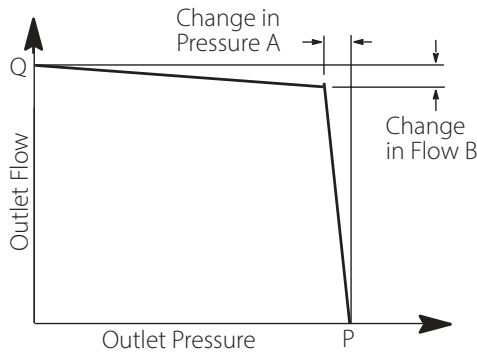

Pressure Cut-off Characteristics of Pressure Compensator Control @ 50°C (120°F), Static Conditions

Model Series	Max. Speed r/min	"Q" Outlet Flow l/min (USgpm)	"P" Outlet		
			Pressure bar (psi)	A bar (psi)	B L/min (USgpm)
PVM098	1800	179 (47)	315 (4568)	1,5 (22)	25 (6.6)
PVM106	1800	195 (51.5)	230 (3300)	1,5 (22)	20 (5.3)

Pressure Cut-off Characteristics of Pressure Compensator Control @ 93°C (200°F), Static Conditions

Model Series	Rated Speed r/min	"Q" Outlet Flow l/min (USgpm)	"P" Outlet		
			Pressure bar (psi)	A bar (psi)	B L/min (USgpm)
PVM098	2200	217 (57)	315 (4568)	1,5 (20)	32 (8.4)
PVM106	2200	234 (62)	230 (3300)	1,5 (22)	24 (6.33)

Control Options

Load Sensing and Pressure Compensator Control – Code B or C

The pump will provide power matching of pump output to system load demand, maximizing efficiency and improving load metering characteristics of any directional control valve installed between the pump and the load.

Load sensing ensures that the pump always provides only the amount of flow needed by the load. At the same time, the pump operating pressure adjusts to the actual load pressure plus a pressure differential required for the control action. When the system is not demanding power, the load sense control will operate in an energy-saving stand-by mode.

Typically, the differential pressure is that between the pressure inlet and service port of a proportionally controlled directional valve, or a load sensing directional control valve.

If the load pressure exceeds the system pressure setting, the pressure compensator de-strokes the pump. The load sensing line must be as short as possible and can also be used for remote control or unloading of the pump pressure. For remote control purposes, it is recommended that you contact your Danfoss representative for the correct configuration of the control.

⚠ Warning: The pressure compensator may be adjusted beyond the rated pressure of the pump. When adjusting the pressure limiter, install a 0-350 bar (0-5000 psi) gage in the outlet gage port and limit the pressure setting to the continuous rated pressure for the pump displacement.

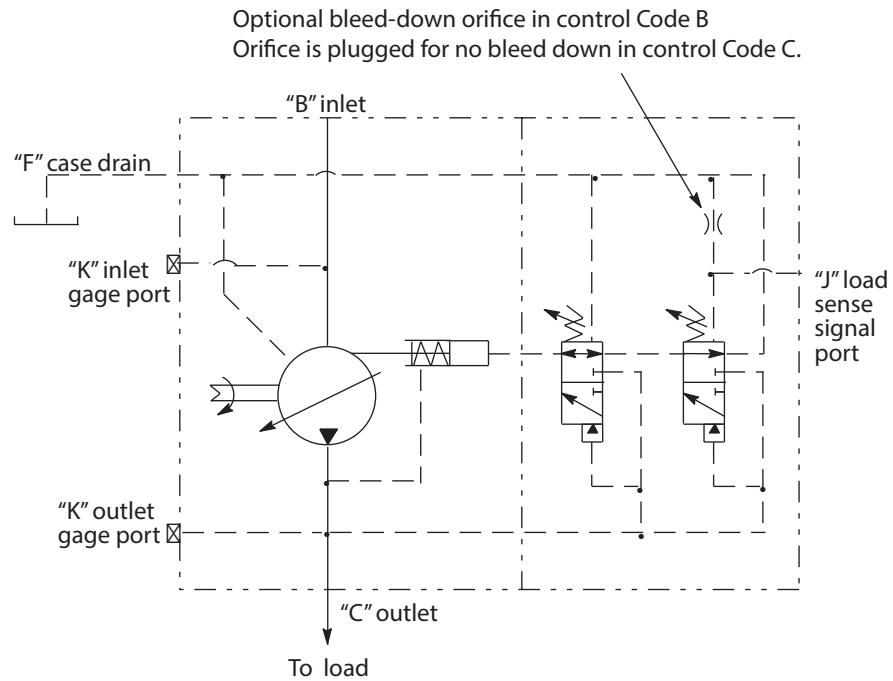

Control Options

Industrial Control Compensator – Code E and F

This pump is intended for use when multiple, remote, or electronically controlled compensating settings, with or without load sensing, are desired.

Pressure compensation is obtained when an internal plug is removed, the load-sense signal port is kept plugged, and internal pilot pressure is applied to the spring chamber of the control spool. For pressure compensation with load sensing, the internal plug stays, the load-sense signal port is unplugged, and pilot pressure is externally applied.

An external relief valve (not supplied) controls spring chamber pressure. The externally adjustable spring determines the differential pressure setting of the control. Outlet pressure is limited to the valve of the spring chamber (pressure port) pressure, plus control differential pressure.

Spring chamber (pilot) pressure is separated from outlet pressure by an internal orifice. Outlet pressure shifts the spool when pressure drop across the orifice reaches the differential pressure setting, and the pump de-strokes.

The relief valve can be mounted to an NFPA-D03/ISO 4401-03 pad on the pump control, or remotely located via tapping and blanking plates installed on the pad.

The standard factory-set differential pressure setting of the pump control is 20 bar (290 psi) and is not specified in the pump model number. Any other ordered differential pressure, within the control's adjustable pressure range of 17-35 bar (247-508 psi), will be specified in the model number.

With Pressure & Flow Compensator (E)

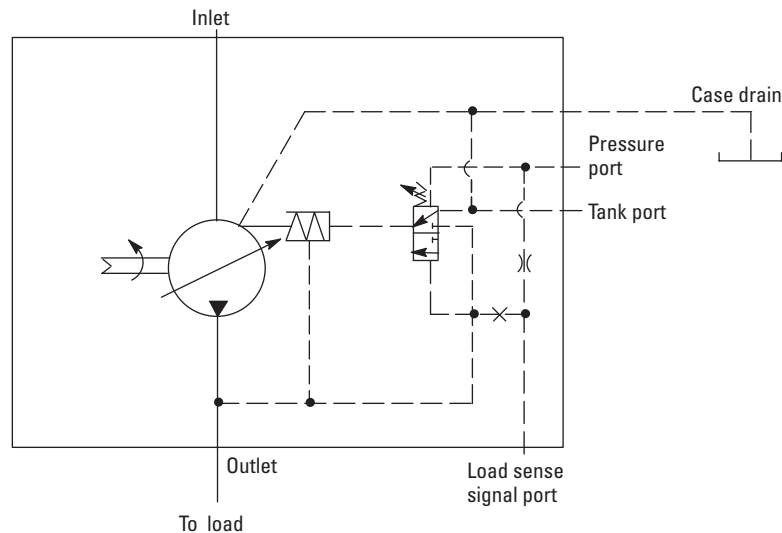

Pressure Compensating without Load Sensing (F)

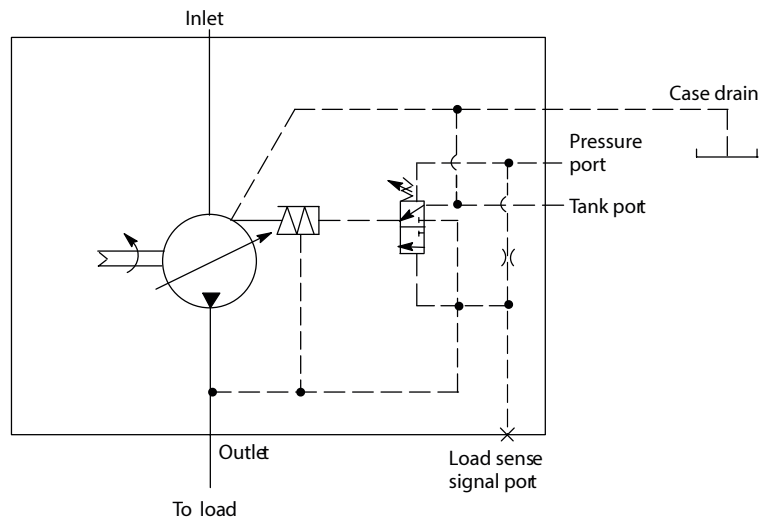

Control Options

Power Control - Code L

The Power control limits the maximum torque output by the piston pump by reducing the displacement as pressure increases hence limiting the power rating at a given speed.

As pressure increases the pump displacement is reduced such that the set torque value is not exceeded.

The torque can be set between 20-90% of rated torque for given displacement at 1500 rpm.

⚠ Warning: The pressure compensator may be adjusted beyond the rated pressure of the pump. When adjusting the pressure limiter, install a 0-350 bar (0-5000 psi) gage in the outlet gage port and limit the pressure setting to the continuous rated pressure for the pump displacement shown on page 7.

Note:

If the application runs at a different speed, for example 1800 rpm, and the power should be limited to 50 kW then use this formula:

$$(50 \text{ kW}) / (1800 \text{ rpm}) \times 1500 \text{ rpm} = 41.66 \text{ kW}$$

Then round off to the next available model code i.e., 045.

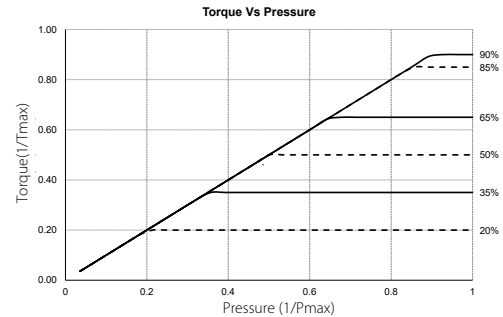
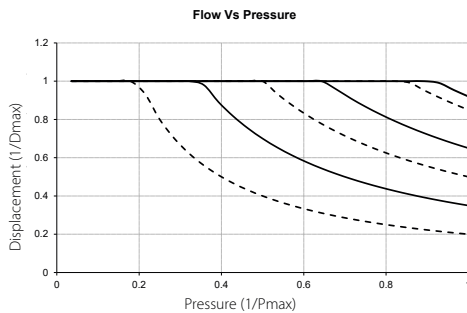
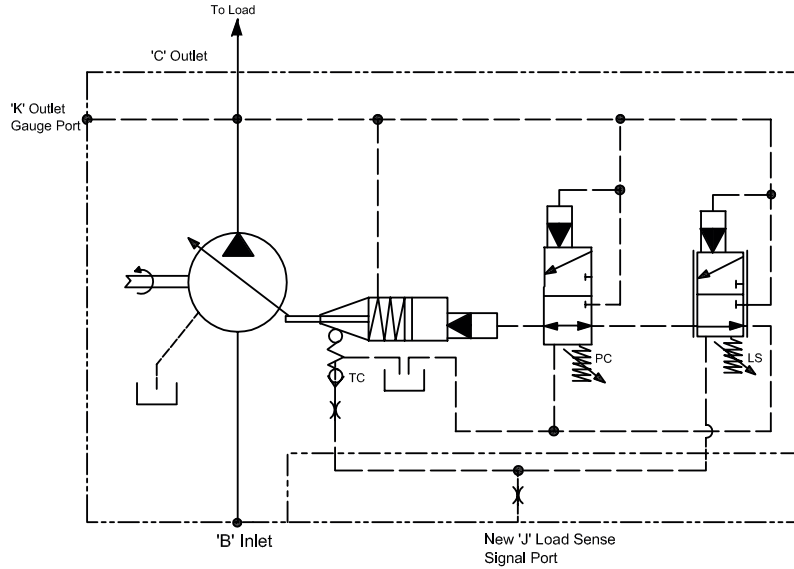

Characteristics of Code L Power Control at 50°C (120°F), static conditions.

Torque setting range by displacement

Displacement (cc)	Rated Torque lb-in (N-m)	Min torque setting lb-in (N-m), 20% of rated torque*	Max torque setting lb-in (N-m), 90% of rated torque
098	4346 (491)	869 (98.2)	3912 (442)
106	3434 (388)	690 (78)	3089 (349)

* For Minimum torque setting (20%) the pump may not deliver the flow at higher pressure. Please contact Danfoss Engineering for flow generated at max pressure

Control Options

Operation and installation - Power Control / Torque Limiter

Description

PVM series piston pump with Power Control consists of, A) pump with modified pressure and flow compensator and B) Power Control subassembly installed.

Pump with Power limiter control

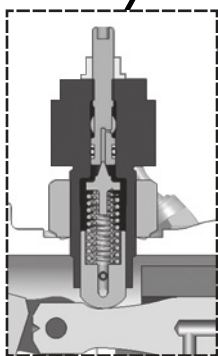
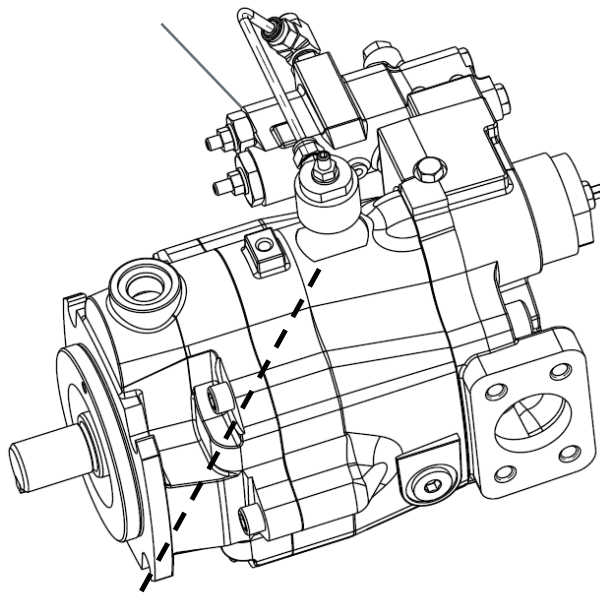

Power control S/A

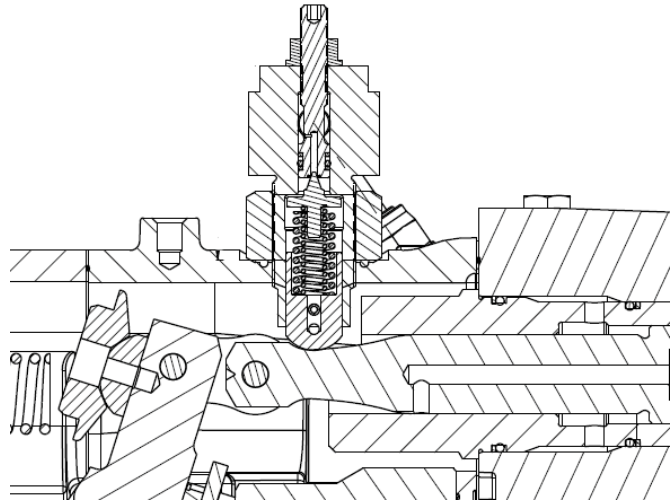
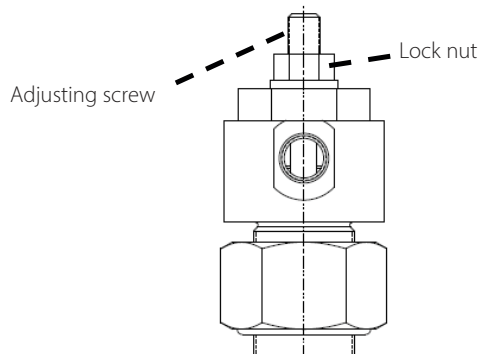

Power Control Operation

The Power Control Subassembly consists of a poppet type valve guided by a specially designed control piston with a unique profile. The pressure setting of the poppet valve, being guided by the profile on the control piston, is dependent on the actual displacement of the pump. For lower displacement the pressure setting is high. As displacement is increased, the pressure setting is reduced according to the profile on the control piston. The poppet type valve gets pressure signal either from the modified load sense port (for Pressure Flow Compensated) or the pump outlet pressure (for Pressure Compensated). The power control subassembly regulates this pressure based on the displacement. This regulated pressure is internally fed back to the control piston chamber, which compensates by adjusting the pump displacement appropriately. This results in achieving the desired control of constant input power.

Power Control Adjustment

To adjust the control power setting, power measurement devices are required. For Input power, motor torque and speed need to be measured, typically achieved by use of a clamp style ammeter. For output power, devices for pump pressure and flow measurements are required, such as pressure gages or transducers, and flow meters. The pump comes with factory set power setting. The setting can be changed by loosening the lock nut on top of the control subassembly and turning the adjustment screw with help of a hex key. Rotating adjustment screw clockwise increases the power setting while rotating it anti-clockwise reduces it. After adjustment as required ensure that the locknut is tightened properly.

Performance

Quiet version, optimized for 1000-1800 rpm (E) PVM098

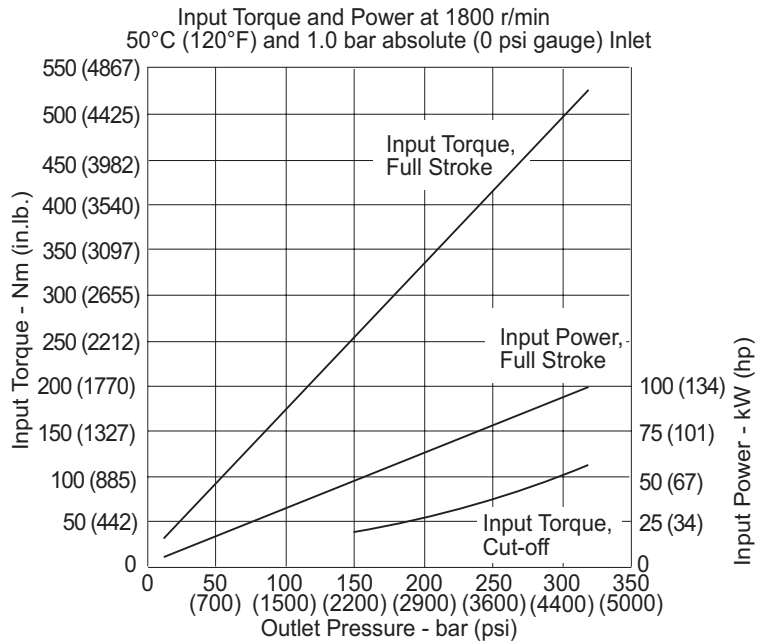
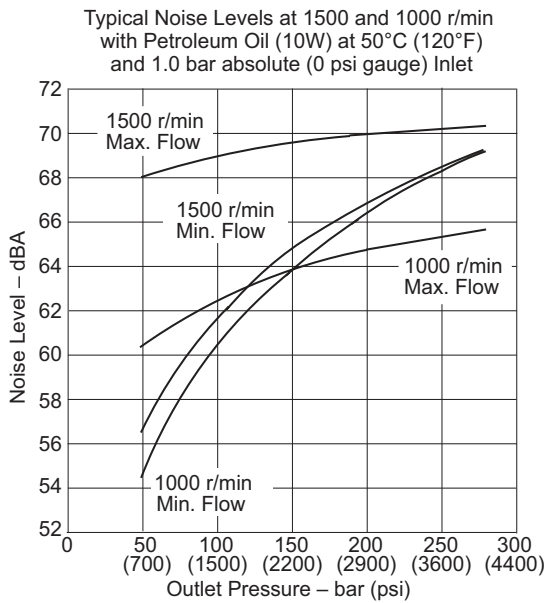
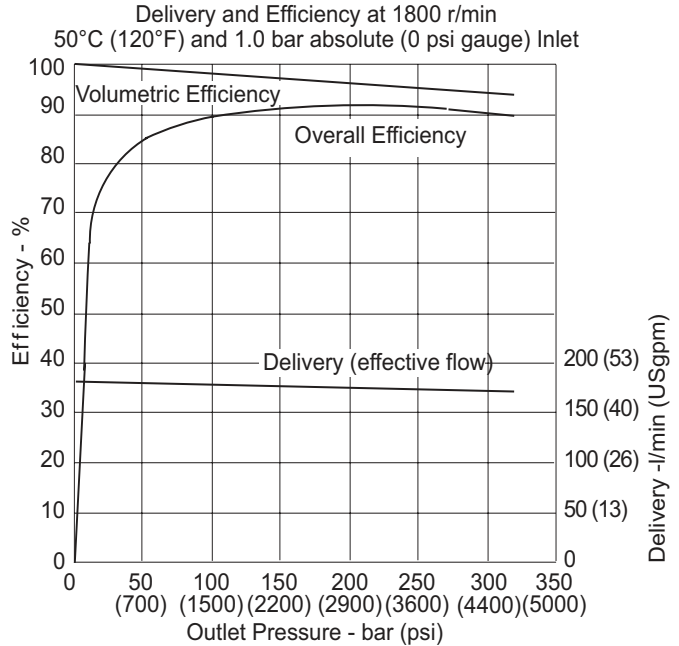
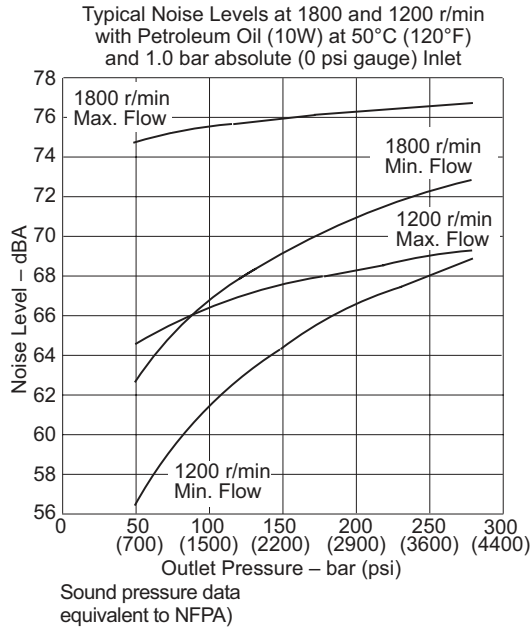

Performance

Quiet version, optimized for 1000-1800 rpm (E) PVM098

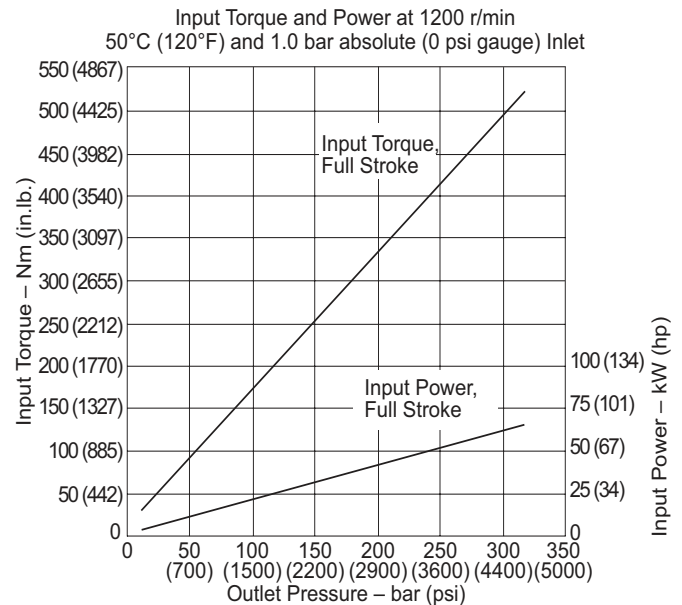
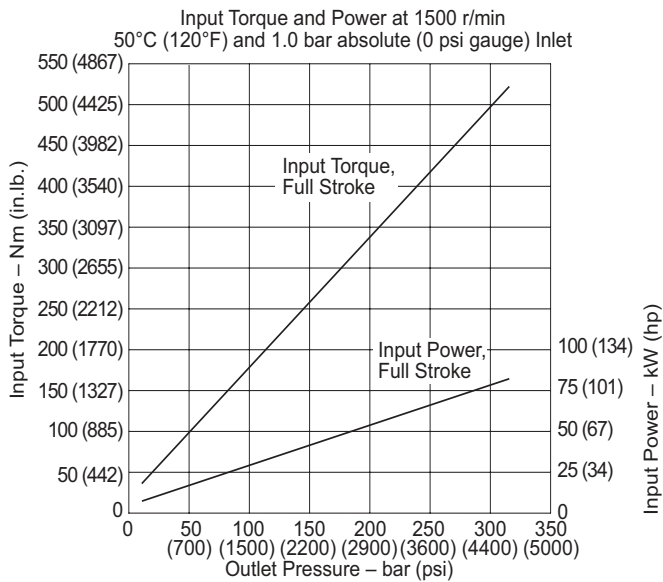
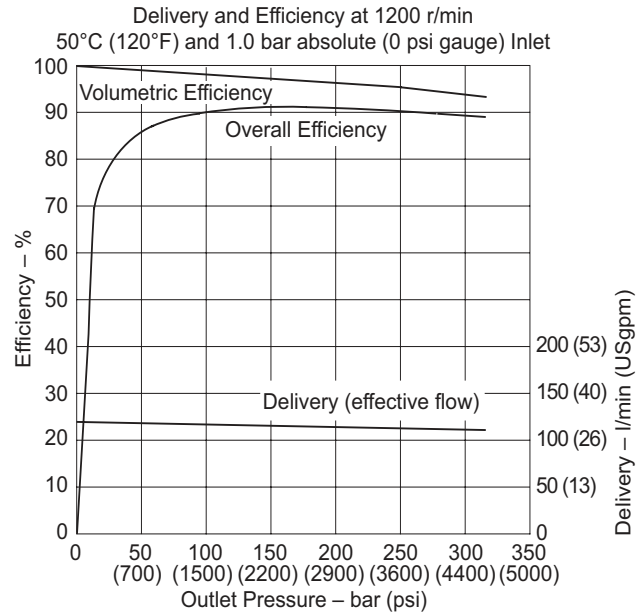
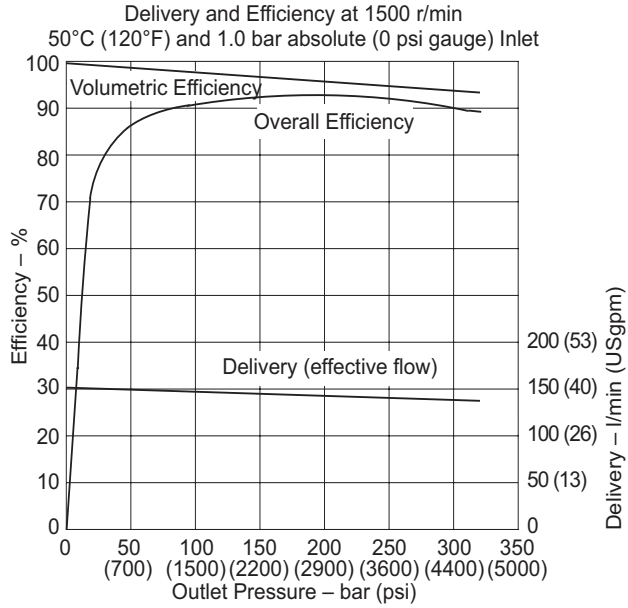

Performance

Quiet version, optimized for 1000-1800 rpm (E) PVM098

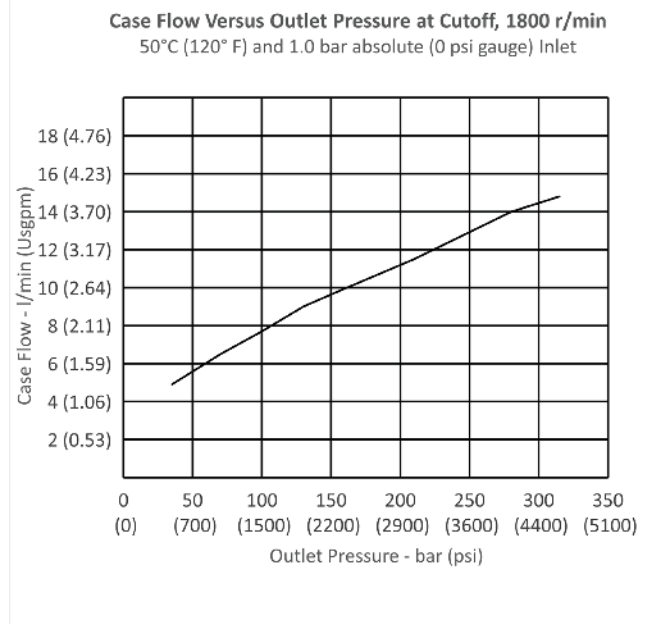
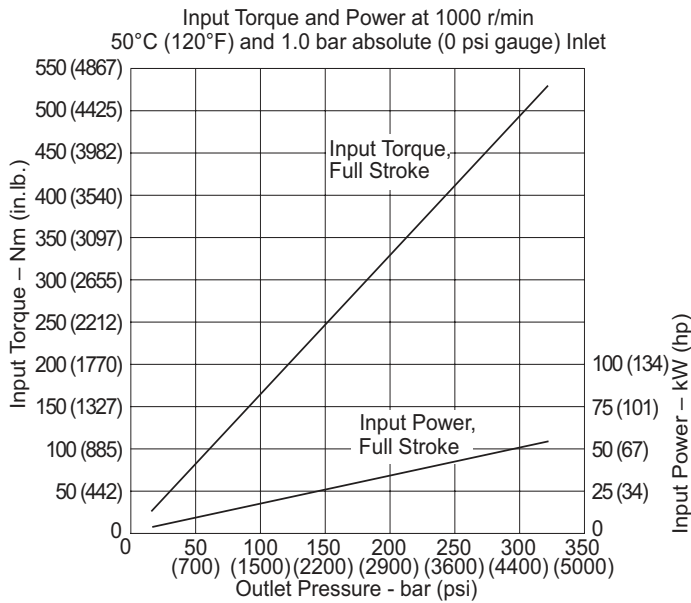
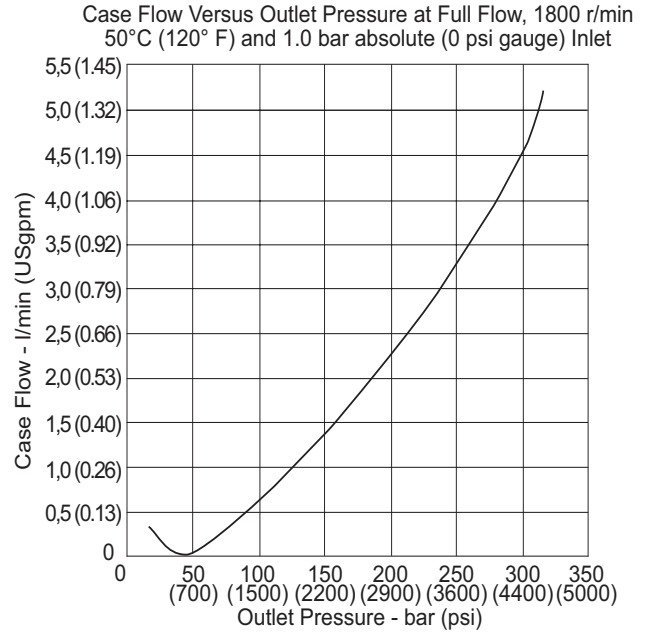
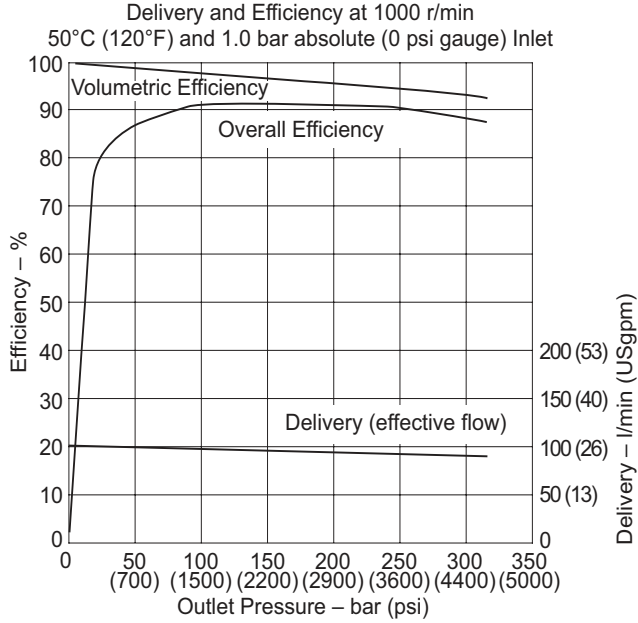

Performance

Higher speed version (M) PVM098

Typical Noise Levels at 2000 and 600 r/min with petroleum oil (10 W) @ 93°C (200°F) and 1.0 bar absolute (0 psi gauge) inlet

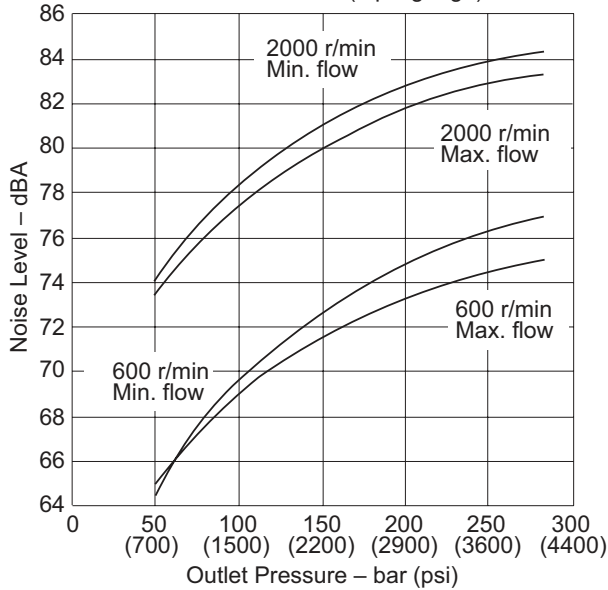

Sound pressure data equivalent to NFP

Delivery and Case Flow Versus Speed @ 93°C (200°F), full flow and 1.0 bar absolute (0 psi) gauge Inlet

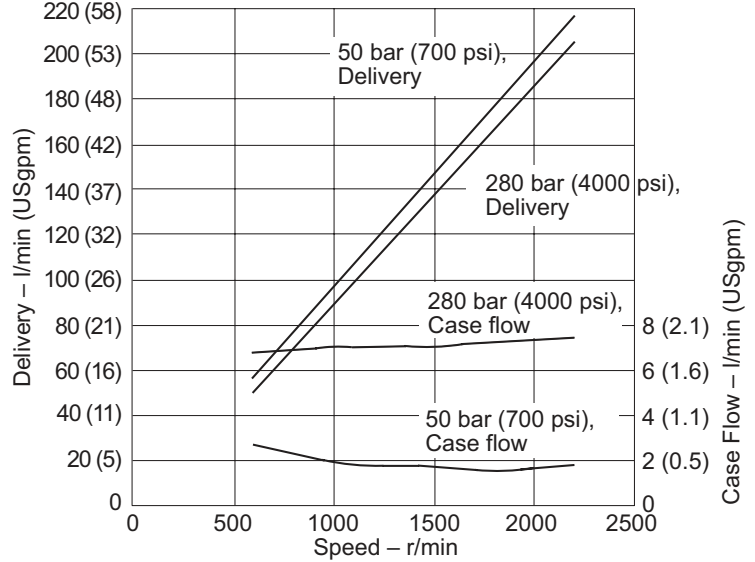

Overall Efficiency Versus Speed @ 93°C (200°F) and 1.0 bar absolute (0 psi gauge) inlet

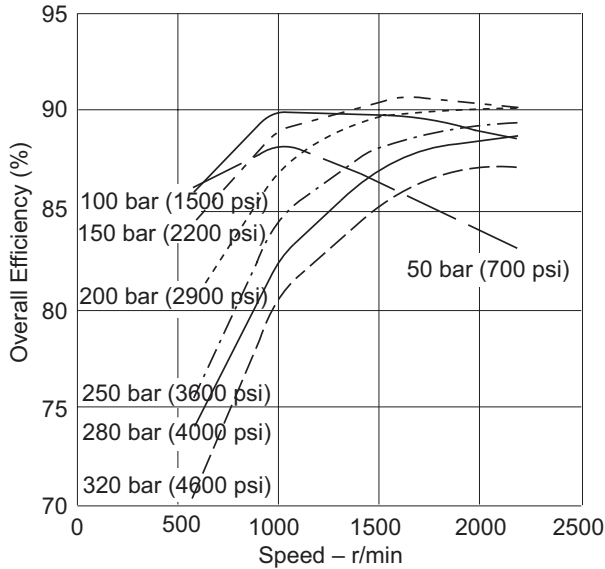

Input Torque Versus Speed @ 93°C (200°F), full flow and 1.0 bar absolute (0 psi) gauge inlet

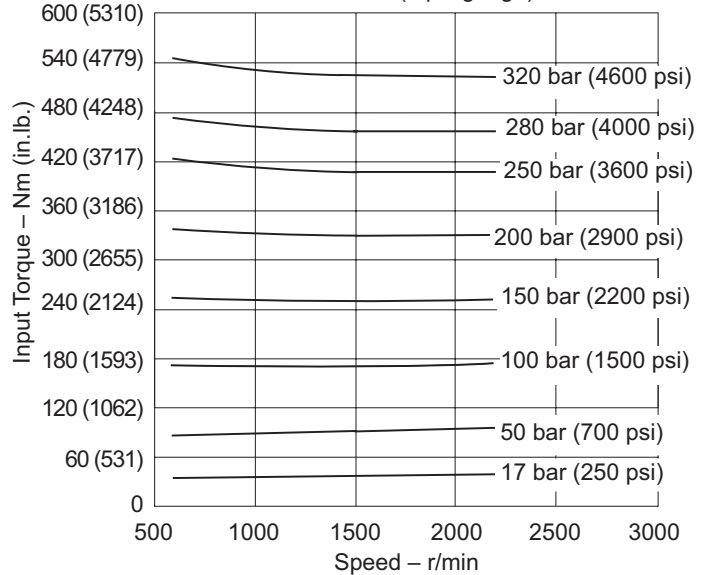

Performance

Higher speed version (M) PVM098

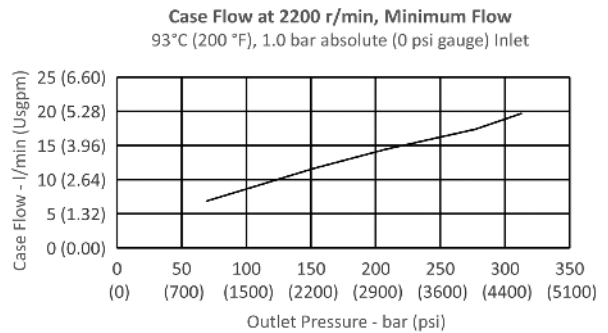
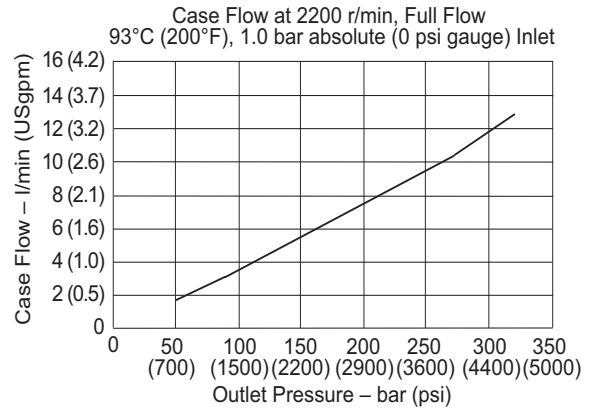
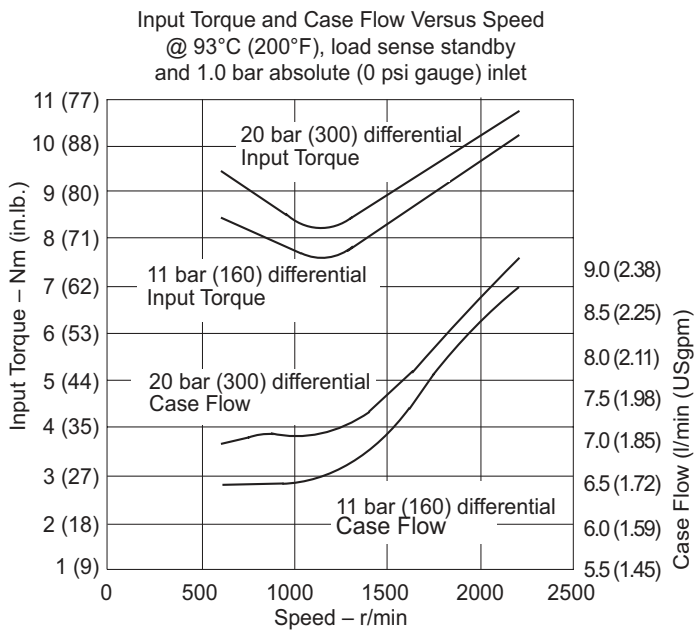
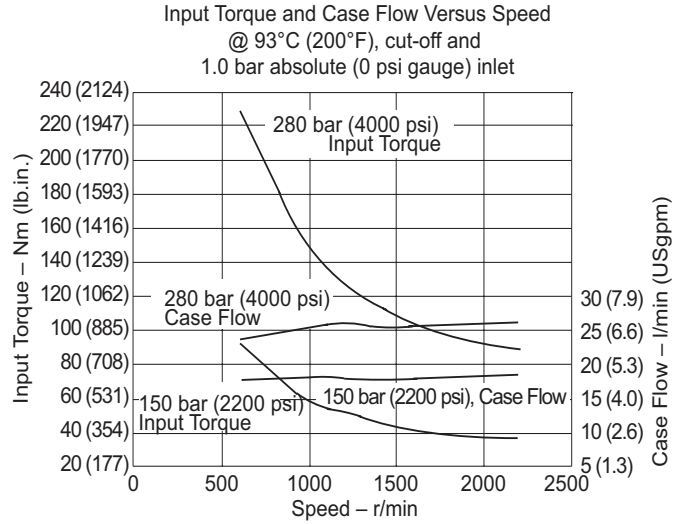
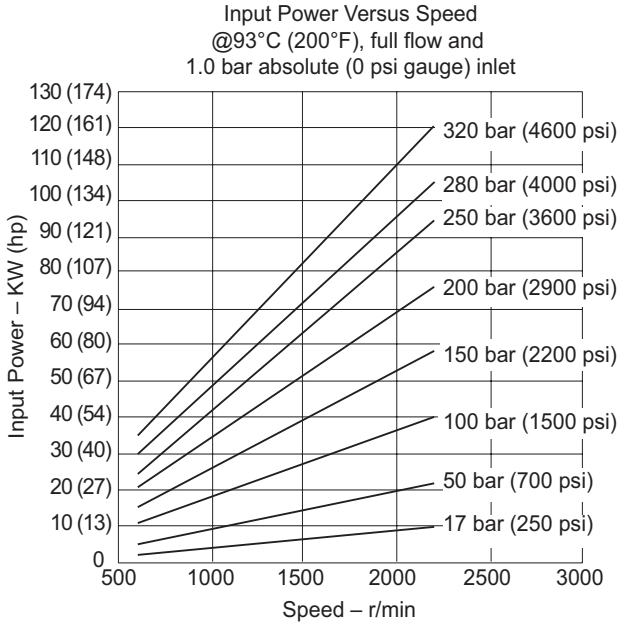

Performance

Quiet version, optimized for 1000-1800 rpm (E) PVM106

Typical Noise Levels at 1800 and 1200 r/min. with Petroleum Oil (10W) at 50°C (120°F) and 1.0 bar absolute (0 psi gauge) Inlet

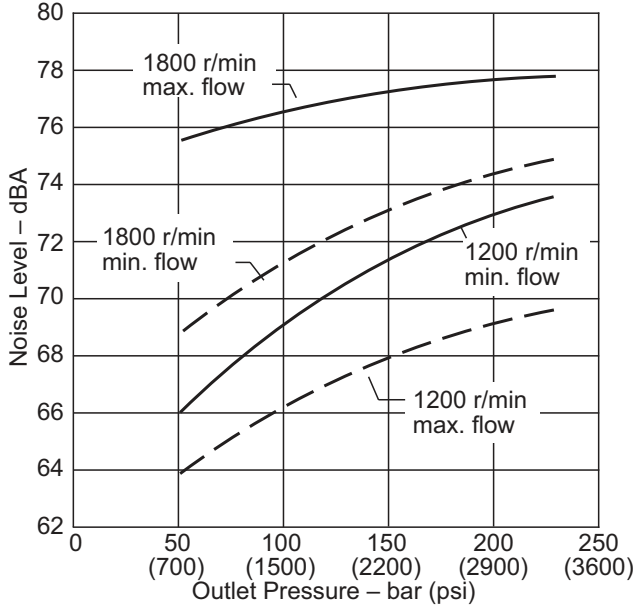

Delivery and Efficiency at 1800 r/min, 50C (120F), and 1.0 bar absolute (0 psi gauge) Inlet

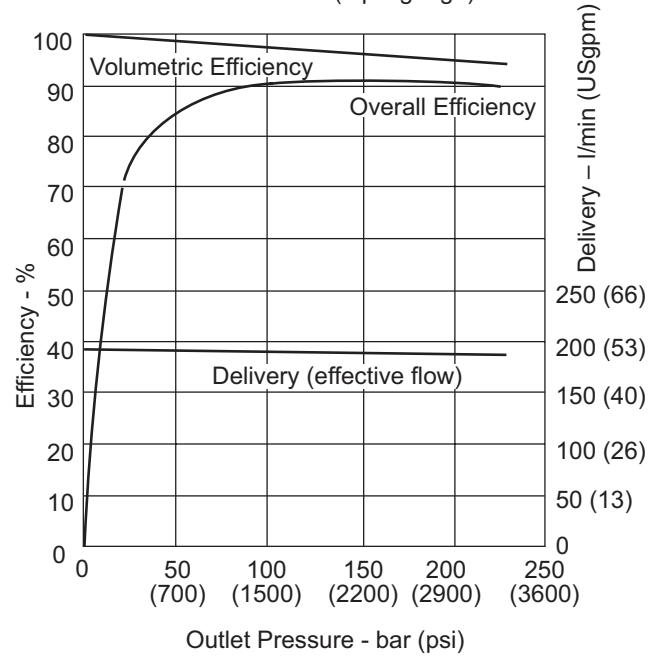

Typical Noise Levels at 1500 and 1000 r/min. with Petroleum Oil (10W) at 50°C (120°F) and 1.0 bar absolute (0 psi gauge) Inlet

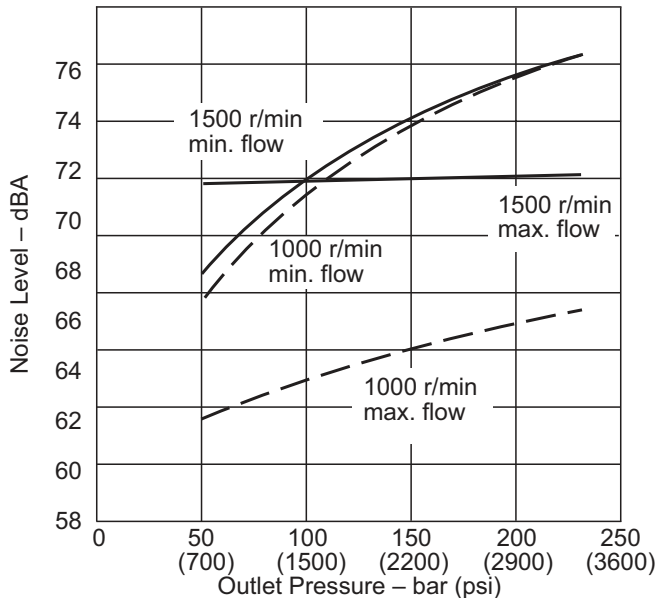

Input Torque and Power at 1800 r/min, 50C (120F), and 1.0 bar absolute (0 psi gauge) Inlet

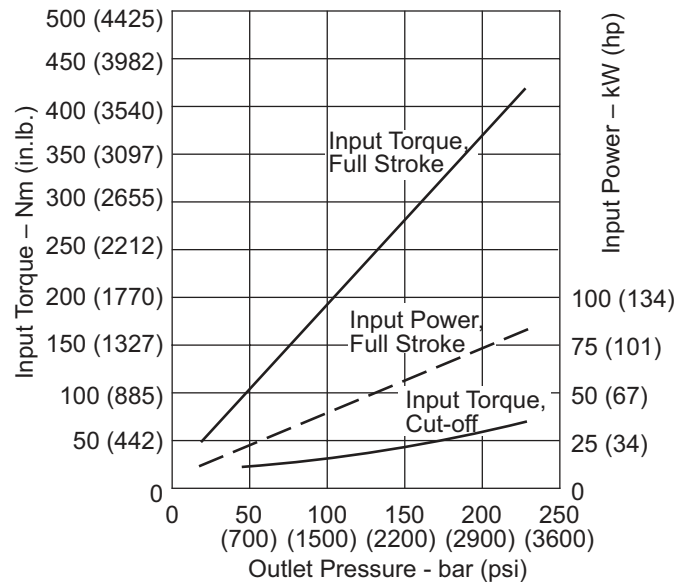

Sound pressure data equivalent to NFPA.

Performance

Quiet version, optimized for 1000-1800 rpm (E) PVM106

Delivery and Efficiency at 1500 r/min, 50C (120F), and 1.0 bar absolute (0 psi gauge) Inlet

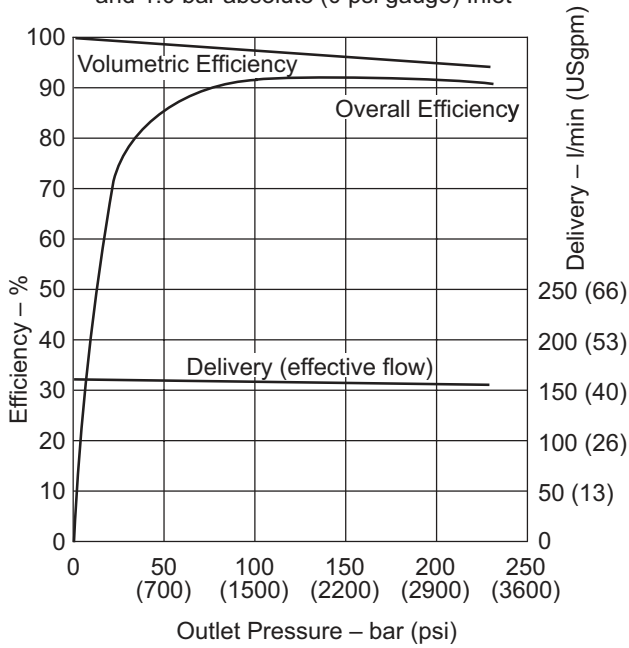

Delivery and Efficiency at 1200 r/min, 50C (120F), and 1.0 bar absolute (0 psi gauge) Inlet

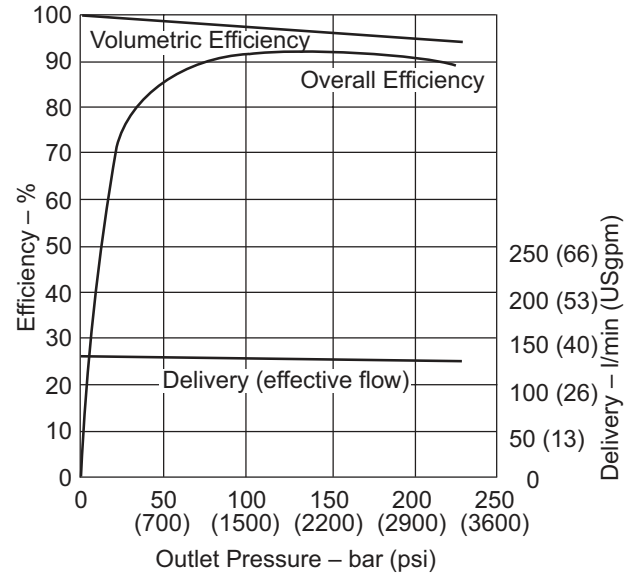

Input Torque and Power at 1500 r/min, 50C (120F), and 1.0 bar absolute (0 psi gauge) Inlet

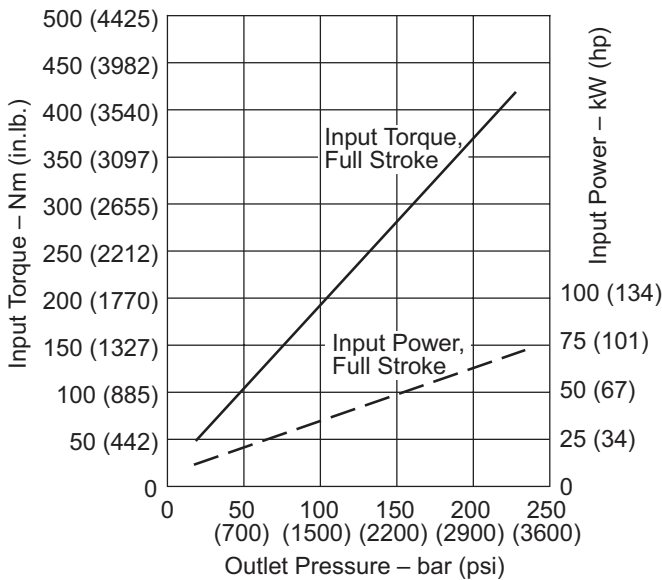

Input Torque and Power at 1200 r/min, 50C (120F), and 1.0 bar absolute (0 psi gauge) Inlet

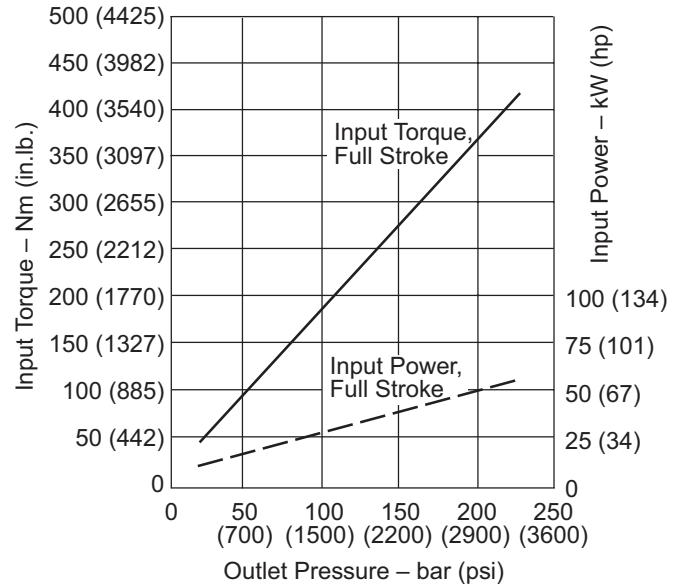

Performance

Quiet version, optimized for 1000-1800 rpm (E) PVM106

Delivery and Efficiency at 1000 r/min, 50C (120F), and 1.0 bar absolute (0 psi gauge) Inlet

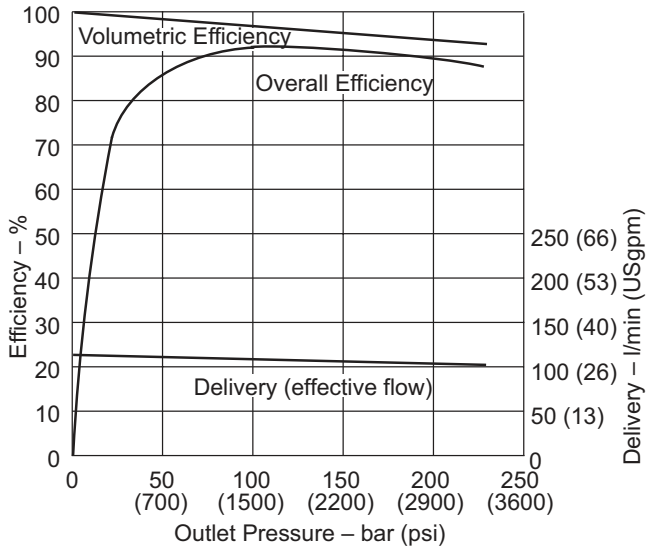

Case Flow versus Outlet Pressure at 1800 r/min, Full Flow, 50°C (120°F), and 1.0 bar absolute (0 psi gauge) Inlet

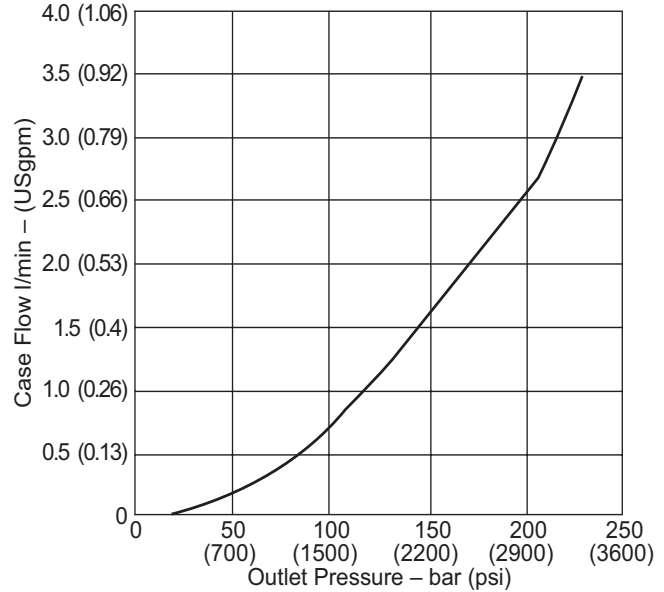

Input Torque and Power at 1000 r/min, 50C (120F), and 1.0 bar absolute (0 psi gauge) Inlet

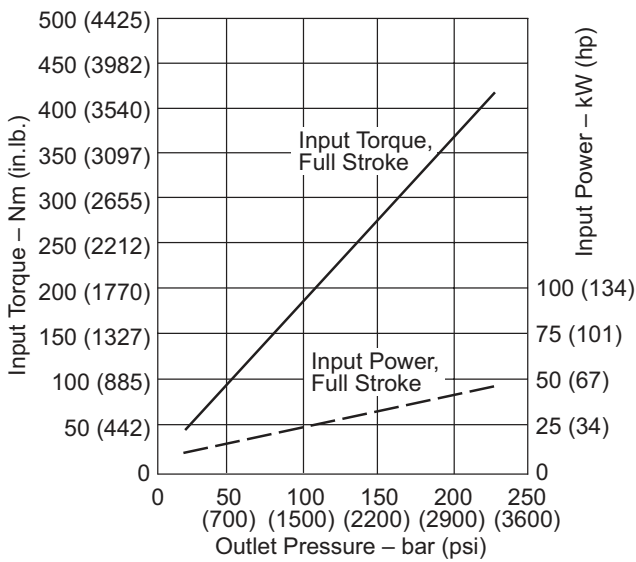

Case Flow versus Outlet Pressure at Cutoff, 1800 r/min, 50°C (120°F), and 1.0 bar absolute (0 psi gauge) Inlet

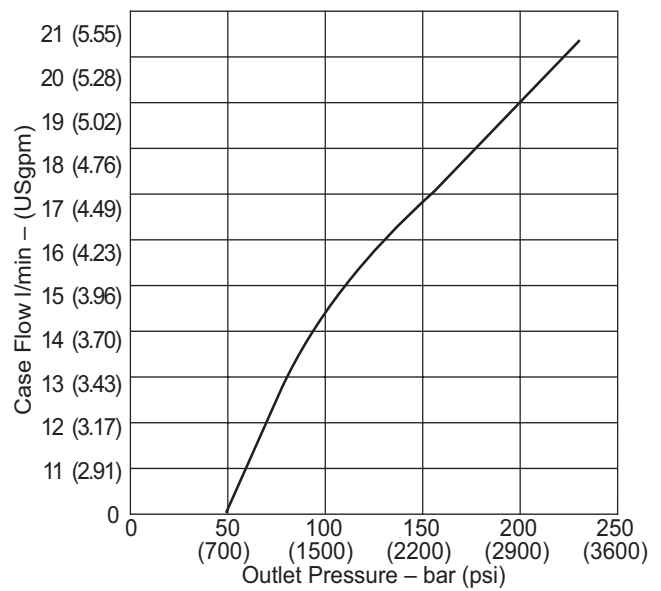

Performance

Higher speed version (M) PVM106

Typical Noise Levels at 2200 & 600 r/min with Petroleum Oil (10W) at 93°C (200°F) and 1.0 bar absolute (0 psi gauge) Inlet

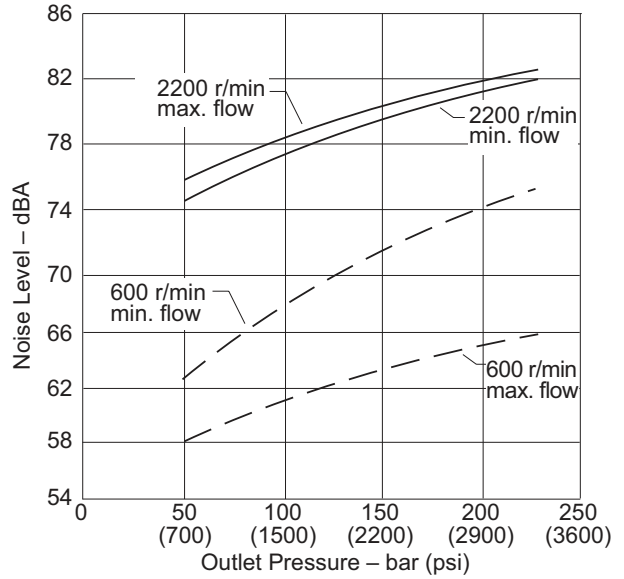

Sound pressure data equivalent to NFPA.

Overall Efficiency versus Speed at 93°C (200°F) and 1.0 bar absolute (0 psi gauge) inlet

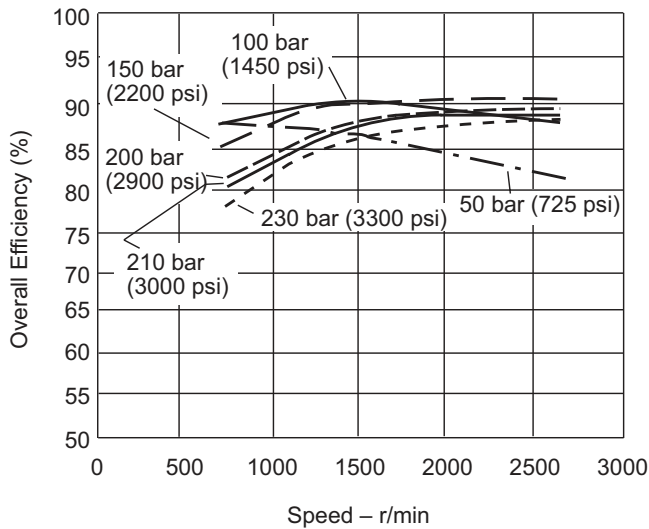

Delivery and Case Flow versus Speed at 93°C (200°F), Full Flow 1.0 bar absolute (0 psi gauge) Inlet

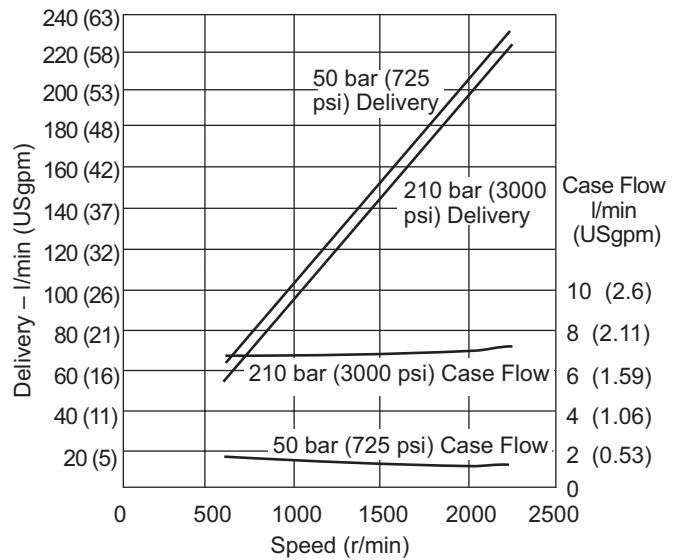

Performance

Higher speed version (M) PVM106

Input Torque versus Speed at 93°C (200°F), Full Flow and 1.0 bar absolute (0 psi gauge) Inlet

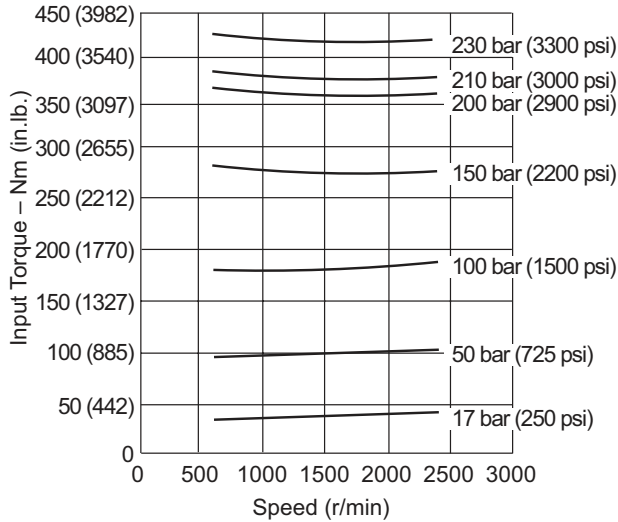

Input Power versus Speed at 93°C (200°F), Full Flow and 1.0 bar absolute (0 psi gauge) Inlet

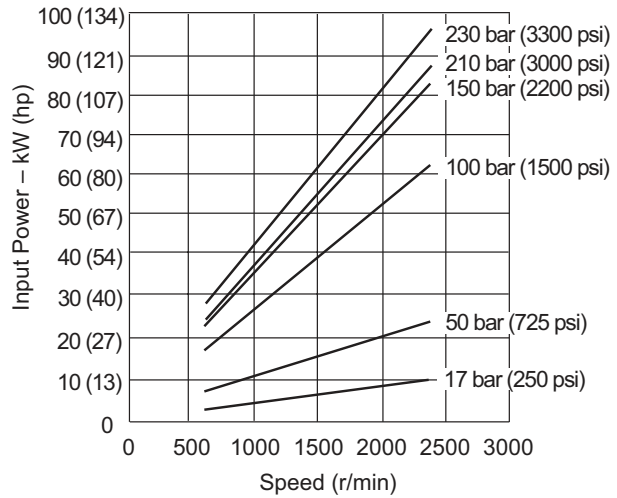

Input Torque and Case Flow versus Speed at 93°C (200°F), Load Sense Standby and 1.0 bar absolute (0 psi gauge) Inlet

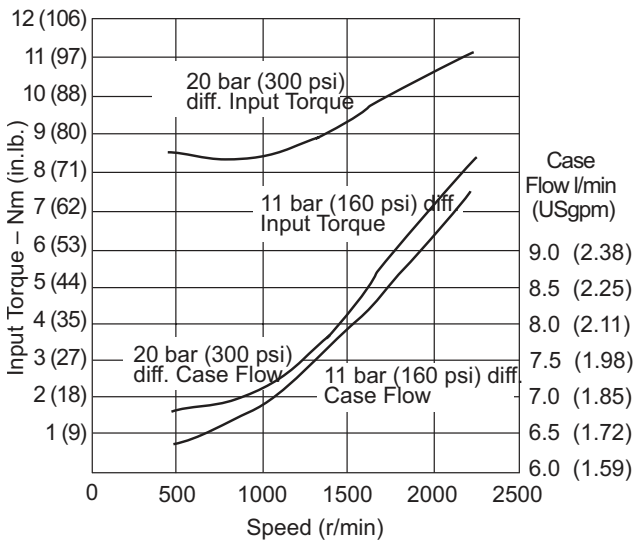

Input Torque and Case Flow versus Speed at 93°C (200°F), Pressure Limit Cut-off and 1.0 bar absolute (0 psi gauge) Inlet

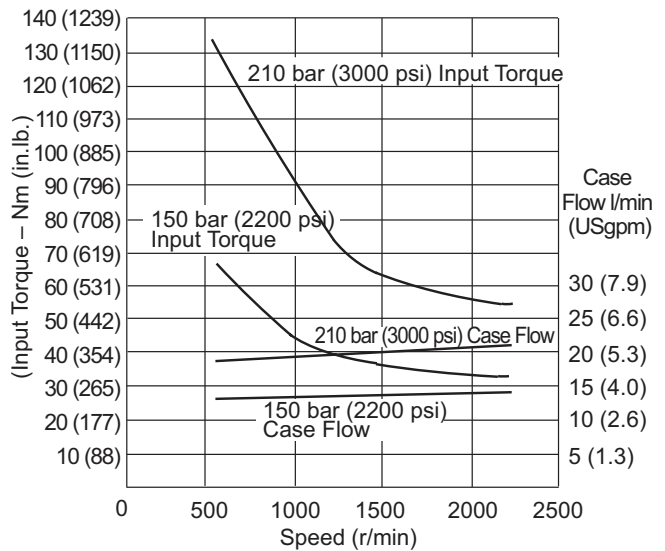

Side-ported Models

Without through-drive capability

PVM098

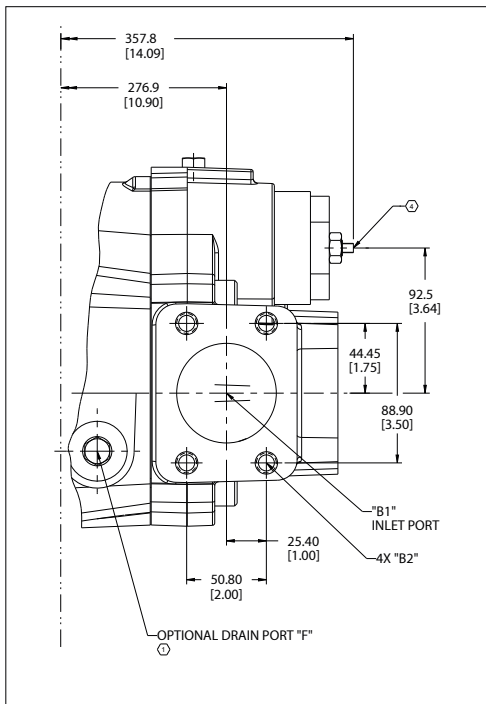
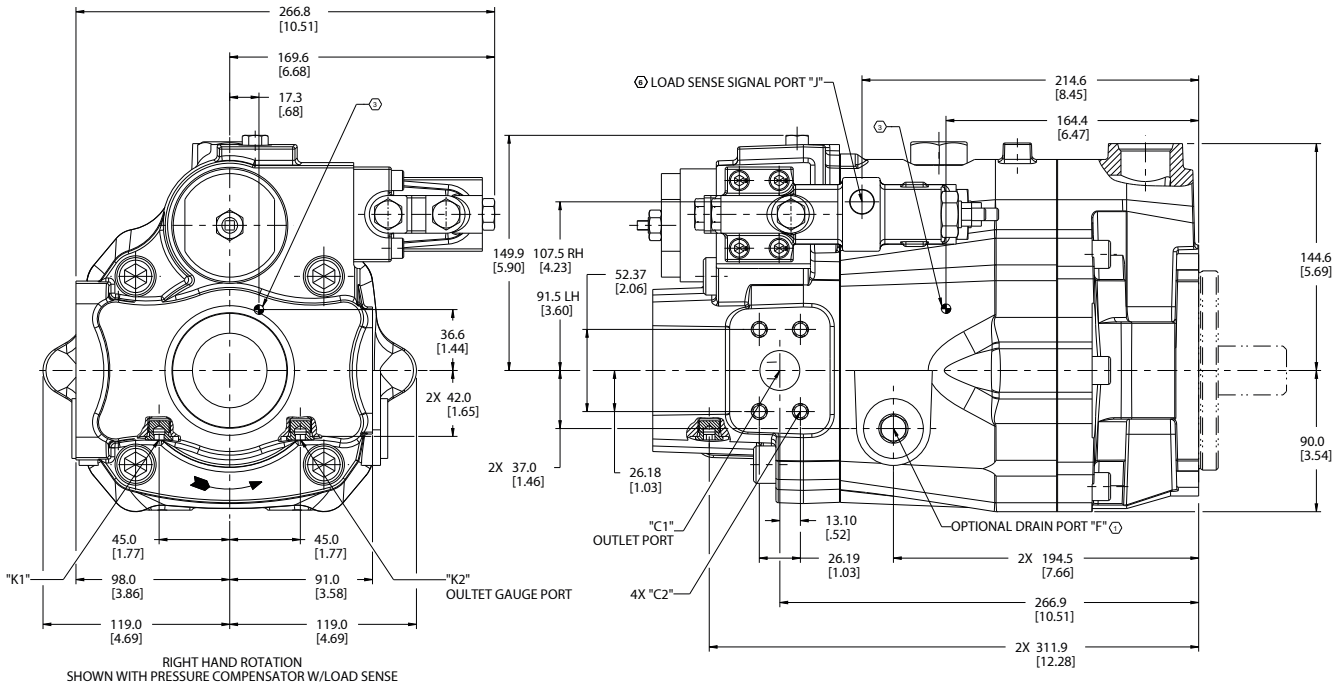

PORT	"B1"	"B2"	"C1"	"C2"	"F"	"J"	"K1"	"K2"
SAE PORT	Ø 2.5 INLET PORT "B1" SAE J518C, 4 BOLT FLANGE PORT STANDARD PRESSURE SERIES	500-13 UNC-2B THREAD ▽ 1.19 MINIMUM	Ø 1.0 OUTLET PORT "C1" SAE J518C, 4 BOLT FLANGE PORT STANDARD PRESSURE SERIES	375-16 UNC-2B THREAD ▽ .88 MINIMUM	SAE J514 O-RING BOSS PORT "F" FOR 1 O.D. TUBE 1.3125-12 UNF-2B THREAD	SAE J514 O-RING BOSS PORT "J" FOR .375 O.D. TUBE .562-18 UNF-2B THD	SAE J514 O-RING BOSS PORT "K1" FOR .375 O.D. TUBE .562-18 UNF-2B THD	SAE J514 O-RING BOSS PORT "K2" FOR .375 O.D. TUBE .562-18 UNF-2B THD

Side-ported Models

With through-drive capability

PVM098

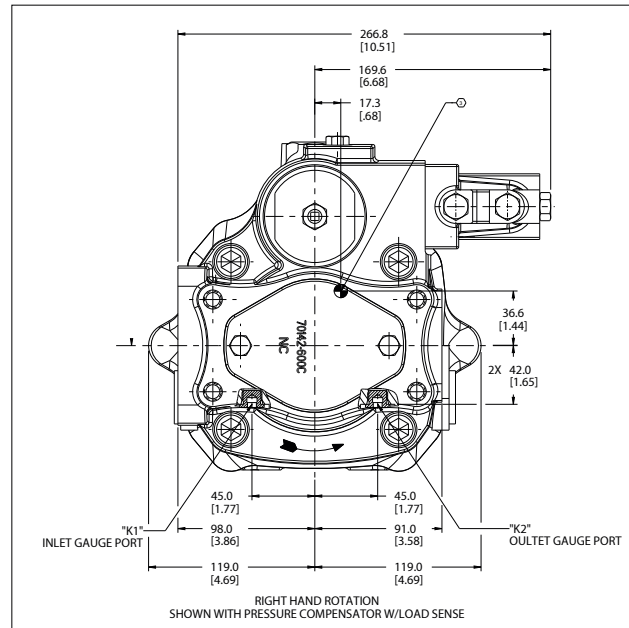
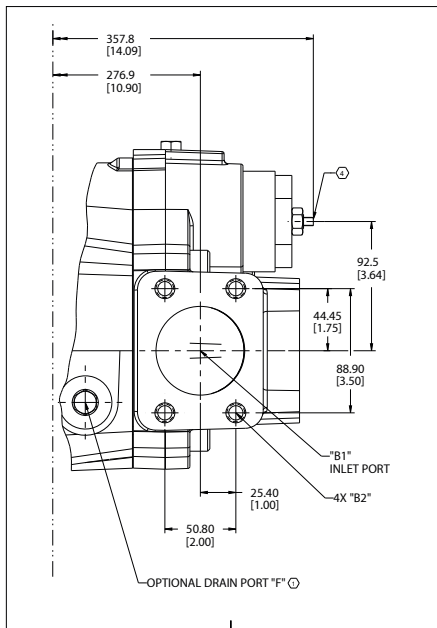
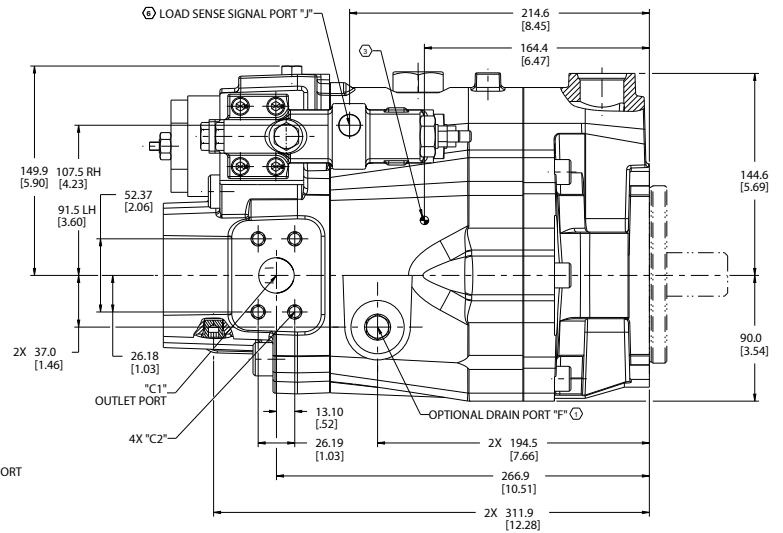
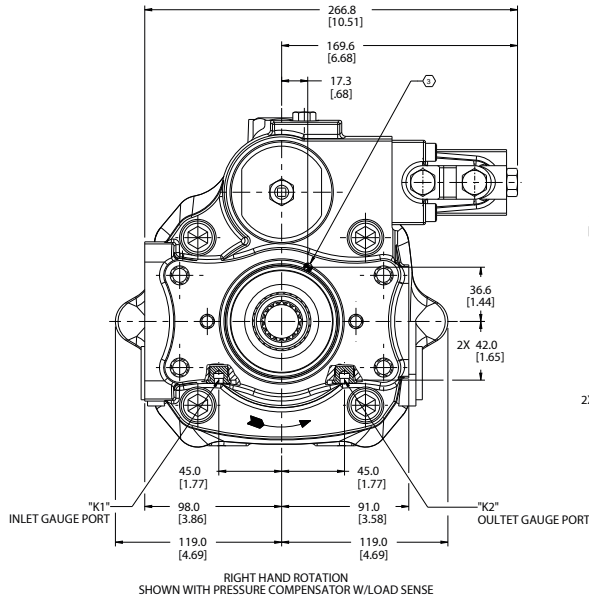

PORT	"B1"	"B2"	"C1"	"C2"	"F"	"J"	"K1"	"K2"
SAE PORT	Ø 2.5 INLET PORT "B1" SAE J518C, 4-BOLT FLANGE PORT STANDARD PRESSURE SERIES	500-13 UNC-2B THREAD ▽ 1.19 MINIMUM	Ø 1.0 OULET PORT "C1" SAE J518C, 4-BOLT FLANGE PORT STANDARD PRESSURE SERIES	375-16 UNC-2B THREAD ▽ .88 MINIMUM	SAE J514 O-RING BOSS PORT "F" FOR 1 O.D. TUBE 1.3125-12 UNF-2B THREAD	SAE J514 O-RING BOSS PORT "J" FOR 375 O.D. TUBE .562-18 UNF-2B THD	SAE J514 O-RING BOSS PORT "K1" FOR 375 O.D. TUBE .562-18 UNF-2B THD	SAE J514 O-RING BOSS PORT "K2" FOR 375 O.D. TUBE .562-18 UNF-2B THD
ISO PORT	NA	NA	NA	NA	NA	NA	NA	NA

Through-drive Models

PVM098

Generic through-drive assembly

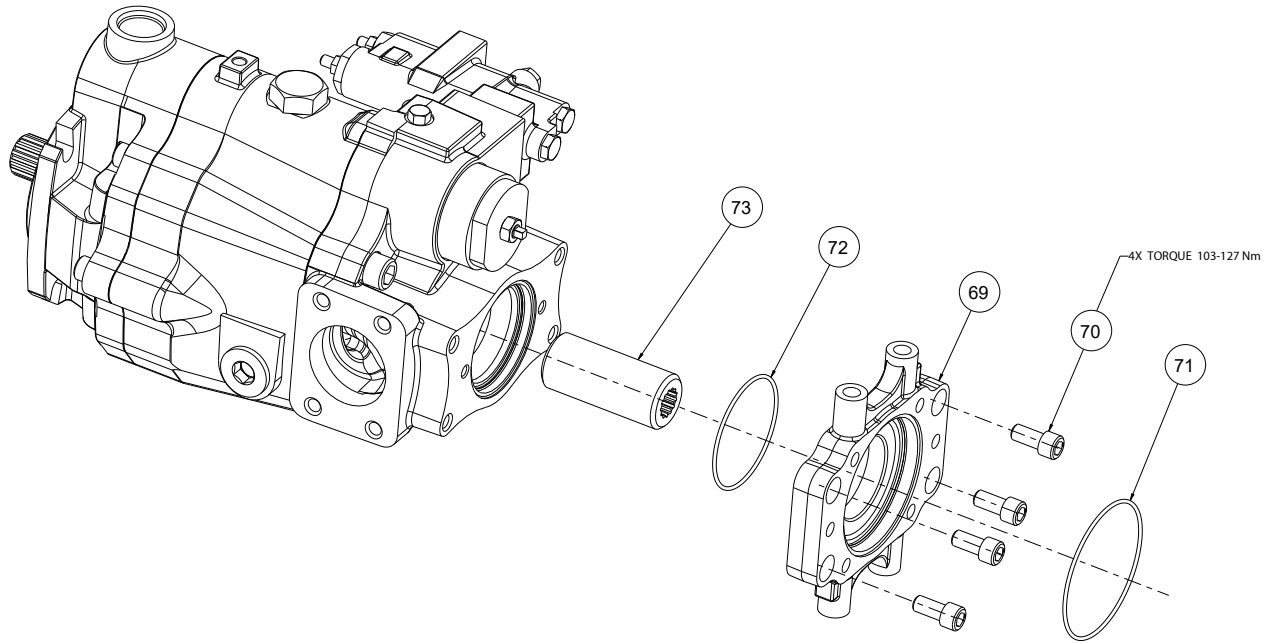

MODEL CODE POSITION 23	Item No. 69 (Adapter) (QTY 1)	Item No.70 (Screw) (QTY 4)	Item No.71 (O-ring) (QTY 1)	Item No.72 (O-ring) (QTY 1)	Item No.73 (Coupler) (QTY 1)
A	○	○	○	●	●
B	○	○	○	●	●
C	●	●	●	●	●
D	●	●	●	●	●
E	●	●	●	●	●
F	●	●	●	●	●

○ = Not required for through-drive

● = Required for through-drive

Model Code Position 23	
Description	
A	SAE "A," 9T, 16/32 DP, 30° pressure angle, involute spline
B	SAE "A," 11T, 16/32 DP, 30° pressure angle, involute spline
C	SAE "B," 13T, 16/32 DP, 30° pressure angle, involute spline
D	SAE "B-B," 15T, 16/32 DP, 30° pressure angle, involute spline
E	SAE "C," 14T, 12/24 DP, 30° pressure angle, involute spline
F	SAE "C-C," 17T, 12/24 DP, 30° pressure angle, involute spline

Thru-drive Models

PVM098

SAE "A" Adaptor Flange

Features are in metric but use inch threads

Dimensions are in millimeters (inches)

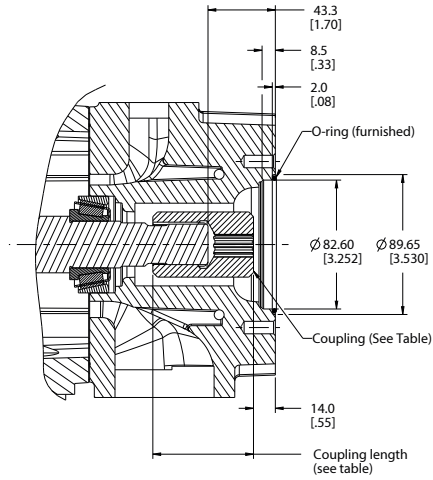

Without adapter plate

Model Code Position 23	Coupling	Length mm (inch)
A	SAE "A," 9T	64.5 (2.54)
B	SAE "A," 11T	65.3 (2.57)

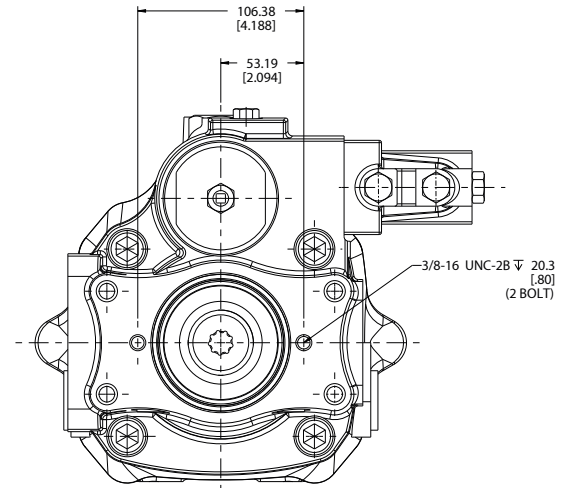
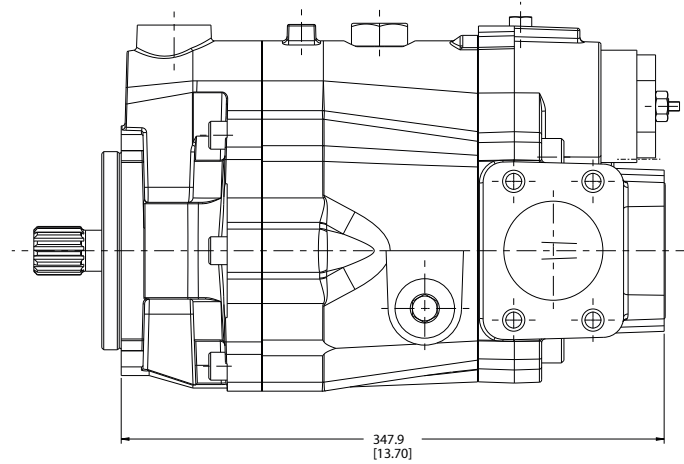

Right hand rotation
Shown with Pressure Compensator with Load Sense

Thru-drive Models

PVM098

SAE "B" Adaptor Flange

Features are in metric but use inch threads

Dimensions are in millimeters (inches)

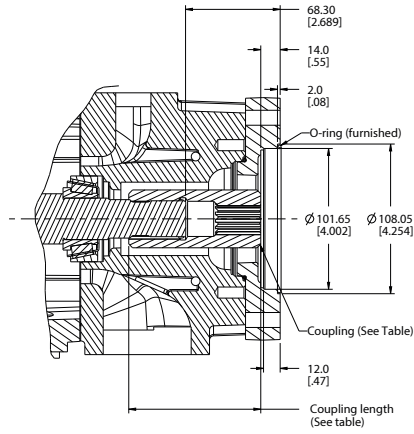

With adapter plate

Model Code Position 23	Coupling	Length mm (inch)
C	SAE "B," 13T	95.3 (3.75)
D	SAE "B-B," 15T	95.3 (3.75)

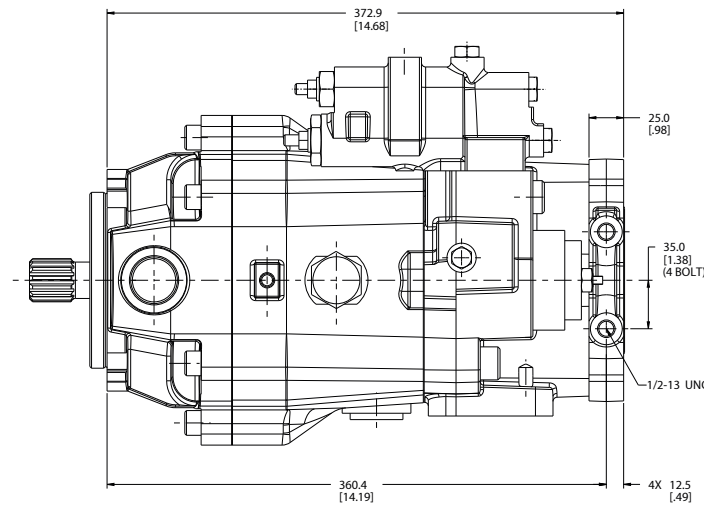

View Rotated 90°

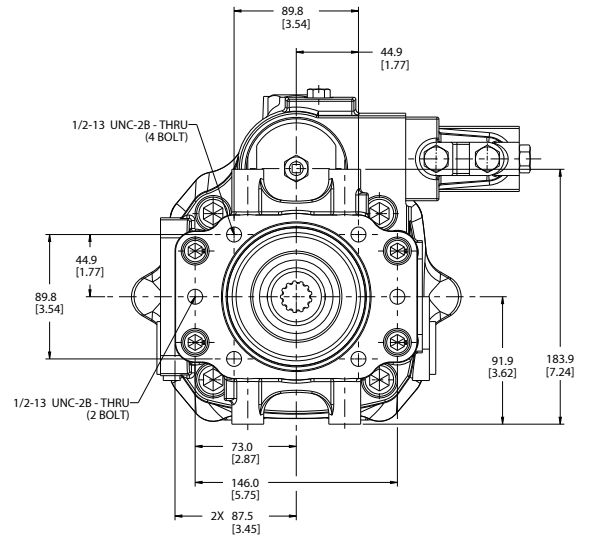

Right hand rotation
Shown with Pressure Compensator with Load Sense

Thru-drive Models

PVM098

SAE "C" Adaptor Flange

Features are in metric but use inch threads

Dimensions are in millimeters (inches)

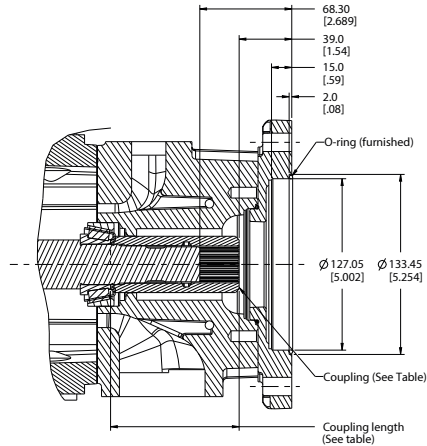

Model Code Position 23	Coupling	Length mm (inch)
E	SAE "C," 14T	95.3 (3.75)
F	SAE "C-C," 17T	91.8 (3.61)

With adapter plate

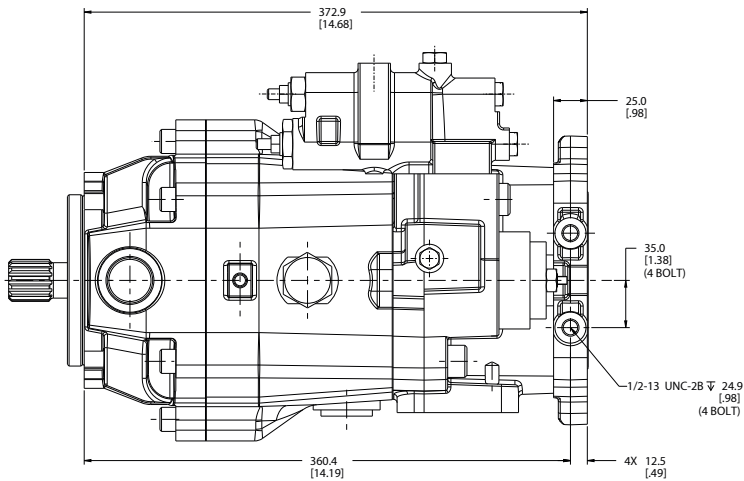

View Rotated 90°

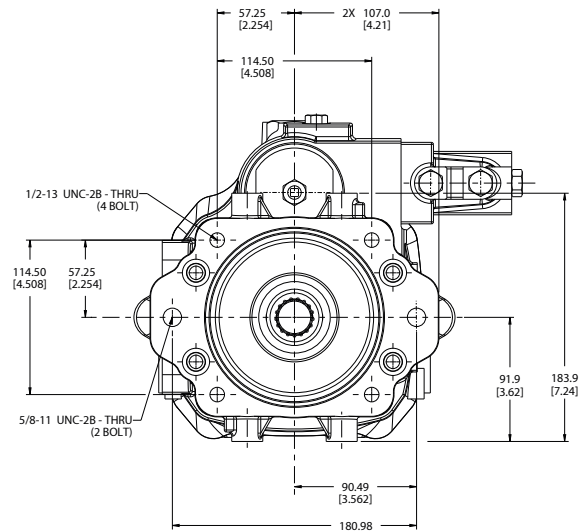

Right hand rotation
Shown with Pressure Compensator with Load Sense
and SAE 2-/4-bolt "C" Adapter Flange

Mounting Flange Options

G – SAE J744-127-4 C 4-BOLT

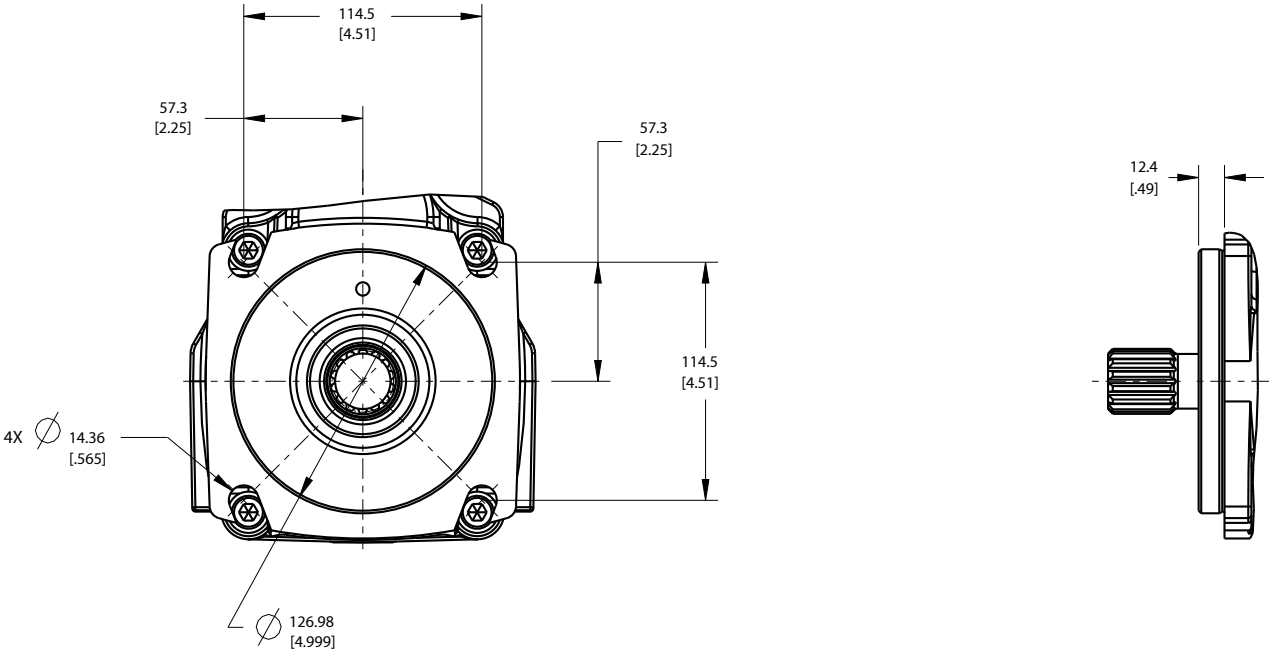

Shaft Options

09 - SAE J744-32-1 SAE C STRAIGHT KEYED

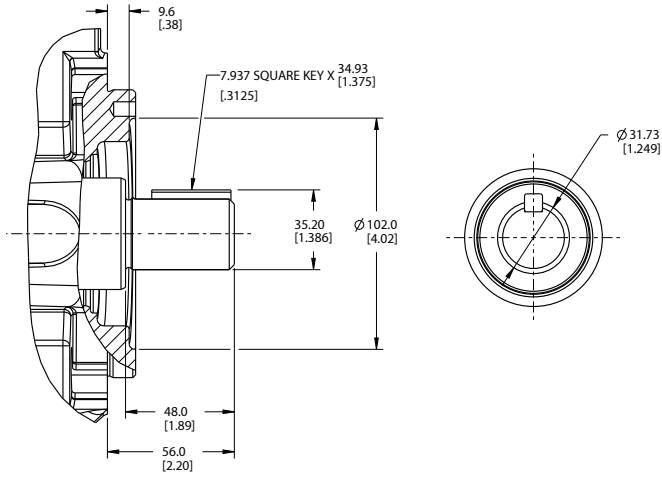

10 - SAE J744-38-1 SAE C-C STRAIGHT KEYED

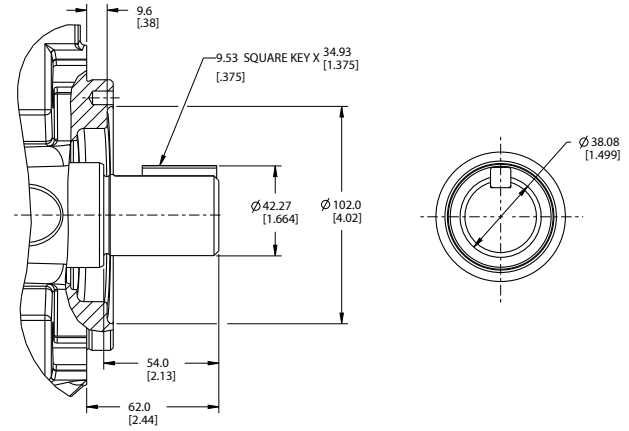

11 - SAE J744-32-4 SAE C 14T SPLINE

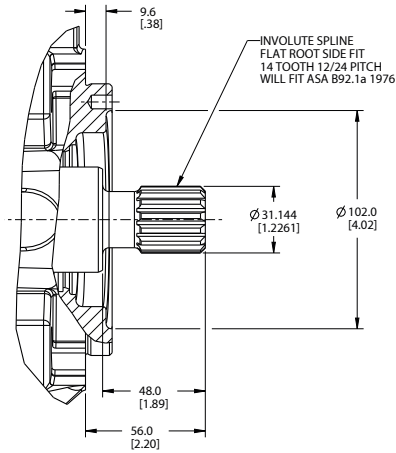

12 - SAE J744-38-4 SAE C-C 17T SPLINE

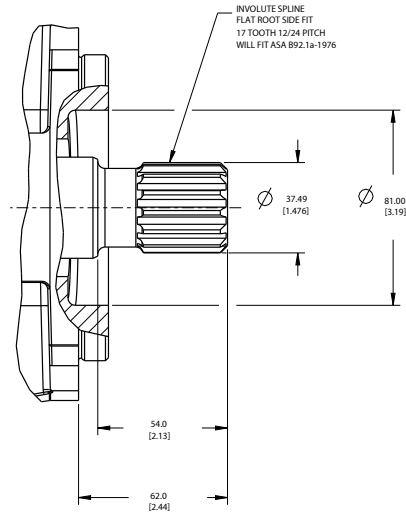

24 - 24 - 31.8 [1.25] DIA TAPERED KEYED SHAFT .750-16 UNF-2A EXTERNAL THREAD KEY INCLUDED

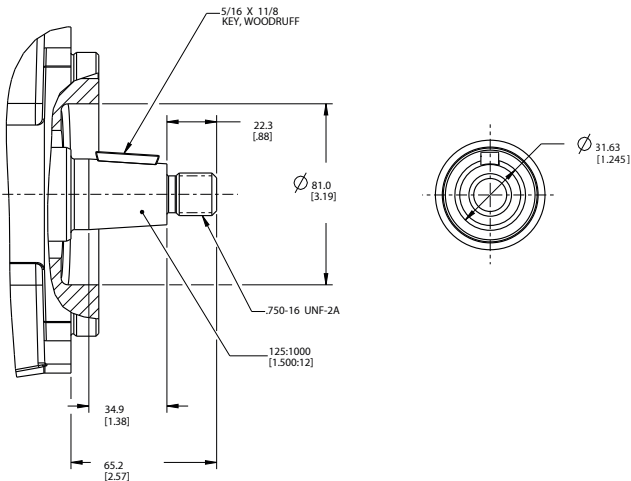

Input Shaft Selection Data

SAE Splined Shafts

Model Series	Shaft Designation	Shaft Code	Max. Input Torque† Nm (lb. in.)	Max. Thru-drive Output Torque‡ Nm (lb. in.)
PVM098/106	SAE J744-32-4 (SAE "C," 14T)	11	640 (5660)	640 (5660)
	SAE J744-38-4 (SAE "C-C," 17T)	12	1215 (10,750)	640 (5660)

SAE Keyed Shafts

Model Series	Shaft Designation	Shaft Code	Max. Input Torque† Nm (lb. in.)	Max. Thru-drive Output Torque‡ Nm (lb. in.)
PVM098/106	SAE J744-32-1 (SAE "C")	09	450 (3980)	450 (3980)*
	SAE J744-38-1 (SAE "C-C")	10	765 (6770)	640 (5660)

†Maximum total torque of the thru-drive pump and the thru-driven pump(s).

‡Maximum torque that can be applied to the thru-driven pump(s).

*This value is limited by the maximum input torque.

Port Options

Inlet and Outlet Ports

Model Series	Inlet/Outlet Port Option	Port Code	Inlet Port "B"	Outlet Port "C"
PVM098/106	Inch Flange	2	SAE J518 Code 61, standard pressure. 2.50 inch diameter, .500-13 x 1.19 bolt holes	SAE J518 Code 62, high pressure. 1.25 inch diameter, .500 -13 x 1.00 bolt holes

Drain, Load Sensing, and Gauge Ports

Model Series	Inlet/Outlet Port Option	Port Code	Drain Port "F"	Load Sensing Port "J"	Gauge Port "K"
PVM098/106	Inch Flange	2	SAE J514 O-ring, 1" O.D. tube. 1.3125-12UN-2B thread	SAE J514 O-ring, .375" O.D. tube. .562-18 UNF 2B thread	SAE J514 O-ring, .375" O.D. tube. .5625-18 UNF 2B thread

Operating Requirements

Inlet Pressure, Case Pressure, and Operating Temperature Requirements

Inlet Pressure			Case Pressure			Operating Temperature	
Rated Absolute bar (psi)	Minimum bar, absolute (in. Hg)	Maximum Gauge bar (psi)	Maximum Continuous bar (psi)	Maximum Intermittent bar (psi)	Peak bar (psi)	Rated °C (°F)	Maximum Intermittent °C (°F)
1,0 (14.5)	0,85 (5)	3,5 (50)	0,5 (7)	2 (30)	3,5 (50)	82 (180)	104 (220)

Hydraulic Fluids

Fluid	Recommended Operating Viscosity Range cSt (SUS)	Maximum Viscosity at Startup cSt (SUS)	Minimum Viscosity @ Max. Intermittent Temperature of 104°C (220°F) cSt (SUS)
Use antiwear hydraulic oil, or automotive type crankcase oil (designations SC, SD, SE, or SF) per SAE J183 FEB80	16 to 40 (83 to 187)	1000 (4550)	10 (90)

For more information, see Danfoss publication 579. For operation on other alternative or environmentally friendly fluids, please contact your Danfoss Representative.

Bearing life at 50° C (120° F), SAE 10W oil, 1 bar abs (0 psig) inlet pressure

Model Series	Pressure _{rated} bar (psi)	Speed _{rated} rpm	Flow _{rated} lpm (gpm)	Bearing life _{rated} L10 hours
098	315 (4568)	1800	170 (45)	11000

Bearing life can be modified for flow, speed and pressure using the formula:

$$L_{\text{adjusted}} = \text{life}_{\text{rated}} \times \left(\frac{\text{Pressure}_{\text{rated}}}{\text{Pressure}_{\text{adjusted}}} \right)^{3.33} \times \left(\frac{\text{Speed}_{\text{rated}}}{\text{Speed}_{\text{adjusted}}} \right) \times \left(\frac{\text{Flow}_{\text{rated}}}{\text{Flow}_{\text{adjusted}}} \right)^{3.33}$$

Example: PVM131 operating at 1200 rpm, at 230 bar, and 200 lpm

From the chart, find that the rated life is 14000 L10 hours, the rated pressure is 315 bar, the rated flow is 215 lpm and the rated speed is 1800 rpm. Using the formula provided, the new bearing life expectation is calculated as follows:

$$L_{\text{adjusted}} = 14000 \times \left(\frac{315}{230} \right)^{3.33} \times \left(\frac{1800}{1200} \right) \times \left(\frac{215}{200} \right)^{3.33}$$

$$L_{\text{adjusted}} = 14000 \times 2.85 \times 1.5 \times 1.27$$

$$L_{\text{adjusted}} = 76010 \text{ L10 hours}$$

Further modification to bearing life are possible, including de-rating due to special fluids. Generally, standard water-glycol fluids reduce rated bearing life to 20% And case flushing is required. Please contact Danfoss engineering for assistance.

Fluid Cleanliness

The M Series pumps are rated in anti-wear petroleum fluids with a contamination level of 20/18/13 (Danfoss) or ISO 18/13. Operation in fluids with levels more contaminated than this is not recommended. Fluids other than petroleum, severe service cycles, or temperature extremes are cause for adjustment of these codes. Please contact your Danfoss Representative for specific duty cycle recommendation.

Vickers by Danfoss M Series pumps, as with any variable displacement piston pumps, will operate with apparent satisfaction in fluids up to the rating specified here. Experience has shown, however, that pump and hydraulic system life is not optimized with high fluid contamination levels (high ISO cleanliness codes).

Proper fluid condition is essential for long and satisfactory life of hydraulic components and systems. Hydraulic fluid must have the correct balance

of cleanliness, materials, and additives for protection against wear of components, elevated viscosity and inclusion of air.

Essential information on the correct methods for treating hydraulic fluid is included in Danfoss publication 561 – “Danfoss Guide to Systemic Contamination Control” – Available from your local Danfoss distributor. In this publication, filtration and cleanliness levels for extending the life of axial piston pumps and other system components are listed. Included is an excellent discussion of the selection of products needed to control fluid condition.

Moment of Inertia (single pump rotating group)

Model	Moment of Inertia	
	N-m (sec ²)	lbf-in (sec ²)
PVM098	0.0132	0.1165
PVM106	0.0123	0.1086

Alternate fluids guide

Specifications and Performance

Fluid Type/ Model Series	Petroleum Base	Petroleum Base	Motor Oil	Universal	Automatic	MI Spec Fluids	Environmentally Acceptable Fluids		Fire Resistant Fluids				Specialty Fluids	Food Grade Fluid	
	ZDDP AW (HM)	Zinc Free AW (HM)		Tractor UTTO	Transmission Fluid ATF		Vegetable Base HETG	Synthetic Base HEES	Phosphate ester HFDR	Synthetic Base HFDU	Polyether polyol - HFDU	Water Glycol - HFC	Water Containing Invert Emulsion - HFB	Cutting Fluids	H1 - approved
1 Model series Quiet version 'E' @ 1800 RPM Unless Noted															
PVM 98	4060 PSI	NR	3625 PSI **	3625 PSI **	3625 PSI **	NR	3625 PSI **	3625 PSI 1800 RPM	3300 PSI **	NR	2500 PSI **	2250 PSI **	NR	3625 PSI **	
PVM 106	3335 PSI	NR	3250 PSI **	3250 PSI **	3250 PSI **	NR	3250 PSI **	3250 PSI 1800 RPM	3000 PSI **	NR	2250 PSI **	2000 PSI **	NR	3250 PSI **	
2 Model Series Higher Speed Version (M)															
PVM 98	4060 PSI 2200 RPM	NR	3625 PSI ** 2200 RPM	3625 PSI ** 2200 RPM	3625 PSI ** 2200 RPM	NR	3625 PSI ** 2200 RPM	3625 PSI 1800 RPM	3300 PSI ** 1800 RPM	NR	2500 PSI ** 1800 RPM	2250 PSI ** 1800 RPM	NR	NR	
PVM 106	3335 PSI 2200 RPM	NR	3250 PSI ** 2200 RPM	3250 PSI ** 2200 RPM	3250 PSI ** 2200 RPM	NR	3250 PSI ** 2200 RPM	3250 PSI 1800 RPM	3000 PSI ** 1800 RPM	NR (PSI) 1800 RPM	2250 PSI ** 1800 RPM	2000 PSI ** 1800 RPM	NR	NR	

Installation and Start-up

⚠ Warning: Care should be taken that mechanical and hydraulic resonances are avoided in the application of the pump. Such resonances can seriously compromise the life and/or safe operation of the pump.

Drive Data

Mounting attitude can be either horizontal or vertical, using the appropriate case drain ports to ensure that the case remains full of fluid at all times. Consult your local Danfoss Representative if a different arrangement is required.

In those cases where geometric tolerances of mounting are critical, or where specific tolerance ranges are required and not specified, consult Danfoss Engineering for specific limits.

Direction of shaft rotation, viewed from the prime mover end, must be as indicated in the model designation on the pump – either right hand (clockwise) or left hand (counterclockwise).

Direct coaxial drive through a flexible coupling is recommended. If drives imposing radial shaft loads are considered, please consult your Danfoss Representative.

Start-up Procedure

Make sure the reservoir and circuit are clean and free of dirt/debris prior to filling with hydraulic fluid.

Fill the reservoir with filtered oil and fill to a level sufficient enough to prevent vortexing at the suction connection to pump inlet. It is good practice to clean the system by flushing and filtering, using an external slave pump.

Caution: Before the pump is started, fill the case through the uppermost drain port with hydraulic fluid of the type to be used. The case drain line must be connected directly to the reservoir and must terminate below the oil level.

Once the pump is started, it should prime within a few seconds. If the pump does not prime, check to make sure that there are no restrictions between the reservoir and the inlet to the pump, that the pump is being rotated in the proper direction, and that there are no air leaks in the inlet line and connections. Also check to make sure that trapped air can escape at the pump outlet.

After the pump is primed, tighten the loose outlet connections, then operate for five to ten minutes (unloaded) to remove all trapped air from the circuit.

If the reservoir has a sight gage, make sure the fluid is clear – not milky.

ENGINEERING
TOMORROW

Danfoss

VICKERS
by Danfoss

Danfoss Power Solutions, Nordborgvej 81, 6430 Nordborg, Denmark, Tel. +45 74 88 22 22, Fax +45 74 65 25 80

danfoss.com/VickersIndustrial, E-mail: info@danfoss.com

Support E-mail: industrialpumpsmotorsupport@danfoss.com

Danfoss can accept no responsibility for possible errors in catalogues, brochures and other printed material. Danfoss reserves the right to alter its products without notice. This also applies to products already on order provided that such alterations can be made without subsequential changes being necessary in specifications already agreed. All trademarks in this material are property of the respective companies. Danfoss and the Danfoss logotype are trademarks of Danfoss A/S. All rights reserved.

© 2024 Danfoss
All Rights Reserved
Printed in USA
Document No. V-PUPI-TM007-E3
DAM No: BC488979909885en-000102
June 2024