

Installation Guide

Controller unit and expansion module



148R9637

148R9637

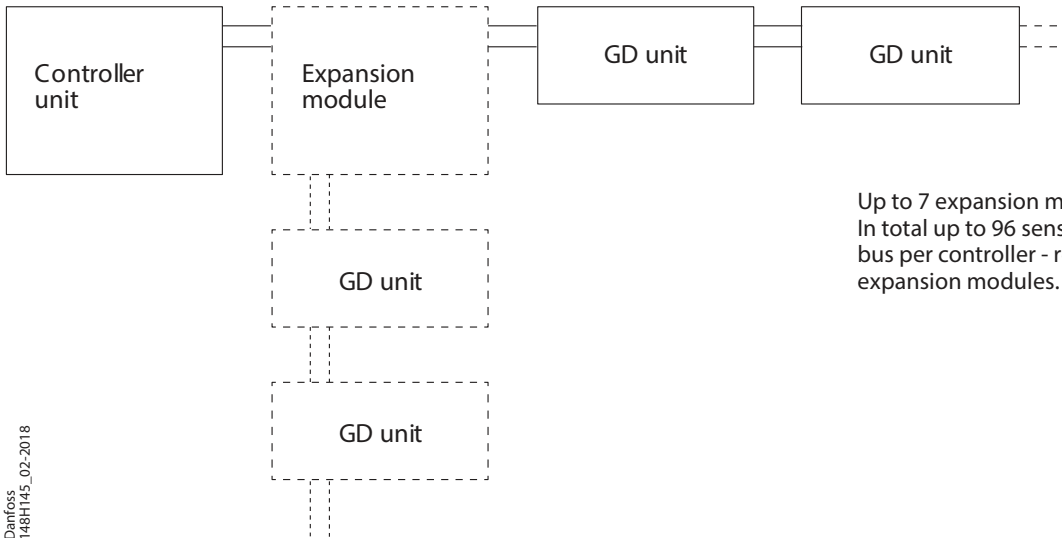

Danfoss
148H145_02-2018

1

Імпортер: ТОВ з іі "Данфосс ТОВ" 04080, Київ 80, п/с 168, Україна

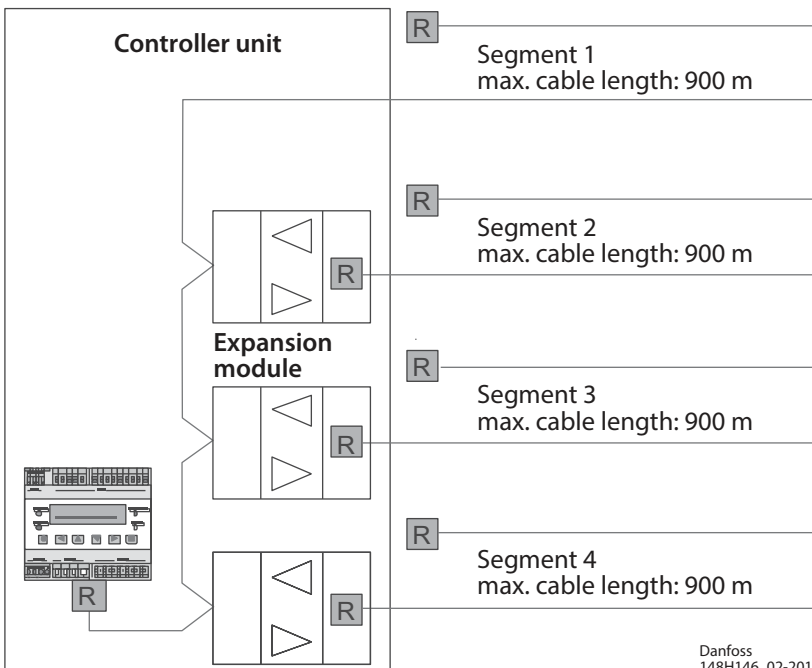

Danfoss
148H146_02-2018

2

Info for UK customers only : Danfoss Ltd., 22 Wycombe End, HP9 1NB, GB

Wiring configuration

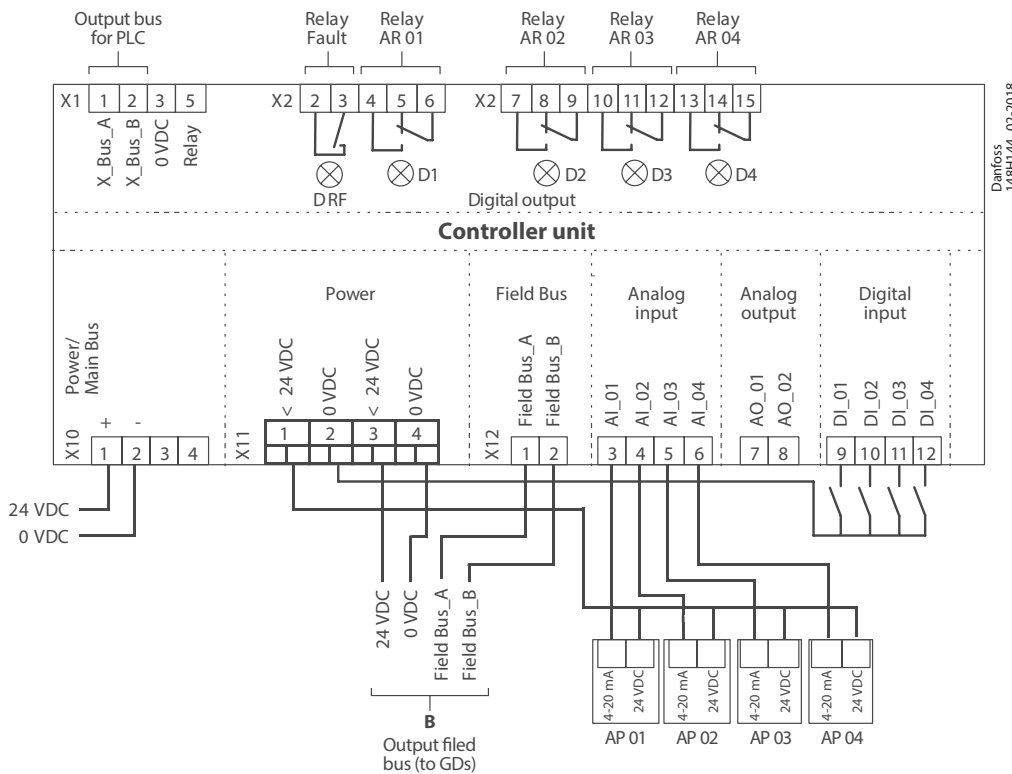

Danfoss
148H144_02-2018

3

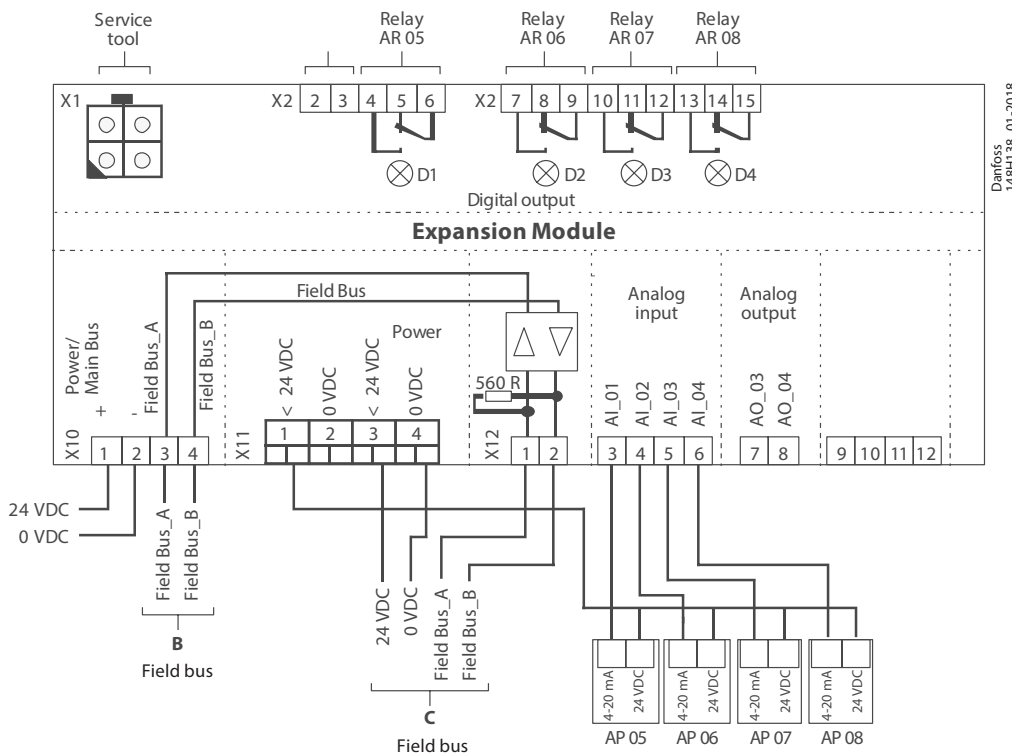

Danfoss
148H138_01-2018

4

Application Intended for Use

The Danfoss gas detection controller unit is controlling one or multiple gas detectors, for monitoring, detection and warning of toxic and combustible gases and vapours in the ambient air. The controller unit meets the requirements according to EN 378, VBG 20 and the guidelines "Safety requirements for ammonia (NH₃) refrigeration systems". The controller can also be used for monitoring other gases and measuring values.

The intended sites are all areas being directly connected to the public low voltage supply, e.g. residential, commercial and industrial ranges as well as small enterprises (according to EN 5502). The controller unit may only be used in ambient conditions as specified in the technical data.

The controller unit must not be used in potentially explosive atmospheres.

Description

The controller unit is a warning and control unit for the continuous monitoring of different toxic or combustible gases and vapours as well as of Freon refrigerants. The controller unit is suitable for the connection of up to 96 digital sensors via the 2-wire bus. Up to 32 analog inputs for the connection of sensors with 4 – 20 mA signal interface are available in addition. The controller unit can be employed as pure analog controller, as analog/digital or as digital controller. The total number of connected sensors, however, may not exceed 128 sensors.

Up to four programmable alarm thresholds are available for each sensor. For binary transmission of the alarms there are up to 32 relays with potential-free change-over contact and up to 96 signal relays.

Comfortable and easy operation of the controller unit is done via the logical menu structure. A number of integrated parameters enables the realisation of various requirements in the gas measuring technique. Configuration is menu-driven via the keypad. For fast and easy configuration, you can use the PC Tool.

Prior to commissioning please consider the guidelines for wiring and commissioning of the hardware.

Normal Mode:

In normal mode, the gas concentrations of the active sensors are continuously polled and displayed at the LC display in a scrolling way. In addition, the controller unit continuously monitors itself, its outputs and the communication to all active sensors and modules.

Alarm Mode:

If the gas concentration reaches or exceeds the programmed alarm threshold, the alarm is started, the assigned alarm relay is activated and the alarm LED (light red for alarm 1, dark red for alarm 2 + n) starts to flash. The set alarm can be read from the menu Alarm Status.

When the gas concentration falls below the alarm threshold and the set hysteresis, the alarm is automatically reset. In latching mode, the alarm must be reset manually directly at the alarm triggering device after falling below the threshold. This function is obligatory for combustible gases detected by catalytic bead sensors generating a falling signal at too high gas concentrations.

Special Status Mode:

In the special status mode there are delayed measurements for the operation side, but no alarm evaluation.

The special status is indicated on the display and it always activates the fault relay.

The controller unit adopts the special status when:

- faults of one or more active devices occur,
- the operation starts up after return of voltage (power on),
- the service mode is activated by the user,
- the user reads or changes parameters,
- an alarm or signal relay is manually overridden in the alarm status menu or via digital inputs.

Fault Mode:

If the controller unit detects an incorrect communication of an active sensor or module, or if an analog signal is outside the admissible range (< 3.0 mA > 21.2 mA), or if there are internal function errors coming from the self-control modules incl. watchdog and voltage control, the assigned fault relay is set and the error LED starts to flash. The error is displayed in the menu Error Status in clear text. After removal of the cause, the error message must be acknowledged manually in the menu Error Status.

Restart Mode (Warm-up Operation):

Gas detection sensors need a running-in period, until the chemical process of the sensor reaches stable conditions. During this running-in period the sensor signal can lead to an unwanted release of a pseudo alarm.

Depending on the connected sensor types, the longest warm-up time must be entered as power-on time in the controller. This power-on time is started at the controller unit after switching on the power supply and/or after the return of voltage. While this time is running out, the gas controller unit does not display any values and does not activate any alarms; the controller system is not yet ready for use.

The power-on status occurs on the first line of the starting menu.

Service Mode:

This operation mode includes commissioning, calibration, testing, repair and decommissioning.

The service mode can be enabled for a single sensor, for a group of sensors as well as for the complete system. In active service mode pending alarms for the concerned devices are held, but new alarms are suppressed.

UPS Functionality (option - additional accessory: Controller solution uptime)

The supply voltage is monitored in all modes. When reaching the battery voltage in the power pack, the UPS function of the controller unit is enabled and the connected battery is charged.

If the power fails, the battery voltage drops down and generates the power failure message.

At empty battery voltage, the battery is separated from the circuit (function of deep discharge protection). When the power is restored, there will be an automatic return to the charging mode.

No settings and therefore no parameters are required for the UPS functionality.

In order to access the user manual and menu overview, please go to further documentation.

Further documentation:



Danfoss A/S

Climate Solutions • danfoss.com • +45 7488 2222

Any information, including, but not limited to information on selection of product, its application or use, product design, weight, dimensions, capacity or any other technical data in product manuals, catalogues descriptions, advertisements, etc. and whether made available in writing, orally, electronically, online or via download, shall be considered informative, and is only binding if and to the extent, explicit reference is made in a quotation or order confirmation. Danfoss cannot accept any responsibility for possible errors in catalogues, brochures, videos and other material. Danfoss reserves the right to alter its products without notice. This also applies to products ordered but not delivered provided that such alterations can be made without changes to form, fit or function of the product.

All trademarks in this material are property of Danfoss A/S or Danfoss group companies. Danfoss and the Danfoss logo are trademarks of Danfoss A/S. All rights reserved.