



VLT® Advanced Harmonic Filter AHF 005/AHF 010

VLT® HVAC Drive FC 102 • VLT® Refrigeration Drive FC 103 VLT® AQUA Drive FC 202 • VLT® AutomationDrive FC 301/302



Contents

1 Introduction

1.1 Purpose of the Design Guide	7
1.2 Document Version	7
1.3 Intended Use	7
1.4 Abbreviations, Symbols, and Conventions	7
1.4.1 Abbreviations	7
1.4.2 Conventions	9
1.4.3 Safety Symbols	9
1.5 Approvals and Certifications	9
1.5.1 Overview of Approvals and Certifications	9
1.5.2 CE Conformity and Labeling	10
1.5.3 CE Mark	10
1.5.3.1 Overview of CE Mark	10
1.5.3.2 Low Voltage Directive	10
1.5.3.3 EMC Directive	10
1.5.3.4 Machinery Directive	11
1.5.3.5 ErP Directive	11
1.5.4 UL Compliance	11
1.6 Safety	11
1.6.1 General Safety Principles	11
1.6.2 Qualified Personnel	11

2 Introduction to Harmonics and Mitigation

2.1 Harmonics and Mitigation	14
2.1.1 Linear Loads	14
2.1.2 Non-linear Loads	14
2.1.3 The Effect of Harmonics in a Power Distribution System	16
2.2 Harmonic Mitigation Standards and Requirements	17
2.2.1 Overview of Harmonic Mitigation Standards and Requirements	17
2.2.2 Application-specific Requirements	17
2.2.3 Harmonic Mitigation Standards	17
2.3 Harmonic Mitigation	19

3 Basic Operating Principle of the AHF

3.1 Operating Principle	21
3.1.1 Overview of Operating Principle	21
3.1.2 Power Factor	23
3.1.3 Capacitive Currents	24
3.2 Energy Efficiency	24

4 Requirements for Installation

4.1 Mechanical Mounting	25
4.1.1 Safety Requirements of Mechanical Installation	25
4.1.2 Mounting Requirements	27
4.1.3 Recommendations for Installation in Industrial Enclosures	28
4.1.4 Ventilation and Cooling Requirements	28
4.1.4.1 Overview of Ventilation and Cooling Requirements	28
4.1.4.2 Requirements for IP20 and IP21/NEMA 1	28
4.2 Electrical Installation	31
4.2.1 Terminals	31
4.2.1.1 Overview of Terminals	31
4.2.1.2 Terminals for Capacitor Disconnect	31
4.2.2 Wiring	33
4.2.2.1 Wiring Recommendations for Paralleling of Frequency Converters	33
4.2.2.2 Wiring Recommendations for Paralleling of Filters	33
4.2.3 Overtemperature Protection	34
4.2.3.1 Overview of Overtemperature Protection	34
4.2.3.2 Programming of Digital Inputs for Overtemperature Protection	34

5 Selection of Advanced Harmonic Filter

5.1 Overview of Selection of Advanced Harmonic Filter	35
5.2 Selecting the Correct AHF	35
5.2.1 Overview of Selecting the Correct AHF	35
5.2.2 Calculation of Correct Filter Size	35
5.2.3 Calculation Example	35
5.2.4 Voltage Boost	36
5.3 Selection Tables	36
5.3.1 Selection Tables terminology	36
5.3.2 Non-Danfoss Contactors	45

5.4 Accessories	45
5.4.1 IP21/NEMA 1 Upgrade Kit	45
5.4.1.1 Overview of IP21/NEMA 1 Upgrade Kit	45
5.4.1.2 IP21/NEMA 1 Upgrade Kit without Built-in Capacitor Disconnect Circuitry	46
5.4.1.3 IP21/NEMA 1 Upgrade Kit with Built-in Capacitor Disconnect Circuitry	46
5.4.2 Backplate for IP20 and IP21	49
6 Programming	
6.1 Parameter Descriptions	50
6.1.1 Overview of Parameter Descriptions	50
6.1.2 Parameter Group 5-0* Digital I/O mode	50
6.1.3 Parameter Group 5-1* Digital Inputs	51
6.1.4 Parameter Group 5-3* Digital Outputs	66
6.1.5 DC-link Compensation Disabling	67
7 Specifications	
7.1 General Specifications	68
7.2 Environmental Data	69
7.3 Power Loss and Acoustic Noise Level	70
7.4 Mechanical Dimensions	76
7.4.1 Overview of Mechanical Dimensions	76
7.4.2 Terminal Specifications	83
7.4.3 IP20 Enclosures	88
7.4.4 IP21 Enclosures	104
7.4.5 Backplate Dimensions	112
7.5 Fuses	114
8 Spare Parts	
8.1 Introduction to Spare Parts	117
8.2 Selection Tables	118
8.2.1 Capacitor Kits	118
8.2.2 Terminal Kits	122
8.2.3 Fan and Fan Accessories, Revisions 01 and 02	125
8.2.4 Fan and Fan Accessories for Revision 03	129
8.2.5 Fuses and Fuse Accessories	140

9 Appendix

9.1 Energy Efficiency	143
9.1.1 Introduction to Energy Efficiency	143
9.1.2 IE and IES Classes	143
9.1.3 Power Loss Data and Efficiency Data	144
9.1.4 Losses and Efficiency of a Motor	145
9.1.5 Losses and Efficiency of a Power Drive System	145
9.1.6 Losses and Efficiency	146
9.1.6.1 Losses and Efficiency of a Power Drive System with Installed Filter	146
9.1.6.2 Calculation Example	147

1 Introduction

1.1 Purpose of the Design Guide

This design guide introduces important aspects of the VLT® Advanced Harmonic Filters AHF 005/AHF 010 (referred to as AHF) for VLT® FC Series frequency converters. It describes harmonics and how to mitigate them, and it provides installation instructions and guidance on how to program the frequency converter.

The technical data and information on the connection conditions are on the nameplate and in the documentation.

Always observe the recommendations and instructions in this document.

Danfoss technical documentation is also available online at danfoss.com.

1.2 Document Version

This manual is regularly reviewed and updated. All suggestions for improvement are welcome.

[Table 1](#) shows the document version.

Table 1: Document Version

Edition	Remarks
AJ315930123484, document version 06	<ul style="list-style-type: none"> Updated selection table for upgrade kit with built-in capacitor disconnect circuitry. Updated selection for filters in 600 V and 690 V applications. Transformer for fan control added. Danfoss disconnectors removed. Use of soft charge disconnectors in 690 V applications.

1.3 Intended Use

The filters are components designed for installation in electrical systems or machinery.

When installing in machines, commissioning of the filters (that is starting of operation as directed) is prohibited until it is proven that the machine complies with the Machinery Directive 2006/42/EC. Observe EN 60204.

The VLT® Advanced Harmonic Filter AHF 005/AHF 010 is intended for use with:

- VLT® HVAC Drive FC 102
- VLT® Refrigeration Drive FC 103
- VLT® AQUA Drive FC 202
- VLT® AutomationDrive FC 301/FC 302

1.4 Abbreviations, Symbols, and Conventions

1.4.1 Abbreviations

Table 2: Abbreviations

°C	Degrees Celsius
°F	Degrees Fahrenheit
A	Ampere/AMP
AC	Alternating current
AHF	Advanced Harmonic Filter
AWG	American wire gauge

Table 2: Abbreviations - (continued)

CDM	Complete drive module
DC	Direct current
DPF	Displacement power factor
EMC	Electromagnetic compatibility
$f_{M,N}$	Nominal motor frequency
FC	Frequency converter
g	Ground gravity
HCS	Harmonic calculation software
$I_{M,N}$	Nominal motor current
I_{INV}	Rated inverter output current
Hz	Hertz
kHz	Kilohertz
kVAr	Kilo-volt-ampere reactive
LCP	Local control panel
m	Meter
mA	Milliampere
MCT	Motion control tool
mH	Millihenry inductance
min	Minute
ms	Millisecond
nF	Nanofarad
Nm	Newton meter
P	Active power
PCC	Point of common coupling
PDS	Power drive system
PELV	Protective extra low voltage
PF	Power factor
$P_{M,N}$	Nominal motor power
PWHD	Partial weighted harmonic distortion
Q	Reactive power
R_{SCE}	Short circuit ratio
RPM	Revolutions per minute
S	Apparent power
s	Second
TDD	Total demand distortion
THD	Total harmonic distortion
THD_i	Total harmonic current distortion

Table 2: Abbreviations - (continued)

THD _v	Total harmonic voltage distortion
TPF	True power factor
U _{M,N}	Nominal motor voltage
V	Volts

1.4.2 Conventions

- Numbered lists indicate procedures.
- Bulleted and dashed lists indicate listings of other information where the order of the information is not relevant.
- Bolded text indicates important information and section headings.
- Italicized text indicates the following:
 - Cross-reference.
 - Link.
 - Footnote.
 - Alarms/warnings
- Bolded and italicized text indicates the following:
 - Parameter name.
 - Parameter option.
 - Parameter group name.
- All dimensions in drawings are in metric values (imperial values in brackets).
- An asterisk (*) indicates the default setting of a parameter.

1.4.3 Safety Symbols

The following symbols are used in this guide:



DANGER

Indicates a hazardous situation which, if not avoided, will result in death or serious injury.



WARNING

Indicates a hazardous situation which, if not avoided, could result in death or serious injury.



CAUTION

Indicates a hazardous situation which, if not avoided, could result in minor or moderate injury.

NOTICE

Indicates information considered important, but not hazard-related (for example, messages relating to property damage).

1.5 Approvals and Certifications

1.5.1 Overview of Approvals and Certifications

VLT® Advanced Harmonic Filters AHF 005/AHF 010 are designed in compliance with the directives described in this section.

More approvals and certifications are available. Contact a local Danfoss partner.

1.5.2 CE Conformity and Labeling

The purpose of CE labeling is to avoid technical trade obstacles within EFTA and the EU. The EU has introduced the CE label as a simple way of showing whether a product complies with the relevant EU Directives and standards. The CE label says nothing about the specifications or quality of the product.

1.5.3 CE Mark

1.5.3.1 Overview of CE Mark



Figure 1: CE mark

The CE mark (Communauté Européenne) indicates that the product manufacturer conforms to all applicable EU Directives. The EU Directives applicable to the design and manufacture of drives are listed in [Table 3](#).

NOTICE

The CE mark does not regulate the quality of the product. Technical specifications cannot be deduced from the CE mark.

Table 3: EU Directives Applicable to Drives

EU directive	Version
Low Voltage Directive	2014/35/EU
EMC Directive	2014/30/EU
Machinery Directive ⁽¹⁾	2014/42/EU
ErP Directive	2009/125/EU
ATEX Directive	2014/34/EU
RoHS Directive	2011/65/EU

1) Machinery Directive conformance is only required for drives with an integrated safety function.

Declarations of conformity are available on request.

1.5.3.2 Low Voltage Directive

Drives are classified as electronic components and must be CE-labeled in accordance with the Low Voltage Directive. The directive applies to all electrical equipment in the 50–1000 V AC and the 75–1500 V DC voltage ranges.

The directive mandates that the equipment design must ensure the safety and health of people and livestock, and the preservation of material by ensuring the equipment is properly installed, maintained, and used as intended. Danfoss CE labels comply with the Low Voltage Directive, and Danfoss provides a declaration of conformity upon request.

1.5.3.3 EMC Directive

The purpose of the EMC (electromagnetic compatibility) Directive is to reduce electromagnetic interference and enhance immunity of electrical equipment and installations. The basic protection requirement of the EMC Directive states that devices that generate electromagnetic interference (EMI), or whose operation could be affected by EMI, must be designed to limit the generation of electromagnetic interference and shall have a suitable degree of immunity to EMI when properly installed, maintained, and used as intended. Electrical equipment devices used alone or as part of a system must bear the CE mark. Systems do not require the CE mark, but must comply with the basic protection requirements of the EMC Directive.

1.5.3.4 Machinery Directive

The aim of the Machinery Directive is to ensure personal safety and avoid property damage to mechanical equipment used in its intended application. The Machinery Directive applies to a machine consisting of an aggregate of interconnected components or devices of which at least 1 is capable of mechanical movement. Drives with an integrated functional safety function must comply with the Machinery Directive. Drives without a functional safety function do not fall under the Machinery Directive. If a drive is integrated into a machinery system, Danfoss can provide information on safety aspects relating to the drive. When drives are used in machines with at least 1 moving part, the machine manufacturer must provide a declaration stating compliance with all relevant statutes and safety measures.

1.5.3.5 ErP Directive

The ErP directive is the European Ecodesign Directive for energy-related products. The directive sets ecodesign requirements for energy-related products, including frequency converters. The directive aims at increasing energy efficiency and the level of protection of the environment, while increasing the security of the energy supply. Environmental impact of energy-related products includes energy consumption throughout the entire product life cycle.

The RCM Mark label indicates compliance with the applicable technical standards for electromagnetic compatibility (EMC). An RCM Mark label is required for placing electrical and electronic devices on the market in Australia and New Zealand. The RCM Mark regulatory arrangements only deal with conducted and radiated emission. For frequency converters, the emission limits specified in EN/IEC 61800-3 apply. A declaration of conformity can be provided on request.

1.5.4 UL Compliance



Figure 2: UL

NOTICE

The VLT® Advanced Harmonic Filter AHF 005/AHF 010 460 V/60 Hz and 600 V/60 Hz types are UL-listed at UL file no. E134261 (NMMS.E134261).

1.6 Safety

1.6.1 General Safety Principles

If handled improperly, drives have the potential for fatal injury as they contain high-voltage components. Only qualified personnel are allowed to install and operate the equipment. Do not attempt repair work without first removing power from the drive and waiting the designated amount of time for stored electrical energy to dissipate.

Strict adherence to safety precautions and notices is mandatory for safe operation of the drive and filter.

1.6.2 Qualified Personnel

Correct and reliable transport, storage, installation, operation, and maintenance are required for the trouble free and safe operation of the filter. Only qualified personnel are allowed to install or operate this equipment.

Qualified personnel are defined as trained staff, who are authorized to install, commission, and maintain equipment, systems, and circuits in accordance with pertinent laws and regulations. Also, the qualified personnel must be familiar with the instructions and safety measures described in this manual.

WARNING



IMPROPER INSTALLATION

Improper installation of the filter or the frequency converter may cause death, serious injury, or equipment failure.

- Follow this design guide and install according to National and Local Electrical Codes.

WARNING



HIGH VOLTAGE

Filters contain high voltage when connected to AC mains input. Failure to perform installation, start-up, and maintenance by qualified personnel can result in death or serious injury.

- Only qualified personnel must perform installation, start-up, and maintenance.
- Never work on a filter in operation.

WARNING



DISCHARGE TIME

The VLT® Advanced Harmonic Filters AHF 005/AHF 010 contain capacitors. The capacitors can remain charged even when the filter is not powered. Failure to wait the specified time after power has been removed before performing service or repair work can result in death or serious injury.

- Stop the frequency converter and the motor.
- Disconnect AC mains, permanent magnet type motors, remote DC-link supplies including battery back-ups, UPS, and DC-link connections to other frequency converters.
- Wait the required time specified on the nameplate, ensuring that the capacitors are discharged fully, before performing any service or repair work on the filter.
- Before performing any service or repair work on the filter, ensure that the voltage is 0 between the filter terminals X3.1, X3.2, and X3.3, and between the filter terminals X4.1, X4.2, and X4.3.

WARNING



ELECTRICAL HAZARD

When measuring on live filters, observe the valid national regulations for the prevention of accidents (for example VBG 4).

The electrical installation must be carried out according to the appropriate regulations (for example, cable cross sections, fuses, and PE connection). When using the filters with frequency converters without safe separation from the supply line (to VDE 0100), include all control wiring in further protective measures (for example, double insulated or shielded, grounded, and insulated). Improper installation of the filter may cause electrical shock injury.

CAUTION



HOT SURFACE

When in use, the filter surface becomes hot.

- Do not touch the filter during operation.

 CAUTION



OVERTEMPERATURE

Overtemperature damages the filter chokes. To prevent overtemperature:

- Use temperature switches, see [4.2.3.1 Overview of Overtemperature Protection](#).
- Perform an immediate stop or a controlled ramp down within 30 s.

 CAUTION



PROTECTIVE DEVICES

Equip systems where filters are installed with extra monitoring and protective devices according to the valid safety regulations, for example, rules on technical tools and regulations for the prevention of accidents.

 CAUTION



Non-authorized removal of required cover, inappropriate use, incorrect installation, or operation create the risk of severe injury to persons or damage to material assets.

- To avoid the risk, only let authorized and qualified personnel handle the VLT® Advanced Harmonic Filter AHF 005/AHF 010.

NOTICE

The filters shown in this design guide are specially designed and tested for operation with Danfoss frequency converters, see [1.3 Intended Use](#). Danfoss takes no responsibility for the use of the filters with third-party frequency converters.

NOTICE

REPAIR OF FILTER

Only Danfoss authorized, qualified personnel are allowed to repair the VLT® Advanced Harmonic Filter AHF 005/AHF 010. See *chapter 8 Spare Parts* for more details.

NOTICE

Commissioning is only allowed when there is compliance with the EMC Directive 2014/30/EU.

The filters meet the requirements of the Low Voltage Directive 2014/35/EU.

NOTICE

Protect the filter from inappropriate loads, particularly during transport and handling. Components are not allowed to be bent. Do not alter the distance in between isolation. Avoid touching electronic components and contacts.

2 Introduction to Harmonics and Mitigation

2.1 Harmonics and Mitigation

2.1.1 Linear Loads

On a sinusoidal AC supply, a purely resistive load, such as an incandescent light bulb, draws a sinusoidal current in phase with the supply voltage. The power dissipated by the load is:

$$P = U \cdot I$$

For reactive loads, such as an induction motor, the current is no longer in phase with the voltage, but lags the voltage creating a lagging true power factor with a value less than 1. In the case of capacitive loads, the current is in advance of the voltage, creating a leading true power factor with a value less than 1.

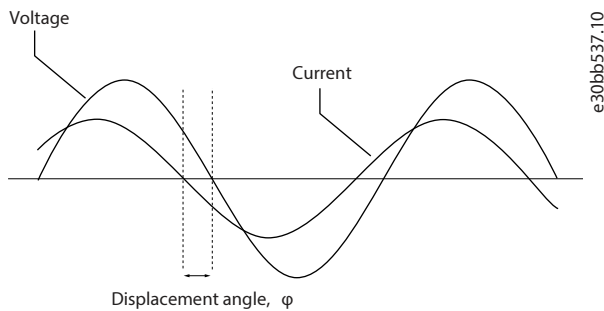

Figure 3: Current Creating a True Power Factor

In this case, the AC power has 3 components:

- Real power (P)
- Reactive power (Q)
- Apparent power (S)

The apparent power is:

$$S = U \cdot I$$

where S = [kVA], P = [kW], and Q = [kVAR]

In the case of a perfectly sinusoidal waveform, P, Q, and S can be expressed as vectors that form a triangle:

$$S^2 = P^2 + Q^2$$

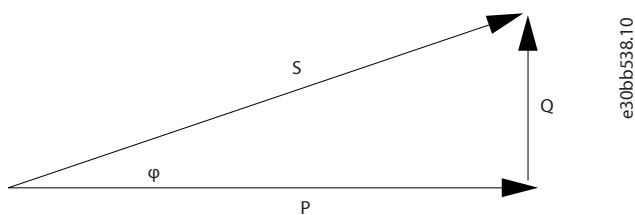

Figure 4: Sinusoidal Waveform

The displacement angle between current and voltage is φ. The displacement power factor is the ratio between the active power (P) and apparent power (S):

$$DPF = \frac{P}{S} = \cos(\Phi)$$

2.1.2 Non-linear Loads

Non-linear loads (such as diode rectifiers) draw a non-sinusoidal current. The current drawn by a 6-pulse rectifier on a 3-phase supply is shown in [Figure 5](#).

A non-sinusoidal waveform can be decomposed in a sum of sinusoidal waveforms with periods equal to integer multiples of the fundamental waveform.

$$f(t) = \sum a_h \cdot \sin(h \cdot \omega_1 \cdot t)$$

See [Figure 5](#).

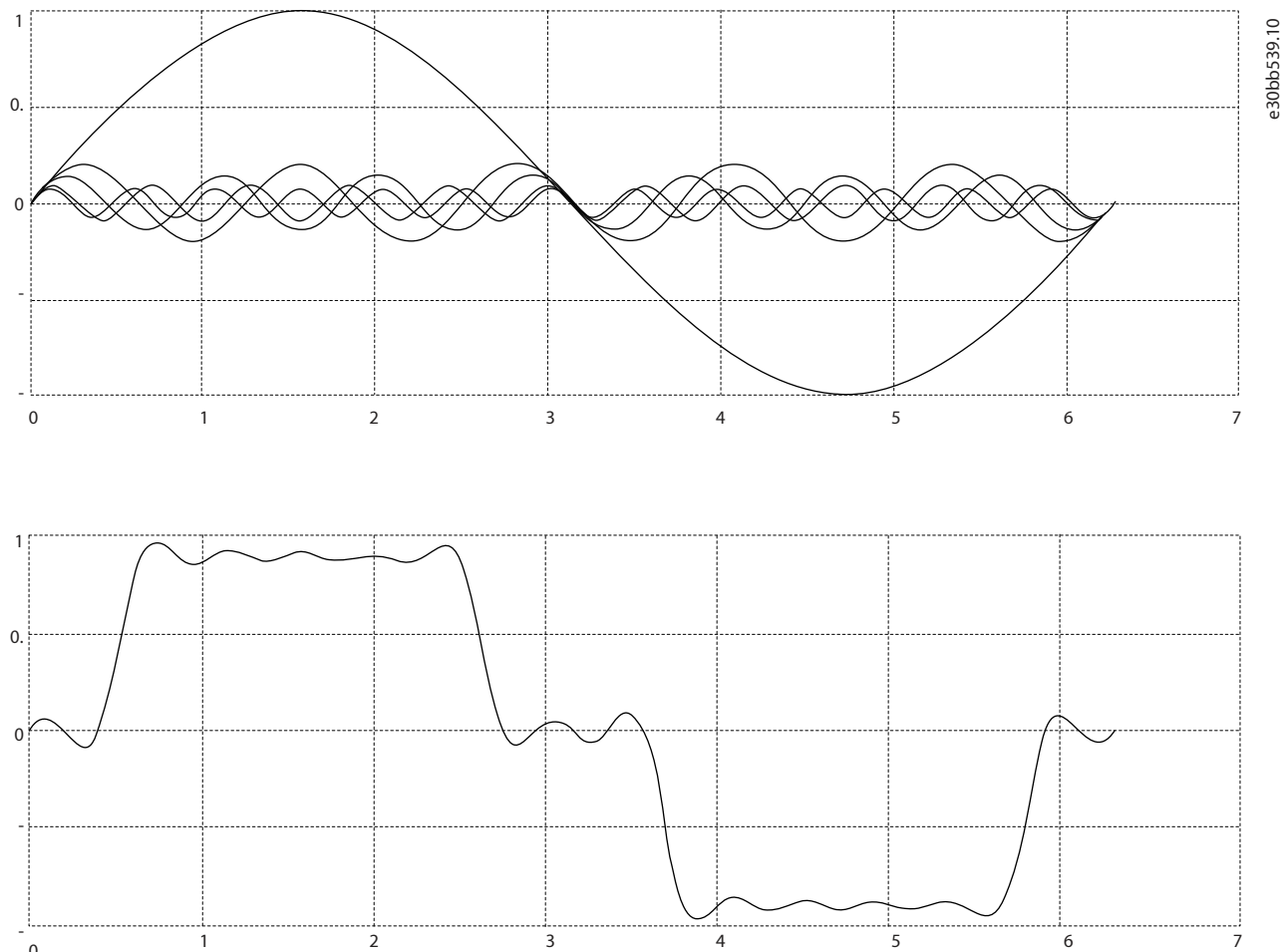

Figure 5: Sinusoidal Waveforms

The integer multiples of the fundamental frequency ω_1 are called harmonics. The RMS value of a non-sinusoidal waveform (current or voltage) is expressed as:

$$I_{RMS} = \sqrt{\sum_{h=1}^{h_{max}} I_h^2}$$

The amount of harmonics in a waveform gives the distortion factor, or total harmonic distortion (THD), represented by the ratio of RMS of the harmonic content to the RMS value of the fundamental quantity, expressed as a percentage of the fundamental:

$$THD = \sqrt{\sum_{h=2}^{h_{max}} \left(\frac{I_h}{I_1}\right)^2} \cdot 100\%$$

Using the THD, the relationship between the RMS current I_{RMS} and the fundamental current I_1 can be expressed as:

$$I_{RMS} = I_1 \cdot \sqrt{1 + THD^2}$$

The same applies for voltage. The true power factor PF (λ) is:

$$PF = \frac{P}{S}$$

In a linear system the true power factor is equal to the displacement power factor:

PF = DPF = cos (φ)

In non-linear systems the relationship between true power factor and displacement power factor is:

$$PF = \frac{DPF}{\sqrt{1 + THD^2}}$$

The power factor is decreased by reactive power and harmonic loads. Low power factor results in a high RMS current that produces higher losses in the supply cables and transformers. In the power quality context, the total demand distortion (TDD) term is often encountered. The TDD does not characterize the load, but it is a system parameter. TDD expresses the current harmonic distortion in percentage of the maximum demand current I_L .

$$TDD = \sqrt{\sum_{h=2}^{h_{max}} \left(\frac{I_h}{I_L}\right)^2} \cdot 100\%$$

Another term often encountered in literature is the partial weighted harmonic distortion (PWHd). PWHd represents a weighted harmonic distortion that contains only the harmonics between the 14th and the 40th, as shown in the following definition.

$$PWHd = \sqrt{\sum_{h=14}^{40} \left(\frac{I_h}{I_1}\right)^2} \cdot 100\%$$

2.1.3 The Effect of Harmonics in a Power Distribution System

In [Figure 6](#), a transformer is connected on the primary side to a point of common coupling PCC1 on the medium voltage supply. The transformer has an impedance Z_{xfr} and feeds several loads. The point of common coupling where all loads are connected together is PCC2. Each load is connected through cables that have an impedance Z_1, Z_2, Z_3 .

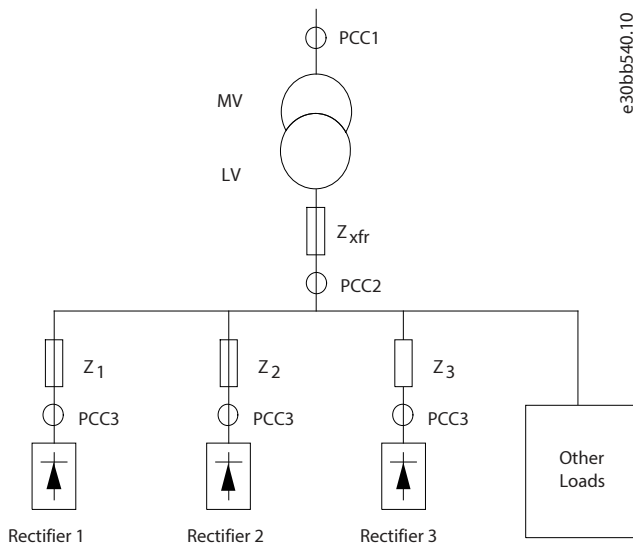

Figure 6: Small Distribution System

Harmonic currents drawn by non-linear loads cause distortion of the voltage because of the voltage drop on the impedances of the distribution system. Higher impedances result in higher levels of voltage distortion.

Current distortion relates to apparatus performance and it relates to the individual load. Voltage distortion relates to system performance. It is not possible to determine the voltage distortion in the PCC knowing only the load’s harmonic performance. To predict the distortion in the PCC, the configuration of the distribution system and relevant impedances must be known.

A commonly used term for describing the impedance of a grid is the short circuit ratio R_{sce} . This ratio is defined as the ratio between the short circuit apparent power of the supply at the PCC (S_{sc}) and the rated apparent power of the load (S_{equ}).

$$R_{sce} = \frac{S_{sc}}{S_{equ}}$$

where

$$S_{sc} = \frac{U^2}{Z_{supply}} \text{ and } S_{equ} = U \cdot I_{equ}$$

The negative effect of harmonics is twofold

- Harmonic currents contribute to system losses (in cabling, transformer).
- Harmonic voltage distortion causes disturbance to other loads and increases losses in other loads.

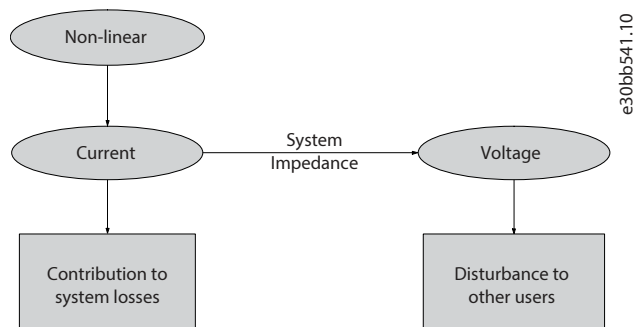

Figure 7: Negative Effects of Harmonics

2.2 Harmonic Mitigation Standards and Requirements

2.2.1 Overview of Harmonic Mitigation Standards and Requirements

The requirements for harmonic limitation can be:

- Application-specific requirements.
- Requirements from standards that have to be observed.

2.2.2 Application-specific Requirements

The application-specific requirements are related to a specific installation where there are technical reasons for limiting the harmonics.

Example

Two 110 kW motors are connected to a 250 kVA transformer. One motor is connected direct online, and the other is supplied through a frequency converter. If the direct online motor should also be supplied through a frequency converter, the transformer is, in this case, undersized. To retrofit without changing the transformer, mitigate the harmonic distortion from the 2 frequency converters by using VLT® Advanced Harmonic Filters AHF 005/AHF 010.

2.2.3 Harmonic Mitigation Standards

There are various harmonic mitigation standards, regulations, and recommendations. Different standards apply in different geographical areas and industries. The following encountered standards are presented:

- IEC/EN 61000-3-2
- IEC/EN 61000-3-12
- IEC/EN 61000-3-4
- IEC 61000-2-2
- IEC 61000-2-4
- IEEE 519
- G5/4

Table 4: Harmonics Mitigation Standards

Number of standard	Title	Scope	Comments
IEC 61000-3-2	Limits for harmonic current emissions (equipment input current ≤ 16 A per phase).	Equipment connected to the public low-voltage distribution system having an input current up to and including 16 A per phase.	VLT® drives are in Class A. There are no limits for professional equipment with a total rated power >1 kW.
IEC 61000-3-12	Limits for harmonic currents produced by equipment connected to public low-voltage systems with input current >16 A and ≤ 75 A.	Equipment connected to the public low-voltage distribution system having an input current >16 A and ≤ 75 A.	The emission limits are currently only for 230/400 V 50 Hz systems. There are requirements for individual harmonics (5th, 7th, 11th, and 13th) and for THD ⁽¹⁾ and PWHD ⁽²⁾ . All drives listed in 1.3 Intended Use comply with these limits without extra filtering.
IEC 61000-3-4	Limits, limitation of emission of harmonic currents in low-voltage supply systems for equipment with rated current >16 A.	Equipment with rated current >75 A connected to the public low-voltage distribution system.	A 3-stage assessment procedure is described for the connection of equipment to the public supply. Equipment >75 A is limited to stage 3 <i>Connection based on the load's agreed power</i> . The supply authority may accept the connection of the equipment based on the agreed active power of the load's installation and local requirements of the supply authority apply. The manufacturer shall provide individual harmonics and the values for THD and PWHD.
IEC 61000-2-2/ IEC 61000-2-4	Compatibility levels for low-frequency conducted disturbances.	Stipulation of compatibility levels for low-frequency conducted disturbances in public low-voltage supply systems (IEC 61000-2-2) and industrial plants (IEC 61000-2-4).	Low-frequency disturbances include but are not limited to harmonics. Consider the values prescribed in the standards when planning installations.

Table 4: Harmonics Mitigation Standards - (continued)

Number of standard	Title	Scope	Comments
IEEE 519	IEEE-recommended practices and requirements for harmonic control in electrical power systems.	Control of the voltage distortion at the PCC to a TDD of 5% and limitation of the maximum individual frequency voltage harmonic to 3%.	Establishment of goals for the design of electrical systems that include both linear and non-linear loads. Waveform distortion goals are established, and the interface between sources and loads is described as point of common coupling (PCC). The current distortion limits depend on the ratio I_{SC}/I_L where I_{SC} is the short-circuit current at the utility PCC and I_L is the maximum demand load current. The limits are given for individual harmonics up to the 35th and total demand distortion (TDD). The most effective way to meet the harmonic distortion requirements is to mitigate at the individual loads and measure at the PCC.
G5/4	Engineering recommendation, planning levels for harmonic voltage distortion, and the connection of non-linear equipment to transmission systems and distribution networks in the United Kingdom.	Setting planning levels for harmonic voltage distortion to be used in the process of connecting non-linear equipment. A process for establishing individual customer emission limits based on these planning levels is described.	G5/4 is a system level standard. For 400 V, the voltage THD planning level is 5% at the PCC. Limits for odd and even harmonics in 400 V systems are given in Table 4 . The standard describes a 3-stage assessment procedure for the connection of non-linear equipment. The procedure aims at balancing the level of detail required by the assessment process with the degree of risk that the connection of particular equipment results in unacceptable voltage harmonic distortion. Compliance of a system containing VLT drives depends on the specific topology and population of non-linear loads. To meet the requirements of G5/4, employ AHF 005/AHF 010.

1) New definitions are introduced through IEC/EN 61000-3-12:2011 which means that THD is replaced by THC/I_{ref} .

2) New definitions are introduced through IEC/EN 61000-3-12:2011 which means that PWHF is replaced by $PWHC/I_{ref}$.

2.3 Harmonic Mitigation

There are several ways of mitigating the harmonics caused by the frequency converter 6-pulse rectifier, and they all have their advantages and disadvantages.

Selecting the right solution depends on several factors:

- The grid (background distortion, mains unbalance, resonance, and type of supply transformer/generator).
- Application (load profile, number of loads, and load size).
- Local/national requirements/regulations (for example, IEEE 519, IEC, and ER G5/4).
- Total cost of ownership (for example initial cost, efficiency, and maintenance).

IEC standards are harmonized by various countries or supra-national organizations. All above-mentioned IEC standards are harmonized in the European Union with the prefix "EN". For example, the European EN 61000-3-2 is the same as IEC 61000-3-2. The situation is similar in Australia and New Zealand, with the prefixes AS/NZS.

Categories of harmonic solutions:

- Passive
- Active

Passive solutions consist of capacitors, inductors, or a combination of the 2 in different arrangements.

The simplest solution is to add inductors/reactors of typically 3–5% in front of the frequency converter. This added inductance reduces the number of harmonic currents produced by the frequency converter. More advanced passive solutions combine capacitors and inductors in trap arrangement specially tuned to eliminate harmonics starting from, for example, the 5th harmonic.

The active solutions determine the exact current that cancels the harmonics present in the circuit and synthesizes and injects that current into the system. Thus, the active solution mitigates the real-time harmonic disturbances, which makes these solutions effective at any load profile. For more details on the Danfoss active solutions, refer to VLT® Low Harmonic Drive Operating Instructions and VLT® Advanced Active Filter AAF 006 Operating Instructions.

3 Basic Operating Principle of the AHF

3.1 Operating Principle

3.1.1 Overview of Operating Principle

The VLT® Advanced Harmonic Filter AHF 005/AHF 010 consists of a main inductor L_0 and a 2-stage absorption circuit with the inductors L_1 and L_2 , and the capacitors C_1 and C_2 . The absorption circuit is specially tuned to eliminate harmonics starting with the 5th harmonic and is specific for the designed supply frequency. Therefore, the circuit for 50 Hz has different parameters than the circuit for 60 Hz.

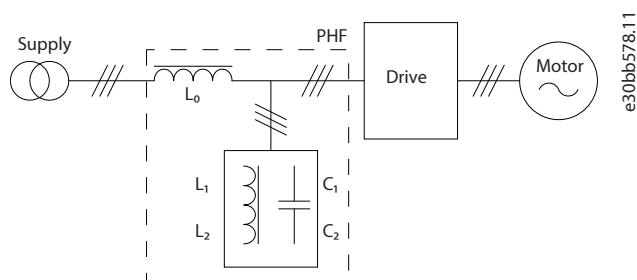

Figure 8: Operating Principle

AHFs are available in 2 variants for 2 performance levels:

- AHF 005 with 5% THDi.
- AHF 010 with 10% THDi.

Each of the 2 variants is available with the following voltages:

- 380–415 V, 50 Hz.
- 380–415 V, 60 Hz.
- 440–480 V, 60 Hz.
- 600 V, 60 Hz.
- 500–690 V, 50 Hz.

The AHF 010 offers a performance similar to 12-pulse rectifiers, and the AHF 005 offers a performance similar to 18-pulse rectifiers.

The filter performance in terms of THDi varies as a function of the load. At nominal load, the filter performance is better than 10% THDi for AHF 010 and 5% THDi for AHF 005.

At part load, the THDi has higher values. However, the absolute value of the harmonic current is lower at part loads, even if the THDi has a higher value. Therefore, the negative effect of the harmonics at part loads is lower than at full load.

Example of part load

An 18.5 kW (25 hp) drive is installed on a 400 V/50 Hz grid with a 34 A AHF 010 (type code AHFDA- 34-400-50-20-A).

The values in [Table 5](#) are measured for different load currents, using a harmonic analyzer.

Table 5: Example of Load Currents

I_{line} RMS [A]	Basic current at 50 Hz I RMS [A]	THDi [%]	Total harmonic current I_h RMS [A]
9.6	9.59	5.45	0.52
15.24	15.09	13.78	2.07
20.24	20.08	12.46	2.5
25.17	25	11.56	2.89

Table 5: Example of Load Currents - (continued)

I_{line} RMS [A]	Basic current at 50 Hz I RMS [A]	THDi [%]	Total harmonic current I_h RMS [A]
30.27	30.1	10.5	3.15
34.2	34.03	9.95	3.39

1) The total harmonic current has been calculated. The THDi versus load plot is shown in [Figure 9](#).

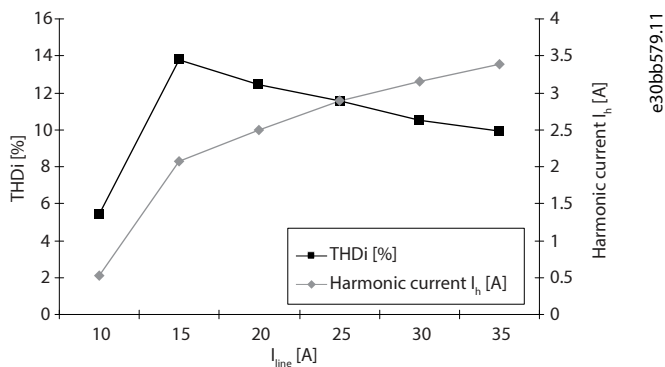

Figure 9: THDi Versus Load

At part load, 15 A, the THDi is approximately 14% compared to 10% at the nominal load of 34 A. At the same time, the total harmonic current is only 2.07 A at 15 A line current against 3.39 A harmonic current at 3 A line current. Thus, THDi is only a relative indicator of the harmonic performance. The harmonic distortion of the voltage is less at part load than at nominal load.

Background distortion

Factors such as background distortion and grid unbalance can affect the performance of AHF filters. The specific figures are different from filter to filter, and [Figure 10](#) to [Figure 13](#) show typical performance characteristics. For specific details, use a harmonic design tool such as MCT 31 or Harmonic Calculation Software (HCS).

The design of the filters aims to achieve 10%, respectively, 5% THDi levels with a background distortion of THDv = 2%. Practical measurements on typical grid conditions in AC drive installations often show that the performance of the filter is slightly better with a 2% background distortion. However, the complexity of the grid conditions and the mix of specific harmonics does not provide a general rule about the performance on a distorted grid. [Figure 10](#) and [Figure 11](#) show worst-case performance deterioration characteristics with the background distortion.

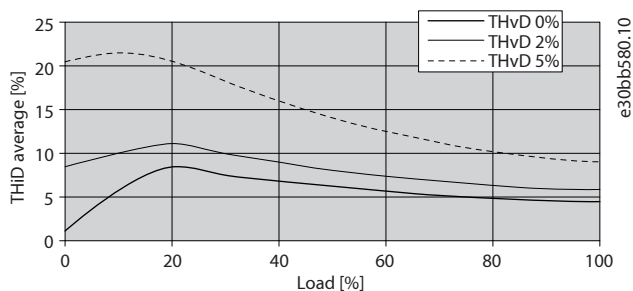

Figure 10: AHF 005

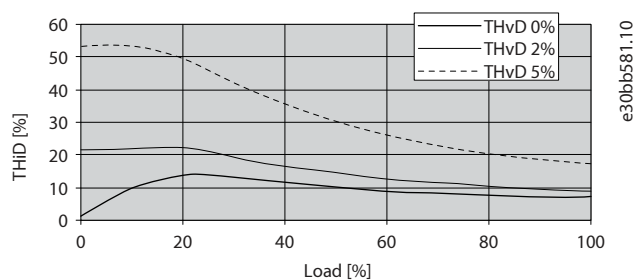

Figure 11: AHF 010

Performance at 10% THDv has not been plotted. However, the filters have been tested and can operate at 10% THDv, but the filter performance can no longer be guaranteed.

The filter performance also deteriorates with the unbalance of the supply. Typical performance is shown in [Figure 12](#) and [Figure 13](#).

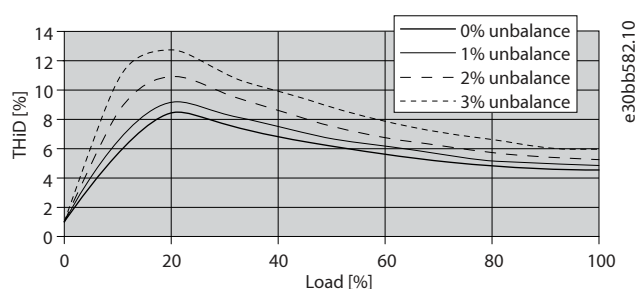

Figure 12: AHF 005

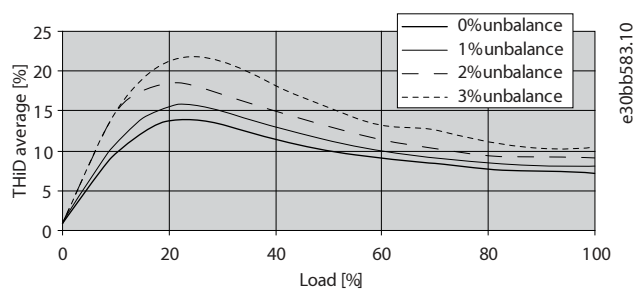

Figure 13: AHF 010

3.1.2 Power Factor

In no-load conditions (the drive is in stand-by), the drive current is negligible, and the main current drawn from the grid is the current through the capacitors in the harmonic filter. Therefore, the power factor is close 0, capacitive. The capacitive current is approximately 25% of the filter nominal current (depends on filter size, typical values of 20–25%). The power factor increases with the load. Because of the higher value of the main inductor L_0 in the VLT® Advanced Harmonic Filter AHF 005, the power factor is slightly higher than in the VLT® Advanced Harmonic Filter AHF 010.

[Figure 14](#) and [Figure 15](#) show typical values for the true power factor on AHF 010 and AHF 005.

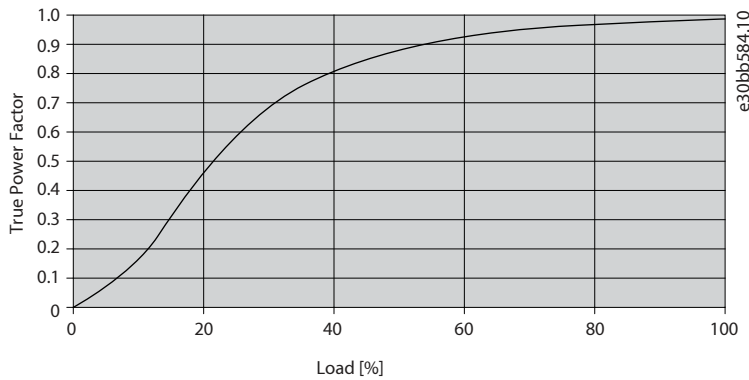

Figure 14: AHF 005

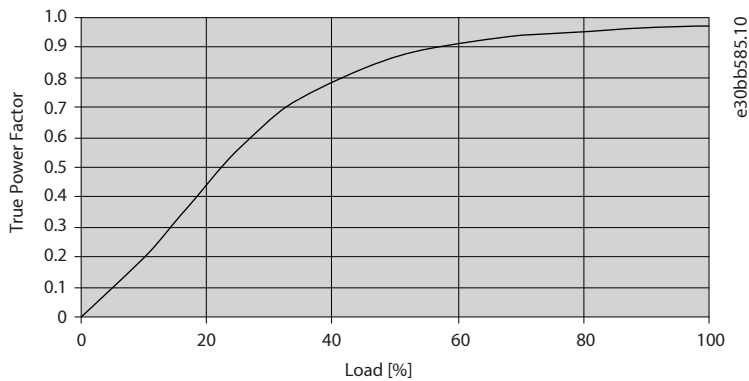

Figure 15: AHF 010

3.1.3 Capacitive Currents

If the specific application requires a higher power factor at no-load and a reduction of the capacitive current in standby, use a capacitor disconnect. A contactor disconnects the capacitor at loads below 20%.

NOTICE

It is important to note that the capacitors must not be connected at full load or disconnected at no load.

It is important to consider the capacitive current in the design of applications where the harmonic filter is supplied by a generator. The capacitive current can cause overvoltage of the generator in no-load and low-load conditions. The overvoltage causes an increase of the voltage, which then may exceed the allowed voltage for the filter and the drive. Therefore, always use a capacitor disconnect in generator applications and consider the design carefully. For more information about capacitive currents, refer to [4.2.1.2 Terminals for Capacitor Disconnect](#).

Compared to multi-pulse rectifiers, passive harmonic filters (such as VLT® Advanced Harmonic Filter AHF 005/AHF 010) are more robust against background distortion and supply imbalance. However, the performance of passive filters is inferior to the performance of active filters in part load performance and power factor. For details about the performance positioning of the various harmonic mitigation solutions offered by Danfoss, consult the relevant harmonic mitigation manuals.

3.2 Energy Efficiency

For energy efficiency calculations see [9.1.1 Introduction to Energy Efficiency](#).

4 Requirements for Installation

4.1 Mechanical Mounting

4.1.1 Safety Requirements of Mechanical Installation

WARNING	
	<p>HEAVY LOAD</p> <p>Unbalanced loads can fall and loads can tip over. Failure to take proper lifting precautions increases risk of death, serious injury, or equipment damage.</p> <ul style="list-style-type: none"> • Never walk under suspended loads. • Wear personal protective equipment. • Observe the weight of the unit and ensure that proper lifting equipment is used. • The center of gravity can be in an unexpected area. If that is not observed, the unit can fall over or tilt unexpectedly during lifting and transport. Check the center of gravity, before lifting the load. • When installing the filter, use the lifting eyes on both sides to lift the filter.

Lift the filters using the dedicated lifting eyes. For enclosure X3-V3 to X8-V3 extra lifting eyes are placed in the centerline.

CAUTION	
	<p>For filters with external fan, place hooks in the lifting eyes to lift the unit. Do not attempt to use lifting bars or other methods with equipment going through the lifting eyes, since this could harm the fan.</p>

CAUTION	
	<p>Do not lift the unit with the IP 21/NEMA 1 kit top cover mounted. This could damage the top cover or compromise the safety during lifting.</p>

[Figure 16](#) and [Figure 17](#) show the recommended lifting methods for the different AHF types.

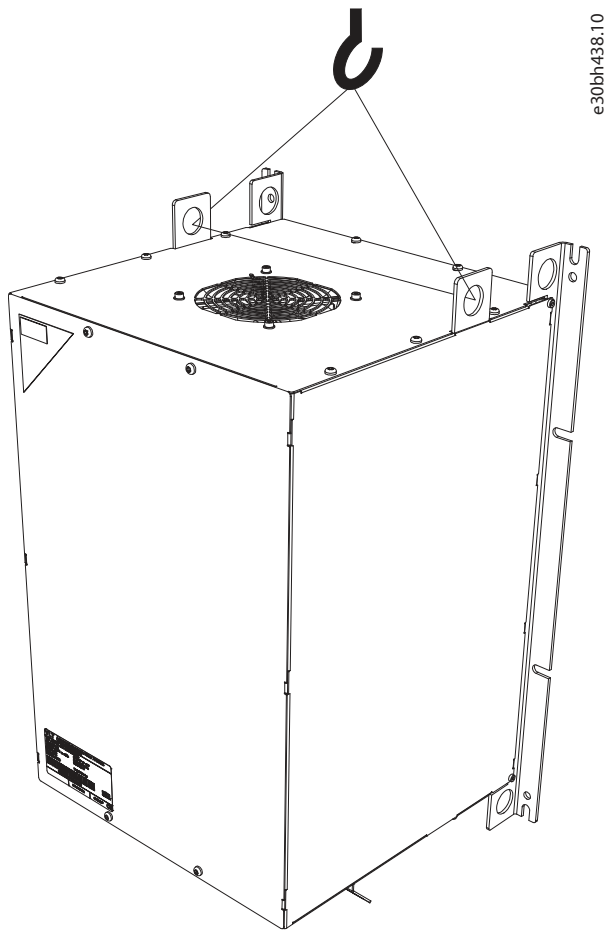

Figure 16: Lifting Method, Internal Fan Filters

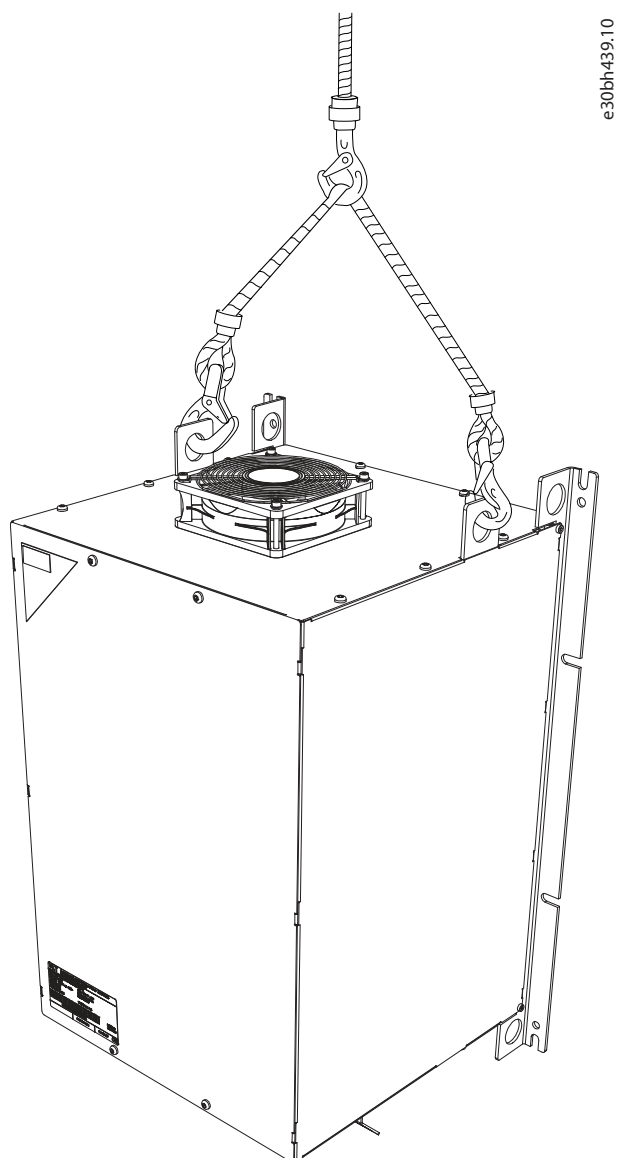

Figure 17: Recommended Lifting Method, External Fan Filters

4.1.2 Mounting Requirements

The filters are available as IP20 with optional IP21/NEMA 1 upgrade kit. During installation, follow the described recommended procedures for the protection rating.

1. Mount all filters vertically with the terminals at the bottom.
2. Pay attention to the specified mounting holes and other relevant information on the mechanical drawings in [7.4.3 IP20 Enclosures](#).
3. Do not mount the filter close to other heating elements or heat-sensitive material (such as wood).
4. Top and bottom clearances are minimum 150 mm (5.91 in).
5. The surface temperature of the IP20 filters does not exceed 70 °C (158 °F).
6. The filter can be mounted side by side with the frequency converter, and there is no spacing requirement between them.
7. These requirements also apply for the IP20 units when upgraded with the optional IP21/NEMA 1 upgrade kit.

4.1.3 Recommendations for Installation in Industrial Enclosures

To avoid high frequency noise coupling, keep a minimum distance of 150 mm (5.91 in) to:

- Motor supply wires.
- Motor wires of the drive.
- Control wires and signal wires (voltage range <48 V).

To obtain low impedance, HF connections, grounding, shielding, and other metallic connections (for example mounting plates and mounted units) should have a surface as large as possible to metallic ground. Use grounding and potential equalization wires with a cross-section as wide as possible (minimum 10 mm² (8 AWG)) or thick grounding tapes. Use copper or tinned copper shielded wires only, as steel-shielded wires are not suitable for high-frequency applications. Connect the shield with metal clamps or metal glands to the equalization bars or PE connections.

Always equip inductive switching units such as relay and magnetic contactor with varistors, RC circuits, or suppressor diodes.

4.1.4 Ventilation and Cooling Requirements

4.1.4.1 Overview of Ventilation and Cooling Requirements

The compact design of the filters is based on forced cooling, and the filters are cooled by circulating air.

Therefore, ensure that air can circulate freely above and below the filter, by observing the minimum clearance requirements. The filters are cooled via built-in variable speed fans, and they have ventilation channels in the enclosure. The fans and ventilation channels provide the required airflow to prevent the filters from overheating.

When mounting the filters in panels or other industrial enclosures, ensure that there is a sufficient airflow through the panel to reduce the risk of overheating the filter and the surrounding components.

If other heat sources (such as frequency converters) are installed in the same enclosure, also consider the heat they generate when dimensioning the cooling of the enclosure.

4.1.4.2 Requirements for IP20 and IP21/NEMA 1

To guide air through the gap between the wall and the filter, mount the filters on a wall. In installations, for example panels, where the filter is mounted on rails, the filter is not sufficiently cooled because of false airflow. To overcome the false airflow, order a backplate (thickness: 2 mm (0.08 in), shown in [Figure 19](#). See [Table 16](#) for order number.

For information about the backplate dimensions, see [7.4.5 Backplate Dimensions](#).

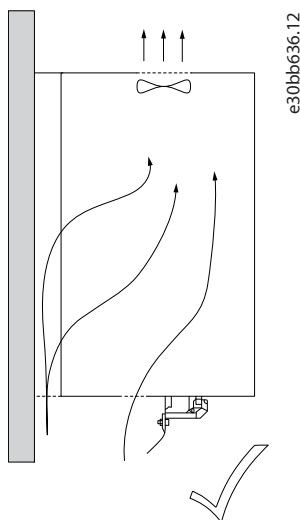

Figure 18: Correct Airflow without Backplate

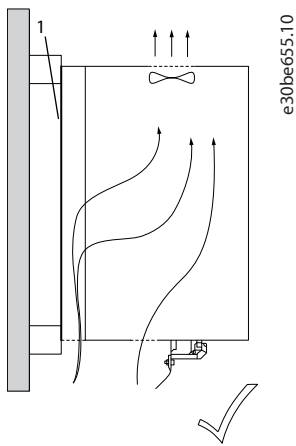

Figure 19: Correct Airflow with Backplate

- | | |
|---|-------------------------------------|
| 1 | Backplate, 2 mm (0.08 in) thickness |
|---|-------------------------------------|

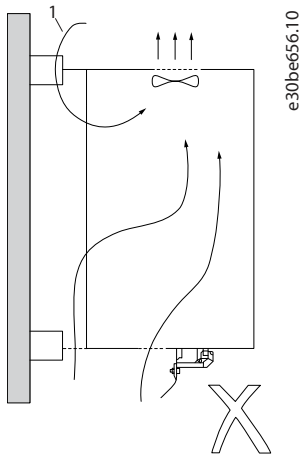

Figure 20: False Airflow

- | | |
|---|---------------|
| 1 | False airflow |
|---|---------------|

Fan concept

The AHF 005/AHF 010 use variable speed fans for cooling. The fans are supplied from mains supply and are mounted as either internal or external built-in fans. The external fans have larger dimensions. See [7.4.1 Overview of Mechanical Dimensions](#).

There are 2 different fan types, see [Figure 21](#) and [Figure 22](#):

- Internal fan: standard fan mounted inside the filter enclosure.
- External fan: standard fan mounted outside the filter enclosure.

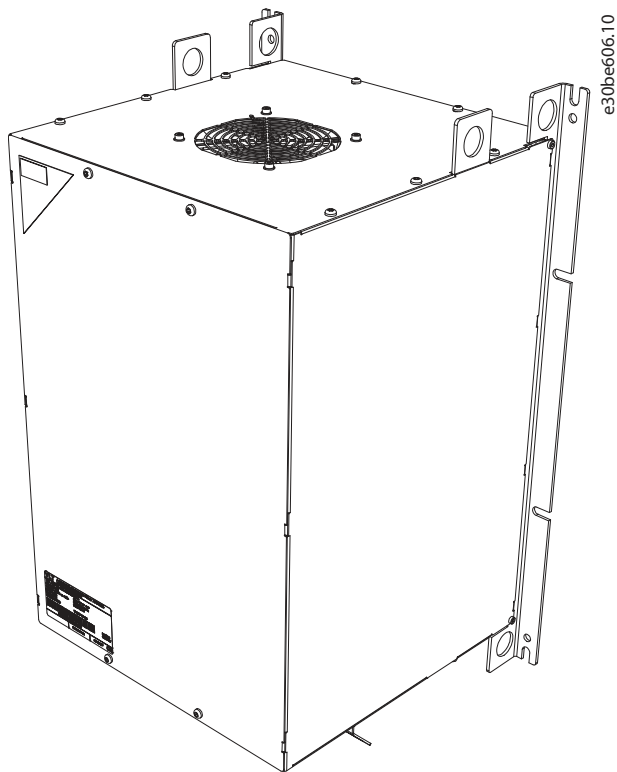

Figure 21: Fan Concept, Internal Fan

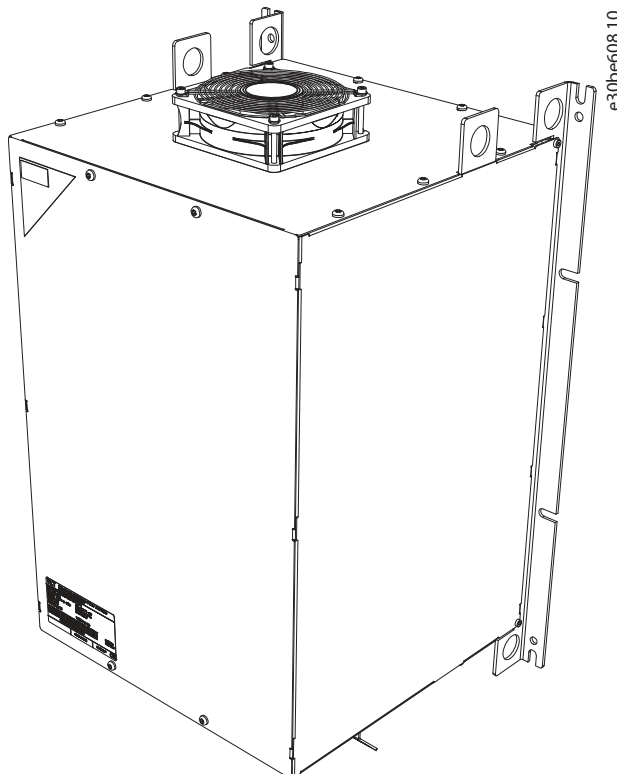

Figure 22: Fan Concept, External Fan

NOTICE

IP21/NEMA 1 UPGRADE KIT

An IP21/NEMA 1 upgrade kit is available for the VLT® Advanced Harmonic Filter AHF 005/AHF010.

- See [5.4.1.1 Overview of IP21/NEMA 1 Upgrade Kit](#) for further details.

4.2 Electrical Installation

4.2.1 Terminals

4.2.1.1 Overview of Terminals

The VLT® Advanced Harmonic Filter AHF 005/AHF 010 contains the following terminals:

- X1.1–X1.3 are the mains terminals.
- X2.1–X2.3 are the output terminals to the drive.
- X3.1–X3.3 are optional connection terminals for capacitor disconnect.
- A and B are the temperature switch connected to the drive.
- PE is for protective earth.

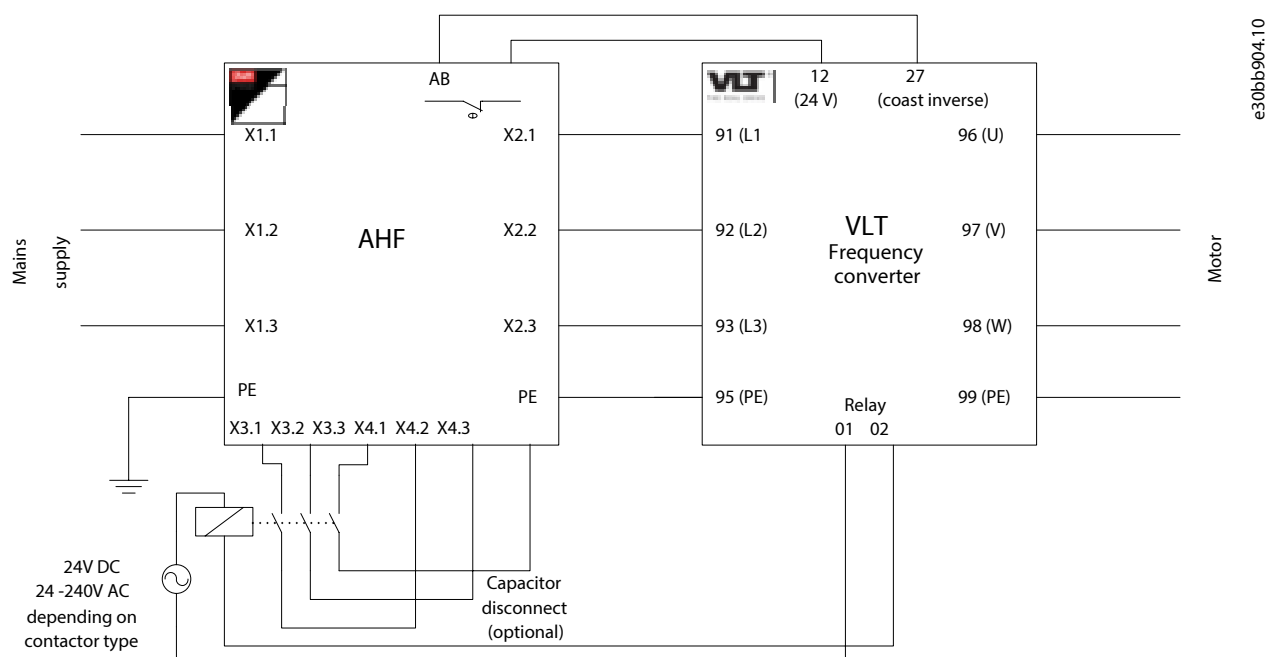

Figure 23: Connection Diagram

4.2.1.2 Terminals for Capacitor Disconnect

From the factory, the terminals for the capacitor disconnect are bypassed or looped with jumpers. When using an external contactor, remove the jumper and use a relay. Refer to the code numbers for [5.4.1.3 IP21/NEMA 1 Upgrade Kit with Built-in Capacitor Disconnect Circuitry](#), and [Figure 27](#) for more details.

NOTICE

A Danfoss frequency converter can be used for controlling the relay of an external contactor. See *chapter 6 Programming* for more information.

NOTICE

The capacitor disconnect feature does not apply to VLT® AutomationDrive FC 301.

The power factor of the VLT® Advanced Harmonic Filter AHF 005/AHF 010 decreases with decreasing load. At no load, the power factor is 0 and the capacitors produce leading current of approximately 25% of the rated filter current. In applications where reactive current is not acceptable, disconnect the capacitor bank via terminals X3.1, X3.2, X3.3 and X4.1, X4.2, and X4.3.

Per default (on delivery) the wiring shortens terminal X3.1 with X4.1, X3.2 with X4.2, and X3.3 with X4.3. If no capacitor disconnect is required, do not change these shortened terminals.

If a disconnection of the capacitors is required, place a 3-phase contactor between terminals X3 and X4. An IP21/NEMA 1 upgrade kit with built-in capacitor disconnect circuitry is available as an option, see [5.4.1.1 Overview of IP21/NEMA 1 Upgrade Kit](#).

Paralleling AHF

It is possible to run 2 filters in parallel and still use both the capacitor disconnect and the temperature switch. Wire according to [Figure 24](#).

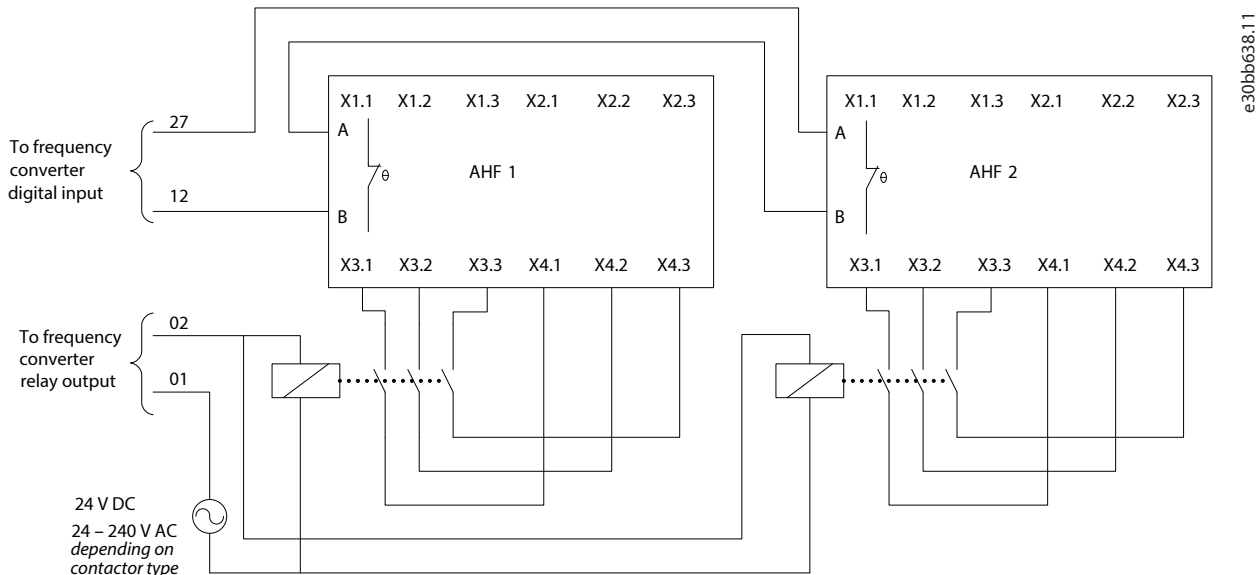

Figure 24: Parallel Use of AHF Combined with Capacitor Disconnect

NOTICE

It is not allowed to use 1 common 3-poled contactor with paralleled filters.

NOTICE

Keep the cable length between the filter and the capacitor disconnect contactor as short as possible to reduce the impedance influence on the cable. A maximum cable length of 2 m (6.6 ft) is allowed between filter and contactor.

Voltage boost

The AHF is designed to ensure the lowest possible insertion loss to provide full DC-link voltage in the drive. The target of this design is to ensure full DC-link voltage at nominal load, see B in [Figure 25](#). Providing the full DC-link voltage at nominal load results in a minor voltage boost at low-load conditions and a minor voltage drop at overload conditions. The voltage boost at low load (A in [Figure 25](#)) is approximately 5%, while the voltage drop at overload (C in [Figure 25](#)) is a few percentages. Refer to [Figure 25](#) to see the insertion loss in the drive as a function of load.

NOTICE

The voltage boost causes the voltage at the drive terminals to be up to 5% higher than the voltage at the input of the filter when the capacitors are not disconnected. Consider this situation when designing the installation. Take special care in 690 V applications where the voltage tolerance of the drive is reduced to +5%, unless a capacitor disconnect is used.

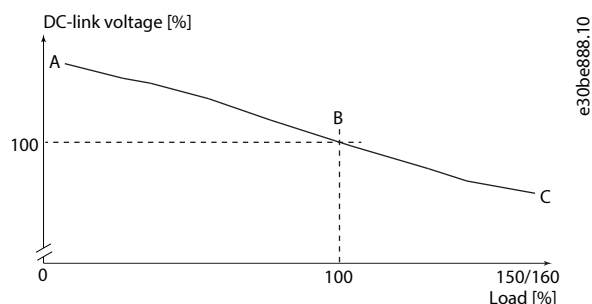

Figure 25: Insertion Loss in the Frequency Converter as a Function of Load

- | | |
|--|---|
| <p>A Low-load condition or standby. Approximately 5% voltage boost occurs without the capacitors being disconnected. If the capacitors are disconnected, the voltage boost can be reduced.</p> | <p>B Nominal load condition. The AHF is optimized for full DC-link voltage in the drive at nominal load conditions.</p> |
| <p>C Overload condition. A voltage drop of a few percentages occurs at high-overload conditions.</p> | |

NOTICE

Only switch the contactor at less than 20% output power. Allow minimum 25 s for the capacitors to discharge before reconnecting. See more details in *Chapter 6 Programming*.

NOTICE

Do not use the capacitor disconnect feature if several drives are connected to the same filter.

4.2.2 Wiring

4.2.2.1 Wiring Recommendations for Paralleling of Frequency Converters

When wiring, also refer to [Figure 23](#).

1. Connect supply voltage to terminals X1.1, X1.2, and X1.3.
2. Connect the drive supply terminals L1, L2, and L3 to the filter terminals X2.1, X2.2, and X2.3.

What to do next: If connecting several frequency converters to 1 harmonic filter, the connection method is similar to the connection described above. Connect the supply terminals L1, L2, and L3 of the frequency converters to the filter terminals X2.1, X2.2, and X2.3.

NOTICE

Use cables complying with local regulations.

4.2.2.2 Wiring Recommendations for Paralleling of Filters

If the mains input current of the frequency converter exceeds the nominal current of the largest harmonic filter, several harmonic filters can be paralleled to achieve the necessary current rating, see [7.1 General Specifications](#).

1. Connect supply voltage to terminals X1.1, X1.2, and X1.3 of the filters.

2. Connect the frequency converter supply terminals L1, L2, and L3 to the filters terminals X2.1, X2.2, and X2.3.

4.2.3 Overtemperature Protection

4.2.3.1 Overview of Overtemperature Protection

The VLT® Advanced Harmonic Filter AHF 005/AHF 010 are all equipped with a galvanically isolated switch (PELV). The switch is closed under normal operating conditions. If the filter is overheated, the switch opens.

Each filter contains 3 thermal switches mounted in series in each inductor group. At temperatures above 140 °C (284 °F), the switches open.

NOTICE

It is mandatory to use the integrated temperature switch to prevent damage of the filter caused by overtemperature. To prevent filter damage, perform an immediate stop or a controlled ramp down within maximum 30 s.

NOTICE

POSSIBLE INSUFFICIENT AIRFLOW

If the switch activates repeatedly, it is probably caused by insufficient airflow through the filter.

- Evaluate the airflow and the installation conditions.
- Check if the fan inlet or outlet is blocked.
- Check for defective fan.
- Check for defective fan control.

4.2.3.2 Programming of Digital Inputs for Overtemperature Protection

4.2.3.2.1 Example 1

The following describes the most commonly used programming examples. For more details, refer to *chapter 6 Programming*.

1. Connect terminal A of the harmonic filter to terminal 12 or 13 (voltage supply digital input, 24 V) of the frequency converter.
2. Connect terminal B to terminal 27.
3. Program the digital input terminal 27 to **Coast Inverse**.

4.2.3.2.2 Example 2

If an overtemperature is detected, the frequency converter coasts the motor and thus unloads the filter.

1. Connect terminal A of the harmonic filter to terminal 12 or 13 (voltage supply digital input, 24 V DC) of the frequency converter.
2. Connect terminal B to terminal 33.
3. Set parameter **1-90 Motor Thermal Protection**.
4. Set parameter **1-93 Thermistor Resource**.

NOTICE

The maximum rating of the temperature switch is 250 V AC and 2 A.

5 Selection of Advanced Harmonic Filter

5.1 Overview of Selection of Advanced Harmonic Filter

This chapter helps to select the right filter size and contains calculation examples, electrical data, and order number for the filters.

5.2 Selecting the Correct AHF

5.2.1 Overview of Selecting the Correct AHF

For optimal performance, size the VLT® Advanced Harmonic Filter AHF 005/AHF 010 for the mains input current to the frequency converter. This current is the input current drawn based on the expected load of the frequency converter and not on the size of the frequency converter itself.

5.2.2 Calculation of Correct Filter Size

Calculate the mains input current of the drive ($I_{FC,L}$). Use the nominal motor current ($I_{M,N}$) and the displacement factor ($\cos \phi$) of the motor for the calculation. Both values are normally printed on the nameplate of the motor. If the nominal motor voltage ($U_{M,N}$) is unequal to the actual mains voltage (U_L), correct the calculated current with the ratio between these voltages, see the following formula:

$$I_{FC,L} = 1.1 \times I_{M,N} \times \cos(\phi) \times \frac{U_{M,N}}{U_L}$$

The selected VLT® Advanced Harmonic Filter AHF 005/AHF 010 must have a nominal current ($I_{AHF,N}$) \geq the calculated drive mains input current ($I_{FC,L}$).

NOTICE

Do not oversize the AHF. The best harmonic performance is obtained at nominal filter load. Using an oversized filter most likely results in reduced THDi performance.

If connecting several drives to the same filter, size the AHF according to the sum of the calculated mains input currents.

NOTICE

If the AHF is sized for a specific load, and the motor is changed, recalculate the current to avoid overloading the AHF.

5.2.3 Calculation Example

Table 6: Data for Calculation of Filter Size

Data	Value
System mains voltage (U_L)	380 V
Motor nameplate power (P_M)	55 kW (75 hp)
Motor efficiency (η_M)	0.96
Drive efficiency (η_{FC})	0.97
AHF efficiency (η_{AHF}) (worst-case estimate)	0.98

Maximum line current (RMS):

$$\frac{P_M \times 1000}{U_L \times \eta_{FC} \times \eta_{AHF} \times \sqrt{3}} = \frac{55 \times 1000}{380 \times 0.96 \times 0.97 \times 0.98 \times \sqrt{3}} = 91.57A$$

5.2.4 Voltage Boost

NOTICE

VOLTAGE BOOST

The voltage boost causes the voltage at the frequency converter terminals to be up to 5% higher than the voltage at the input of the filter when the capacitors are not disconnected. Consider this situation when designing the installation. Take special care in 690 V applications where the voltage tolerance of the frequency converter is reduced to +5%, unless a capacitor disconnect is used.

- For more information, see [4.2.1.2 Terminals for Capacitor Disconnect](#) and [Figure 25](#).

5.3 Selection Tables

5.3.1 Selection Tables terminology

[Table 7](#) explains in detail the terminology used in [Table 8](#) to [Table 12](#).

Table 7: Terminology Used in the Selection Tables

Terms	Description
Power rating	The power rating of the drive. The power rating is not necessarily the type code power rating, but the actual operating power rating. Changing operation conditions between HO and NO, changes the drive operating conditions. The selection of the VLT® Advanced Harmonic Filter AHF 005/AHF 010 must reflect the actual operating conditions of the drive.
Input current	The maximum input current ratings of the drive in the specific mains supply voltage range.
Current rating	Filter current rating at nominal load. Current ratings are combined values when paralleling filters.
AHF 005	AHF version with a performance of 5% THDi or better at a system level with nominal load.
AHF 010	AHF version with a performance level of 10% THDi or better at a system level with nominal load.
Code number	AHF code number. The selected AHF must match the actual mains type.
Enclosure size, enclosure protection ratings, and fan concept:	Confirming the fan concepts and reference to mechanical drawings as: <ul style="list-style-type: none"> • [Enclosure size] IP20 AHF version 3 with internal fan with variable speed. • [Enclosure size] IP20 AHF version 3 with external fan with variable speed.
IP20	Enclosure protection degree IP20. IP21/NEMA 1 upgrade kits are available for all IP20 filters as separate options.

Table 8: Frequency Converters with Voltage Classes T4 and T5, Operating at 380–415 V, 50 Hz

Drive values		AHF values				
Power rating [kW] ⁽¹⁾	Input current 380–440 V [A]	Current rating [A]	Code numbers ⁽²⁾		Enclosure type	
			AHF 005 IP20	AHF 010 IP20	AHF 005 IP20	AHF 010 IP20
0.37	1.2	10	130B1229	130B1027	X1-V3 IP20 if	X1-V3 IP20 if
0.55	1.6					
0.75	2.2					
1.1	2.7					
1.5	3.7					
2.2	5.0					
3.0	6.5					
4.0	9.0	14	130B1229	130B1027	X1-V3 IP20 if	X1-V3 IP20 if
5.5	11.7					
7.5	14.4	22	130B1231	130B1058	X1-V3 IP20 ef	X1-V3 IP20 ef
11	22		130B1232	130B1059	X2-V3 IP20 ef	X2-V3 IP20 if
15	29	29	130B1233	130B1089	X2-V3 IP20 ef	X2-V3 IP20 if
18.5	34	34	130B1238	130B1094	X3-V3 IP20 if	X3-V3 IP20 if
22	40	40	130B1239	130B1111	X3-V3 IP20 if	X3-V3 IP20 if
30	55	55	130B1240	130B1176	X3-V3 IP20 if	X3-V3 IP20 if
37	66	66	130B1241	130B1180	X4-V3 IP20 if	X4-V3 IP20 if
45	82	82	130B1247	130B1201	X4-V3 IP20 ef	X4-V3 IP20 ef
55	96	96	130B1248	130B1204	X5-V3 IP20 ef	X5-V3 IP20 ef
75	133	133	130B1249	130B1207	X5-V3 IP20 ef	X5-V3 IP20 ef
90	171	171	130B1250	130B1213	X6-V3 IP20 ef	X6-V3 IP20 if
110	204	204	130B1251	130B1214	X6-V3 IP20 ef	X6-V3 IP20 if
132	251	251	130B1258	130B1215	X7-V3 IP20 if	X7-V3 IP20 if
160	304	304	130B1259	130B1216	X7-V3 IP20 if	X7-V3 IP20 if
–	–	325	130B3152 ⁽³⁾	130B3136 ⁽³⁾	X8-V3 IP20 if	X7-V3 IP20 if
200	381	381	130B1260	130B1217	X8-V3 IP20 ef	X7-V3 IP20 if
250	463	480	130B1261	130B1228	X8-V3 IP20 ef	X8-V3 IP20 ef
315	590	608	2 x 130B1259	2 x 130B1216	See individual filters	
355	647	650	2 x 130B3152	2 x 130B3136		
400	684	685	130B1259 + 130B1260	130B1216 + 130B1217		
450	779	762	2 x 130B1260	2 x 130B1217		
500	857	861	130B1260 + 130B1261	130B1217 + 130B1228		
560	964	960	2 x 130B1261	2 x 130B1228		
630	1090	1140	3 x 130B1260	3 x 130B1217		

Table 8: Frequency Converters with Voltage Classes T4 and T5, Operating at 380–415 V, 50 Hz - (continued)

Drive values		AHF values				
Power rating [kW] ⁽¹⁾	Input current 380–440 V [A]	Current rating [A]	Code numbers ⁽²⁾		Enclosure type	
			AHF 005 IP20	AHF 010 IP20	AHF 005 IP20	AHF 010 IP20
710	1227	1240	2 x 130B1260 + 130B1261	2 x 130B1217 + 130B1228		
800	1422	1440	3 x 130B1261	3 x 130B1228		
1000	1675	1720	2 x 130B1260 + 2 x 130B1261	2 x 130B1217 + 2 x 130B1228		

1) The power rating in the selection table is the actual operating power and not necessarily the type code power rating. Changing operating conditions between HO and NO changes the actual operating conditions and the filter selection must reflect actual operating conditions.

2) The fan control system allows extended input voltage range as 200–415 V. The AHFs for 380–415 V/50 Hz mains operation can be operated with 200–240 V mains supply.

3) Filters are used as paralleling for 355 kW drive.

Table 9: Frequency Converters with Voltage Classes T4 and T5, Operating at 380–415 V, 60 Hz

Drive values		AHF values				
Power rating [kW] ⁽¹⁾	Input current 380–440V [A]	Current rating [A]	Code numbers ⁽²⁾		Enclosure type	
			AHF 005 IP20	AHF 010 IP20	AHF 005 IP20	AHF 010 IP20
0.37	1.2	10	130B2857	130B2262	X1-V3 IP20 if	X1-V3 IP20 if
0.55	1.6					
0.75	2.2					
1.1	2.7					
1.5	3.7					
2.2	5.0					
3.0	6.5					
4.0	9.0	14	130B2858	130B2265	X1-V3 IP20 ef	X1-V3 IP20 ef
5.5	11.7					
7.5	14.4	22	130B2859	130B2268	X2-V3 IP20 ef	X2-V3 IP20 if
11	22					
15	29					
18.5	34					
22	40					
30	55					
37	66					
45	82					
55	96					
75	133					
90	171					
110	204					
132	251					
		251	130B2870	130B2700	X7-V3 IP20 if	X7-V3 IP20 if

Table 9: Frequency Converters with Voltage Classes T4 and T5, Operating at 380–415 V, 60 Hz - (continued)

Drive values		AHF values				
Power rating [kW] ⁽¹⁾	Input current 380-440V [A]	Current rating [A]	Code numbers ⁽²⁾		Enclosure type	
			AHF 005 IP20	AHF 010 IP20	AHF 005 IP20	AHF 010 IP20
160	304	304	130B2871	130B2819	X8-V3 IP20 if	X7-V3 IP20 if
–	–	325	130B3156 ⁽³⁾	130B3154 ⁽³⁾	X8-V3 IP20 ef	X7-V3 IP20 ef
200	381	381	130B2872	130B2855	X8-V3 IP20 ef	X7-V3 IP20 ef
250	463	480	130B2873	130B2856	X8-V3 IP20 ef	X8-V3 IP20 ef
315	590	608	2 x 130B2871	2 x 130B2819	See individual filters	
355	647	650	2 x 130B3156	2 x 130B3154		
400	684	685	130B2871 + 130B2872	130B2819 + 130B2855		
450	779	762	2 x 130B2872	2 x 130B2855		
500	857	861	130B2872 + 130B2873	130B2855 + 130B2856		
560	964	960	2 x 130B2873	2 x 130B2856		
630	1090	1140	3 x 130B2872	3 x 130B2855		
710	1227	1240	2 x 130B2872 + 130B2873	2 x 130B2855 + 130B2856		
800	1422	1440	3 x 130B2873	3 x 130B2856		
1000	1675	1720	2 x 130B2872 + 2 x 130B2873	2 x 130B2855 + 2 x 130B2856		

1) The power ratings in selection table are the actual operating power and not necessarily the type code power rating. Changing operating conditions between HO and NO changes the actual operating conditions and the filter selection must reflect actual operating conditions.

2) The fan control system allows extended input voltage range as 200–415 V. The AHFs for 380–415 V/60 Hz mains operation can be operated with 200–240 V mains supply.

3) Filters are used as paralleling for 355 kW drive.

Table 10: Frequency Converters with Voltage Classes T4 and T5, Operating at 440–480 V, 60 Hz

Drive values			AHF values					
Power rating		Input current 441-500V [A]	Current rating [A]		Code numbers		Enclosure type	
[kW] ⁽¹⁾	[HP] ⁽²⁾		AHF 005	AHF 010	AHF 005 IP20	AHF 010 IP20	AHF 005 IP20	AHF 010 IP20
0.37	0.50	1.0	10	10	130B1752	130B1482	X1-V3 IP20 if	X1-V3 IP20 if
0.55	0.75	1.4						
0.75	1.0	1.9						
1.1	1.5	2.7						
1.5	2.0	3.1						
2.2	3.0	4.3						
3.0	4.0	5.7						
4.0	5.5	7.4						

Table 10: Frequency Converters with Voltage Classes T4 and T5, Operating at 440–480 V, 60 Hz - (continued)

Drive values			AHF values					
Power rating		Input current 441-500V	Current rating [A]		Code numbers		Enclosure type	
[kW] ⁽¹⁾	[HP] ⁽²⁾	[A]	AHF 005	AHF 010	AHF 005 IP20	AHF 010 IP20	AHF 005 IP20	AHF 010 IP20
5.5	7.5	9.9	14	14	130B1753	130B1483	X1-V3 IP20 ef	X1-V3 IP20 ef
7.5	10	13						
11	15	19	19	19	130B1754	130B1484	X2-V3 IP20 ef	X2-V3 IP20 if
15	20	25	25	25	130B1755	130B1485	X2-V3 IP20 ef	X2-V3 IP20 if
18.5	25	31	31	31	130B1756	130B1486	X3-V3 IP20 if	X3-V3 IP20 if
22	30	36	36	36	130B1757	130B1487	X3-V3 IP20 if	X3-V3 IP20 if
30	40	47	48	48	130B1758	130B1488	X3-V3 IP20 if	X3-V3 IP20 if
37	50	59	60	60	130B1759	130B1491	X4-V3 IP20 if	X4-V3 IP20 if
45	60	73	73	73	130B1760	130B1492	X4-V3 IP20 ef	X4-V3 IP20 ef
55	75	95	95	95	130B1761	130B1493	X5-V3 IP20 ef	X5-V3 IP20 ef
75	100	118	118	118	130B1762	130B1494	X5-V3 IP20 ef	X5-V3 IP20 ef
90	125	154	154	154	130B1763	130B1495	X6-V3 IP20 ef	X6-V3 IP20 if
110	150	183	183	183	130B1764	130B1496	X6-V3 IP20 ef	X6-V3 IP20 if
132	200	231	231	231	130B1765	130B1497	X7-V3 IP20 if	X7-V3 IP20 if
160	250	291	291	291	130B1766	130B1498	X8-V3 IP20 if	X7-V3 IP20 if
200	300	348	355	355	130B1768	130B1499	X8-V3 IP20 ef	X7-V3 IP20 ef
–	–	–	380	380	130B3167 ⁽³⁾	130B3165 ⁽³⁾	X8-V3 IP20 ef	X7-V3 IP20 ef
250	350	427	436	436	130B1769	130B1751	X8-V3 IP20 ef	X8-V3 IP20 ef

Table 10: Frequency Converters with Voltage Classes T4 and T5, Operating at 440–480 V, 60 Hz - (continued)

Drive values			AHF values					
Power rating		Input current 441-500V	Current rating [A]		Code numbers		Enclosure type	
[kW] ⁽¹⁾	[HP] ⁽²⁾	[A]	AHF 005	AHF 010	AHF 005 IP20	AHF 010 IP20	AHF 005 IP20	AHF 010 IP20
315	450	531	522	522	130B1765 + 130B1766	130B1497 + 130B1498	See individual filters	
355	500	580	582	582	2 x 130B1766	2 x 130B1498		
400	550	667	671	671	130B1766 + 130B3167	130B1498 + 130B3165		
450	600	771	710	710	2 x 130B1768	2 x 130B1499		
500	650	759	760	760	2 x 130B3167	2 x 130B3165		
560	750	867	872	872	2 x 130B1769	2 x 130B1751		
630	900	1022	1065	1065	3 x 130B1768	3 x 130B1499		
710	1000	1129	1140	1140	3 x 130B3167	3 x 130B3165		
800	1200	1344	1308	1308	3 x 130B1769	3 x 130B1751		
1000	1350	1490	1582	1582	2 x 130B1768 + 2 x 130B1769	2 x 130B1499 + 2 x 130B1751		

1) The power ratings in selection table are the actual operating power and not necessarily the type code power rating. Changing operating conditions between HO and NO changes the actual operating conditions and the filter selection must reflect actual operating conditions.

2) Typical HP shaft output at 460 V.

3) Filters are used as paralleling for 500 kW and 710 kW.

Table 11: Frequency Converters with Voltage Classes T6 and T7, Operating at 600 V, 60 Hz

Drive values			AHF values							
Power rating			Input current [A]		Current rating at 600 V		Code numbers		Enclosure type	
[kW] ⁽¹⁾	T6 [HP] ⁽²⁾	T7 [HP] ⁽²⁾	T6 551– 600 V	T7 551– 600 V	AHF 005 [A]	AHF 010 [A]	AHF 005 IP20	AHF 010 IP20	AHF 005 IP20	AHF 010 IP20
11	15	10	16	15	15	15	130B5246	130B5212	X3-V3 IP20 if	X3-V3 IP20 if
15	20	15	20	19,5	20	20	130B5247	130B5213	X3-V3 IP20 if	X3-V3 IP20 if

Table 11: Frequency Converters with Voltage Classes T6 and T7, Operating at 600 V, 60 Hz - (continued)

Drive values					AHF values					
Power rating			Input current [A]		Current rating at 600 V		Code numbers		Enclosure type	
[kW] ⁽¹⁾	T6 [HP] ⁽²⁾	T7 [HP] ⁽²⁾	T6 551–600 V	T7 551–600 V	AHF 005 [A]	AHF 010 [A]	AHF 005 IP20	AHF 010 IP20	AHF 005 IP20	AHF 010 IP20
18,5	25	20	24	24	24	24	130B5248	130B5214	X3-V3 IP20 ef	X3-V3 IP20 ef
22	30	25	31	29	29	29	130B5249	130B5215	X4-V3 IP20 ef	X4-V3 IP20 ef
30	40	30	37	36	36	36	130B5250	130B5216	X4-V3 IP20 ef	X4-V3 IP20 ef
37	50	40	47	49	50	50	130B5251	130B5217	X5-V3 IP20 ef	X5-V3 IP20 ef
45	60	50	56	59	58	58	130B5252	130B5218	X5-V3 IP20 ef	X5-V3 IP20 ef
55	75	60	75	74	77	77	130B5253	130B5219	X6-V3 IP20 ef	X6-V3 IP20 ef
75	100	75	91	85	87	87	130B5254	130B5220	X6-V3 IP20 ef	X6-V3 IP20 ef
90	125	100	119	106	109	109	130B5255	130B5221	X6-V3 IP20 ef	X6-V3 IP20 ef
110	–	125	–	124	128	128	130B5256	130B5222	X6-V3 IP20 ef	X6-V3 IP20 ef
132	–	150	–	151	155	155	130B5257	130B5223	X7-V3 IP20 ef	X7-V3 IP20 ef
160	–	200	–	189	197	197	130B5258	130B5224	X7-V3 IP20 ef	X7-V3 IP20 ef
200	–	250	–	234	240	240	130B5259	130B5225	X8-V3 IP20 ef	X7-V3 IP20 ef
250	–	300	–	286	296	296	130B5260	130B5226	X8-V3 IP20 ef	X8-V3 IP20 ef
315	–	350	–	339	394	366	2 x 130B5258	130B5227		X8-V3 IP20 ef
355	–	400	–	366	394	366	2 x 130B5258	130B5227		X8-V3 IP20 ef
400	–	400	–	395	394	395	2 x 130B5258	130B5228		X8-V3 IP20 ef

Table 11: Frequency Converters with Voltage Classes T6 and T7, Operating at 600 V, 60 Hz - (continued)

Drive values				AHF values						
Power rating			Input current [A]		Current rating at 600 V		Code numbers		Enclosure type	
[kW] ⁽¹⁾	T6 [HP] ⁽²⁾	T7 [HP] ⁽²⁾	T6 551–600 V	T7 551–600 V	AHF 005 [A]	AHF 010 [A]	AHF 005 IP20	AHF 010 IP20	AHF 005 IP20	AHF 010 IP20
500	–	500	–	482	480	480	2 x 130B5259	2 x 130B5225	See individual filters	
560	–	550	–	549	592	592	2 x 130B5260	2 x 130B5226		
630	–	650	–	613	720	732	3 x 130B5259	2 x 130B5227		
710	–	750	–	711	720	732	3 x 130B5259	2 x 130B5227		
800	–	950	–	828	888	888	3 x 130B5260	3 x 139B5226		
900	–	1050	–	920	960	960	4 x 130B5259	3 x 130B5227		
1000	–	1150	–	1032	1184	1098	4 x 130B5260	3 x 130B5227		

1) The power ratings in selection table are the actual operating power and not necessarily the type code power rating. Changing operating conditions between HO and NO changes the actual operating conditions and the filter selection must reflect actual operating conditions.

2) Typical HP shaft output at 575 V.



NOTE: In 690 V applications, only filters of identical size shall be configured in parallel.

Table 12: Frequency Converters with Voltage Classes T6 and T7, Operating at 500–690 V, 50 Hz

Drive values				AHF values					
Power rating	Input current [A]			Current rating at 690 V		Code numbers		Enclosure type	
[kW] ⁽¹⁾	T6 525–550 V	T7 525–550 V	T7 690 V	AHF 005 [A]	AHF 010 [A]	AHF 005 IP20	AHF 010 IP20	AHF 005 IP20	AHF 010 IP20
11	17.2	15.0	14.5	15	15	130B5088	130B5280	X3-V3 IP20 if	X3-V3 IP20 if
15	20.9	19.5	19.5	20	20	130B5089	130B5281	X3-V3 IP20 if	X3-V3 IP20 if
18.5	25.4	24	24	24	24	130B5090	130B5282	X3-V3 IP20 ef	X3-V3 IP20 ef
22	32.7	29	29	29	29	130B5092	130B5283	X4-V3 IP20 ef	X4-V3 IP20 ef
30	39	36	36	36	36	130B5125	130B5284	X4-V3 IP20 ef	X4-V3 IP20 ef
37	49	49	48	50	50	130B5144	130B5285	X5-V3 IP20 ef	X5-V3 IP20 ef

Table 12: Frequency Converters with Voltage Classes T6 and T7, Operating at 500–690 V, 50 Hz - (continued)

Drive values				AHF values					
Power rating	Input current [A]			Current rating at 690 V		Code numbers		Enclosure type	
[kW] ⁽¹⁾	T6 525–550 V	T7 525–550 V	T7 690 V	AHF 005 [A]	AHF 010 [A]	AHF 005 IP20	AHF 010 IP20	AHF 005 IP20	AHF 010 IP20
45	59	59	58	58	58	130B5168	130B5286	X5-V3 IP20 ef	X5-V3 IP20 ef
55	78.9	77	77	77	77	130B5169	130B5287	X6-V3 IP20 ef	X6-V3 IP20 ef
75	95.3	89	87	87	87	130B5170	130B5288	X6-V3 IP20 ef	X6-V3 IP20 ef
90	124.3	110	109	109	109	130B5172	130B5289	X6-V3 IP20 ef	X6-V3 IP20 ef
110	–	130	128	128	128	130B5195	130B5290	X6-V3 IP20 ef	X6-V3 IP20 ef
132	–	158	155	155	155	130B5196	130B5291	X7-V3 IP20 ef	X7-V3 IP20 ef
160	–	198	197	197	197	130B5197	130B5292	X7-V3 IP20 ef	X7-V3 IP20 ef
200	–	245	240	240	240	130B5198	130B5293	X8-V3 IP20 ef	X7-V3 IP20 ef
250	–	299	296	296	296	130B5199	130B5294	X8-V3 IP20 ef	X8-V3 IP20 ef
315	–	355	352	394	366	2 x 130B5197	130B5295		X8-V3 IP20 ef
355	–	381	366	394	395	2 x 130B5197	130B5296		X8-V3 IP20 ef
400	–	413	400	480	480	2 x 130B5098	2x 130B5293	See individual filters	
500	–	504	482	592	592	2 x 130B5199	2 x 130B5294		
560	–	574	549	592	592	2 x 130B5199	2 x 130B5294		
630	–	642	613	720	732	3 x 130B5198	2 x 130B5295		
710	–	743	711	788	732	4 x 130B5197	2 x 130B5295		
800	–	866	828	888	888	3 x 130B5199	3 x 130B5294		
900	–	962	920	960	1098	4 x 130B5198	3 x 130B5295		

1) The power ratings in selection table are the actual operating power and not necessarily the type code power rating. Changing operating conditions between HO and NO changes the actual operating conditions and the filter selection must reflect actual operating conditions.

5.3.2 Non-Danfoss Contactors

Non-Danfoss contactors are compatible with the VLT® Advanced Harmonic Filter AHF 005/AHF 010. If using non-Danfoss contactors for capacitor disconnect, always select AC3-types. The current rating of the contactor must be equal to or higher than 50% of the nominal current rating of the AHF.

If the contactor is controlled by external equipment and not by a specific parameter in a Danfoss frequency converter, use contactors for capacitive switching soft-charging capacitors.

Soft charge contactors must also be used in 690V applications to ensure protection of the Drive.

5.4 Accessories

5.4.1 IP21/NEMA 1 Upgrade Kit

5.4.1.1 Overview of IP21/NEMA 1 Upgrade Kit

An upgrade kit is available for upgrading the VLT® Advanced Harmonic Filter AHF 005/AHF 010 from IP21 to IP21/NEMA 1.

The kit consists of 2 parts:

- A top plate that prevents dirt and vertically falling drops of water from entering the filter.
- A terminal box enclosing the terminals and connections, thus ensuring touch-safe terminals.

[Figure 26](#) shows the upgrade kit mounted on a filter with external fan. However, the kit is used for filters with both internal and external fan, and does not vary according to fan type.

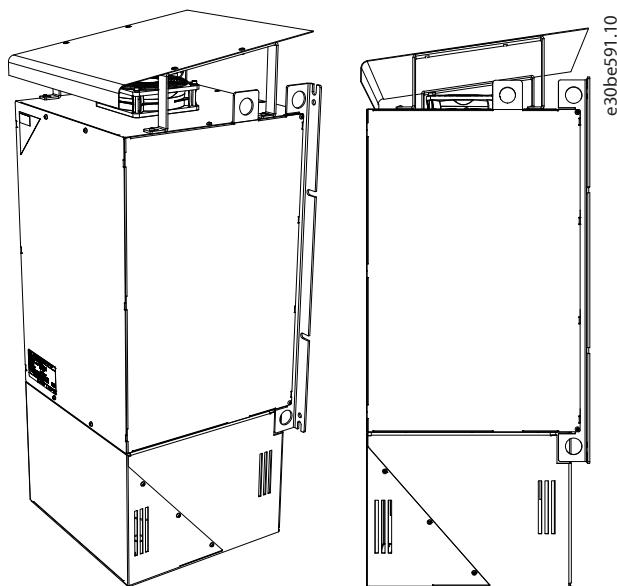

Figure 26: IP21/NEMA 1 Kit, Internal Fan and External Fan

Furthermore, the kit is available in 2 versions:

- Without built-in capacitor disconnect circuitry.
- With built-in capacitor disconnect circuitry.

For further information on capacitor disconnect circuitry, refer to [4.2.1.2 Terminals for Capacitor Disconnect](#).

5.4.1.2 IP21/NEMA 1 Upgrade Kit without Built-in Capacitor Disconnect Circuitry

The upgrade kits are supporting the VLT® Advanced Harmonic Filters family types AHF 005/AHF 010, IP20 revision 03.

NOTICE											
The IP21/NEMA 1 upgrade kits can only be used in combination with AHF revision 3. Contact Danfoss for IP21/NEMA 1 upgrade kits for AHF revision 1 or 2. Refer to <i>chapter 8 Spare Parts</i> for more information on identification of revision number.											

Table 13: Selection Table, Upgrade Kit without Built-in Capacitor Disconnect Circuitry

Valid only for AHF revision 03										AHF enclosure type	IP21/NEMA 1 Kit without capacitor disconnect circuitry	
380–415 V 50 Hz		380–415 V 60 Hz		440–480 V 60 Hz		600 V 60 Hz		500– 690 V 50 Hz				
AHF 005 [A]	AHF 010 [A]	AHF 005 [A]	AHF 010 [A]	AHF 005 [A]	AHF 010 [A]	AHF 005 [A]	AHF 010 [A]	AHF 005 [A]	AHF 010 [A]		Description	Code number
10	10	10	10	10	10	–	–	–	–	X1-V3 IP20 if X1-V3 IP20 ef	IP21/NEMA 1 Kit for AHF3 X1	175U3274
22	22	22	22	19	19	–	–	–	–	X2-V3 IP20 if X2-V3 IP20 ef	IP21/NEMA1 Kit for AHF3 X2	175U3275
34	34	34	34	31	31	15	15	15	15	X3-V3 IP20 if X3-V3 IP20 ef	IP21/NEMA1 Kit for AHF3 X3	175U3276
40	40	40	40	36	36	20	20	20	20			
55	55	55	55	48	48	24	24	24	24			
66	66	66	66	60	60	29	29	29	29	X4-V3 IP20 if X4-V3 IP20 ef	IP21/NEMA1 Kit for AHF3 X4	175U3277
82	82	82	82	73	73	36	36	36	36			
96	96	96	96	95	95	50	50	50	50	X5-V3 IP20 if X5-V3 IP20 ef	IP 21/NEMA1 Kit for AHF3 X5	175U3278
133	133	133	133	118	118	58	58	58	58			
171	171	171	171	154	154	77	77	77	77	X6-V3 IP20 if X6-V3 IP20 ef	IP21/NEMA1 Kit for AHF3 X6	175U3279
204	204	204	204	183	183	87	87	87	87			
						109	109	109	109			
						128	128	128	128			
251	251	251	251	231	231	155	155	155	155	X7-V3 IP20 if X7-V3 IP20 ef	IP21/NEMA1 Kit for AHF3 X7	175U3281
304	304		304		291	197	197	197	197			
	325		325		355		240		240			
	381		381		380							
325	480	304	480	291	436	240	296	240	296	X8-V3 IP20 if X8-V3 IP20 ef	IP21/NEMA1 Kit for AHF3 X8	175U3282
381		325		355		296	366	296	366			
480		381		380			395		395			
		480		436								

5.4.1.3 IP21/NEMA 1 Upgrade Kit with Built-in Capacitor Disconnect Circuitry

NOTICE											
The IP21/NEMA 1 upgrade kits can only be used in combination with AHF revision 3. Contact Danfoss for IP21/NEMA 1 upgrade kits for AHF revision 1 or 2. Refer to <i>chapter 8 Spare Parts</i> for more information on identification of revision number.											

Table 14: Selection Table, Upgrade Kit with Built-in Capacitor Disconnect Circuitry

Valid only for AHF revision 03												
AHF type										AHF enclosure type	IP21/NEMA 1 Kit without capacitor disconnect circuitry	
380–415 V 50 Hz		380–415 V 60 Hz		440–480 V 60 Hz		600 V 60 Hz		500– 690 V 50 Hz			Description	Code number
AHF 005 [A]	AHF 010 [A]	AHF 005 [A]	AHF 010 [A]	AHF 005 [A]	AHF 010 [A]	AHF 005 [A]	AHF 010 [A]	AHF 005 [A]	AHF 010 [A]			
10	10	10	10	10	10	–	–	–	–	X1-V3 IP20 if X1-V3 IP20 ef	IP21/NEMA 1 Kit for AHF3 X1 and con- tactor	175U5903
14	14	14	14	14	14							
22	22	22	22	19	19	–	–	–	–	X2-V3 IP20 if X2-V3 IP20 ef	IP21/NEMA1 Kit for AHF3 X2 and con- tactor	175U5904
29	29	29	29	25	25							
34	34	34	34	31	31	15	15	15	15	X3-V3 IP20 if X3-V3 IP20 ef	IP21/NEMA1 Kit for AHF3 X3 and con- tactor	175U5905
40	40	40	40	36	36	20	20	20	20			
55	55	55	55	48	48	24	24	24	24			
66	66	66	66	60	60	29	29	29	29	X4-V3 IP20 if X4-V3 IP20 ef	IP21/NEMA1 Kit for AHF3 X4 and con- tactor	175U5906
82	82	82	82	73	73	36	36	36	36			
96	96	96	96	95	95	50	50	50	50	X5-V3 IP20 if X5-V3 IP20 ef	IP 21/NEMA1 Kit for AHF3 X5 and con- tactor	175U5907
133	133	133	133	118	118	58	58	58	58			
171	171	171	171	154	154	77	77	77	77	X6-V3 IP20 if X6-V3 IP20 ef	IP21/NEMA1 Kit for AHF3 X6 and con- tactor	175U5908
204	204	204	204	183	183	87	87	87	87			
						109	109	109	109			
						128	128	128	128			
251	251	251	251	231	231	155	155	155	155	X7-V3 IP20 if X7-V3 IP20 ef	IP21/NEMA1 Kit for AHF3 X7 and con- tactor	175U5909
304	304		304		291	197	197	197	197			
	325		325		355		240		240			
	381		381		380							
325	–	304	–	291	–	240	296	240	240	X8-V3 IP20 if X8-V3 IP20 ef	IP21/NEMA1 Kit for AHF3 X8 and con- tactor	175U6100
381		325		355		296	366	296	296			
		381		380								
480	480	480	480	436	436	–	395	–	395	X8-V3 IP20 if X8-V3 IP20 ef	IP21/NEMA1 Kit for AHF3 X8 and con- tactor	175U6100

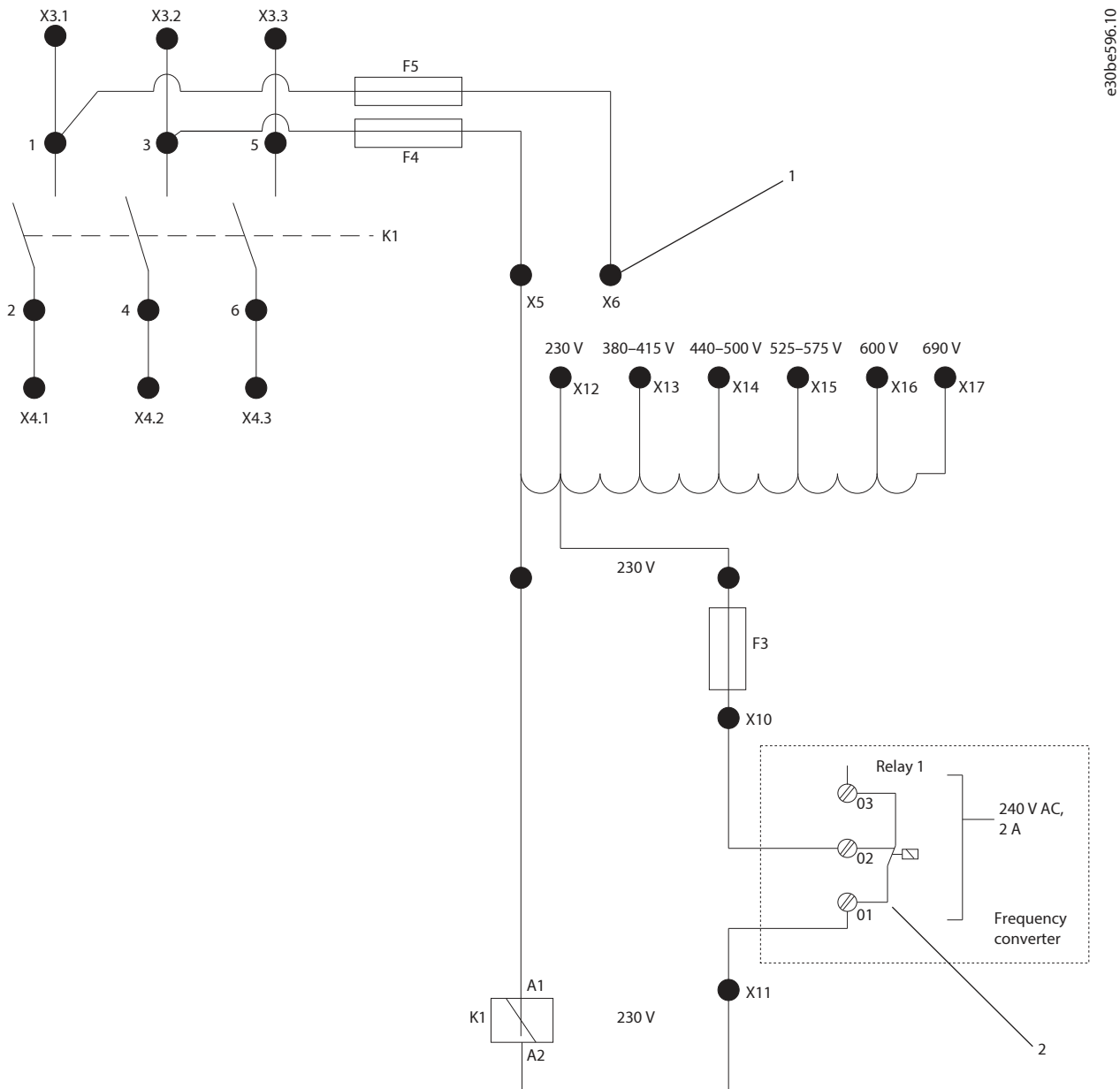

e30be596.10

Figure 27: Control Voltage Setting

- | | |
|--|--|
| <p>1 The jumper connection wire is delivered looped at terminal X6 from the factory. Refer to Table 15 for selecting the correct terminal for jumper connection.</p> | <p>2 Relay on the control card of the drive.</p> |
|--|--|

For more details on wiring of capacitor disconnect, refer to [4.2.1.2 Terminals for Capacitor Disconnect](#).

Table 15: Control Voltage Setting, IP21/NEMA1 Kit with Contactor

AHF filter type	Terminals
Mains voltage AHF [V]	Wire connections to transformer
230	X6-X12
380-415	X6-X13
440-480	X6-X14
500	X6-X14

Table 15: Control Voltage Setting, IP21/NEMA1 Kit with Contactor - (continued)

AHF filter type	Terminals
Mains voltage AHF [V]	Wire connections to transformer
525–575	X6–X15
600	X6–X16
690	X6–X17

5.4.2 Backplate for IP20 and IP21

To avoid false airflow when mounting the filter on rails, order a backplate. For more information, see [7.4.5 Backplate Dimensions](#).

The backplates are valid for filters revisions 1, 2, and 3.

Table 16: Selection Table, Backplate

Order number	Backplate
130B3283	X1
130B3284	X2
130B3285	X3
130B3286	X4
130B3287	X5 and X6
130B3288	X7 and X8

6 Programming

6.1 Parameter Descriptions

6.1.1 Overview of Parameter Descriptions

The parameters in this section are limited to the parameters required for operating the VLT® Advanced Harmonic Filter AHF 005/AHF 010. For reference to other parameters, refer to the *Frequency Converter Programming Guide*.

6.1.2 Parameter Group 5-0* Digital I/O mode

Table 17: 5-00 Digital I/O Mode

Option		Function
		Digital inputs and programmed digital outputs are pre-programmable for operation either in PNP or NPN systems. <div style="background-color: #004a87; color: white; text-align: center; padding: 5px;">NOTICE</div> Perform a power cycle to activate the parameter once it has been changed.
[0]*	PNP	Action on positive directional pulses (t). PNP systems are pulled down to GND.
[1]	NPN	Action on negative directional pulses (t). NPN systems are pulled up to +24 V, internally in the drive.

Table 18: 5-01 Terminal 27 Mode

Option		Function
		<div style="background-color: #004a87; color: white; text-align: center; padding: 5px;">NOTICE</div> This parameter cannot be changed while the motor is running.
[0]*	Input	Defines terminal 27 as a digital input.
[1]	Output	Defines terminal 27 as a digital output.

Table 19: 5-02 Terminal 29 Mode

Option		Function
		<div style="background-color: #004a87; color: white; text-align: center; padding: 5px;">NOTICE</div> This parameter is available for FC 302 only.
[0]*	Input	Defines terminal 19 as a digital input.
[1]	Output	Defines terminal 29 as a digital output.

6.1.3 Parameter Group 5-1* Digital Inputs

The digital inputs are used for selecting various functions in the drive. [Table 20](#) shows which functions can be assigned to digital inputs. Functions in group 1 have higher priority than the functions in group 2.

Group 1	Reset, coast stop, reset, and coast stop, quick stop, DC brake, stop, and the [Off] key.
Group 2	Start, latched start, reversing, start reversing, jog, and freeze output.

Table 20: Digital Input Functions

Digital input function	Select	Terminal
No operation	[0]	All, terminal 32, 33
Reset	[1]	All
Coast inverse	[2]	All, terminal 27
Coast and reset inverse	[3]	All
Quick stop inverse	[4]	All
DC brake inverse	[5]	All
Stop inverse	[6]	All
Start	[8]	All, terminal 18
Latched start	[9]	All
Reversing	[10]	All, terminal 19
Start reversing	[11]	All
Enable start forward	[12]	All
Enable start reverse	[13]	All
Jog	[14]	All, terminal 29
Preset reference on	[15]	All
Preset ref bit 0	[16]	All
Preset ref bit 1	[17]	All
Preset ref bit 2	[18]	All
Freeze reference	[19]	All
Freeze output	[20]	All
Speed up	[21]	All
Speed down	[22]	All
Set-up select bit 0	[23]	All
Set-up select bit 1	[24]	All
Precise stop inverse	[26]	18, 19
Precise start, stop	[17]	18, 19
Catch up	[28]	All
Slow down	[29]	All
Counter input	[30]	29, 33
Pulse input edge triggered	[31]	29, 33

Table 20: Digital Input Functions - (continued)

Digital input function	Select	Terminal
Pulse input time based	[32]	29, 33
Ramp bit 0	[34]	All
Ramp bit 1	[35]	All
Latched precise start	[40]	18, 19
Latched precise stop inverse	[41]	18, 19
External interlock	[51]	–
DigiPot increase	[55]	All
DigiPot decrease	[56]	All
DigiPot clear	[57]	All
DigiPot hoist	[58]	All
Counter A (up)	[60]	29, 33
Counter A (down)	[61]	29, 33
Reset Counter A	[62]	All
Counter B (up)	[63]	29, 33
Counter B (down)	[64]	29, 33
Reset Counter B	[65]	All
Mech. brake feedb.	[70]	All
Mech. brake feedb. inv.	[71]	All
PID error inv.	[72]	All
PID reset I-part	[73]	All
PID enable	[74]	All
MCO specific	[75]	All
PTC card 1	[80]	All
PROFIdrive OFF2	[91]	All
PROFIdrive OFF3	[92]	All
Light-load detection	[94]	All
Evacuation	[95]	All
Mains loss	[96]	32, 33
Mains loss inverse	[97]	32, 33
Start edge triggered	[98]	All
Safety option reset	[100]	–
Enable master offset	[108]	All
Start virtual master	[109]	All
Start homing	[110]	All
Activate touch	[111]	All
Relative position	[112]	All

Table 20: Digital Input Functions - (continued)

Digital input function	Select	Terminal
Enable reference	[113]	All
Sync. to Pos. mode	[114]	All
Home sensor	[115]	18, 32, 33
Home sensor inverse	[116]	18, 32, 33
Touch sensor	[117]	18, 32, 33
Touch sensor inverse	[118]	18, 32, 33
Speed mode	[119]	All
Power limit mot.	[231]	All
Power limit gen.	[232]	All
Power limit both	[233]	All
Light load + evacuation	[234]	All

VLT® AutomationDrive FC 301/FC 302 standard terminals are 18, 19, 27, 29, 32, and 33. VLT® General Purpose I/O MCB 101 terminals are X30/2, X30/3, and X30/4.

Terminal 29 functions as an output for FC 102, 103, 202 and FC 302.

Functions dedicated to only 1 digital input are stated in the associated parameter.

All digital inputs can be programmed to these functions:

Table 21: 5-10 Digital Inputs - 1

Option	Function
[0]	No operation No reaction to signals transmitted to the terminal.
[1]	Reset Resets the drive after a trip/alarm. Not all alarms can be reset.
[2]	Coast inverse (Default digital input 27): Coast stop, inverted input (NC). The drive leaves the motor in free mode. Logic 0⇒coast stop.
[3]	Coast and reset inverse Reset and coast stop inverted input (NC). Leaves the motor in free mode and resets the drive. Logic 0⇒coast stop and reset.
[4]	Quick stop inverse Inverted input (NC). Generates a stop in accordance with quick stop ramp time set in parameter 3-81 Quick Stop Ramp Time . When the motor stops, the shaft is in free mode. Logic 0⇒quick stop.
[5]	DC brake inverse Inverted input for DC brake (NC). Stops motor by energizing it with a DC current for a certain time period. See parameter 2-01 DC Brake Current to parameter 2-03 DC Brake Cut In Speed [RPM] . The function is only active when the value in parameter 2-02 DC Braking Time is different from 0. Logic 0⇒DC brake.

Table 21: 5-10 Digital Inputs - 1 - (continued)

Option		Function
[6]	Stop inverse	<p>Stop inverted function. Generates a stop function when the selected terminal goes from logical level 1 to logical level 0.</p> <p>The stop is performed according to the selected ramp time:</p> <ul style="list-style-type: none"> Parameter 3-42 Ramp 1 Ramp Downtime, Parameter 3-52 Ramp 2 Ramp Downtime, Parameter 3-62 Ramp 3 Ramp downtime, and Parameter 3-72 Ramp 4 Ramp Downtime. <div style="background-color: #004a87; color: white; text-align: center; padding: 5px;">NOTICE</div> <p>When the drive is at the torque limit and has received a stop command, it may not stop by itself. To ensure that the drive stops, configure a digital output to [27] Torque limit and stop. Connect this digital output to a digital input that is configured as coast.</p>
[8]	Start	(Default digital input 18): Select start for a start/stop command. Logic 1 = start, logic 0 = stop.
[9]	Latched start	If a pulse is applied for minimum 2 ms, the motor starts. The motor stops when stop inverse is activated, or a reset command (via DI) is given.
[10]	Reversing	(Default digital input 19). Change the direction of motor shaft rotation. Select logic 1 to reverse. The reversing signal only changes the direction of rotation. It does not activate the start function. Select both directions in parameter 4-10 Motor Speed Direction . The function is not active in process closed loop.
[11]	Start reversing	Used for start/stop and for reversing on the same wire. Signals on start are not allowed at the same time.
[12]	Enable start forward	Disengages the counterclockwise movement and allows clockwise direction.
[13]	Enable start reverse	Disengages the clockwise movement and allows counterclockwise direction.
[14]	Jog	(Default digital input 29): Activate jog speed. See parameter 3-11 Jog Speed [Hz] .
[15]	Preset reference on	Shifts between external reference and preset reference. It is assumed that [1] External/preset has been selected in parameter 3-04 Reference Function . Logic 0 = external reference active; logic 1 = 1 of the 8 preset references is active.
[16]	Preset ref bit 0	Preset reference bit 0, 1, and 2 enable a choice between 1 of the 8 preset references according to Table 22 .
[17]	Preset ref bit 1	Same as [16] Preset ref bit 0 .
[18]	Preset ref bit 2	Same as [16] Preset ref bit 0 .

Table 22: Preset Reference Bit

Preset ref. bit	2	1	0
Preset ref. 0	0	0	0
Preset ref. 1	0	0	1
Preset ref. 2	0	1	0
Preset ref. 3	0	1	1
Preset ref. 4	1	0	0

Table 22: Preset Reference Bit - (continued)

Preset ref. bit	2	1	0
Preset ref. 5	1	0	1
Preset ref. 6	1	1	0
Preset ref. 7	1	1	1

Table 23: 5-10 Digital Inputs - 2

Option	Function
[19] Freeze ref	Freezes the actual reference, which is now the point of enable/condition to be used for [21] Speed up and [22] Speed down . If speed up/speed down is used, the speed change always follows ramp 2 (parameter 3-51 Ramp 2 Ramp Up Time and parameter 3-52 Ramp 2 Ramp Downtime) in the range 0–parameter 3-03 Maximum Reference .
[20] Freeze output	Freezes the actual motor frequency (Hz), which is now the point of enable/condition to be used for [21] Speed up and [22] Speed down . If speed up/speed down is used, the speed change always follows ramp 2 (parameter 3-51 Ramp 2 Ramp Up Time and parameter 3-52 Ramp 2 Ramp Downtime) in the range 0–parameter 1-23 Motor Frequency . <div style="background-color: #004a87; color: white; text-align: center; padding: 5px;">NOTICE</div> <p>When freeze output is active, the drive cannot be stopped via a low [8] Start signal. Stop the drive via a terminal programmed for [2] Coasting inverse or [3] Coast and reset inverse.</p>
[21] Speed up	Select [21] Speed up and [22] Speed down for digital control of the up/down speed (motor potentiometer). Activate this function by selecting either [19] Freeze ref or [20] Freeze output . When speed up/speed down is activated for less than 400 ms, the resulting reference is increased/decreased by 0.1%. If speed up/speed down is activated for more than 400 ms, the resulting reference follows the setting in ramping up/down parameters 3-x1/3-x2 .

Table 24: Shut Down/Catch Up

	Shut down	Catch up
Unchanged speed	0	0
Reduced by %-value	1	0
Increased by %-value	0	1
Reduced by %-value	1	1

Table 25: 5-10 Digital Inputs - 3

Option	Function
[22] Speed down	Same as [21] Speed up .
[23] Set-up select bit 0	Select [23] Set-up select bit 0 or select [24] Set-up select bit 1 to select 1 of the 4 set-ups. Set parameter 0-10 Active Set-up to [9] Multi Set-up .
[24] Set-up select bit 1	(Default digital input 32): Same as [23] Set-up select bit 0 .
[26] Precise stop inv.	Sends an inverted stop signal when the precise stop function is activated in parameter 1-83 Precise Stop Function . Precise stop inverse function is available for terminals 18 or 19.

Table 25: 5-10 Digital Inputs - 3 - (continued)

Option		Function
[27]	Precise start, stop	<p>Use when [0] <i>Precise ramp stop</i> is selected in parameter 1-83 <i>Precise Stop Function</i>. Precise start, stop is available for terminals 18 and 19.</p> <p>Precise start ensures that the rotor turning angle from standing still to reference is the same for each start (for same ramp time, same set point). This function is the equivalent to the precise stop where the rotor turning angle from reference to standstill is the same for each stop.</p> <p>When using parameter 1-83 <i>Precise Stop Function</i> option [1] <i>Cnt stop with reset</i> or [2] <i>Cnt stop w/o reset</i>:</p> <p>The drive needs a precise stop signal before reaching the value of parameter 1-84 <i>Precise Stop Counter Value</i>. If this signal is not supplied, the drive does not stop when the value in parameter 1-84 <i>Precise Stop Counter Value</i> is reached.</p> <p>Trigger precise start, stop by a digital input. The function is available for terminals 18 and 19.</p>
[28]	Catch up	Increases reference value by percentage (relative) set in parameter 3-12 <i>Catch up/slow Down Value</i> .
[29]	Slow down	Reduces reference value by percentage (relative) set in parameter 3-12 <i>Catch up/slow Down Value</i> .
[30]	Counter input	Precise stop function in parameter 1-83 <i>Precise Stop Function</i> acts as counter stop or speed compensated counter stop with or without reset. Set the counter value in parameter 1-84 <i>Precise Stop Counter Value</i> .
[31]	Pulse edge triggered	<p>Counts the number of pulse flanks per sample time. This gives a higher resolution at high frequencies, but is not as precise at lower frequencies. Use this pulse principle for encoders with low resolution (for example 30 PPR).</p>  <p>Figure 28: Pulse Flanks per Sample Time</p>
[32]	Pulse time-based	<p>Measures the duration between pulse flanks. This gives a higher resolution at lower frequencies, but is not as precise at higher frequencies. This principle has a cutoff frequency, which makes it unsuited for encoders with low resolutions (for example 30 PPR) at low speeds.</p>  <p>Figure 29: Duration Between Pulse Flanks</p>

Table 25: 5-10 Digital Inputs - 3 - (continued)

Option		Function
[34]	Ramp bit 0	Enables a selection between 1 of the 4 ramps available, according to Table 26 .
[35]	Ramp bit 1	Same as [34] Ramp bit 0.

Table 26: Preset Ramp Bit

Preset ramp bit	1	0
Ramp 1	0	0
Ramp 2	0	1
Ramp 3	1	0
Ramp 4	1	1

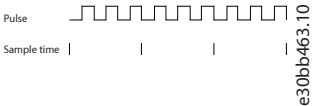
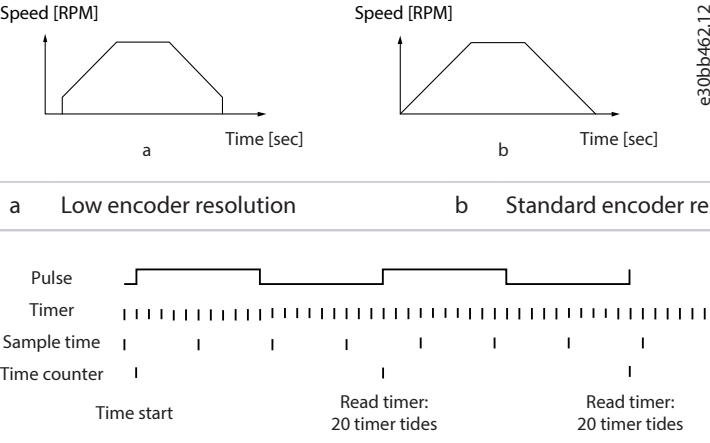
Table 27: 5-10 Digital Inputs - 4

Option		Function
[40]	Latched precise start	A latched precise start only requires a pulse of 3 ms on terminals 18 or 19. When using for parameter 1-83 Precise Stop Function [1] <i>Cnt stop with reset</i> or [2] <i>Cnt stop w/o reset</i> : When the reference is reached, the drive internally enables the precise stop signal. This means that the drive does the precise stop when the counter value of parameter 1-84 Precise Stop Counter Value is reached.
[41]	Latched precise stop inverse	Sends a latched stop signal when the precise stop function is activated in parameter 1-83 Precise Stop Function . The latched precise stop inverse function is available for terminals 18 or 19.
[51]	External interlock	This function makes it possible to give an external fault to the drive. This fault is treated in the same way as an internally generated alarm.
[55]	DigiPot increase	Increase signal to the digital potentiometer function described in parameter group 3-9* Digital Pot. Meter .
[56]	DigiPot Decrease	Decrease signal to the digital potentiometer function described in parameter group 3-9* Digital Pot. Meter .
[57]	DigiPot Clear	Clears the digital potentiometer reference described in parameter group 3-9* Digital Pot. Meter .
[60]	Counter A	(Terminal 29 or 33 only). Input for increment counting in the SLC counter.
[61]	Counter A	(Terminal 29 or 33 only). Input for decrement counting in the SLC counter.
[62]	Reset Counter A	Input for reset of counter A.
[63]	Counter B	(Terminal 29 or 33 only). Input for increment counting in the SLC counter.
[64]	Counter B	(Terminal 29 or 33 only). Input for decrement counting in the SLC counter.
[65]	Reset Counter B	Input for reset of counter B.
[70]	Mech. Brake Feedback	Brake feedback for hoisting applications: Set parameter 1-01 Motor Control Principle to [3] <i>Flux w/ motor feedback</i> ; set parameter 1-72 Start Function to [6] <i>Hoist mech brake Ref</i> .
[71]	Mech. Brake Feedback inv.	Inverted brake feedback for hoisting applications.
[72]	PID error inverse	When enabled, this option inverts the resulting error from the process PID controller. Available only if parameter 1-00 Configuration Mode is set to [6] <i>Surface Winder</i> , [7] <i>Extended PID Speed OL</i> , or [8] <i>Extended PID Speed CL</i> .

Table 27: 5-10 Digital Inputs - 4 - (continued)

Option		Function
[73]	PID reset I-part	When enabled, this option resets the I-part of the process PID controller. Equivalent to parameter 7-40 Process PID I-part Reset . Available only if parameter 1-00 Configuration Mode is set to [6] Surface Winder , [7] Extended PID Speed OL , or [8] Extended PID Speed CL .
[74]	PID enable	Enables the extended process PID controller. Equivalent to parameter 7-50 Process PID Extended PID . Available only if parameter 1-00 Configuration Mode is set to [7] Extended PID Speed OL or [8] Extended PID Speed CL .
[80]	PTC Card 1	All digital inputs can be set to [80] PTC Card 1 . However, only 1 digital input must be set to this option.
[91]	PROFIdrive OFF2	The functionality is the same as the corresponding control word bit of the PROFIBUS/PROFINET option.
[92]	PROFIdrive OFF3	The functionality is the same as the corresponding control word bit of the PROFIBUS/PROFINET option.
[94]	Light Load Detection	<p>Light-load detection is a feature for lift application to ensure that the lift runs in the evacuation direction which requires the least energy (UPS capacity), during an emergency. See parameter 30-25 Light Load Delay [s], parameter 30-26 Delay Before Measurements, parameter 30-27 Light Load Speed [%], parameter 30-28 Evacuation Speed [%], and parameter 30-29 Ramp Time for light-load detection configurations.</p> <div style="background-color: #004a87; color: white; text-align: center; padding: 5px;">NOTICE</div> <p>Flying start overrules light load detection.</p>
[95]	Evacuation	Evacuation Mode is a feature for lift application to enable drives to operate at reduced DC voltage for evacuation of the people if there is power failure. When the feature is activated, under voltage limits and enable voltage limits is reduced so that the drive can be operated with 230 V single-phase UPS-supply.
[96]	Mains loss	Select to improve kinetic backup. When the mains voltage goes back to a level that is close to (but still lower than) the detection level, the output speed increases and kinetic backup remains active. To avoid this situation, send a status signal to the drive. When the signal on the digital input is low (0), the drive forcibly turns off the kinetic backup.
		<div style="background-color: #004a87; color: white; text-align: center; padding: 5px;">NOTICE</div> <p>Only available for pulse inputs at terminals 32/33.</p>
[97]	Mains loss inverse	When the signal on the digital input is high (1), the drive forcibly turns off the kinetic backup. For more details, see the description of [96] Mains loss .
		<div style="background-color: #004a87; color: white; text-align: center; padding: 5px;">NOTICE</div> <p>Only available for pulse inputs at terminals 32/33.</p>
[98]	Start edge triggered	Edge-triggered start command. Keeps the start command alive. It can be used for a start push key.
[100]	Safe option reset	Resets the safety option. Available only when the safety option is mounted.

Table 27: 5-10 Digital Inputs - 4 - (continued)

Option		Function
[106]	Set master home	<p style="text-align: center;">NOTICE</p> <p>This option is available only with IMC software version 48.2X or newer.</p> <p>Sets actual master position to the value of parameter <i>17-88 Master Home Position</i>.</p>
[107]	Target Inverse	<p style="text-align: center;">NOTICE</p> <p>This option is available only with IMC software version 48.3X or newer.</p> <p>Changes the sign of the set target position. For example, if the set target is 1000, the activation of this option changes the value to -1000.</p>
[108]	Enable Master Offset	<p style="text-align: center;">NOTICE</p> <p>This option is available only with IMC software version 48.1X or newer.</p> <p>Activates the master offset selected in parameter <i>3-26 Master Offset</i> when parameter <i>17-93 Master Offset Selection</i> has a selection from <i>[1] Absolute</i> to <i>[5] Relative Touch Sensor</i>.</p>
[109]	Enable Vir.Master	<p style="text-align: center;">NOTICE</p> <p>This option is available only with IMC software version 48.1X or newer.</p> <p>Enable signal for the virtual master function. Only applicable when option <i>[10] Synchronization</i> is selected in parameter <i>1-00 Configuration Mode</i>.</p>
[110]	Start homing	<p style="text-align: center;">NOTICE</p> <p>This option is available only with IMC software version 48.0X or newer.</p> <p>Starts the homing function selected in parameter <i>17-80 Homing Function</i>. Must remain high until homing is done, otherwise homing is aborted.</p>
[111]	Activate touch	<p style="text-align: center;">NOTICE</p> <p>This option is available only with IMC software version 48.0X or newer.</p> <p>Activates the monitoring of the touch sensor input.</p>
[112]	Relative position	<p style="text-align: center;">NOTICE</p> <p>This option is available only with IMC software version 48.0X or newer.</p> <p>This option selects between absolute and relative positioning. The option is valid for the next positioning command.</p>

Table 27: 5-10 Digital Inputs - 4 - (continued)

Option		Function
[113]	Enable reference	<p style="text-align: center;">NOTICE</p> <p>This option is available only with IMC software version 48.0X or newer.</p> <p>Positioning mode: The drive activates the selected positioning type and target and starts the motion towards the new target. The motion starts either immediately or when active positioning is completed, depending on settings of parameter 17-90 Absolute Position Mode and parameter 17-91 Relative Position Mode. Synchronization mode: High signal locks the actual follower position to the actual master position. The follower starts and catches up with the master. Low signal stops the synchronization and the follower makes a controlled stop.</p>
[114]	Sync. to Pos. Mode	<p style="text-align: center;">NOTICE</p> <p>This option is available only with IMC software version 48.0X or newer.</p> <p>Select positioning in synchronization mode.</p>
[115]	Home sensor	<p style="text-align: center;">NOTICE</p> <p>This option is available only with IMC software version 48.0X or newer.</p> <p>Normally-open contact for defining the home position. The function is defined in parameter 17-80 Homing Function.</p>
[116]	Home sensor inv.	<p style="text-align: center;">NOTICE</p> <p>This option is available only with IMC software version 48.0X or newer.</p> <p>Normally-closed contact for defining the home position. The function is defined in parameter 17-80 Homing Function.</p>
[117]	Touch sensor	<p style="text-align: center;">NOTICE</p> <p>This option is available only with IMC software version 48.0X or newer.</p> <p>Normally-open contact. Serves as a reference for touch probe positioning.</p>
[118]	Touch sensor inv.	<p style="text-align: center;">NOTICE</p> <p>This option is available only with IMC software version 48.0X or newer.</p> <p>Normally-closed contact. Serves as a reference for touch probe positioning.</p>
[119]	Speed mode	<p style="text-align: center;">NOTICE</p> <p>This option is available only with IMC software version 48.1X or newer.</p> <p>Select the speed mode when [9] Positioning or [10] Synchronization is selected in parameter 1-00 Configuration Mode. Speed reference is set by reference resource 1 or fieldbus REF1 relative to parameter 3-03 Maximum Reference.</p>

Table 27: 5-10 Digital Inputs - 4 - (continued)

Option		Function
[122]	Position vir. Master	<p style="text-align: center;">NOTICE</p> <p>This option is available only with IMC software version 48.4X or newer.</p> <p>Activates position-controlled virtual master when [10] <i>Synchronization</i> is selected in parameter <i>1-00 Configuration Mode</i>. When the option is selected, the following occurs:</p> <ul style="list-style-type: none"> • Target position is set by Fieldbus Pos Ref or preset target is as defined in parameter <i>3-20 Preset Target</i>. • Speed is set relative to parameter <i>3-27 Virtual Master Max Ref</i> by the source selected in parameter <i>3-15 Reference Resource 1</i> or fieldbus REF1. • Acceleration and deceleration are set as defined in parameter group <i>3-6* Ramp 3</i>.
[123]	Master marker	<p style="text-align: center;">NOTICE</p> <p>This option is available only with IMC software version 48.4X or newer.</p> <p>Normally-open contact. Serves as input for master marker signal during marker synchronization based on the option selected in parameter <i>3-33 Sync. Mode & Start Behavior</i>.</p>
[124]	Master marker inv.	<p style="text-align: center;">NOTICE</p> <p>This option is available only with IMC software version 48.4X or newer.</p> <p>Normally-closed contact. Activates master marker signal for marker synchronization based on the option selected in parameter <i>3-33 Sync. Mode & Start Behavior</i>.</p>
[125]	Follower marker	<p style="text-align: center;">NOTICE</p> <p>This option is available only with IMC software version 48.4X or newer.</p> <p>Normally-open contact. Serves as input for follower marker signal during marker synchronization based on the option selected in parameter <i>3-33 Sync. Mode & Start Behavior</i>.</p>
[126]	Follower marker inv.	<p style="text-align: center;">NOTICE</p> <p>This option is available only with IMC software version 48.4X or newer.</p> <p>Normally-closed contact. Serves as input for follower marker signal during marker synchronization based on the option selected in parameter <i>3-33 Sync. Mode & Start Behavior</i>.</p>
[231]	Power limit mot.	Serves as input to activate the power limit function in the motor mode. See parameter group <i>4-8* Power Limit</i> .
[232]	Power limit gen.	Serves as input to activate the power limit function in the generating mode. See parameter group <i>4-8* Power Limit</i> .
[233]	Power limit both	Serves as input to activate the power limit function in both the motor and the generating mode. See parameter group <i>4-8* Power Limit</i> .
[234]	Light load + evacuation	Serves as input to activate the power limit function in both the motor and the generating mode. See parameter group <i>4-8* Power Limit</i> .

Table 28: 5-12 Terminal 27 Digital Input

Option	Function
Functions are described in parameter group 5-1* <i>Digital Inputs</i> .	
[0]	No operation
[1]	Reset
[2]	Coast inverse
[3]	Coast and reset inv.
[4]	Quick stop inverse
[5]	DC-brake inverse
[6]	Stop inverse
[8]	Start
[9]	Latched start
[10]	Reversing
[11]	Start reversing
[12]	Enable start forward
[13]	Enable start reverse
[14]	Jog
[15]	Preset reference on
[16]	Preset ref bit 0
[17]	Preset ref bit 1
[18]	Preset ref 2
[19]	Freeze reference
[20]	Freeze output
[21]	Speed up
[22]	Speed down
[23]	Set-up select bit 0
[24]	Set-up select bit 1
[28]	Catch up
[29]	Slow down
[34]	Ramp bit 0
[35]	Ramp bit 1
[44]	Restart drive
[51]	External interlock
[55]	DigitPot increase
[56]	DigitPot decrease
[57]	DigitPot clear
[58]	DigitPot Hoist
[62]	Reset Counter A

Table 28: 5-12 Terminal 27 Digital Input - (continued)

Option	Function
[65]	Reset Counter B
[70]	Mech. brake feedb.
[71]	Mech. brake feedb. inv.
[72]	PID error inverse
[73]	PID reset I part
[74]	PID enable
[75]	MCO specific
[78]	Reset main. word
[80]	PTC card 1
[91]	PROFIdrive OFF2
[92]	PROFIdrive OFF3
[94]	Light load detection
[96]	Mains loss
[97]	Mains loss inverse
[98]	Start edge triggered
[100]	Safe option reset
[107]	Target inverse
[108]	Enable master offset
[109]	Start virtual master
[110]	Start homing
[111]	Activate touch
[112]	Relative position
[113]	Enable reference
[114]	Sync. to pos. mode
[115]	Home sensor
[116]	Home sensor inv.
[117]	Touch sensor
[118]	Touch sensor inv.
[119]	Speed mode
[231]	Power limit mot.
[232]	Power limit gen.
[233]	Power limit both

Table 29: 5-13 Terminal 29 Digital Input

Option	Function
Select the function from the available digital input range and the additional options [60] Counter A, [61] Counter A, [63] Counter B, and [64] Counter B. Counters are used in smart logic control functions.	
NOTICE	
This parameter is not available for FC 301.	
Functions are described in parameter group 5-1* Digital Inputs.	
[0]	No operation
[1]	Reset
[2]	Coast inverse
[3]	Coast and reset inv.
[4]	Quick stop inverse
[5]	DC-brake inverse
[6]	Stop inverse
[8]	Start
[9]	Latched start
[10]	Reversing
[11]	Start reversing
[12]	Enable start forward
[13]	Enable start reverse
[14]	Jog
[15]	Preset reference on
[16]	Preset ref bit 0
[17]	Preset ref bit 1
[18]	Preset ref bit 2
[19]	Freeze reference
[20]	Freeze output
[21]	Speed up
[22]	Speed down
[23]	Set-up select bit 0
[24]	Set-up select bit 1
[28]	Catch up
[29]	Slow down
[30]	Counter input
[31]	Pulse edge triggered
[32]	Pulse time based
[34]	Ramp bit 0
[35]	Ramp bit 1

Table 29: 5-13 Terminal 29 Digital Input - (continued)

Option	Function
[44]	Restart drive
[51]	External interlock
[55]	DigiPot increase
[56]	DigiPot decrease
[57]	DigiPot clear
[58]	DigiPot hoist
[60]	Counter A (up)
[61]	Counter A (down)
[62]	Reset Counter A
[63]	Counter B (up)
[64]	Counter B (down)
[65]	Reset Counter B
[70]	Merch. brake feedb.
[71]	Mech. brake feedb. inv.
[72]	PID error inverse
[73]	PID reset I-part
[74]	PID enable
[75]	MCO specific
[78]	Reset main. word
[80]	PTC card 1
[91]	PROFIdrive OFF2
[92]	PROFIdrive OFF3
[94]	Light load detection
[96]	Mains loss
[97]	Mains loss inverse
[98]	Start edge triggered
[100]	Safe option reset
[107]	Target inverse
[108]	Enable master offset
[109]	Start virtual master
[110]	Start homing
[111]	Activate touch
[112]	Relative position
[113]	Enable reference
[114]	Sync. to Pos. mode
[115]	Home sensor

Table 29: 5-13 Terminal 29 Digital Input - (continued)

Option	Function
[116]	Home sensor inv.
[117]	Touch sensor
[118]	Touch sensor inv.
[119]	Speed mode
[231]	Power limit mot.
[232]	Power limit gen.
[233]	Power limit both

6.1.4 Parameter Group 5-3* Digital Outputs

5-30 Terminal 27 Digital Output

This manual only shows the option relevant for the VLT® Advanced Harmonic Filter AHF 005/AHF 010. Refer to the *Frequency Converter Programming Guide* for the complete list of options in this parameter.

Table 30: 5-30 Terminal 27 Digital Output

Option:	Function:
[188] AHF Capacitor Connect	<p>This function is not suitable when multiple frequency converters are connected to a single filter.</p> <p>The capacitors are turned on at 20% (hysteresis of 50% gives an interval of 10–30%). The capacitors are disconnected below 10%. The off delay is 10 s and restarts if the nominal power goes above 10% during the delay.</p> <p>Parameter 5-80 AHF Cap Reconnect Delay is used to guarantee a minimum off-time for the capacitors.</p>

5-40 Function Relay

This manual only shows the option relevant for the VLT® Advanced Harmonic Filter AHF 005/AHF 010. Refer to the frequency converter programming guide for the complete list of options in this parameter.

Table 31: 5-40 Function Relay

Option:	Function:
[188] AHF Capacitor Connect	<p>This function is not suitable when multiple frequency converters are connected to a single filter.</p> <p>The capacitors are turned on at 20% (hysteresis of 50% gives an interval of 10–30%). The capacitors are disconnected below 10%. The off delay is 10 s and restarts if the nominal power goes above 10% during the delay.</p> <p>Parameter 5-80 AHF Cap Reconnect Delay is used to guarantee a minimum off-time for the capacitors.</p>

5-80 AHF Cap Reconnect Delay

Table 32: 5-80 AHF Cap Reconnect Delay

Range:	Function:
25 s* [1–120 s]	Guarantees a minimum off-time for the capacitors. The timer starts once the AHF capacitor disconnects and has to expire before the output is allowed to be on again. It only turns on again if the frequency converter power is 20–30%.

6.1.5 DC-link Compensation Disabling

NOTICE

To prevent resonances in the DC link, disable the dynamic DC-link compensation by setting parameter **14-51 DC-link Compensation** to **[0] Off**.

The FC series drives include a feature which ensures that the output voltage is independent of any voltage fluctuation in the DC link, for example, caused by fast fluctuation in the mains supply voltage. Sometimes, this dynamic compensation can produce resonances in the DC link and should then be disabled. Typical cases are where the VLT® Advanced Harmonic Filter AHF 005/AHF 010 is used on supply grids with high short-circuit ratio. Fluctuations can often be recognized by increased acoustic noise and, in extreme cases, by unintended tripping.

Parameter 14-51 DC-Link Compensation

Table 33: 14-51 DC-Link Compensation

Option:		Function:
		<p>The rectified AC-DC voltage in the frequency converter's DC link is associated with voltage ripples.</p> <p>These ripples can increase in magnitude with increased load.</p> <p>These ripples are undesirable because they can generate current and torque ripples. A compensation method is used to reduce these voltage ripples in the DC link. In general, DC-link compensation is recommended for most applications, but pay attention when operating in field weakening as it can generate speed oscillations at the motor shaft. In field weakening, turn off DC-link compensation.</p>
[0]	Off	Disables DC-link compensation.
[1]	On	Enables DC-link compensation.

7 Specifications

7.1 General Specifications

Table 34: General Technical Data

Data	Value
Mains supply types ⁽¹⁾	380 V/60 Hz
	400 V/50 Hz
	460 V/60 Hz
	600 V/60 Hz
	690 V/50 Hz
Nominal supply voltages ⁽¹⁾	380–415 V/60 Hz
	380–415 V/50 Hz
	440–480 V/60 Hz
	525–690 V /60 Hz
	525–690 V/50Hz
Supply voltage tolerance	±10%
Tolerances of the actual supply voltage	342–456 V/60 Hz
	342–456 V/50 Hz
	396–528 V/60 Hz
	472–759 V/60 Hz
	472–759 V/50 Hz
Supply frequency tolerance	±2%
Power loss	See 7.3 Power Loss and Acoustic Noise Level .
Acoustic noise level	See 7.3 Power Loss and Acoustic Noise Level .
Overload capacity	160% for 60 s every 10 minutes
Efficiency	>0.98
THDi ⁽²⁾	AHF 005 <5%
	AHF 010 <10%
Cos φ of I _L	0.5 cap at 25% I _{AHF,N}
	0.8 cap at 50% I _{AHF,N}
	0.85 cap at 75% I _{AHF,N}
	0.99 cap at 100% I _{AHF,N}
	1.0 cap at 160% I _{AHF,N}
Power derating - temperature	Without derating: 5–45 °C (41–113 °F) With derating: 45–60 °C (113–140 °F) 1.5% per degree. See Figure 30 .

Table 34: General Technical Data - (continued)

Data	Value
Power derating - altitude above sea level	1000 m (3280 ft) without derating
	1000–4000 m (3280–13123 ft) 5% per 1000 m (3280 ft)

- 1) *The fan control system supports extended input voltage range as 200–415 V for the 380 V/60 Hz and 400 V/50 Hz programs. The 380 V/60 Hz and the 400 V/50 Hz programs can be operated with 200–240 V mains supply. The 525–690 V/60 Hz range series is UL certified for 600 V applications, but can be used for 690 V/60 Hz applications as well.*
- 2) *THDi level is system level performance from the filter combined with the actual drive.*

NOTICE

The reduction of the low-harmonic current emission to the rated THDi implies that the THDv of the non-influenced mains voltage is lower than 2%, and the ratio of short-circuit power to installed load (R_{SCE}) is above 66. Under these conditions, the THDi of the mains current of the drive is reduced to 10% or 5% (typical values at nominal load). If these conditions are not or only partially fulfilled, a significant reduction of the harmonic components can still be achieved, but the rated THDi values may not be observed.

7.2 Environmental Data

Table 35: Environmental Data

Data	Value
Ambient temperature during operation	5–45 °C (41–113 °F) without derating
	45–60 °C (113–140 °F) with derating 1.5% per °C. See Figure 30
Temperature during storage and transportation	Transport: -25 °C to +55 °C (-13 °F to +149 °F)
	Storage: -25 °C to +55 °C (-13 °F to +131 °F)
Maximum altitude above sea level	1000 m (3280 ft) without derating
	1000–4000 m (3280–13123 ft) with derating 5% per 1000 m (3280 ft)
Relative humidity	Humidity class F without condensation 5–85% - Class 3K3 (non-condensing) during operation
Resonance search	Base standard: DIN EN 600068-2-6
	Test specifications: 5 Hz, 150 Hz 3 directions (0.5 g, 0.1 g, 0.5 g)
Sine vibration test	Base standard: DIN EN 600068-2-6
	Test specifications: 5–13.2 Hz, 150 Hz (2 mm (0.08 in) peak-to-peak 0.7 g)
Packaging	ISPM 15
Enclosure protection rating	IP20
	Optional IP21/NEMA 1 upgrade kits
Approvals	CE
	The Low Voltage Directive
	UL ⁽¹⁾
	UL SCCR 100 kA

Table 35: Environmental Data - (continued)

Data	Value
Standards	Radiated immunity, IEC 61800-3, 2012 edition 2.1
	Burst, EN 61000-4-4
	Surge, EN 61000-4-5
	ESD, EN 61000-4-2
	Radiated field-CM, IEC 61800-3, 2012 edition 2.1
	PELV in accordance to EN 61800-5-1 for the temperature switches.

1) UL certified for 460 V/60 Hz and 600 V/60 Hz versions. UL listing card reference ID number: E134261.

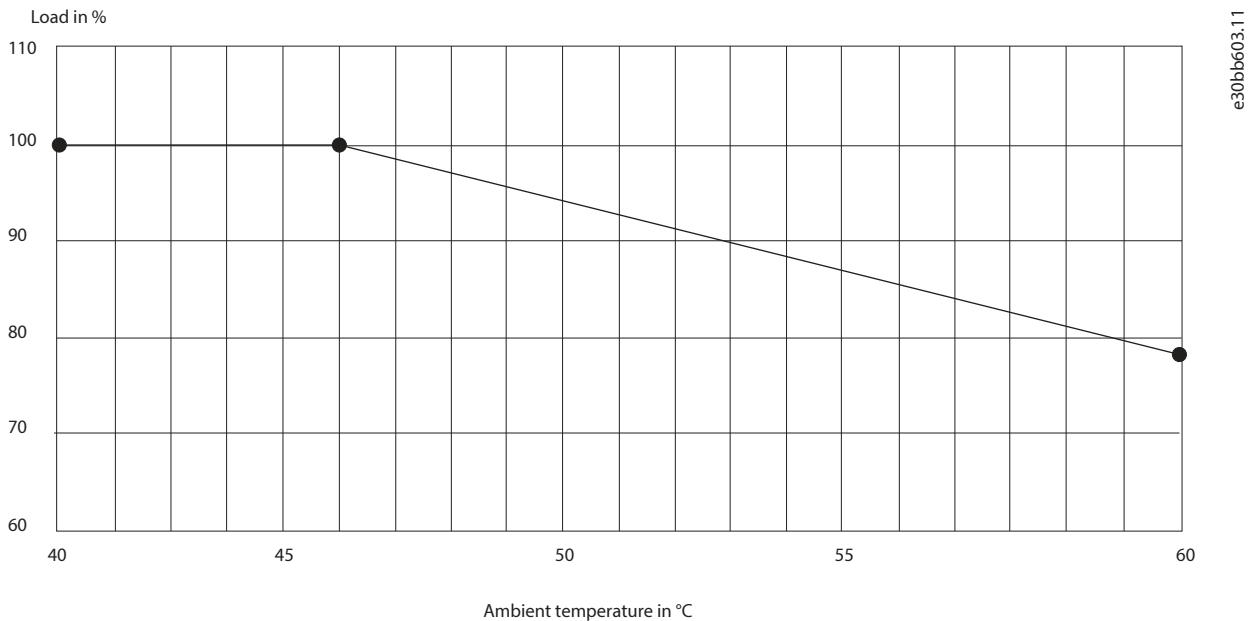

Figure 30: Temperature Derating Curve

7.3 Power Loss and Acoustic Noise Level

Table 36 explains in detail the terminology used in the power loss and acoustic noise level tables. See Table 37 to Table 41.

Table 36: Terminology in Power Loss and Acoustic Noise Level Tables

Value	Description
Current rating	Filter nominal current rating.
Code numbers	AHF part number for ordering.
AHF 005	AHF version with performance level of 5% THDi or better at system level with nominal load.
AHF 010	AHF version with performance level of 10% THDi or better at system level with nominal load.
Power loss	Power loss according to EN 50598 Eco design for PDS at percentage load (0, 25, 50, 75, 100) of nominal current. The power loss references are with 25 °C (77 °F) ambient temperature.
Acoustic noise level	Maximum acoustical noise level from filter at 1 m (3.28 ft) distance with nominal loading at 25 °C (77 °F) ambient temperature. Maximum level typical at nominal loading.

NOTICE

The following tables are only valid for VLT® Advanced Harmonic Filter AHF 005/AHF 010 revision 03.

Table 37: Power Loss and Acoustic Noise Level, 380–415 V, 50 Hz

380–415 V, 50 Hz	AHF 005						AHF 010								
	Current rating [A]	Code number [P/N]	Power loss at percentage load of nominal current					Acoustic noise [dB(A)]	Code number [P/N]	Power loss at percentage load of nominal current					Acoustic noise [dB(A)]
			0% [W]	25% [W]	50% [W]	75% [W]	100% [W]			0% [W]	25% [W]	50% [W]	75% [W]	100% [W]	
10	130B1229	28	36	66	91	142	<70	130B1027	17	22	38	54	86	<70	
14	130B1231	37	56	85	132	177	<70	130B1058	36	50	72	106	137	<70	
22	130B1232	59	84	129	202	286	<70	130B1059	52	73	110	165	229	<70	
29	130B1233	75	106	165	259	357	<70	130B1089	65	87	127	188	248	<70	
34	130B1238	79	112	189	296	425	<72	130B1094	60	83	129	203	285	<72	
40	130B1239	81	122	202	311	457	<72	130B1111	57	86	142	214	317	<72	
55	130B1240	73	117	217	361	541	<72	130B1176	59	92	160	259	387	<72	
66	130B1241	96	163	288	478	717	<72	130B1180	71	117	201	334	512	<72	
82	130B1247	100	171	296	491	733	<72	130B1201	83	125	197	302	447	<72	
96	130B1248	117	177	305	477	699	<75	130B1204	108	157	254	385	554	<75	
133	130B1249	127	211	356	581	873	<75	130B1207	117	185	307	493	737	<75	
171	130B1250	159	272	493	823	1215	<75	130B1213	141	227	375	593	895	<75	
204	130B1251	214	318	527	837	1253	<75	130B1214	146	231	380	598	905	<75	
251	130B1258	291	322	556	896	1366	<75	130B1215	197	312	504	786	1194	<75	
304	130B1259	292	407	662	991	1505	<75	130B1216	240	361	584	880	1352	<75	
325	130B3152	267	395	679	1083	1656	<75	130B3136	252	367	593	921	1385	<75	
381	130B1260	282	416	718	1265	2009	<75	130B1217	279	386	676	1072	1617	<75	
480	130B1261	408	604	1039	1848	2623	<77	130B1228	390	593	984	1616	2347	<77	

Table 38: Power Loss and Acoustic Noise Level, 380–415 V, 60 Hz

380–415 V, 60 Hz	AHF 005						AHF 010								
	Current rating [A]	Code number [P/N]	Power loss at percentage load of nominal current					Acoustic noise [dB(A)]	Code number [P/N]	Power loss at percentage load of nominal current					Acoustic noise [dB(A)]
			0% [W]	25% [W]	50% [W]	75% [W]	100% [W]			0% [W]	25% [W]	50% [W]	75% [W]	100% [W]	
10	130B2857	28	36	66	91	142	<70	130B2262	17	22	38	54	86	<70	
14	130B2858	37	56	85	132	177	<70	130B2265	36	50	72	106	137	<70	
22	130B2859	59	84	129	202	286	<70	130B2268	52	73	110	165	229	<70	
29	130B2860	75	106	165	259	357	<70	130B2294	65	87	127	188	248	<70	
34	130B2861	79	112	189	296	425	<72	130B2297	60	83	129	203	285	<72	
40	130B2862	81	122	202	311	457	<72	130B2303	57	86	142	214	317	<72	
55	130B2863	73	117	217	361	541	<72	130B2445	59	92	160	259	387	<72	
66	130B2864	96	163	288	478	717	<72	130B2459	71	117	201	334	512	<72	
82	130B2865	100	171	296	491	733	<72	130B2488	83	125	197	302	447	<72	
96	130B2866	117	177	305	477	699	<75	130B2489	108	157	254	385	554	<75	
133	130B2867	127	211	356	581	873	<75	130B2498	117	185	307	493	737	<75	
171	130B2868	159	272	493	823	1215	<75	130B2499	141	227	375	593	895	<75	
204	130B2869	214	318	527	837	1253	<75	130B2500	146	231	380	598	905	<75	
251	130B2870	291	322	556	896	1366	<75	130B2700	197	312	504	786	1194	<75	
304	130B2871	292	407	662	991	1505	<75	130B2819	240	361	584	880	1352	<75	
325	130B3156	267	395	679	1083	1656	<75	130B3154	252	367	593	921	1385	<75	
381	130B2872	282	416	718	1265	2009	<75	130B2855	279	386	676	1072	1617	<75	
480	130B2873	408	604	1039	1848	2623	<77	130B2856	390	593	984	1616	2347	<77	

Table 39: Power Loss and Acoustic Noise Level, AHF 005, 440–480 V, 60 Hz

440–480 V, 60 Hz	AHF 005						AHF 010								
	Current rating [A]	Code number [P/N]	Power loss at percentage load of nominal current					Acoustic noise [dB(A)]	Code number [P/N]	Power loss at percentage load of nominal current					Acoustic noise [dB(A)]
			0% [W]	25% [W]	50% [W]	75% [W]	100% [W]			0% [W]	25% [W]	50% [W]	75% [W]	100% [W]	
10	130B1752	32	41	76	105	163	<70	130B1482	20	26	44	62	99	<70	
14	130B1753	47	68	100	154	206	<70	130B1483	45	61	86	124	160	<70	
19	130B1754	58	83	128	201	283	<70	130B1484	51	73	110	164	227	<70	
25	130B1755	74	104	163	257	354	<70	130B1485	64	86	126	186	245	<70	
31	130B1756	85	120	200	312	448	<72	130B1486	65	89	137	215	301	<72	
36	130B1757	85	128	210	323	474	<72	130B1487	61	91	148	223	329	<72	
48	130B1758	73	118	218	363	543	<72	130B1488	59	92	161	260	389	<72	
60	130B1759	102	172	302	502	751	<72	130B1491	76	124	212	351	537	<72	
73	130B1760	103	176	304	503	751	<72	130B1492	86	129	202	310	458	<72	
95	130B1761	139	207	352	547	801	<75	130B1493	129	185	294	443	635	<75	
118	130B1762	130	216	364	594	891	<75	130B1494	120	190	314	504	753	<75	
154	130B1763	166	283	512	854	1260	<75	130B1495	148	236	389	615	928	<75	
183	130B1764	222	329	545	864	1293	<75	130B1496	152	240	393	618	935	<75	
231	130B1765	313	345	593	953	1450	<75	130B1497	214	335	538	836	1267	<75	
291	130B1766	330	456	658	1098	1664	<75	130B1498	273	405	650	975	1496	<75	
355	130B1768	358	517	723	1379	2098	<75	130B1499	339	482	763	1175	1758	<75	
380	130B3167	336	489	663	1462	2314	<75	130B3165	333	455	786	1239	1864	<75	
436	130B1769	430	635	970	1933	2743	<77	130B1751	411	623	1031	1691	2454	<77	

Table 40: Power Loss and Acoustic Noise Level, 600 V, 60 Hz

600 V, 60 Hz	AHF 005							AHF 010							
	Current rating [A]	Code number [P/N]	Power loss at percentage load of nominal current					Acoustic noise [dB(A)]	Code number [P/N]	Power loss at percentage load of nominal current					Acoustic noise [dB(A)]
			0% [W]	25% [W]	50% [W]	75% [W]	100% [W]			0% [W]	25% [W]	50% [W]	75% [W]	100% [W]	
15	130B5246	53	78	131	206	301	<70	130B5212	47	70	112	169	245	<70	
20	130B5247	71	102	169	265	388	<70	130B5213	55	79	126	190	276	<70	
24	130B5248	79	113	187	293	428	<70	130B5214	64	91	144	217	315	<70	
29	130B5249	84	120	196	308	450	<70	130B5215	68	97	152	228	331	<70	
36	130B5250	118	165	267	418	611	<70	130B5216	94	132	204	307	445	<70	
50	130B5251	121	169	273	427	624	<70	130B5217	96	135	208	313	454	<70	
58	130B5252	135	188	302	473	691	<70	130B5218	115	159	244	366	531	<70	
77	130B5253	172	238	381	595	870	<72	130B5219	147	203	308	462	669	<72	
87	130B5254	200	275	438	685	1001	<72	130B5220	171	234	354	531	770	<72	
109	130B5255	208	285	454	710	1038	<72	130B5221	178	243	367	551	798	<72	
128	130B5256	219	300	478	747	1091	<72	130B5222	204	278	418	627	909	<72	
155	130B5257	272	379	611	955	1397	<72	130B5223	253	350	535	803	1164	<72	
197	130B5258	296	410	659	1031	1507	<72	130B5224	290	399	605	908	1317	<72	
240	130B5259	364	502	801	1253	1831	<75	130B5225	354	484	731	1097	1591	<75	
296	130B5260	486	667	1058	1653	2416	<75	130B5226	474	644	966	1449	2100	<75	
366	–	–	–	–	–	–	–	130B5227	592	801	1197	1795	2600	<75	
395	–	–	–	–	–	–	–	130B5228	641	867	1293	1938	2808	<75	

Table 41: Power Loss and Acoustic Noise Level, AHF 005, 500–690 V, 50 Hz

500–690 V, 50 Hz	AHF 005							AHF 010							
	Current rating [A]	Code number [P/N]	Power loss at percentage load of nominal current					Acoustic noise [dB(A)]	Code number [P/N]	Power loss at percentage load of nominal current					Acoustic noise [dB(A)]
			0% [W]	25% [W]	50% [W]	75% [W]	100% [W]			0% [W]	25% [W]	50% [W]	75% [W]	100% [W]	
15	130B5088	62	90	151	237	347	<70	130B5280	56	81	129	194	282	<70	
20	130B5089	83	118	195	305	446	<70	130B5281	64	92	146	219	318	<70	
24	130B5090	93	132	215	337	493	<70	130B5282	75	106	166	249	362	<70	
29	130B5092	98	139	226	354	518	<70	130B5283	79	112	175	263	381	<70	
36	130B5125	137	191	307	481	703	<70	130B5284	110	153	235	353	512	<70	
50	130B5144	140	195	314	491	718	<70	130B5285	113	156	240	360	522	<70	
58	130B5168	156	217	348	544	795	<70	130B5286	134	184	281	421	611	<70	
77	130B5169	200	275	438	685	1001	<72	130B5287	171	234	354	531	770	<72	
87	130B5170	231	318	504	788	1152	<72	130B5288	198	271	407	611	886	<72	
109	130B5172	240	330	523	817	1194	<72	130B5289	206	281	422	633	918	<72	
128	130B5195	253	347	550	859	1255	<72	130B5290	236	321	481	722	1046	<72	
155	130B5196	316	439	703	1099	1607	<72	130B5291	295	405	615	924	1339	<72	
197	130B5197	343	474	759	1186	1734	<72	130B5292	336	461	696	1045	1515	<72	
240	130B5198	421	579	922	1441	2106	<75	130B5293	411	560	842	1263	1830	<75	
296	130B5199	563	769	1217	1902	2779	<75	130B5294	549	743	1112	1667	2416	<75	
366	–	–	–	–	–	–	–	130B5295	684	924	1377	2064	2991	<75	
395	–	–	–	–	–	–	–	130B5296	741	999	1487	2230	3230	<75	

7.4 Mechanical Dimensions

7.4.1 Overview of Mechanical Dimensions

The dimensions and code numbers of the VLT® Advanced Harmonic Filters AHF 005/AHF 010 can be found in [Table 42](#) to [Table 51](#).

Table 42: AHF 005, 380–415 V, 50 Hz

380–415 V 50 Hz		AHF 005				
Current rating [A]	Code number [P/ N]	Dimensions			Weight [kg (lb)]	Enclosure type
		Height [mm (in)]	Width [mm (in)]	Depth [mm (in)]		
10	130B1229	322 (12.7)	196 (7.7)	205 (8.1)	18 (40)	X1-V3 IP20 if
14	130B1231	342 (13.5)	196 (7.7)	205 (8.1)	19 (42)	X1-V3 IP20 ef
22	130B1232	454 (17.9)	238 (9.4)	248 (9.8)	29 (64)	X2-V3 IP20 ef
29	130B1233	454 (17.9)	238 (9.4)	248 (9.8)	33 (73)	X2-V3 IP20 ef
34	130B1238	592 (23.3)	378 (14.9)	245 (9.6)	52 (115)	X3-V3 IP20 if
40	130B1239	592 (23.3)	378 (14.9)	245 (9.6)	53 (117)	X3-V3 IP20 if
55	130B1240	592 (23.3)	378 (14.9)	245 (9.6)	58 (128)	X3-V3 IP20 if
66	130B1241	621(24.5)	378 (14.9)	338 (13.3)	76 (168)	X4-V3 IP20 if
82	130B1247	621 (24.5)	378 (14.9)	338 (13.3)	98(216)	X4-V3 IP20 ef
96	130B1248	736 (29)	418 (16.5)	333 (13.1)	104 (229)	X5-V3 IP20 ef
133	130B1249	736 (29)	418 (16.5)	333 (13.1)	106 (234)	X5-V3 IP20 ef
171	130B1250	764 (30.1)	418 (16.5)	405 (15.9)	126 (278)	X6-V3 IP20 ef
204	130B1251	764 (30.1)	418 (16.5)	405 (15.9)	135 (298)	X6-V3 IP20 ef
251	130B1258	957 (37.7)	468 (18.4)	451 (17.8)	172 (379)	X7-V3 IP20 if
304	130B1259	957 (37.7)	468 (18.4)	451 (17.8)	206 (454)	X7-V3 IP20 if
325	130B3152	957 (37.7)	468 (18.4)	515 (20.3)	221 (487)	X8-V3 IP20 if
381	130B1260	957 (37.7)	468 (18.4)	515 (20.3)	230 (507)	X8-V3 IP20 ef
480	130B1261	957 (37.7)	468 (18.4)	515 (20.3)	272 (600)	X8-V3 IP20 ef

Table 43: AHF 010, 380–415 V, 50 Hz

380–415 V 50 Hz		AHF 010				
Current rating [A]	Code number [P/ N]	Dimensions			Weight [kg]	Enclosure type
		Height [mm (in)]	Width [mm (in)]	Depth [mm (in)]		
10	130B1027	322 (12.7)	196 (7.7)	205 (8.1)	13.5 (30)	X1-V3 IP20 if
14	130B1058	342 (13.5)	196 (7.7)	205 (8.1)	15.2 (34)	X1-V3 IP20 ef
22	130B1059	434 (17.1)	238 (9.4)	248 (9.8)	21 (47)	X2-V3 IP20 if
29	130B1089	434 (17.1)	238 (9.4)	248 (9.8)	24 (53)	X2-V3 IP20 if
34	130B1094	592 (23.3)	378 (14.9)	245 (9.6)	33 (73)	X3-V3 IP20 if

Table 43: AHF 010, 380–415 V, 50 Hz - (continued)

380–415 V 50 Hz		AHF 010				
Current rating [A]	Code number [P/ N]	Dimensions			Weight [kg]	Enclosure type
		Height [mm (in)]	Width [mm (in)]	Depth [mm (in)]		
40	130B1111	592 (23.3)	378 (14.9)	245 (9.6)	37 (82)	X3-V3 IP20 if
55	130B1176	592 (23.3)	378 (14.9)	245 (9.6)	39 (86)	X3-V3 IP20 if
66	130B1180	621 (24.5)	378 (14.9)	338 (13.3)	44 (97)	X4-V3 IP20 if
82	130B1201	621 (24.5)	378 (14.9)	338 (13.3)	56 (123)	X4-V3 IP20 ef
96	130B1204	736 (29)	418 (16.5)	333 (13.1)	62 (137)	X5-V3 IP20 ef
133	130B1207	736 (29)	418 (16.5)	333 (13.1)	74 (164)	X5-V3 IP20 ef
171	130B1213	764 (30.1)	418 (16.5)	405 (15.9)	85 (187)	X6-V3 IP20 if
204	130B1214	764 (30.1)	418 (16.5)	405 (15.9)	102 (225)	X6-V3 IP20 if
251	130B1215	957 (37.7)	468 (18.4)	451 (17.8)	119 (262)	X7-V3 IP20 if
304	130B1216	957 (37.7)	468 (18.4)	451 (17.8)	136	X7-V3 IP20 if
325	130B3136	957 (37.7)	468 (18.4)	451 (17.8)	142	X7-V3 IP20 if
381	130B1217	957 (37.7)	468 (18.4)	451 (17.8)	163	X7-V3 IP20 if
480	130B1228	957 (37.7)	468 (18.4)	515 (20.3)	205 (452)	X8-V3 IP20 ef

Table 44: AHF 005, 380–415 V, 60 Hz

380–415 V 60 Hz		AHF 005				
Current rating [A]	Code number [P/ N]	Dimensions			Weight [kg (lb)]	Enclosure type
		Height [mm (in)]	Width [mm (in)]	Depth [mm (in)]		
10	130B2857	322 (12.7)	196 (7.7)	205 (8.1)	18 (40)	X1-V3 IP20 if
14	130B2858	342 (13.5)	196 (7.7)	205 (8.1)	19 (42)	X1-V3 IP20 ef
22	130B2859	454 (17.1)	238 (9.4)	248 (9.8)	29 (64)	X2-V3 IP20 ef
29	130B2860	454 (17.1)	238 (9.4)	248 (9.8)	33 (73)	X2-V3 IP20 ef
34	130B2861	592 (23.3)	378 (14.9)	245 (9.6)	52 (115)	X3-V3 IP20 if
40	130B2862	592 (23.3)	378 (14.9)	245 (9.6)	53 (117)	X3-V3 IP20 if
55	130B2863	592 (23.3)	378 (14.9)	245 (9.6)	58 (128)	X3-V3 IP20 if
66	130B2864	621 (24.5)	378 (14.9)	338 (13.3)	76 (168)	X4-V3 IP20 if
82	130B2865	621 (24.5)	378 (14.9)	338 (13.3)	98 (216)	X4-V3 IP20 ef
96	130B2866	736 (29)	418 (16.5)	333 (13.1)	104 (230)	X5-V3 IP20 ef
133	130B2867	736 (29)	418 (16.5)	333 (13.1)	106 (234)	X5-V3 IP20 ef
171	130B2868	764 (30.1)	418 (16.5)	405 (15.9)	126 (278)	X6-V3 IP20 ef
204	130B2869	764 (30.1)	418 (16.5)	405 (15.)	135 (296)	X6-V3 IP20 ef
251	130B2870	957 (37.7)	468 (18.4)	451 (17.8)	172 (380)	X7-V3 IP20 if

Table 44: AHF 005, 380–415 V, 60 Hz - (continued)

380–415 V 60 Hz		AHF 005				
Current rating [A]	Code number [P/ N]	Dimensions			Weight [kg (lb)]	Enclosure type
		Height [mm (in)]	Width [mm (in)]	Depth [mm (in)]		
304	130B2871	957 (37.7)	468 (18.4)	515 (20.3)	221 (488)	X8-V3 IP20 if
325	130B3156	957 (37.7)	468 (18.4)	515 (20.3)	230 (507)	X8-V3 IP20 ef
381	130B2872	957 (37.7)	468 (18.4)	515 (20.3)	265 (585)	X8-V3 IP20 ef
480	130B2873	957 (37.7)	468 (18.4)	515 (20.3)	272 (600)	X8-V3 IP20 ef

Table 45: AHF 010, 380–415 V, 60 Hz

380–415 V 60 Hz		AHF 010				
Current rating [A]	Code number [P/ N]	Dimensions			Weight [kg (lb)]	Enclosure type
		Height [mm (in)]	Width [mm (in)]	Depth [mm (in)]		
10	130B2262	322 (12.7)	196 (7.7)	205 (8.1)	13.5 (29.8)	X1-V3 IP20 if
14	130B2265	342 (13.5)	196 (7.7)	205 (8.1)	15.2 (33.5)	X1-V3 IP20 ef
22	130B2268	434 (17.1)	238 (9.4)	248 (9.8)	21 (47)	X2-V3 IP20 if
29	130B2294	434 (17.1)	238 (9.4)	248 (9.8)	24 (53)	X2-V3 IP20 if
34	130B2297	592 (23.3)	378 (14.9)	245 (9.6)	33 (73)	X3-V3 IP20 if
40	130B2303	592 (23.3)	378 (14.9)	245 (9.6)	37 (82)	X3-V3 IP20 if
55	130B2445	592 (23.3)	378 (14.9)	245 (9.6)	39 (86)	X3-V3 IP20 if
66	130B2459	621 (24.5)	378 (14.9)	338 (13.3)	44 (97)	X4-V3 IP20 if
82	130B2488	621 (24.5)	378 (14.9)	338 (13.3)	56 (123)	X4-V3 IP20 ef
96	130B2489	736 (29)	418 (16.5)	333 (13.1)	62 (137)	X5-V3 IP20 ef
133	130B2498	736 (26)	418 (16.5)	333 (13.1)	74 (164)	X5-V3 IP20 ef
171	130B2499	764 (30.1)	418 (16.5)	405 (15.9)	85 (187)	X6-V3 IP20 if
204	130B2500	764 (30.1)	418 (16.5)	405 (15.9)	102 (225)	X6-V3 IP20 if
251	130B2700	957 (37.7)	468 (18.4)	451 (17.8)	119 (262)	X7-V3 IP20 if
304	130B2819	957 (37.7)	468 (18.4)	451 (17.8)	142 (313)	X7-V3 IP20 if
325	130B3154	957 (37.7)	468 (18.4)	451 (17.8)	163 (359)	X7-V3 IP20 ef
381	130B2855	957 (37.7)	468 (18.4)	451 (17.8)	172 (380)	X7-V3 IP20 ef
480	130B2856	957 (37.7)	468 (18.4)	515 (20.3)	205 (452)	X8-V3 IP20 ef

Table 46: AHF 005, 440–480 V, 60 Hz

440–480 V 60 Hz		AHF 005				
Current rating [A]	Code number [P/ N]	Dimensions			Weight [kg (lb)]	Enclosure type
		Height [mm (in)]	Width [mm (in)]	Depth [mm (in)]		
10	130B1752	322 (12.7)	196 (7.7)	205 (8.1)	18 (40)	X1-V3 IP20 if
14	130B1753	342 (13.5)	196 (7.7)	205 (8.1)	19 (42)	X1-V3 IP20 ef
19	130B1754	454 (17.1)	238 (9.4)	248 (9.8)	29 (64)	X2-V3 IP20 ef
25	130B1755	454 (17.1)	238 (9.4)	248 (9.8)	33 (73)	X2-V3 IP20 ef
31	130B1756	592 (23.3)	378 (14.9)	245 (9.6)	52 (115)	X3-V3 IP20 if
36	130B1757	592 (23.3)	378 (14.9)	245 (9.6)	53 (117)	X3-V3 IP20 if
48	130B1758	592 (23.3)	378 (14.9)	245 (9.6)	58 (128)	X3-V3 IP20 if
60	130B1759	621 (24.5)	378 (14.9)	338 (13.3)	76 (168)	X4-V3 IP20 if
73	130B1760	621 (24.5)	378 (14.9)	338 (13.3)	98 (216)	X4-V3 IP20 ef
95	130B1761	736 (29)	418 (16.5)	333 (13.1)	104 (229)	X5-V3 IP20 ef
118	130B1762	736 (29)	418 (16.5)	333 (13.1)	106 (234)	X5-V3 IP20 ef
154	130B1763	764 (30.1)	418 (16.5)	405 (15.9)	126 (278)	X6-V3 IP20 ef
183	130B1764	764 (30.1)	418 (16.5)	405 (15.9)	135 (298)	X6-V3 IP20 ef
231	130B1765	957 (37.7)	468 (18.4)	451 (17.8)	172 (379)	X7-V3 IP20 if
291	130B1766	957 (37.7)	468 (18.4)	515 (20.3)	221 (487)	X8-V3 IP20 if
355	130B1768	957 (37.7)	468 (18.4)	515 (20.3)	230 (507)	X8-V3 IP20 ef
380	130B3167	957 (37.7)	468 (18.4)	515 (20.3)	265 (584)	X8-V3 IP20 ef
436	130B1769	957 (37.7)	468 (18.4)	515 (20.3)	272 (600)	X8-V3 IP20 ef

Table 47: AHF 010, 440–480 V, 60 Hz

440–480 V 60 Hz		AHF 010				
Current rating [A]	Code number	Dimensions			Weight [kg (lb)]	Enclosure type
		Height [mm (in)]	Width [mm (in)]	Depth [mm (in)]		
10	130B1482	322 (12.7)	196 (7.7)	205 (8.1)	13.5 (29.8)	X1-V3 IP20 if
14	130B1483	342 (13.5)	196 (7.7)	205 (8.1)	15.2 (33.5)	X1-V3 IP20 ef
19	130B1484	434 (17.1)	238 (9.4)	248 (9.8)	21 (47)	X2-V3 IP20 if
25	130B1485	434 (17.1)	238 (9.4)	248 (9.8)	24 (53)	X2-V3 IP20 if
31	130B1486	592 (23.2)	378 (14.9)	245 (9.6)	33 (73)	X3-V3 IP20 if
36	130B1487	592 (23.2)	378 (14.9)	245 (9.6)	37 (82)	X3-V3 IP20 if
48	130B1488	592 (23.2)	378 (14.9)	245 (9.6)	39 (86)	X3-V3 IP20 if
60	130B1491	621 (24.5)	378 (14.9)	338 (13.3)	44 (97)	X4-V3 IP20 if
73	130B1492	621 (24.5)	378 (14.9)	338 (13.3)	56 (123)	X4-V3 IP20 ef

Table 47: AHF 010, 440–480 V, 60 Hz - (continued)

440–480 V 60 Hz		AHF 010				
Current rating [A]	Code number	Dimensions			Weight [kg (lb)]	Enclosure type
		Height [mm (in)]	Width [mm (in)]	Depth [mm (in)]		
95	130B1493	736 (29)	418 (16.5)	333 (13.1)	62 (137)	X5-V3 IP20 ef
118	130B1494	736 (29)	418 (16.5)	333 (13.1)	74 (164)	X5-V3 IP20 ef
154	130B1495	764 (30.1)	418 (16.5)	405 (15.9)	85 (187)	X6-V3 IP20 if
183	130B1496	764 (30.1)	418 (16.5)	405 (15.9)	102 (225)	X6-V3 IP20 if
231	130B1497	957 (37.7)	468 (18.4)	451 (17.8)	119 (262)	X7-V3 IP20 if
291	130B1498	957 (37.7)	468 (18.4)	451 (17.8)	142 (313)	X7-V3 IP20 if
355	130B1499	957 (37.7)	468 (18.4)	451 (17.8)	163 (359)	X7-V3 IP20 ef
380	130B3165	957 (37.7)	468 (18.4)	451 (17.8)	172 (379)	X7-V3 IP20 ef
436	130B1751	957 (37.7)	468 (18.4)	515 (20.3)	205 (452)	X8-V3 IP20 ef

Table 48: AHF 005, 600 V, 60 Hz

600 V 60 Hz		AHF 005				
Current rating [A]	Code number [P/ N]	Dimensions			Weight [kg (lb)]	Enclosure type
		Height [mm (in)]	Width [mm (in)]	Depth [mm (in)]		
15	130B5246	592 (23.3)	378 (14.9)	245 (9.6)	42 (93)	X3-V3 IP20 if
20	130B5247	592 (23.3)	378 (14.9)	245 (9.6)	50 (110)	X3-V3 IP20 if
24	130B5248	593 (23.4)	378 (14.9)	245 (9.6)	52 (115)	X3-V3 IP20 ef
29	130B5249	621 (24.5)	378 (14.9)	338 (13.3)	75 (165)	X4-V3 IP20 ef
36	130B5250	621 (24.5)	378 (14.9)	338 (13.3)	82 (181)	X4-V3 IP20 ef
50	130B5251	736 (29)	418 (16.5)	333 (13.1)	96 (212)	X5-V3 IP20 ef
58	130B5252	736 (29)	418 (16.5)	333 (13.1)	104 (229)	X5-V3 IP20 ef
77	130B5253	764 (30.1)	418 (16.5)	405 (15.9)	130 (287)	X6-V3 IP20 ef
87	130B5254	764 (30.1)	418 (16.5)	405 (15.9)	135 (298)	X6-V3 IP20 ef
109	130B5255	764 (30.1)	418 (16.5)	405 (15.9)	168 (370)	X6-V3 IP20 ef
128	130B5256	764 (30.1)	418 (16.5)	405 (15.9)	197 (434)	X6-V3 IP20 ef
155	130B5257	957 (37.7)	468 (18.4)	451 (17.8)	220 (485)	X7-V3 IP20 ef
197	130B5258	957 (37.7)	468 (18.4)	451 (17.8)	228 (503)	X7-V3 IP20 ef
240	130B5259	957 (37.7)	468 (18.4)	515 (20.3)	260 (573)	X8-V3 IP20 ef
296	130B5260	957 (37.7)	468 (18.4)	515 (20.3)	297 (655)	X8-V3 IP20 ef
366	–	–	–	–	–	–
395	–	–	–	–	–	–

Table 49: AHF 010, 600 V, 60 Hz

600 V 60 Hz		AHF 010				
Current rating [A]	Code number [P/ N]	Dimensions			Weight [kg (lb)]	Enclosure type
		Height [mm (in)]	Width [mm (in)]	Depth [mm (in)]		
15	130B5212	592 (23.3)	378 (14.9)	245 (9.6)	25 (55)	X3-V3 IP20 if
20	130B5213	592 (23.3)	378 (14.9)	245 (9.6)	36 (79)	X3-V3 IP20 if
24	130B5214	593 (23.4)	378 (14.9)	245 (9.6)	40 (88)	X3-V3 IP20 ef
29	130B5215	621 (24.5)	378 (14.9)	338 (13.3)	42 (93)	X4-V3 IP20 ef
36	130B5216	621 (24.5)	378 (14.9)	338 (13.3)	52 (115)	X4-V3 IP20 ef
50	130B5217	736 (29)	418 (16.5)	333 (13.1)	56 (123)	X5-V3 IP20 ef
58	130B5218	736 (29)	418 (16.5)	333 (13.1)	62 (137)	X5-V3 IP20 ef
77	130B5219	764 (30.1)	418 (16.5)	405 (15.9)	74 (163)	X6-V3 IP20 ef
87	130B5220	764 (30.1)	418 (16.5)	405 (15.9)	85 (187)	X6-V3 IP20 ef
109	130B5221	764 (30.1)	418 (16.5)	405 (15.9)	105 (231)	X6-V3 IP20 ef
128	130B5222	764 (30.1)	418 (16.5)	405 (15.9)	123 (271)	X6-V3 IP20 ef
155	130B5223	957 (37.7)	468 (18.4)	451 (17.8)	136 (399)	X7-V3 IP20 ef
197	130B5224	957 (37.7)	468 (18.4)	451 (17.8)	142 (313)	X7-V3 IP20 ef
240	130B5225	957 (37.7)	468 (18.4)	451 (17.8)	163 (359)	X7-V3 IP20 ef
296	130B5226	957 (37.7)	468 (18.4)	515 (20.3)	205 (452)	X8-V3 IP20 ef
366	130B5227	957 (37.7)	468 (18.4)	515 (20.3)	228 (503)	X8-V3 IP20 ef
395	130B5228	957 (37.7)	468 (18.4)	515 (20.3)	260 (573)	X8-V3 IP20 ef

Table 50: AHF 005, 500–690 V, 50 Hz

500–690 V 50 Hz		AHF 005				
Current rating [A]	Code number [P/ N]	Dimensions			Weight [kg (lb)]	Enclosure type
		Height [mm (in)]	Width [mm (in)]	Depth [mm (in)]		
15	130B5088	592 (23.3)	378 (14.9)	245 (9.6)	42 (93)	X3-V3 IP20 if
20	130B5089	592 (23.3)	378 (14.9)	245 (9.6)	50 (110)	X3-V3 IP20 if
24	130B5090	593 (23.4)	378 (14.9)	245 (9.6)	52 (115)	X3-V3 IP20 ef
29	130B5092	621 (24.5)	378 (14.9)	338 (13.3)	75 (165)	X4-V3 IP20 ef
36	130B5125	621 (24.5)	378 (14.9)	338 (13.3)	82 (181)	X4-V3 IP20 ef
50	130B5144	736 (29)	418 (16.5)	333 (13.1)	96 (212)	X5-V3 IP20 ef
58	130B5168	736 (29)	418 (16.5)	333 (13.1)	104 (229)	X5-V3 IP20 ef
77	130B5169	764 (30.1)	418 (16.5)	405 (15.9)	130 (287)	X6-V3 IP20 ef
87	130B5170	764 (30.1)	418 (16.5)	405 (15.9)	135 (298)	X6-V3 IP20 ef
109	130B5172	764 (30.1)	418 (16.5)	405 (15.9)	168 (370)	X6-V3 IP20 ef

Table 50: AHF 005, 500–690 V, 50 Hz - (continued)

500–690 V 50 Hz		AHF 005				
Current rating [A]	Code number [P/ N]	Dimensions			Weight [kg (lb)]	Enclosure type
		Height [mm (in)]	Width [mm (in)]	Depth [mm (in)]		
128	130B5195	764 (30.1)	418 (16.5)	405 (15.9)	197 (434)	X6-V3 IP20 ef
155	130B5196	957 (37.7)	468 (18.4)	451 (17.8)	220 (485)	X7-V3 IP20 ef
197	130B5197	957 (37.7)	468 (18.4)	451 (17.8)	228 (503)	X7-V3 IP20 ef
240	130B5198	957 (37.7)	468 (18.4)	515 (20.3)	261 (575)	X8-V3 IP20 ef
296	130B5199	957 (37.7)	468 (18.4)	515 (20.3)	297 (655)	X8-V3 IP20 ef
366	–	–	–	–	–	–
395	–	–	–	–	–	–

Table 51: AHF 010, 500–690 V, 50 Hz

500–690 V 50 Hz		AHF 010				
Current rating [A]	Code number [P/ N]	Dimensions			Weight [kg (lb)]	Enclosure type
		Height [mm (in)]	Width [mm (in)]	Depth [mm (in)]		
15	130B5280	592 (23.3)	378 (14.9)	245 (9.6)	25 (55)	X3-V3 IP20 if
20	130B5281	592 (23.3)	378 (14.9)	245 (9.6)	36 (79)	X3-V3 IP20 if
24	130B5282	593 (23.4)	378 (14.9)	245 (9.6)	40 (88)	X3-V3 IP20 ef
29	130B5283	621 (24.5)	378 (14.9)	338 (13.3)	42 (93)	X4-V3 IP20 ef
36	130B5284	621 (24.5)	378 (14.9)	338 (13.3)	52 (115)	X4-V3 IP20 ef
50	130B5285	736 (29)	418 (16.5)	333 (13.1)	56 (123)	X5-V3 IP20 ef
58	130B5286	736 (29)	418 (16.5)	333 (13.1)	62 (137)	X5-V3 IP20 ef
77	130B5287	764 (30.1)	418 (16.5)	405 (15.9)	74 (163)	X6-V3 IP20 ef
87	130B5288	764 (30.1)	418 (16.5)	405 (15.9)	85 (187)	X6-V3 IP20 ef
109	130B5289	764 (30.1)	418 (16.5)	405 (15.9)	105 (231)	X6-V3 IP20 ef
128	130B5290	764 (30.1)	418 (16.5)	405 (15.9)	123 (271)	X6-V3 IP20 ef
155	130B5291	957 (37.7)	468 (18.4)	451 (17.8)	136 (300)	X7-V3 IP20 ef
197	130B5292	957 (37.7)	468 (18.4)	451 (17.8)	142 (313)	X7-V3 IP20 ef
240	130B5293	957 (37.7)	468 (18.4)	451 (17.8)	163 (359)	X7-V3 IP20 ef
296	130B5294	957 (37.7)	468 (18.4)	515 (20.3)	205 (452)	X8-V3 IP20 ef
366	130B5295	957 (37.7)	468 (18.4)	515 (20.3)	228 (503)	X8-V3 IP20 ef
395	130B5296	957 (37.7)	468 (18.4)	515 (20.3)	261 (575)	X8-V3 IP20 ef

7.4.2 Terminal Specifications

The terminal specification tables show terminal types, cable cross-section, tightening torque, and more for the AHF filters.

NOTICE

The maximum cable cross-section mentioned in the tables [Table 52](#) to [Table 56](#) are for solid cables. The maximum cross-sections for multi-core cables can be seen in the terminal specifications on the illustrations in [7.4.3 IP20 Enclosures](#).

Table 52: Terminal Specifications, 380–415 V, 50 Hz

AHF terminal connections													
380–415 V, 50 Hz		Enclosure size type	Terminals X1 and X2			Terminals X3 and X4			Terminals A and B			PE	
AHF 005 [A]	AHF 010 [A]		Cable cross-sections [mm ² (AWG/MCM)]	Termination	Torque [Nm (In-lb)]	Cable cross-sections [mm ² (AWG/MCM)]	Termination	Torque [Nm (In-lb)]	Cable cross-sections [mm ² (AWG/MCM)]	Termination	Torque [Nm (In-lb)]	Type	Torque [Nm (In-lb)]
10 14	10 14	X1	0.5–10 (20–8)	Cable and sleeve	1.6 (14.2) ±10%	0.5–4.0 (20–12)	Cable and sleeve	0.8 (7.1) ±10%	0.5–4.0 (20–12)	Cable and sleeve	0.8 (7.1) ±10%	M6	4.5 (40) ±10%
22 29	22 29	X2	1.5–16 (16–6)	Cable and sleeve	2.4 (21.2) ±10%	0.5–4.0 (20–12)	Cable and sleeve	0.8 (7.1) ±10%	0.5–4.0 (20–12)	Cable and sleeve	0.8 (7.1) ±10%	M6	4.5 (40) ±10%
34 40 55	34 40 55	X3	1.5–25 16–4	Cable and sleeve	3.5 (31) ±10%	1.5–16 (16–6)	Cable and sleeve	2.4 (21.2) ±10%	0.5–4.0 (20–12)	Cable and sleeve	0.8 (7.1) ±10%	M8	10 (88.5) ±10%
66 82	66 82	X4	1.5–50 (16–1-1/10)	Cable and sleeve	4 (35.4) ±10%	1.5–25 16–4	Cable and sleeve	3.5 (31) ±10%	0.5–4.0 (20–12)	Cable and sleeve	0.8 (7.1) ±10%	M8	10 (88.5) ±10%
96 133	96 133	X5	10–70 (8–2/0)	Cable and sleeve	5 (44.3) ±10%	1.5–50 (16–4)	Cable and sleeve	3.5 (31) ±10%	0.5–4.0 (20–12)	Cable and sleeve	0.8 (7.1) ±10%	M8	10 (88.5) ±10%
171 204	171 204	X6	2.5–95 (14–3/0)	Cable lug M8	10 (88.5) ±10%	1.5–50 (16–1-1/0)	Cable and sleeve	4.0 (35.4) ±10%	0.5–4.0 (20–12)	Cable and sleeve	0.8 (7.1) ±10%	M8	10 (88.5) ±10%
251 304	251 304 325 381	X7	25–300 (4–600)	Cable lug M16	50 (442.5) ±10%	16–150 (6–300)	Cable and sleeve	18 (159.3) ±10%	0.5–4.0 (20–12)	Cable and sleeve	0.8 (7.1) ±10%	M12	40 (354) ±10%
325 381 480	480	X8	25–300 (4–600)	Cable lug M16	50 (442.5) ±10%	16–150 (6–300)	Cable and sleeve	18 (159.3) ±10%	0.5–4.0 (20–12)	Cable and sleeve	0.8 (7.1) ±10%	M12	40 (354) ±10%

Table 53: Terminal Specifications, 380–415 V, 60 Hz

AHF terminal connections													
380–415 V, 60 Hz		Enclosure size type	Terminals X1 and X2			Terminals X3 and X4			Terminals A and B			PE	
AHF 005 [A]	AHF 010 [A]		Cable cross-sections [mm ² (AWG/MCM)]	Termination	Torque [Nm (In-lb)]	Cable cross-sections [mm ² (AWG/MCM)]	Termination	Torque [Nm (In-lb)]	Cable cross-sections [mm ² (AWG/MCM)]	Termination	Torque [Nm (In-lb)]	Type	Torque [Nm (In-lb)]
10 14	10 14	X1	0.5–10 (20–8)	Cable and sleeve	1.6 (14.2) ±10%	0.5–4.0 (20–12)	Cable and sleeve	0.8 (7.1) ±10%	0.5–4.0 (20–12)	Cable and sleeve	0.8 (7.1) ±10%	M6	4.5 (40) ±10%
22 29	22 29	X2	1.5–16 (16–6)	Cable and sleeve	2.4 (21.2) ±10%	0.5–4.0 (20–12)	Cable and sleeve	0.8 (7.1) ±10%	0.5–4.0 (20–12)	Cable and sleeve	0.8 (7.1) ±10%	M6	4.5 (40) ±10%
34 40 55	34 40 55	X3	1.5–25 16–4	Cable and sleeve	3.5 (31) ±10%	1.5–16 (16–6)	Cable and sleeve	2.4 (21.2) ±10%	0.5–4.0 (20–12)	Cable and sleeve	0.8 (7.1) ±10%	M8	10 (88.5) ±10%
66 82	66 82	X4	1.5–50 (16–1-1/10)	Cable and sleeve	4.0 (35.4) ±10%	1.5–25 16–4	Cable and sleeve	3.5 (31) ±10%	0.5–4.0 (20–12)	Cable and sleeve	0.8 (7.1) ±10%	M8	10 (88.5) ±10%
96 133	96 133	X5	10–70 (8–2/0)	Cable and sleeve	5.0 (44.3) ±10%	1.5–25 (16–4)	Cable and sleeve	3.5 (31) ±10%	0.5–4.0 (20–12)	Cable and sleeve	0.8 (7.1) ±10%	M8	10 (88.5) ±10%
171 204	171 204	X6	2.5–95 (14–3/0)	Cable lug M8	10 (88.5) ±10%	1.5–50 (16–1-1/0)	Cable and sleeve	4.0 (35.4) ±10%	0.5–4.0 (20–12)	Cable and sleeve	0.8 (7.1) ±10%	M8	10 (88.5) ±10%
251	251 304 325 381	X7	25–300 (4–600)	Cable lug M16	50 (442.5) ±10%	16–150 (6–300)	Cable and sleeve	18 (159.3) ±10%	0.5–4.0 (20–12)	Cable and sleeve	0.8 (7.1) ±10%	M12	40 (354) ±10%
304 325 381 480	480	X8	25–300 (4–600)	Cable lug M16	50 (442.5) ±10%	16–150 (6–300)	Cable and sleeve	18 (159.3) ±10%	0.5–4.0 (20–12)	Cable and sleeve	0.8 (7.1) ±10%	M12	40 (354) ±10%

Table 54: Terminal Specifications, 480–480 V, 60 Hz

AHF terminal connections													
480–480 V, 60 Hz		Enclosure size type	Terminals X1 and X2			Terminals X3 and X4			Terminals A and B			PE	
AHF 005 [A]	AHF 010 [A]		Cable cross-sections [mm ² (AWG/MCM)]	Termination	Torque [Nm (In-lb)]	Cable cross-sections [mm ² (AWG/MCM)]	Termination	Torque [Nm (In-lb)]	Cable cross-sections [mm ² (AWG/MCM)]	Termination	Torque [Nm (In-lb)]	Type	Torque [Nm (In-lb)]
10 14	10 14	X1	0.5–10 (20–8)	Cable and sleeve	1.6 (14.2) ±10%	0.5–4.0 (20–12)	Cable and sleeve	0.8 (7.1) ±10%	0.5–4.0 (20–12)	Cable and sleeve	0.8 (7.1) ±10%	M6	4.5 (40) ±10%
19 25	19 25	X2	1.5–16 (16–6)	Cable and sleeve	2.4 (21.2) ±10%	0.5–4.0 (20–12)	Cable and sleeve	0.8 (7.1) ±10%	0.5–4.0 (20–12)	Cable and sleeve	0.8 (7.1) ±10%	M6	4.5 (40) ±10%
31 36 48	31 36 48	X3	1.5–25 16–4	Cable and sleeve	3.5 (31) ±10%	1.5–16 (16–6)	Cable and sleeve	2.4 (21.2) ±10%	0.5–4.0 (20–12)	Cable and sleeve	0.8 (7.1) ±10%	M8	10 (88.5) ±10%
60 73	60 73	X4	1.5–50 (16–1-1/10)	Cable and sleeve	4.0 (35.4) ±10%	1.5–25 16–4	Cable and sleeve	3.5 (31) ±10%	0.5–4.0 (20–12)	Cable and sleeve	0.8 (7.1) ±10%	M8	10 (88.5) ±10%
95 118	95 118	X5	10–70 (8–2/0)	Cable and sleeve	5.0 (44.3) ±10%	1.5–25 (16–4)	Cable and sleeve	3.5 (31) ±10%	0.5–4.0 (20–12)	Cable and sleeve	0.8 (7.1) ±10%	M8	10 (88.5) ±10%
154 183	154 183	X6	2.5–95 (14–3/0)	Cable lug M8	10 (88.5) ±10%	1.5–50 (16–1-1/0)	Cable and sleeve	4.0 (35.4) ±10%	0.5–4.0 (20–12)	Cable and sleeve	0.8 (7.1) ±10%	M8	10 (88.5) ±10%
231 291 355 380	231 291 355 380	X7	25–300 (4–600)	Cable lug M16	50 (442.5) ±10%	16–150 (6–300)	Cable and sleeve	18 (159.3) ±10%	0.5–4.0 (20–12)	Cable and sleeve	0.8 (7.1) ±10%	M12	40 (354) ±10%
291 355 380 436	436	X8	25–300 (4–600)	Cable lug M16	50 (442.5) ±10%	16–150 (6–300)	Cable and sleeve	18 (159.3) ±10%	0.5–4.0 (20–12)	Cable and sleeve	0.8 (7.1) ±10%	M12	40 (354) ±10%

Table 55: Terminal Specifications, 600 V, 60 Hz

AHF terminal connections													
600V, 60 Hz		Enclosure size type	Terminals X1 and X2			Terminals X3 and X4			Terminals A and B			PE	
AHF 005 [A]	AHF 010 [A]		Cable cross-sections [mm ² (AWG/MCM)]	Termination	Torque [Nm (In-lb)]	Cable cross-sections [mm ² (AWG/MCM)]	Termination	Torque [Nm (In-lb)]	Cable cross-sections [mm ² (AWG/MCM)]	Termination	Torque [Nm (In-lb)]	Type	Torque [Nm (In-lb)]
15 20 24	15 20 24	X3	1.5–25 16–4	Cable and sleeve	3.5 (31) ±10%	1.5–16 (16–6)	Cable and sleeve	2.4 (21.2) ±10%	0.5–4.0 (20–12)	Cable and sleeve	0.8 (7.1) ±10%	M8	10 (88.5) ±10%
29 36	29 36	X4	1.5–50 (16–1-1/0)	Cable and sleeve	4.0 (35.4) ±10%	1.5–25 16–4	Cable and sleeve	3.5 (31) ±10%	0.5–4.0 (20–12)	Cable and sleeve	0.8 (7.1) ±10%	M8	10 (88.5) ±10%
50 58	50 58	X5	10–70 (8–2/0)	Cable and sleeve	5.0 (44.3) ±10%	1.5–25 (16–4)	Cable and sleeve	3.5 (31) ±10%	0.5–4.0 (20–12)	Cable and sleeve	0.8 (7.1) ±10%	M8	10 (88.5) ±10%
77 87 109 128	77 87 109 128	X6	2.5–95 (14–3/0)	Cable lug M8	10 (88.5) ±10%	1.5–50 (16–1-1/0)	Cable and sleeve	4.0 (35.4) ±10%	0.5–4.0 (20–12)	Cable and sleeve	0.8 (7.1) ±10%	M8	10 (88.5) ±10%
155 197 240	155 197 240	X7	25–300 (4–600)	Cable lug M16	50 (442.5) ±10%	16–150 (6–300)	Cable and sleeve	18 (159.3) ±10%	0.5–4.0 (20–12)	Cable and sleeve	0.8 (7.1) ±10%	M12	40 (354) ±10%
240 296	296 366 395	X8	25–300 (4–600)	Cable lug M16	50 (442.5) ±10%	16–150 (6–300)	Cable and sleeve	18 (159.3) ±10%	0.5–4.0 (20–12)	Cable and sleeve	0.8 (7.1) ±10%	M12	40 (354) ±10%

Table 56: Terminal Specifications, 500–690 V, 50 Hz

AHF terminal connections													
500–690 V, 50 Hz		Enclosure size type	Terminals X1 and X2			Terminals X3 and X4			Terminals A and B			PE	
AHF 005 [A]	AHF 010 [A]		Cable cross-sections [mm ² (AWG/MCM)]	Termination	Torque [Nm (In-lb)]	Cable cross-sections [mm ² (AWG/MCM)]	Termination	Torque [Nm (In-lb)]	Cable cross-sections [mm ² (AWG/MCM)]	Termination	Torque [Nm (In-lb)]	Type	Torque [Nm (In-lb)]
15 20 24	15 20 24	X3	1.5–25 16–4	Cable and sleeve	3.5 (31) ±10%	1.5–16 (16–6)	Cable and sleeve	2.4 (21.2) ±10%	0.5–4.0 (20–12)	Cable and sleeve	0.8 (7.1) ±10%	M8	10 (88.5) ±10%
29 36	29 36	X4	1.5–50 (16–1-1/0)	Cable and sleeve	4.0 (35.4) ±10%	1.5–25 16–4	Cable and sleeve	3.5 (31) ±10%	0.5–4.0 (20–12)	Cable and sleeve	0.8 (7.1) ±10%	M8	10 (88.5) ±10%
50 58	50 58	X5	10–70 (8–2/0)	Cable and sleeve	5.0 (44.3) ±10%	1.5–25 (16–4)	Cable and sleeve	3.5 (31) ±10%	0.5–4.0 (20–12)	Cable and sleeve	0.8 (7.1) ±10%	M8	10 (88.5) ±10%
77 87 109 128	77 87 109 128	X6	2.5–95 (14–3/0)	Cable lug M8	10 (88.5) ±10%	1.5–50 (16–1-1/0)	Cable and sleeve	4.0 (35.4) ±10%	0.5–4.0 (20–12)	Cable and sleeve	0.8 (7.1) ±10%	M8	10 (88.5) ±10%
155 197 240	155 197 240	X7	25–300 (4–600)	Cable lug M16	50 (442.5) ±10%	16–150 (6–300)	Cable and sleeve	18 (159.3) ±10%	0.5–4.0 (20–12)	Cable and sleeve	0.8 (7.1) ±10%	M12	40 (354) ±10%
240 296	296 366 395	X8	25–300 (4–600)	Cable lug M16	50 (442.5) ±10%	16–150 (6–300)	Cable and sleeve	18 (159.3) ±10%	0.5–4.0 (20–12)	Cable and sleeve	0.8 (7.1) ±10%	M12	40 (354) ±10%

7.4.3 IP20 Enclosures

Mechanical drawings in 2D PDF, 2D DWG, and 3D STEP can be downloaded from danfoss.com.

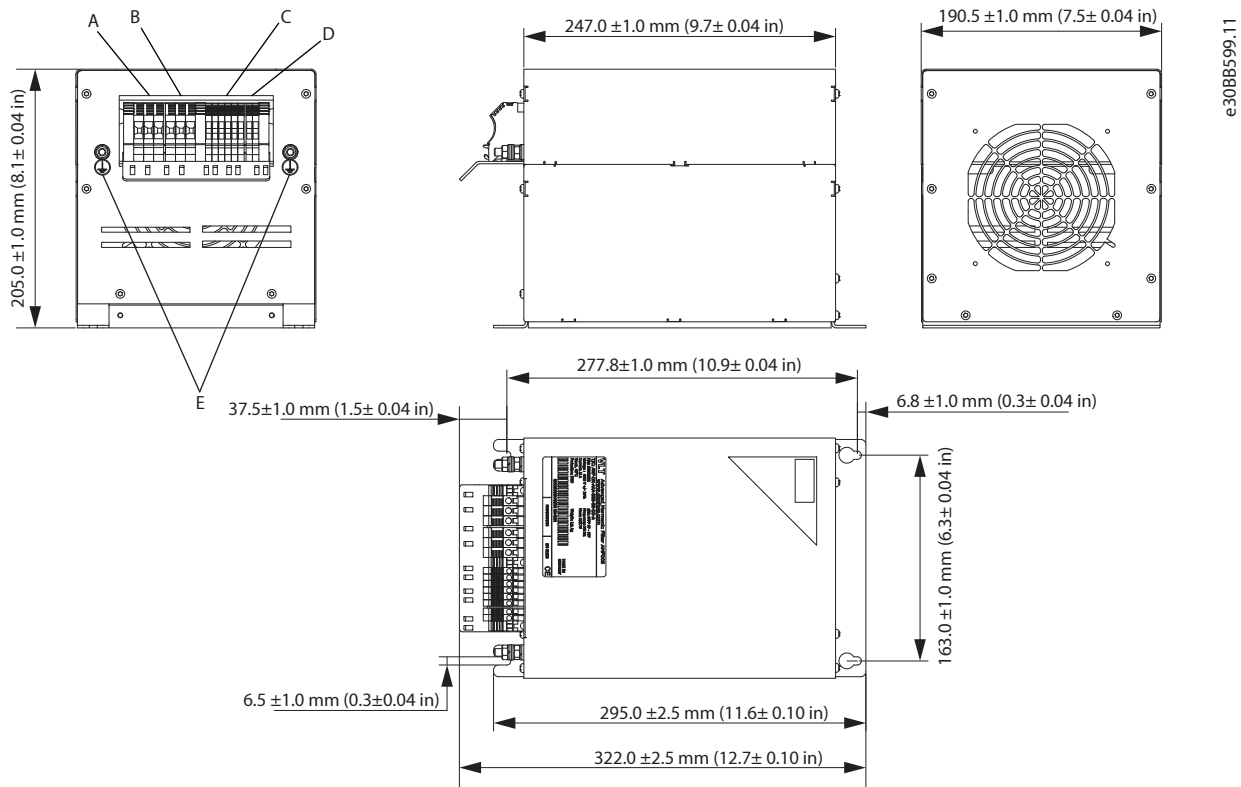

e30BB599.11

Figure 31: IP20 X1-V3 Internal Fan

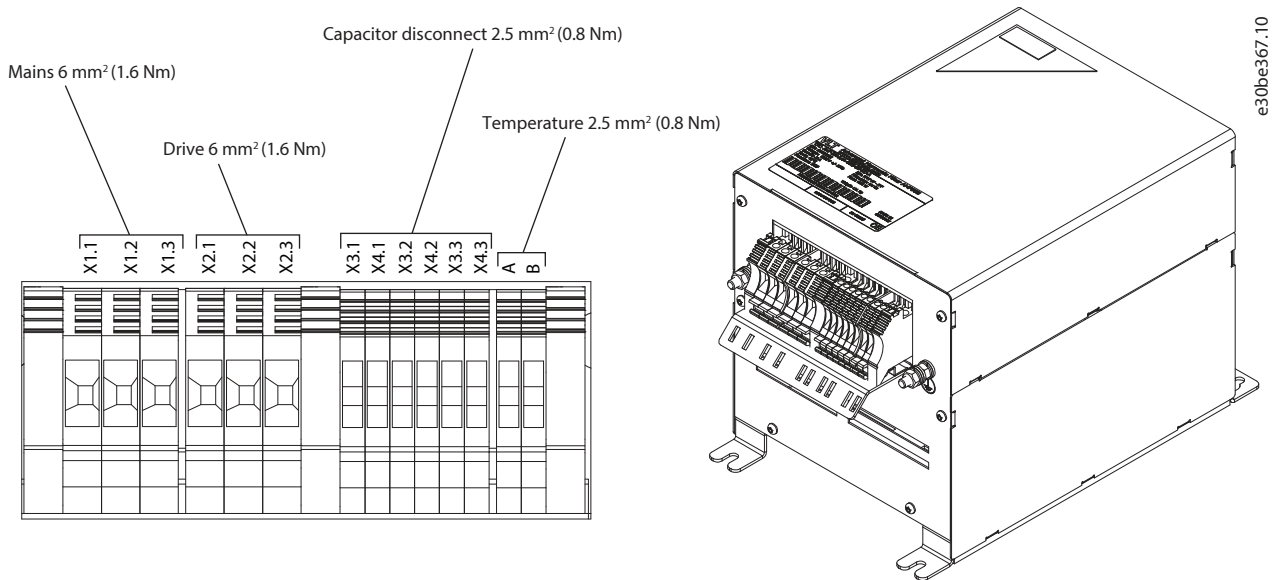

e30be367.10

Figure 32: IP20 X1-V3 Internal Fan, Terminal Designation and 3D View

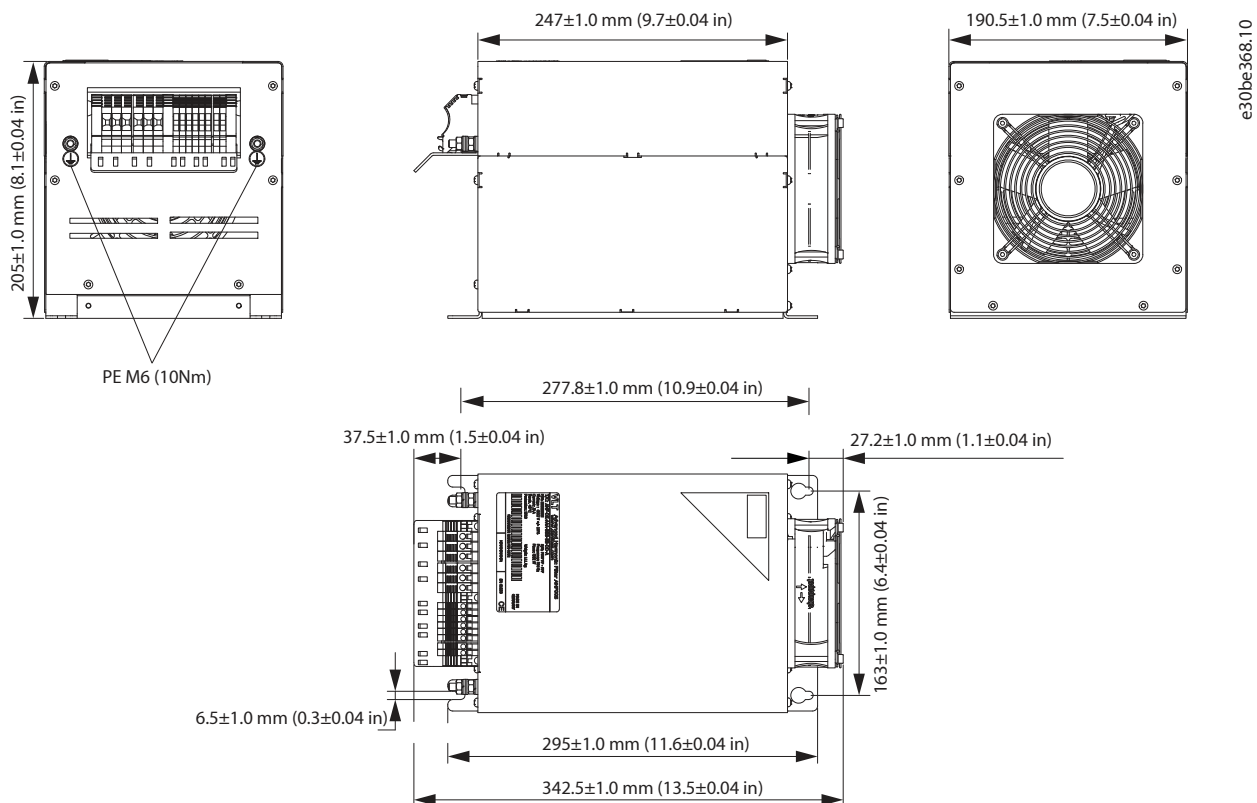

Figure 33: IP20 X1-V3 External Fan

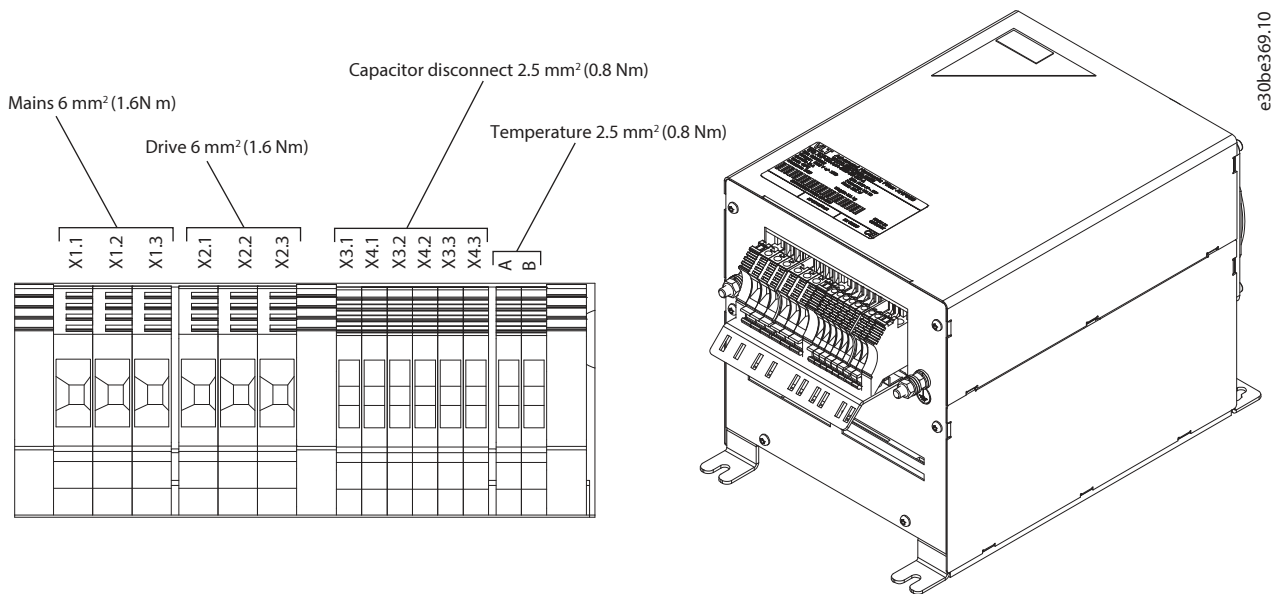
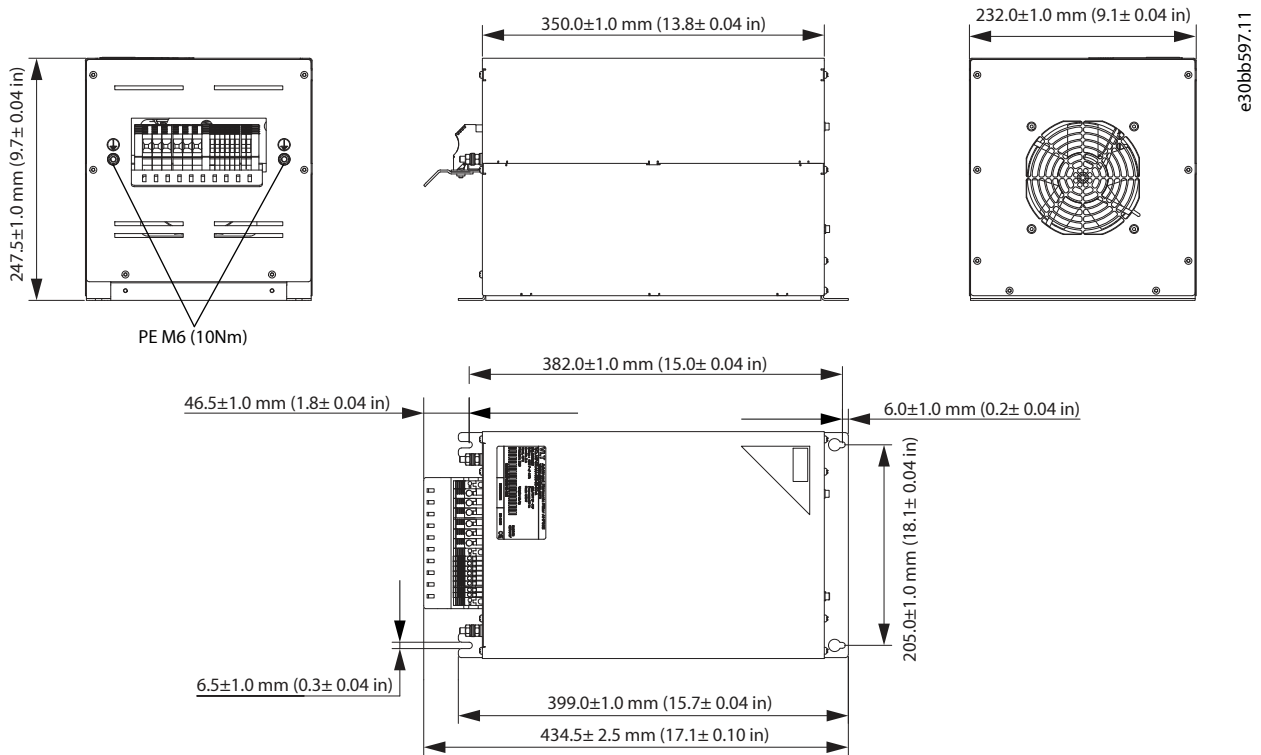
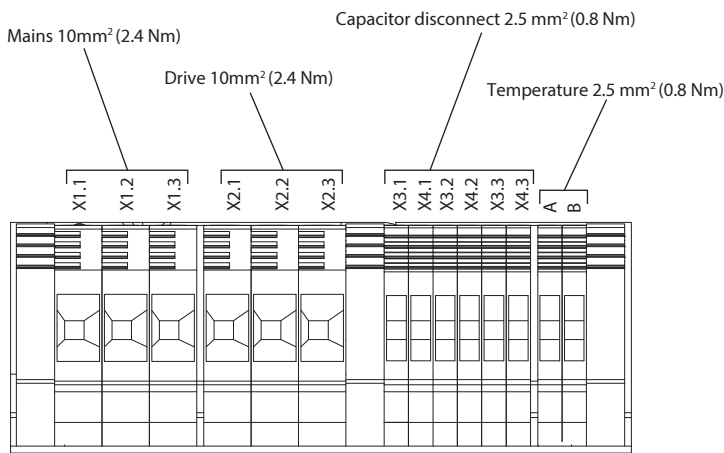

Figure 34: IP20 X1-V3 External Fan, Terminal Designation and 3D View



e30bb597.11

Figure 35: IP20 X2-V3 Internal Fan



e30be370.10

Figure 36: IP20 X2-V3 Internal Fan, Terminal Designation and 3D View

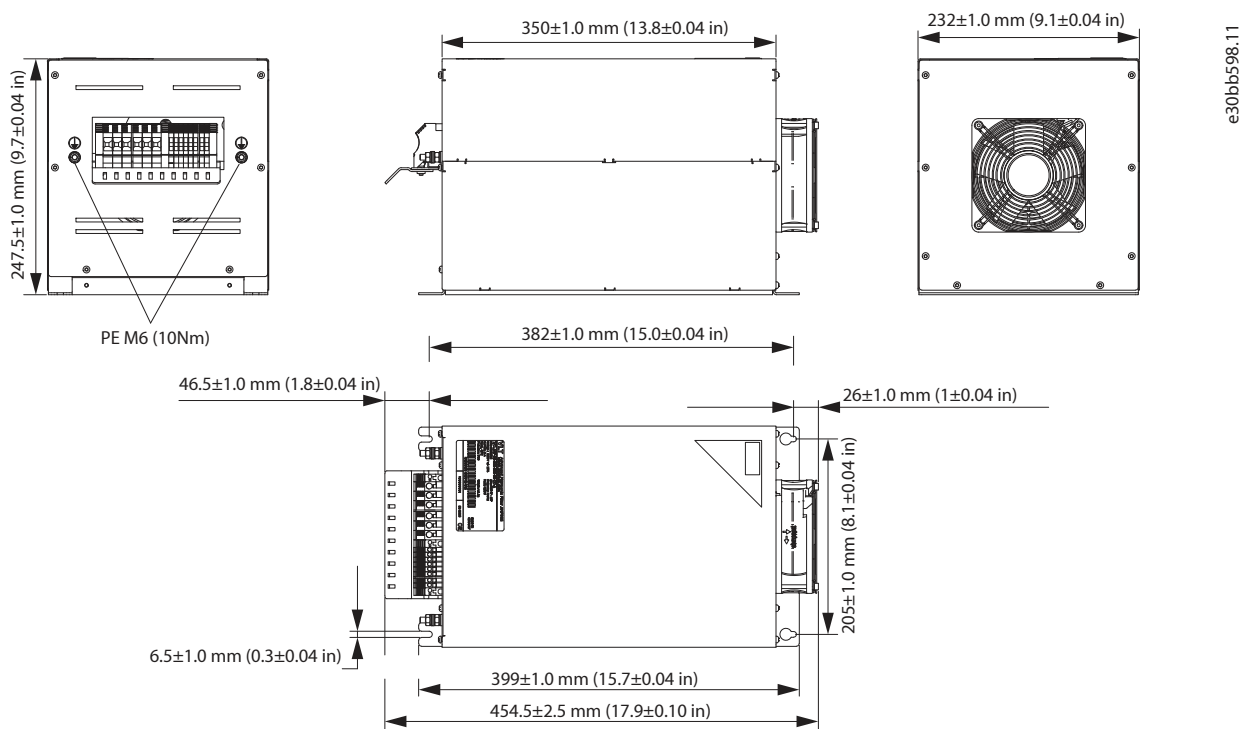

Figure 37: IP20 X2-V3 External Fan

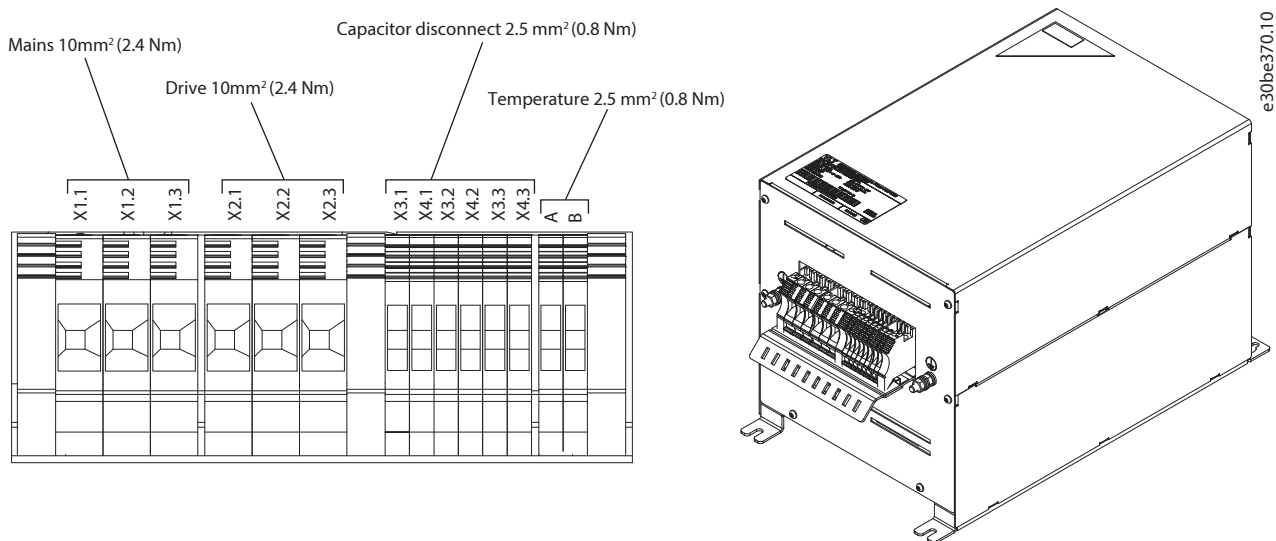

Figure 38: IP20 X2-V3 External Fan, Terminal Designation and 3D View

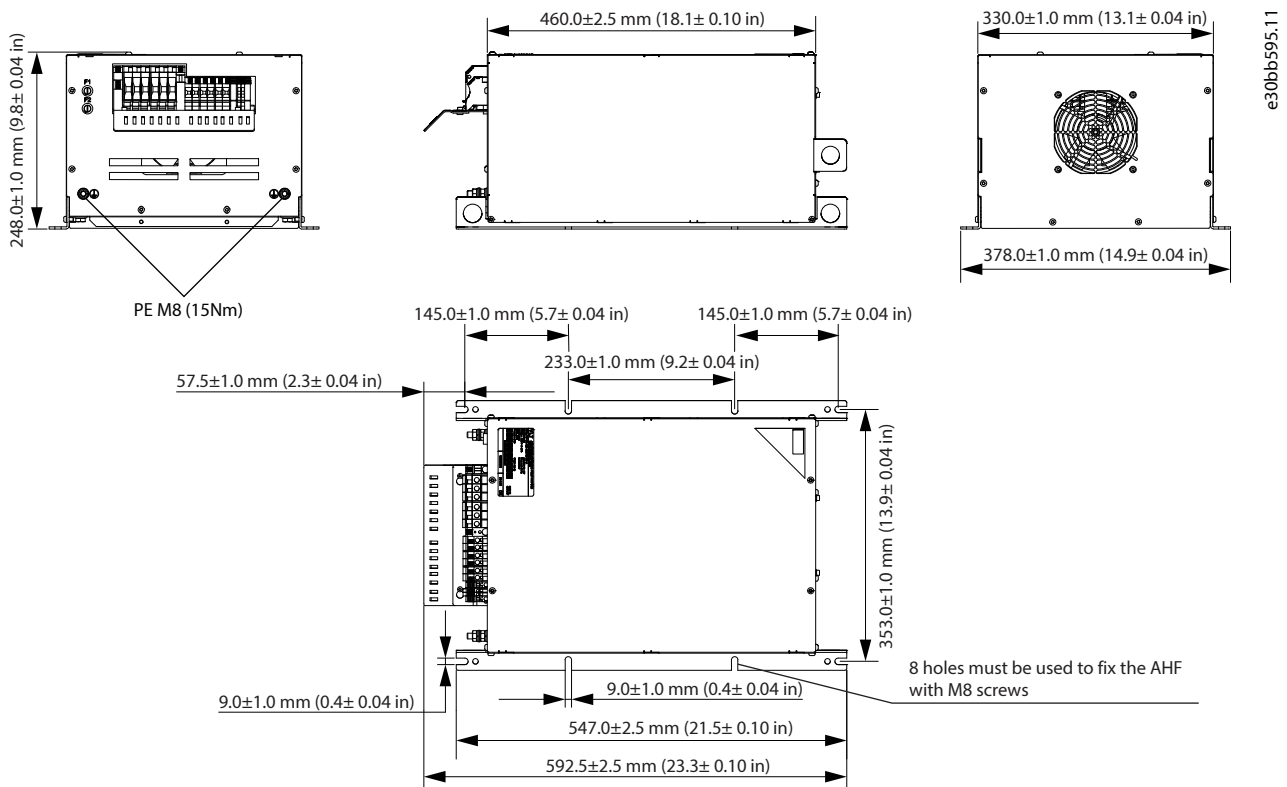

Figure 39: IP20 X3-V3 Internal Fan

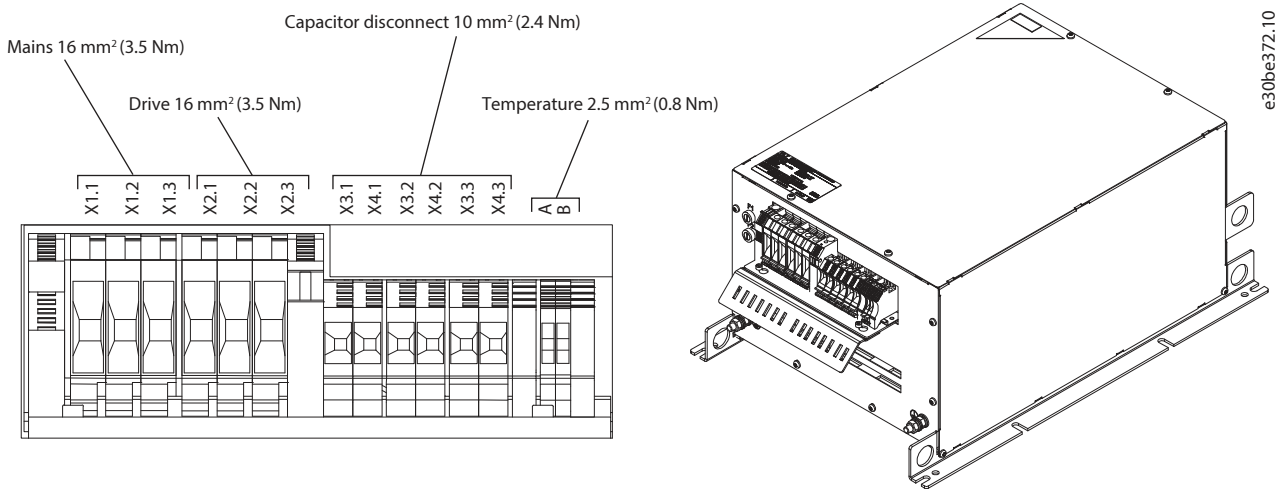

Figure 40: IP20 X3-V3 Internal Fan, Terminal Designation and 3D View

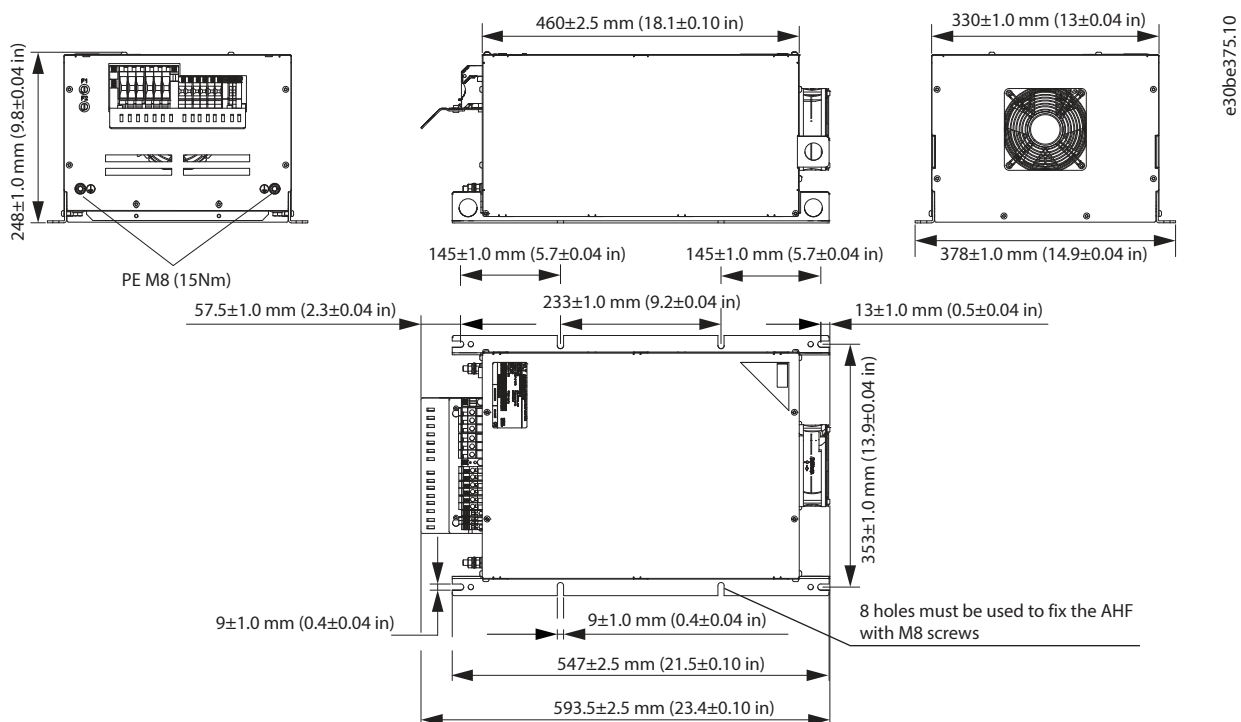

Figure 41: IP20 X3-V3 External Fan

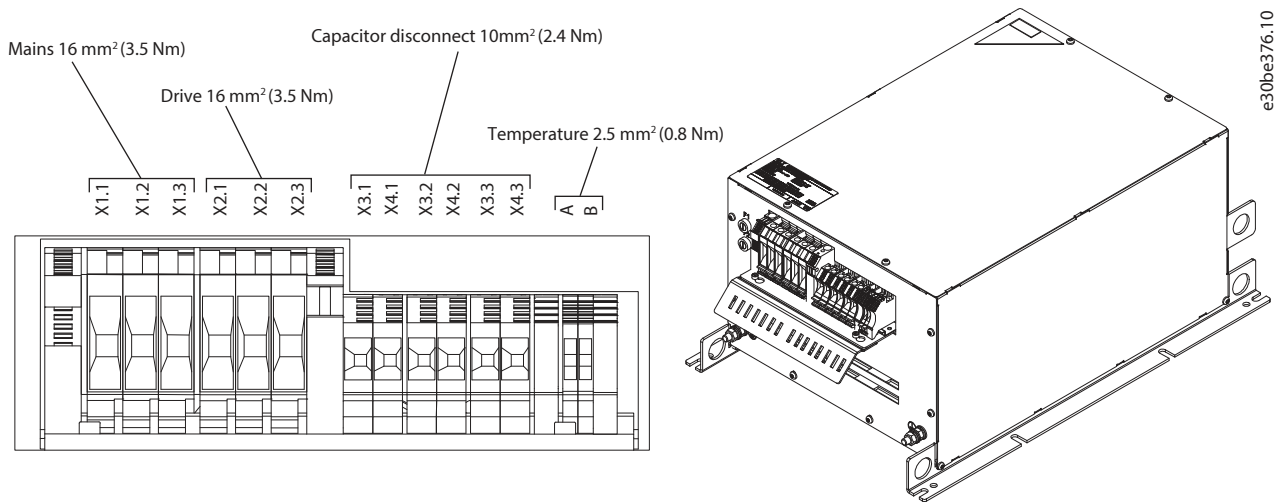

Figure 42: IP20 X3-V3 External Fan, Terminal Designation and 3D View

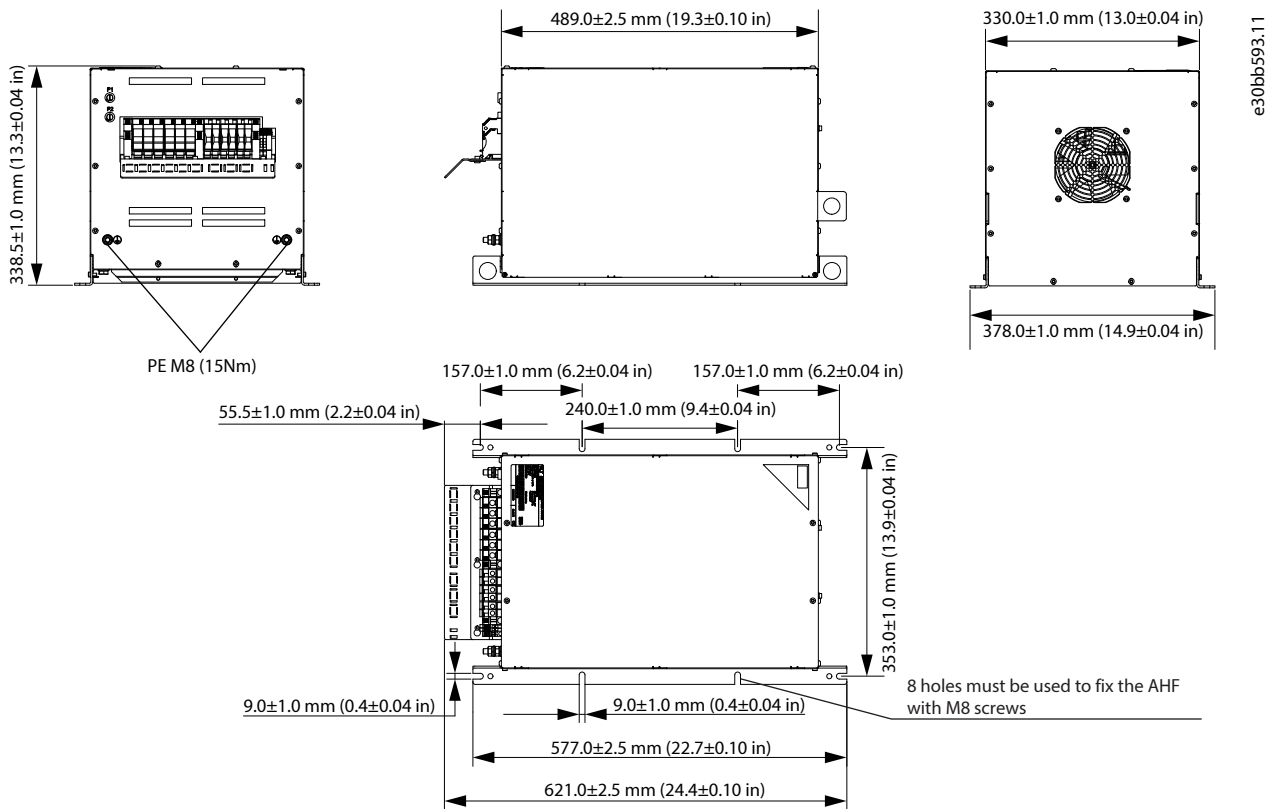

Figure 43: IP20 X4-V3 Internal Fan

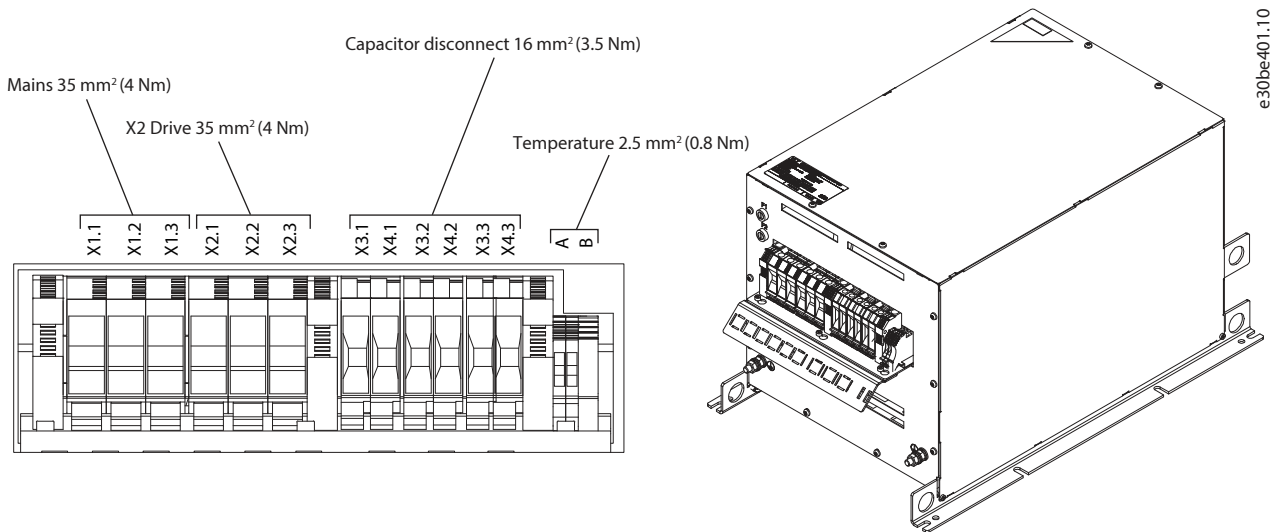

Figure 44: IP20 X4-V3 Internal Fan, Terminal Designation and 3D View

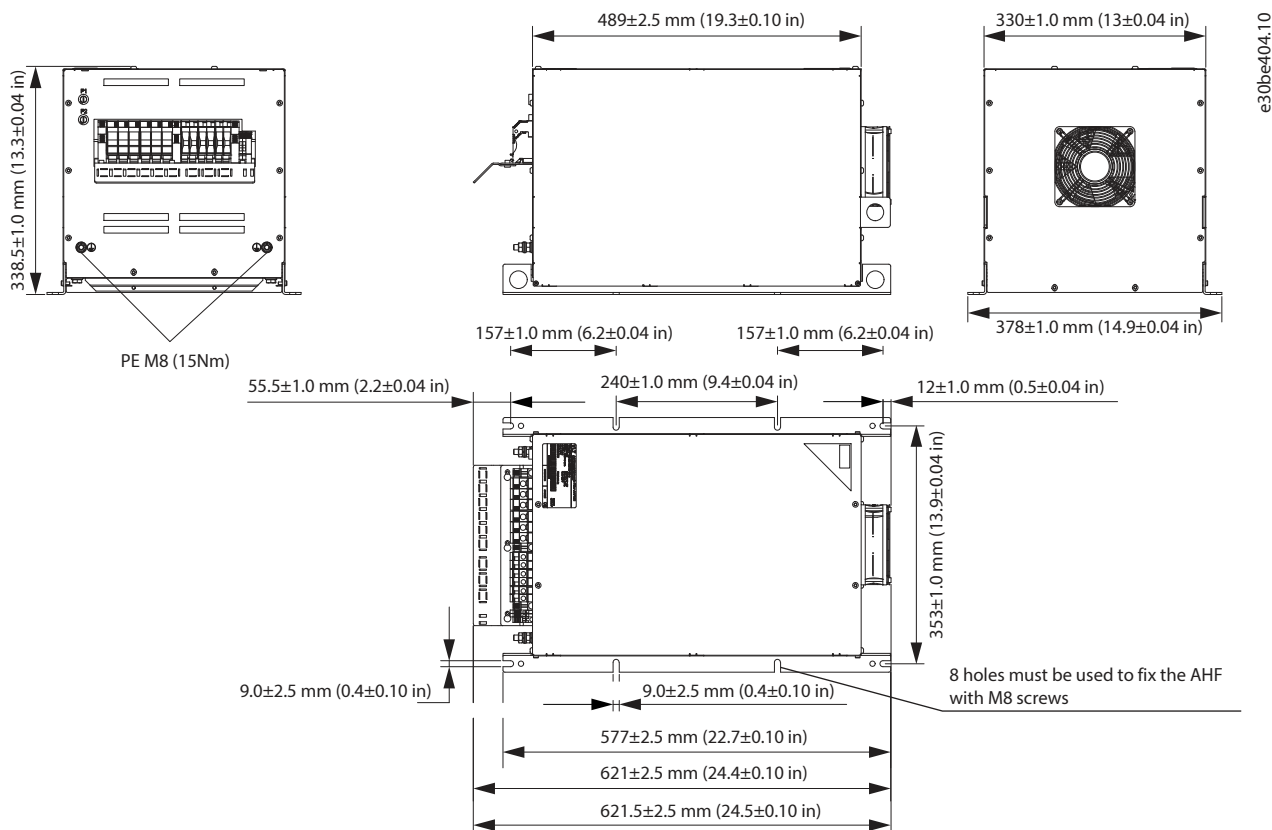

Figure 45: IP20 X4-V3 External Fan

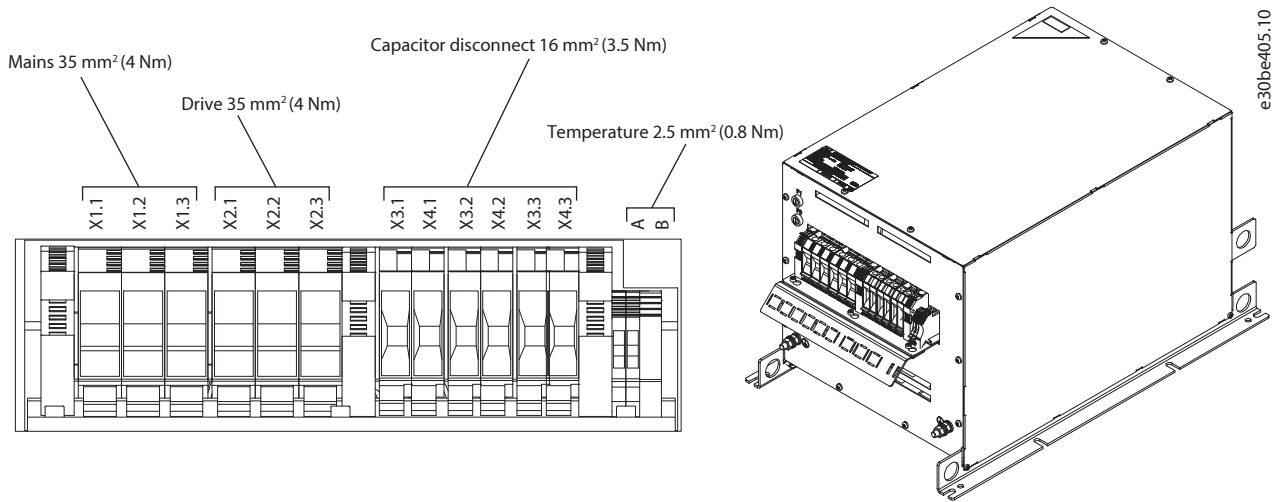

Figure 46: IP20 X4-V3 External Fan, Terminal Designation and 3D View

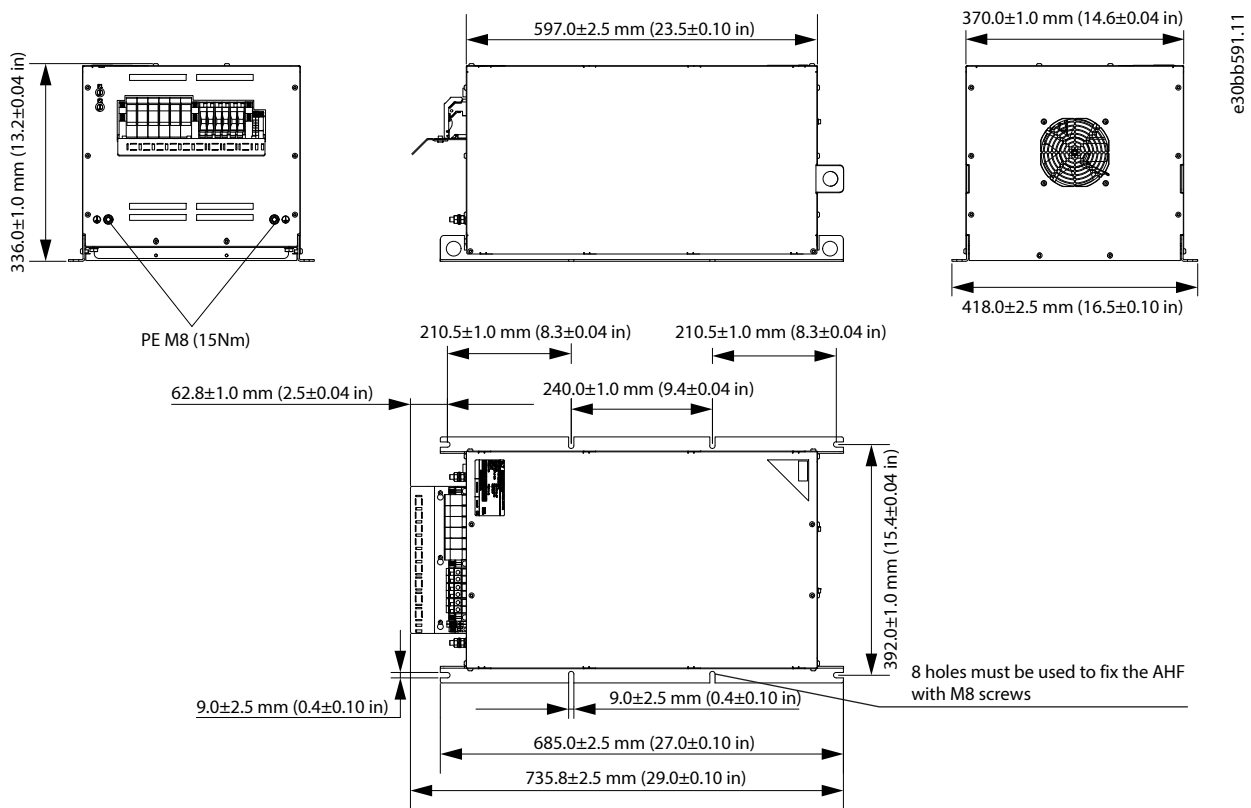

Figure 47: IP20 X5-V3 Internal Fan

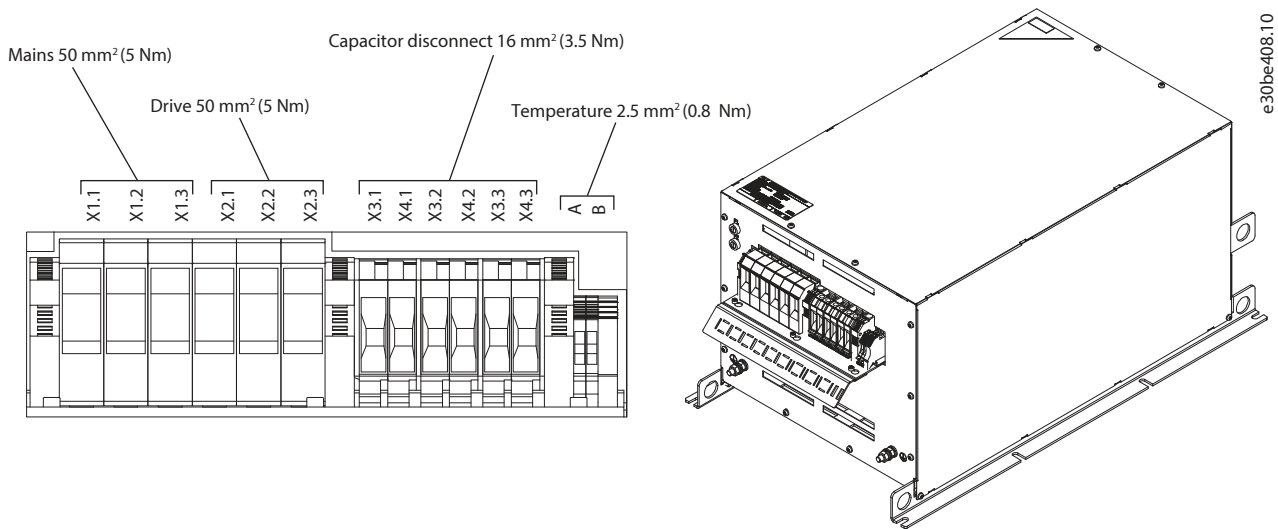

Figure 48: IP20 X5-V3 Internal Fan, Terminal Designation and 3D View

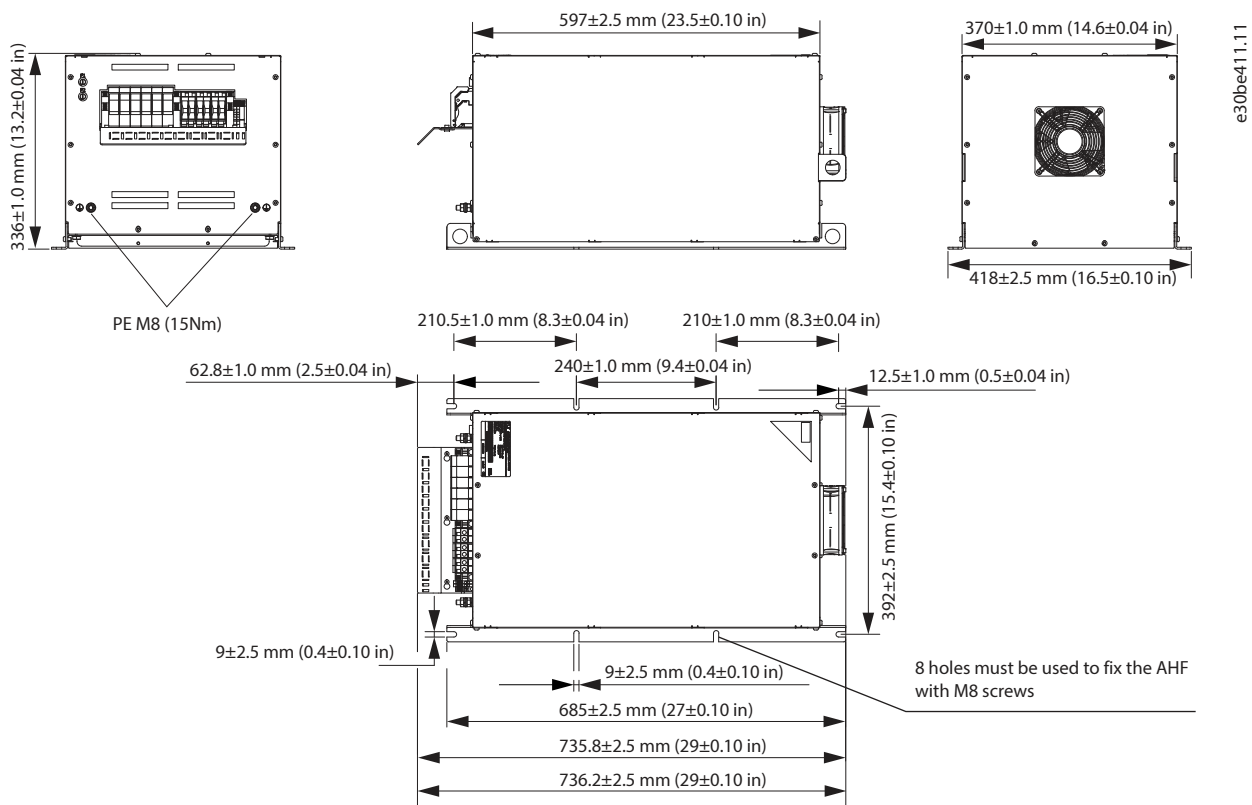

Figure 49: IP20 X5-V3 External Fan

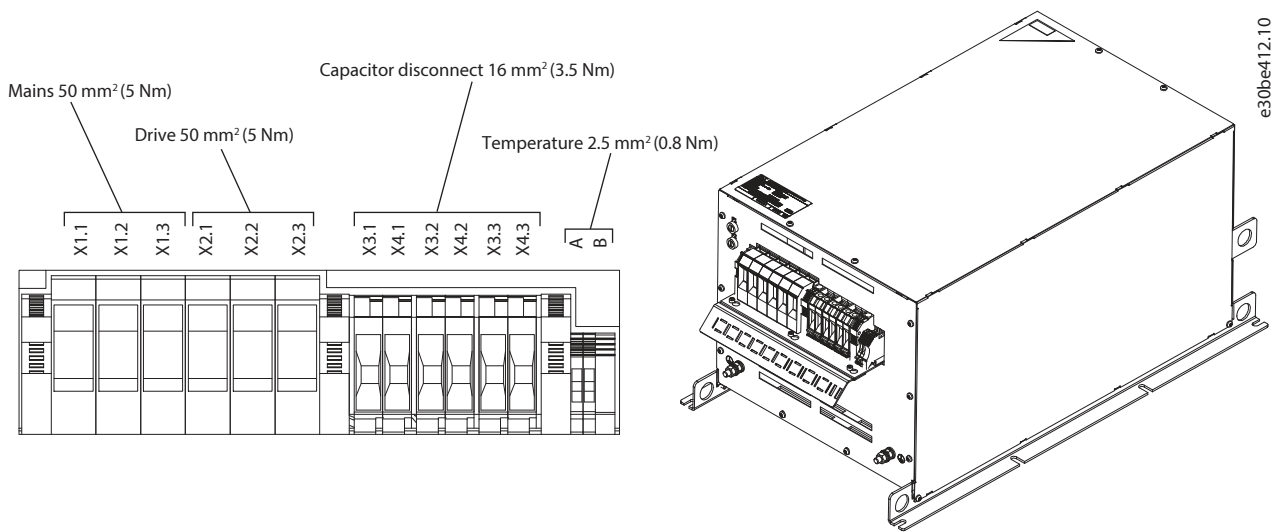

Figure 50: IP20 X5-V3 External Fan, Terminal Designation and 3D View

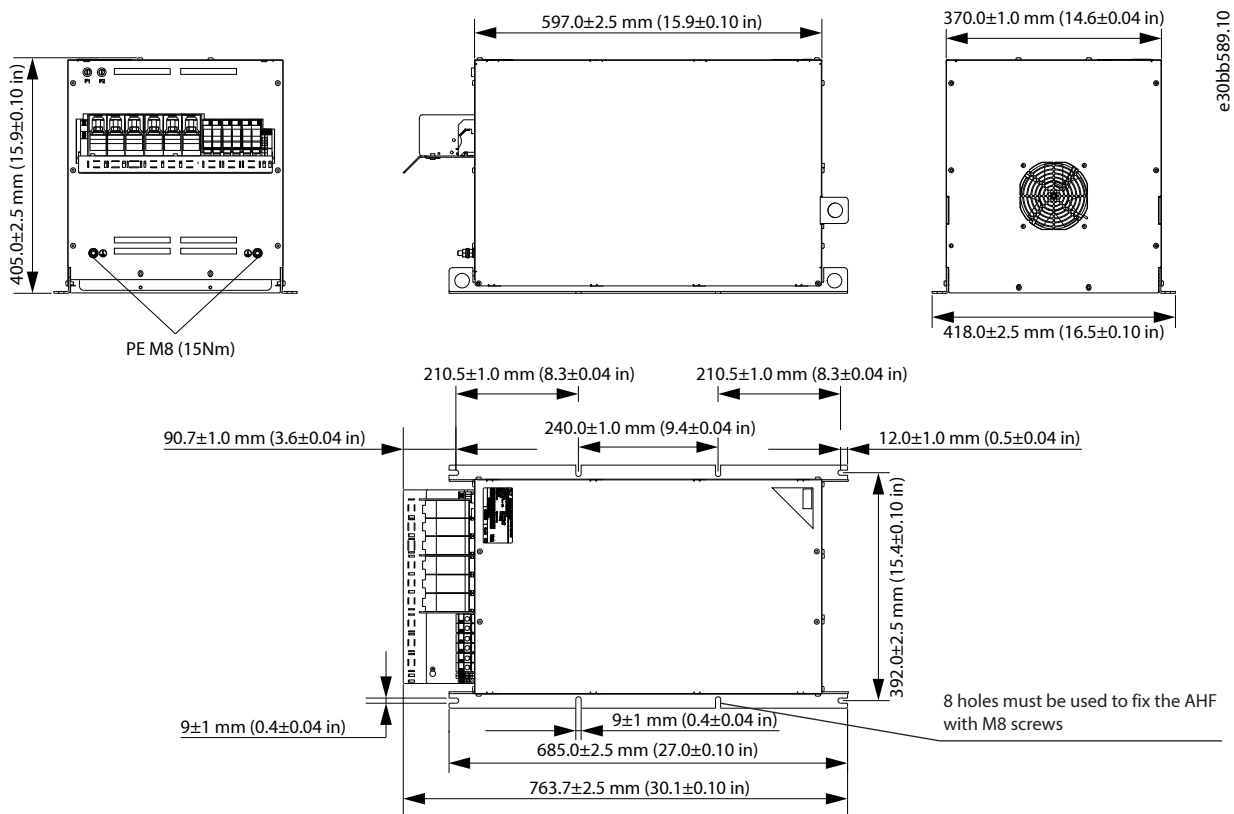

Figure 51: IP20 X6-V3 Internal Fan

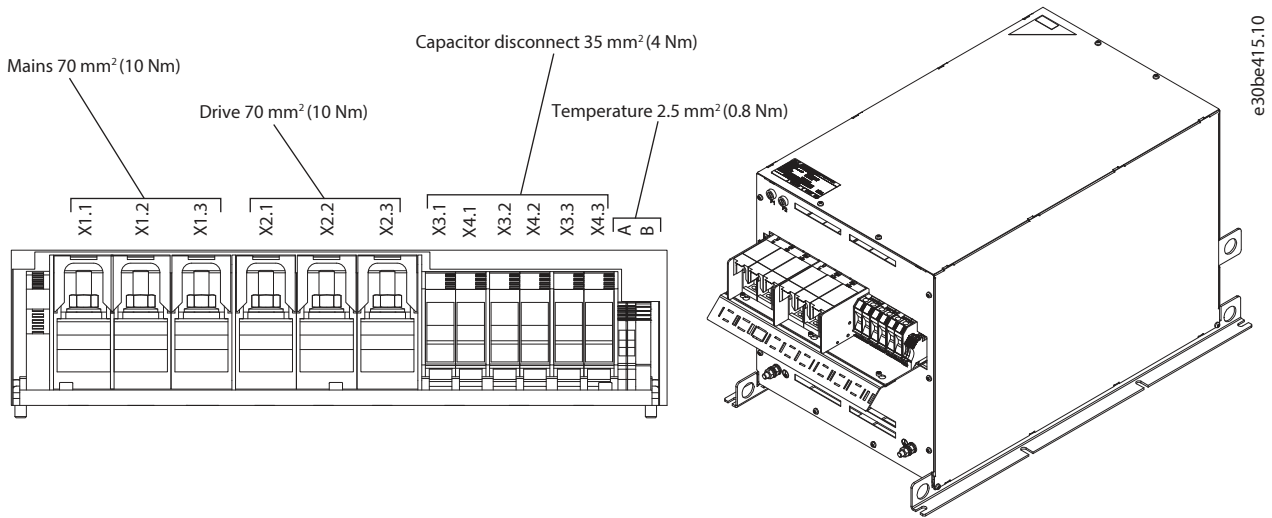

Figure 52: IP20 X6-V3 Internal Fan, Terminal Designation and 3D View

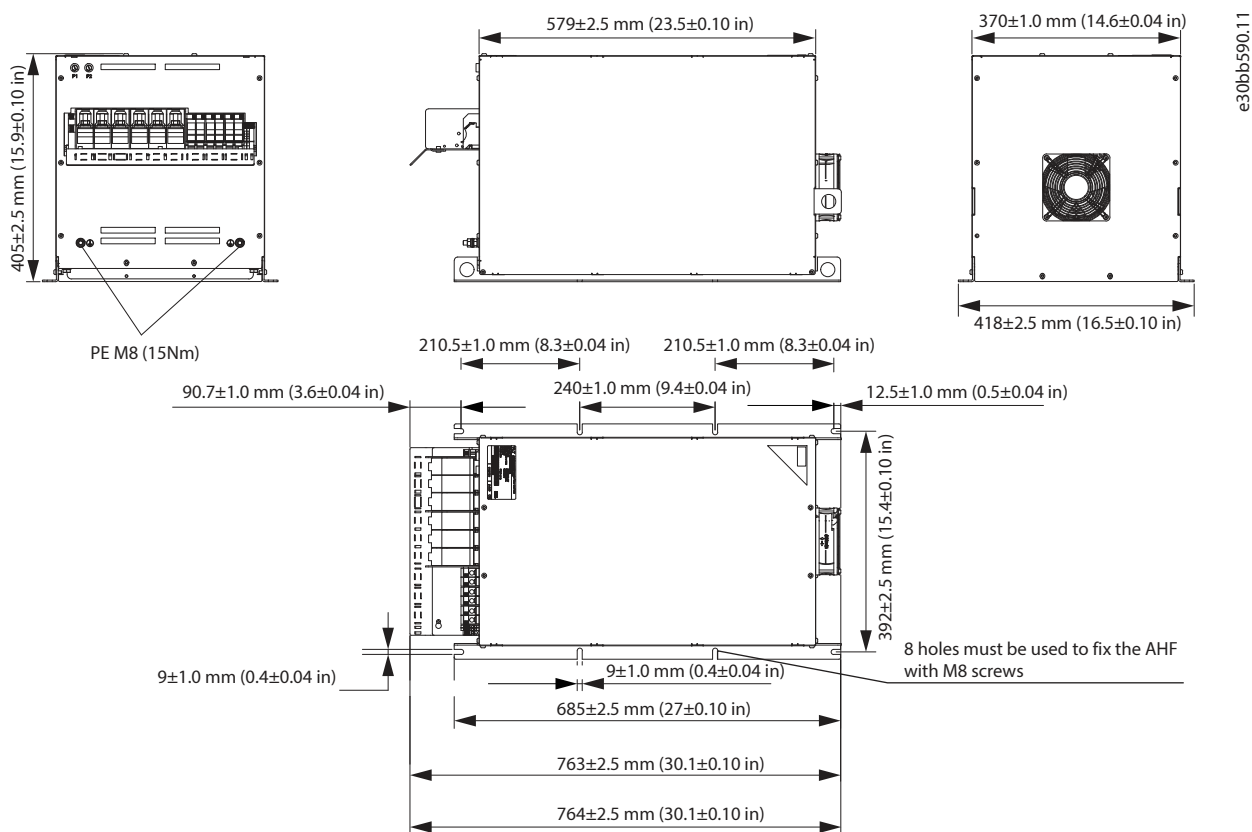

Figure 53: IP20 X6-V3 External Fan

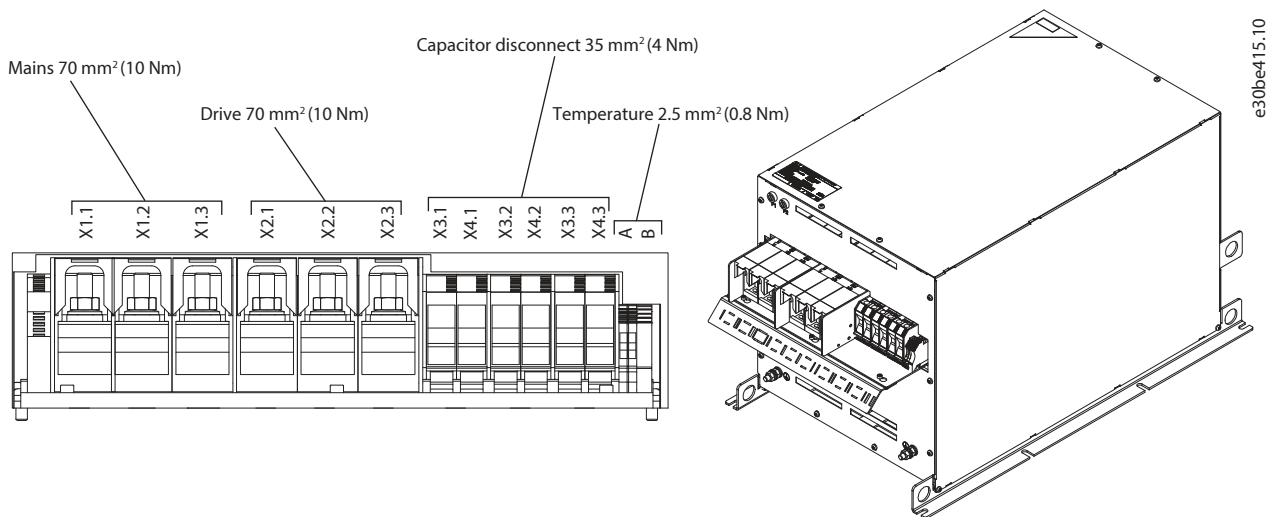

Figure 54: IP20 X6-V3 External Fan, Terminal Designation and 3D View

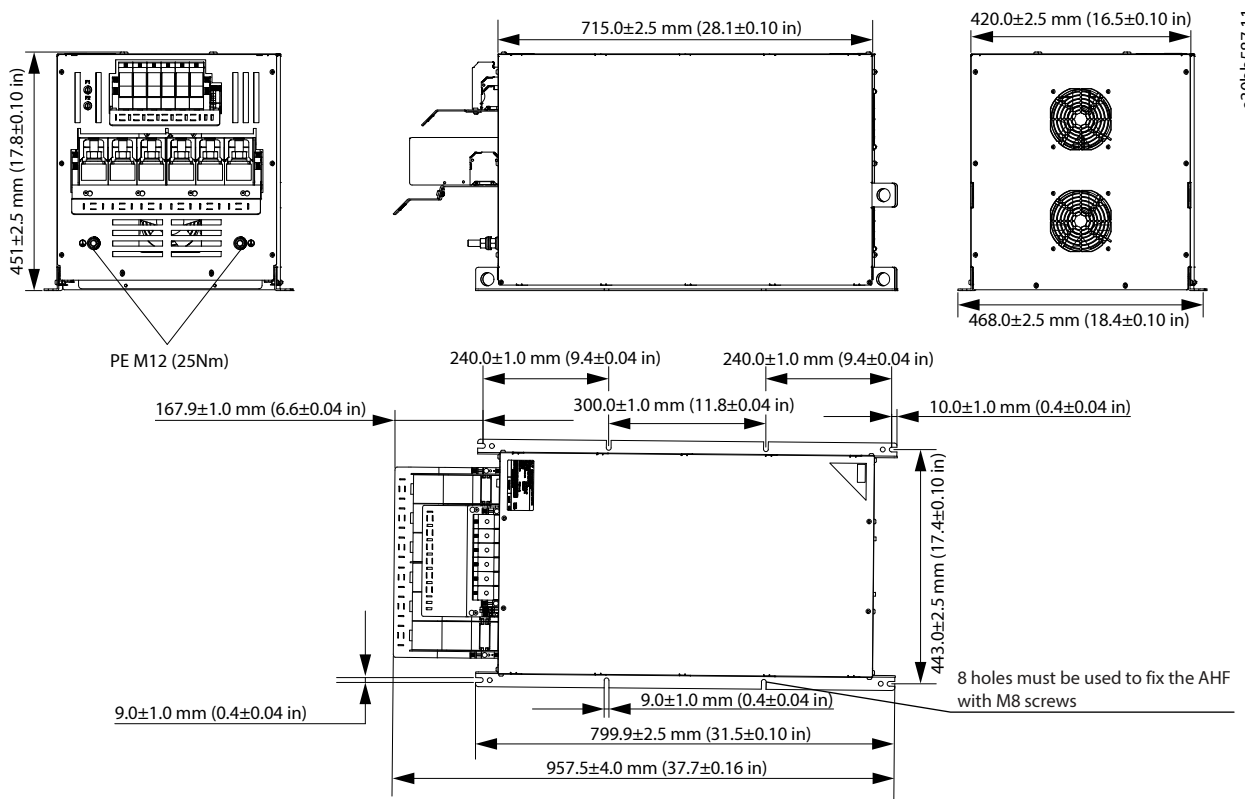

Figure 55: IP20 X7-V3 Internal Fan

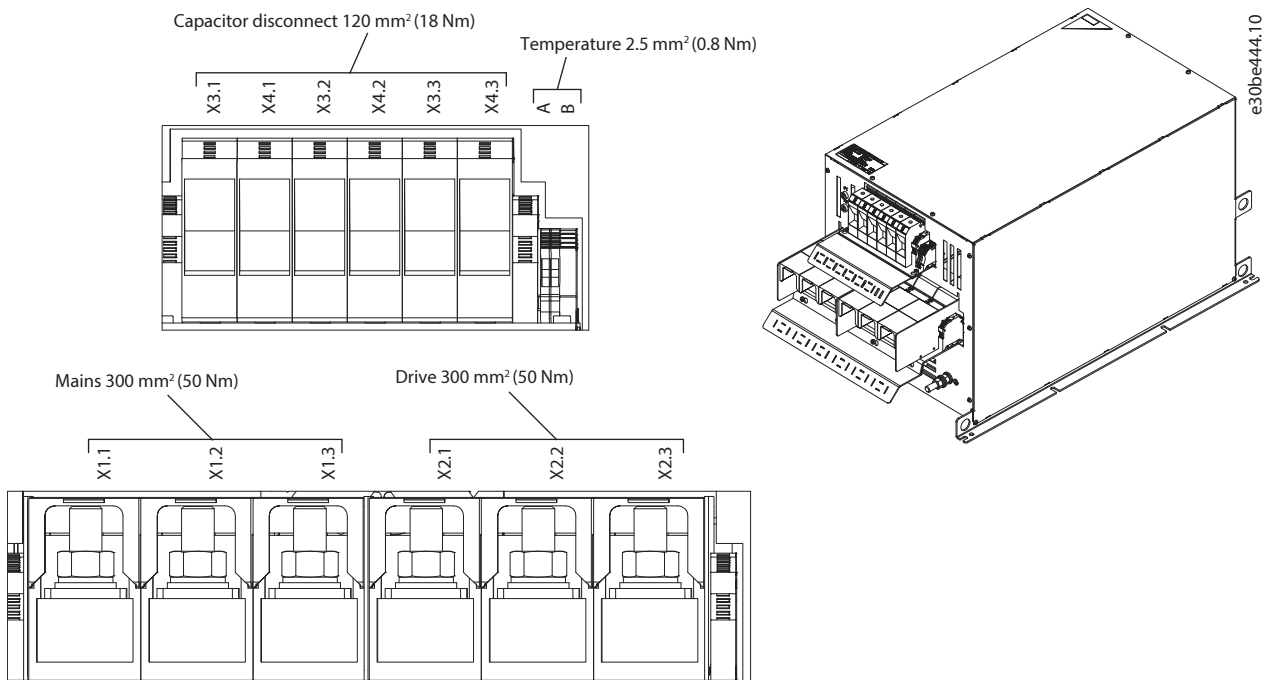

Figure 56: IP20 X7-V3 Internal Fan, Terminal Designation and 3D View

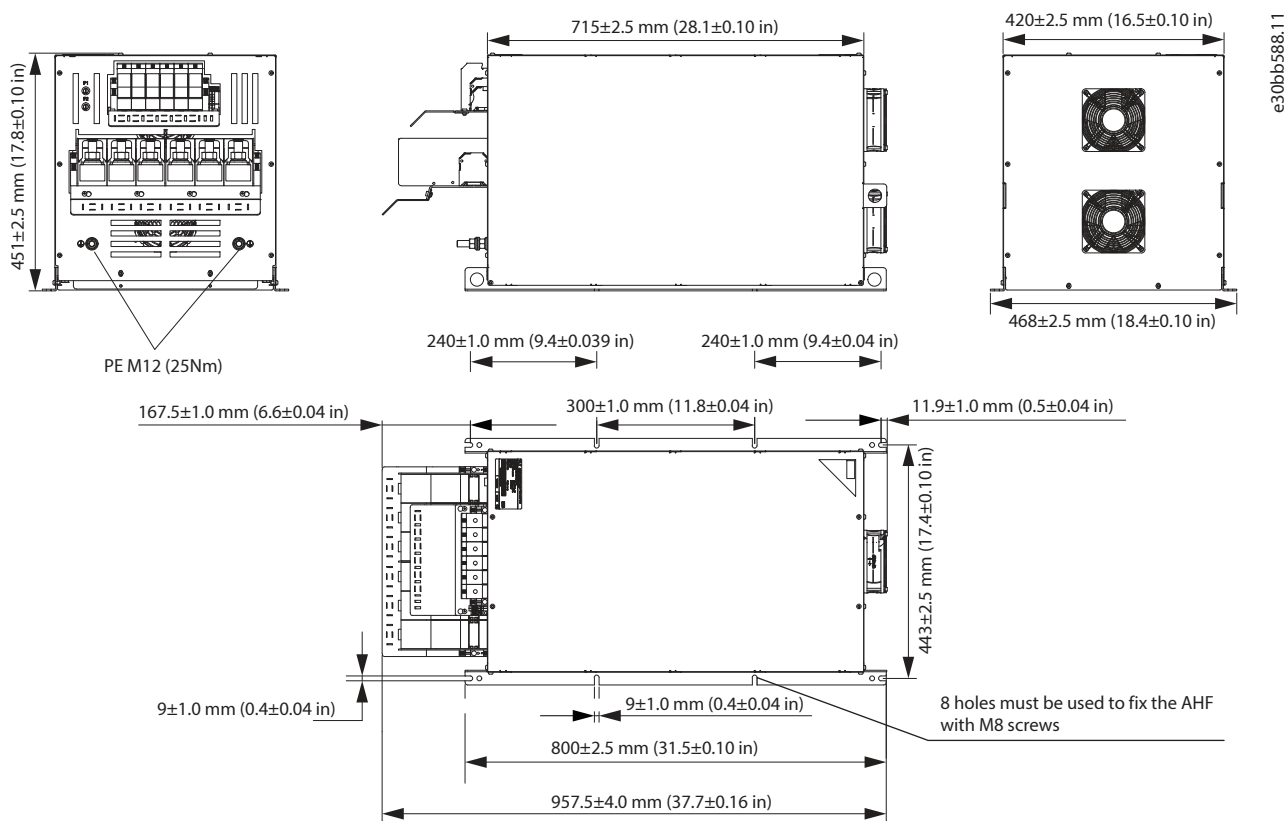

Figure 57: IP20 X7-V3 External Fan

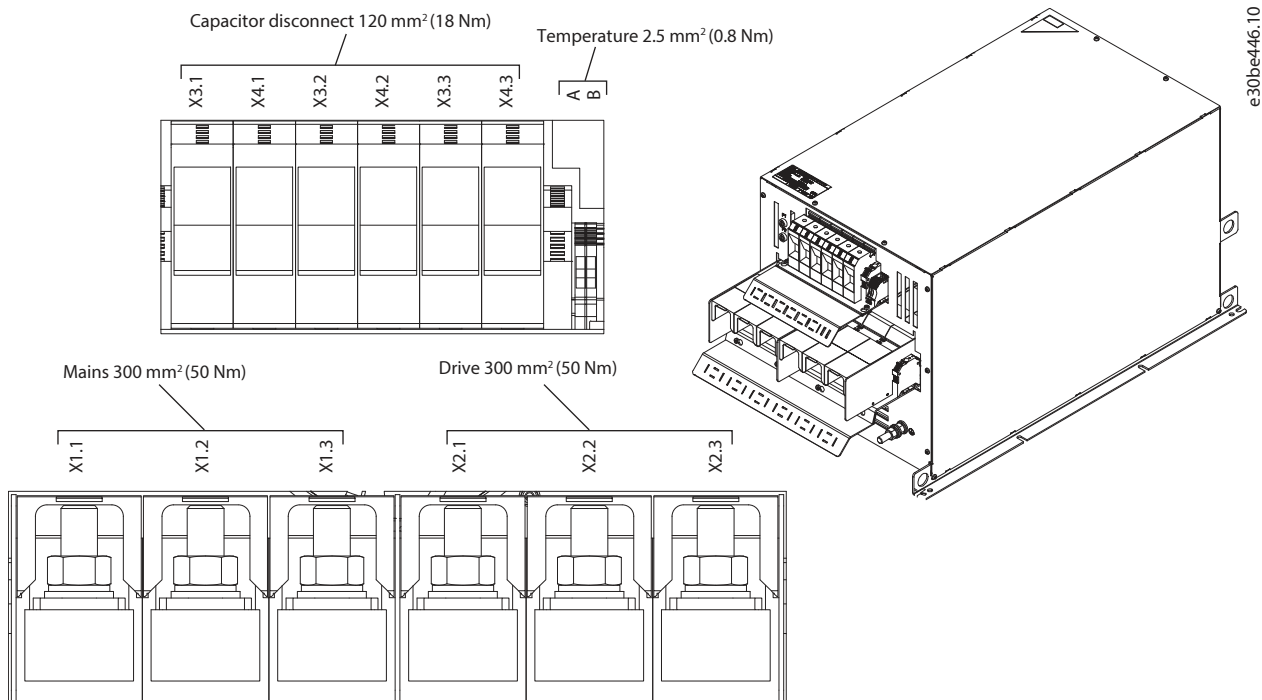

Figure 58: IP20 X7-V3 External Fan, Terminal Designation and 3D View

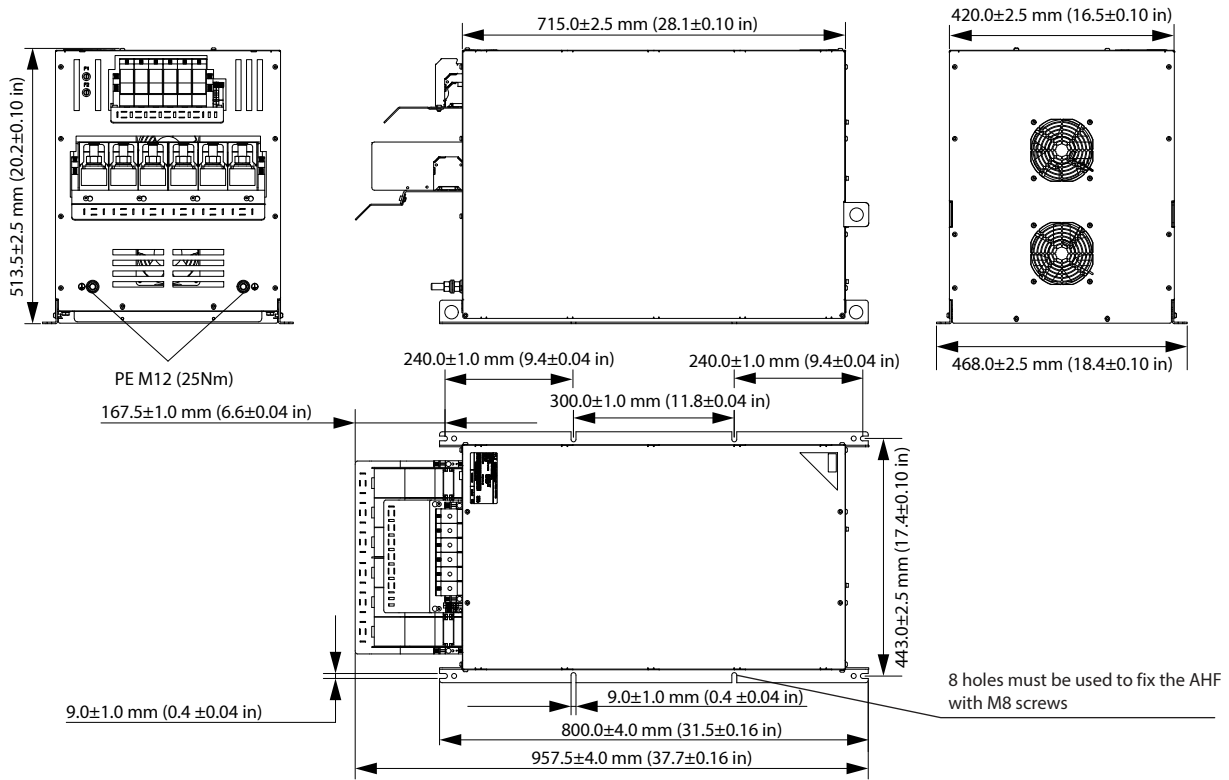

Figure 59: IP20 X8-V3 Internal Fan

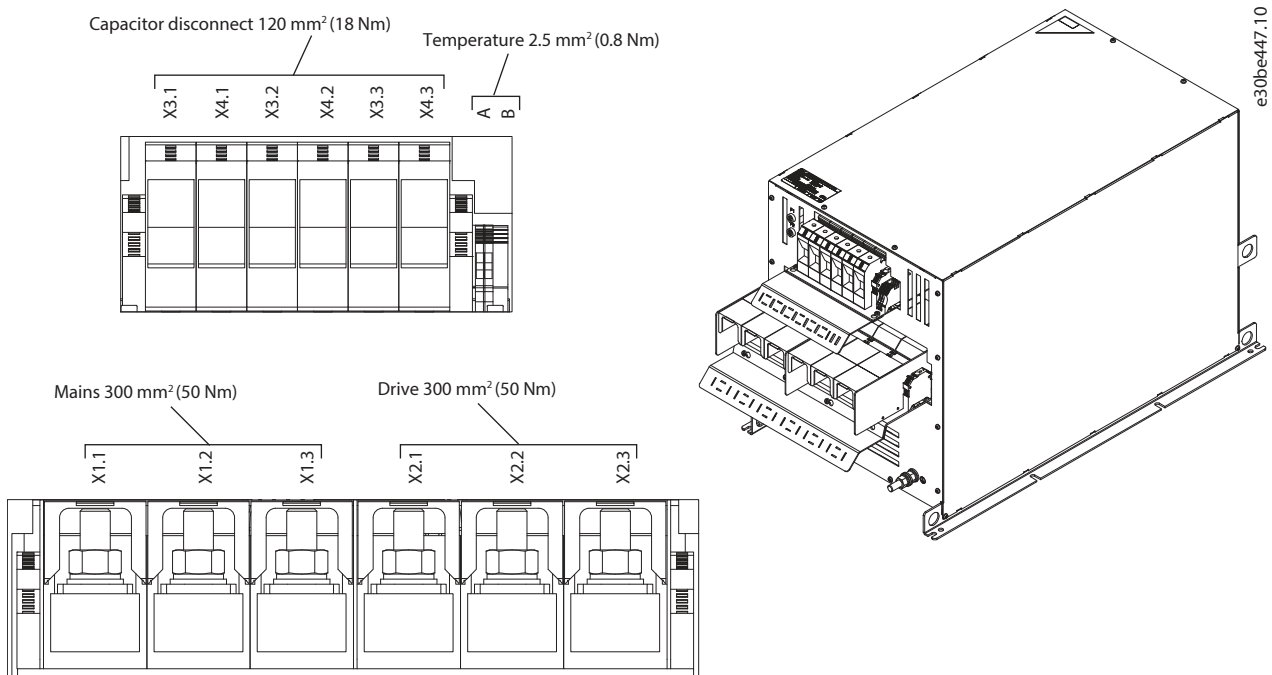

Figure 60: IP20 X8-V3 Internal Fan, Terminal Designation and 3D View

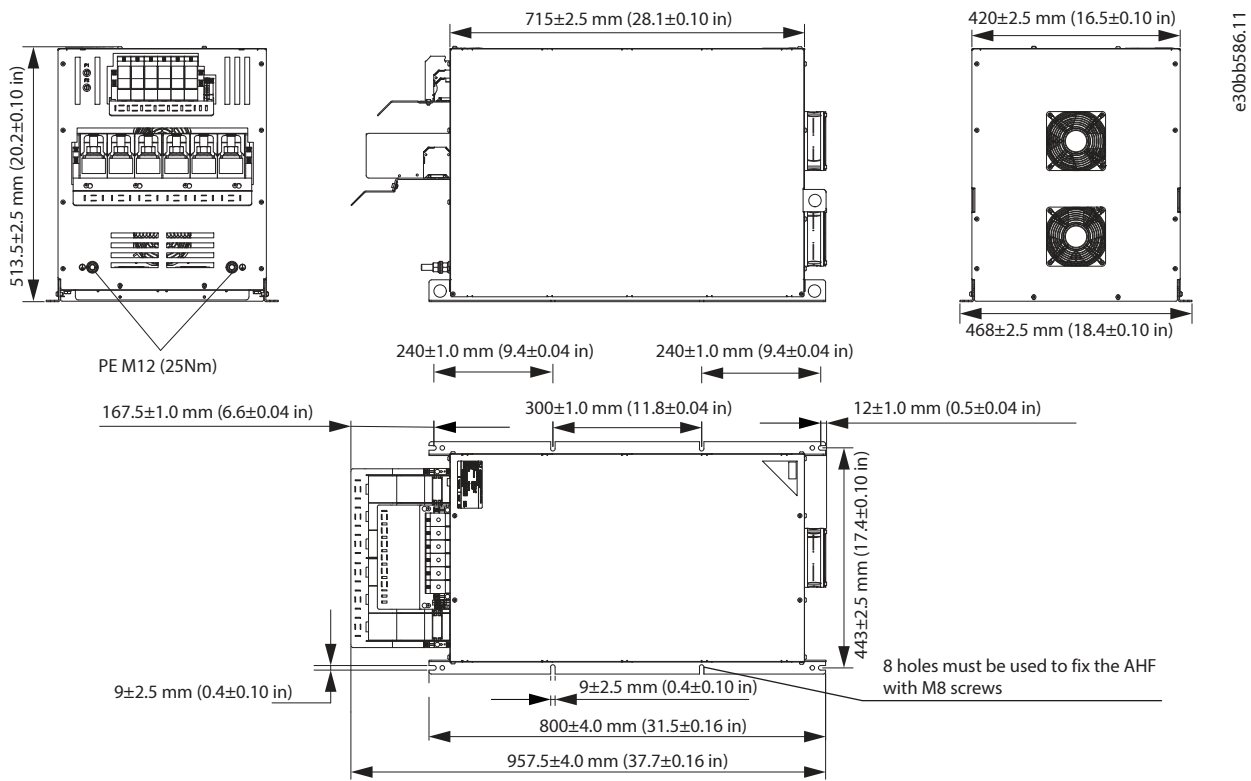

Figure 61: IP20 X8-V3 External Fan

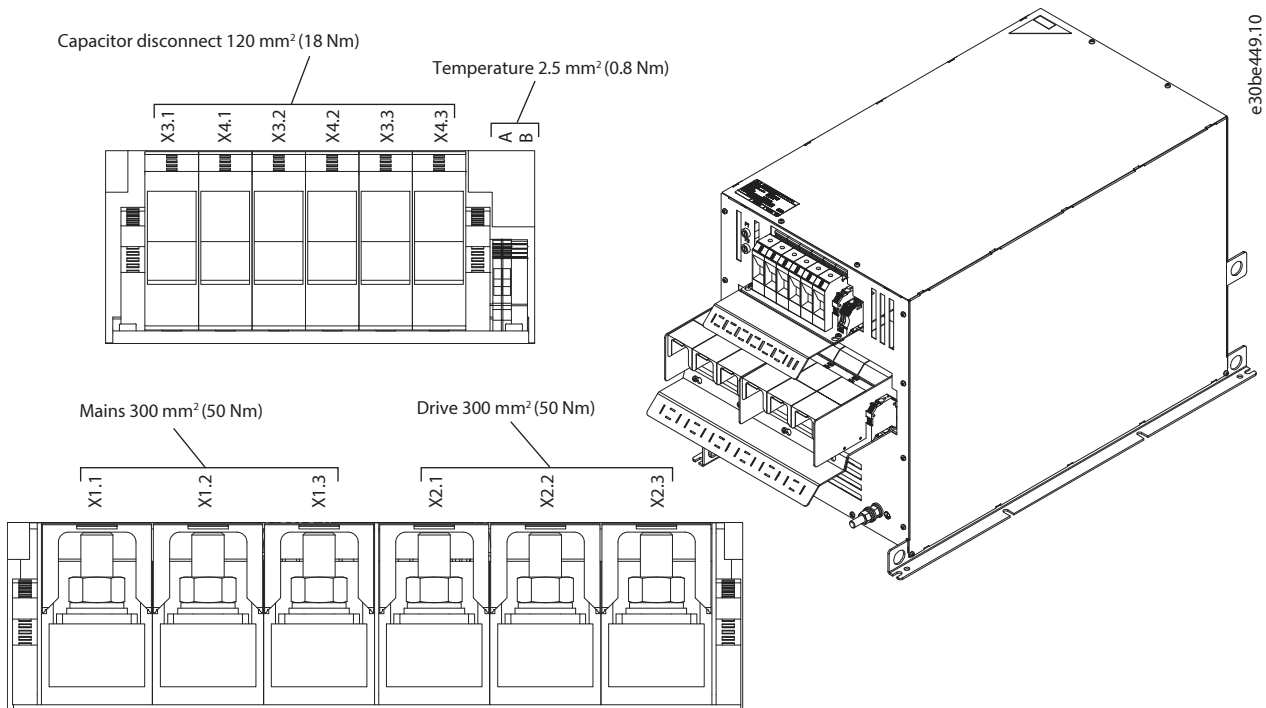

Figure 62: IP20 X8-V3 External Fan, Terminal Designation and 3D View

7.4.4 IP21 Enclosures

Mechanical drawings in 2D PDF, 2D DWG, and 3D STEP can be downloaded from danfoss.com.

NOTICE

The illustrations in this chapter are showing the entire unit: The AHF IP20 filter with the matching optional IP21/NEMA 1 upgrade kit mounted. The illustrations all show filters with external fan, but the dimensions are valid for filters with both internal and external fan. Always mount the AHF according to the definitions valid for the basic AHF IP20 unit.

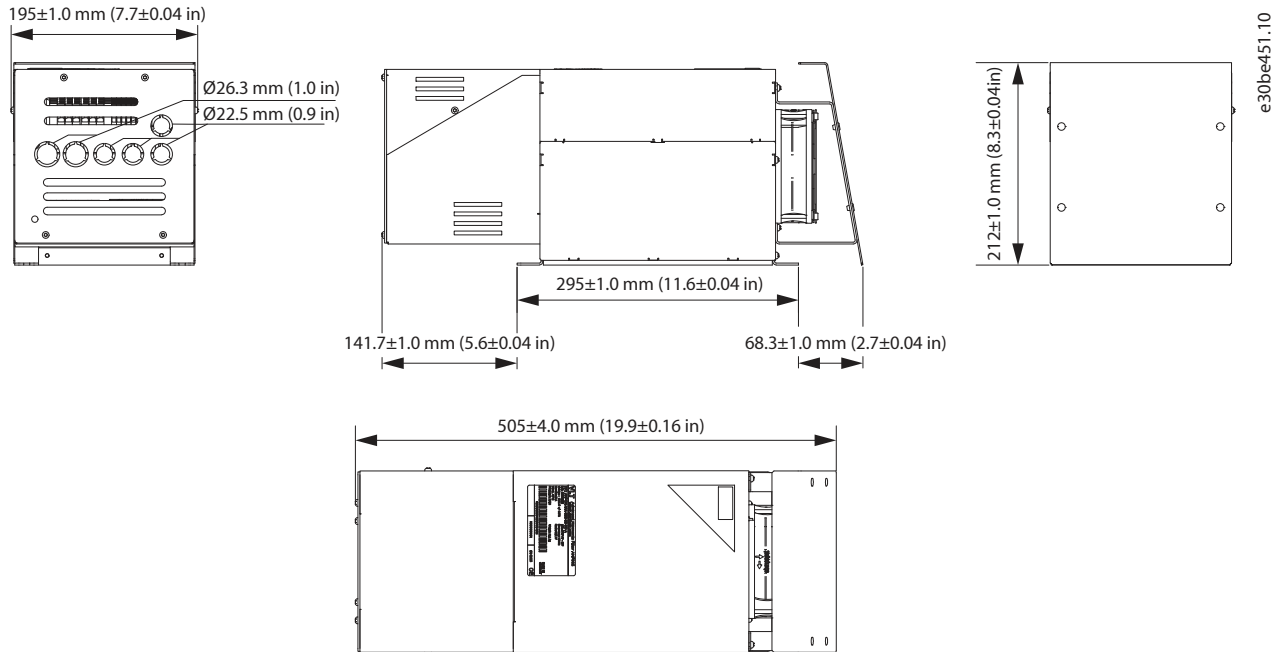

Figure 63: IP21 X1-V3 Internal and External Fan

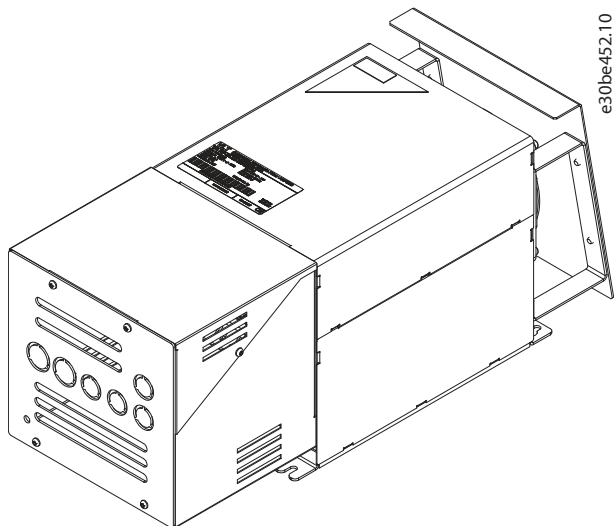

Figure 64: IP21 X1-V3 Internal and External Fan, 3D View

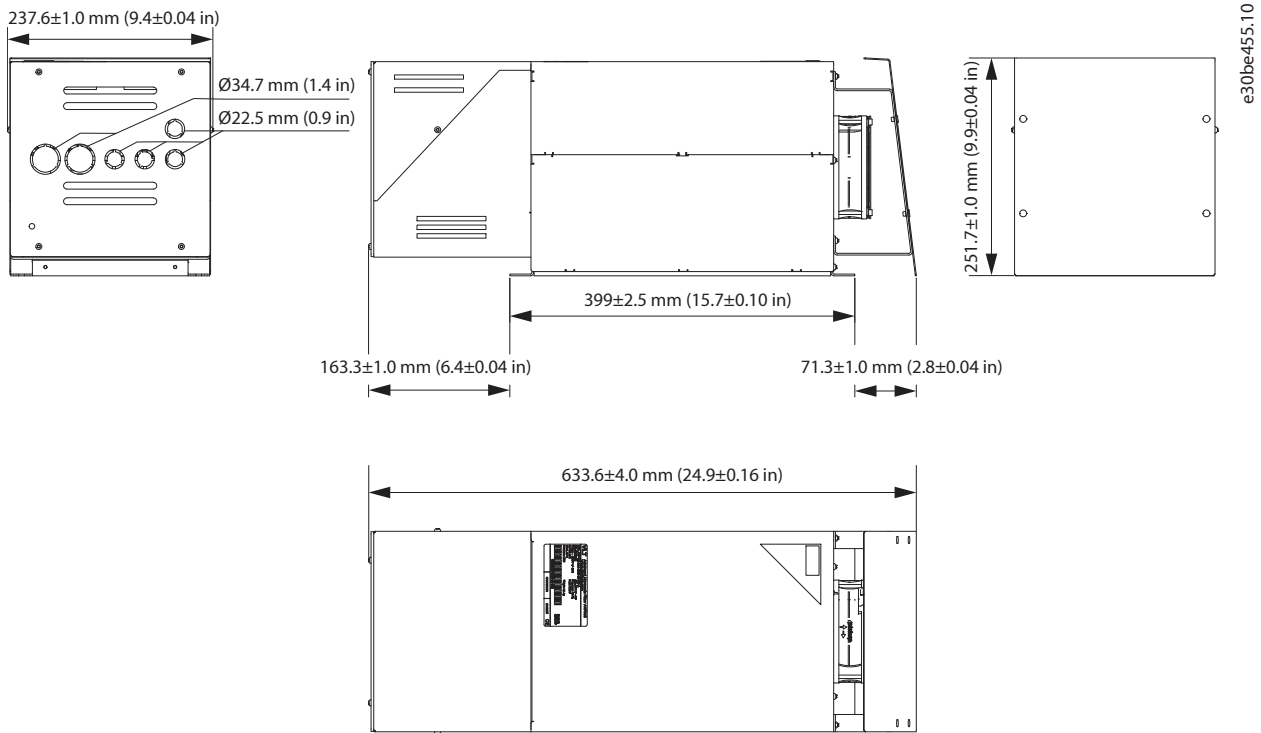

Figure 65: IP21 X2-V3 Internal and External Fan

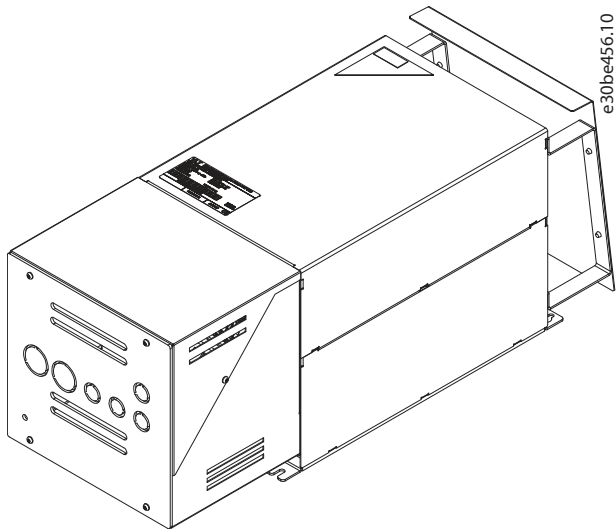

Figure 66: IP21 X2-V3 Internal and External Fan, 3D View

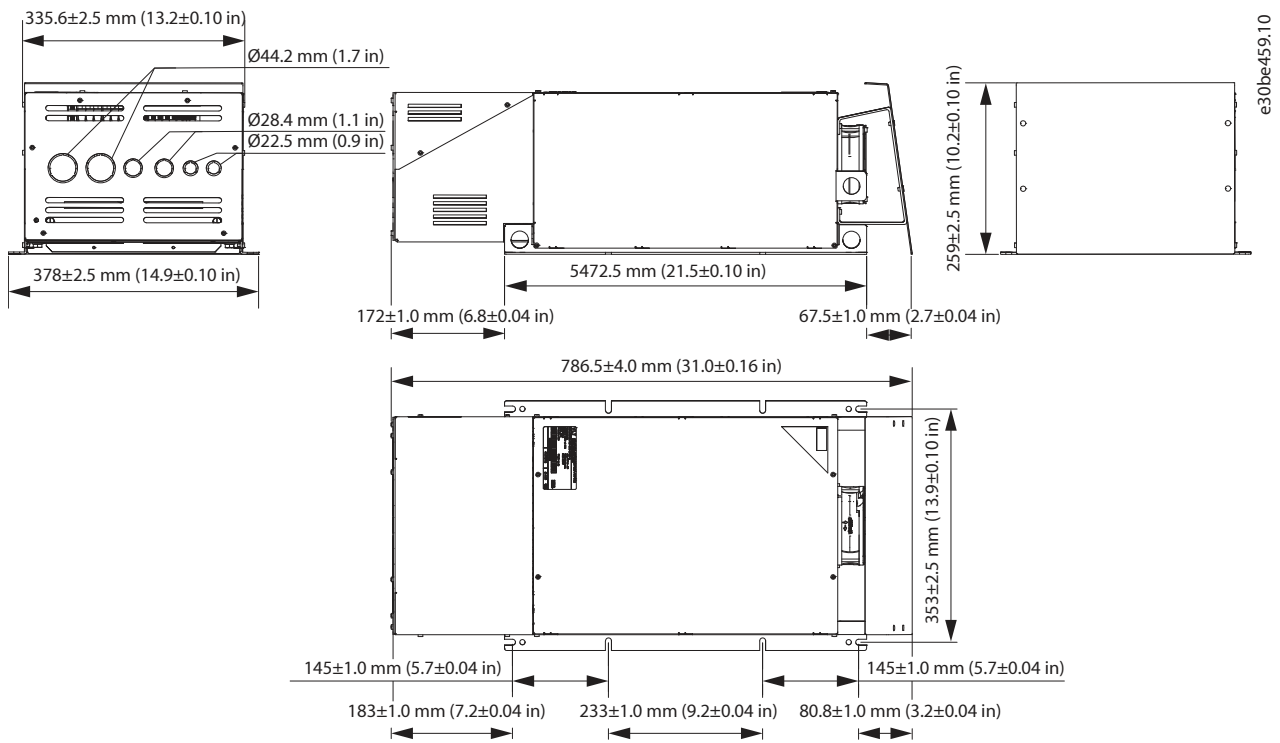

Figure 67: IP21 X3-V3 Internal and External Fan

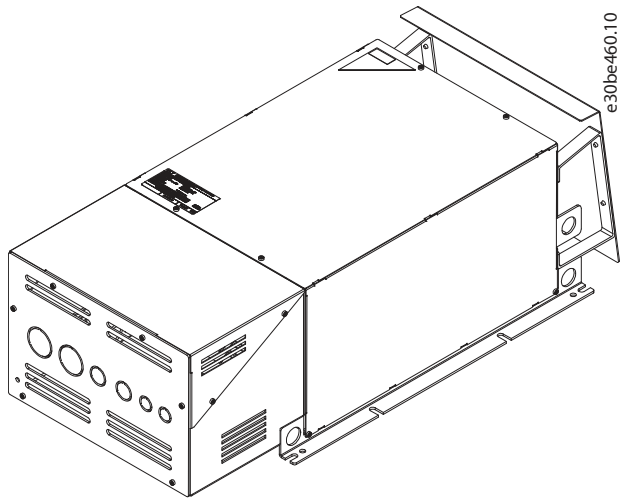

Figure 68: IP21 X3-V3 Internal and Internal Fan, 3D View

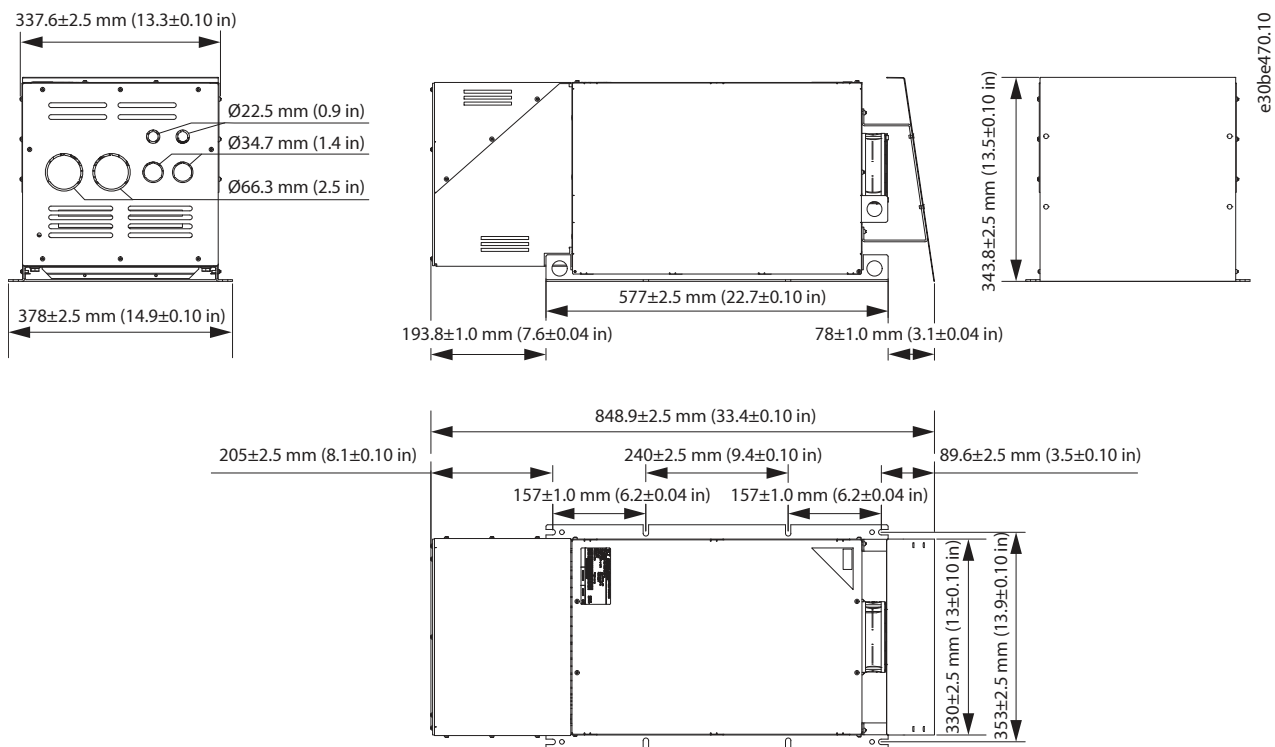

Figure 69: IP21 X4-V3 Internal and External Fan

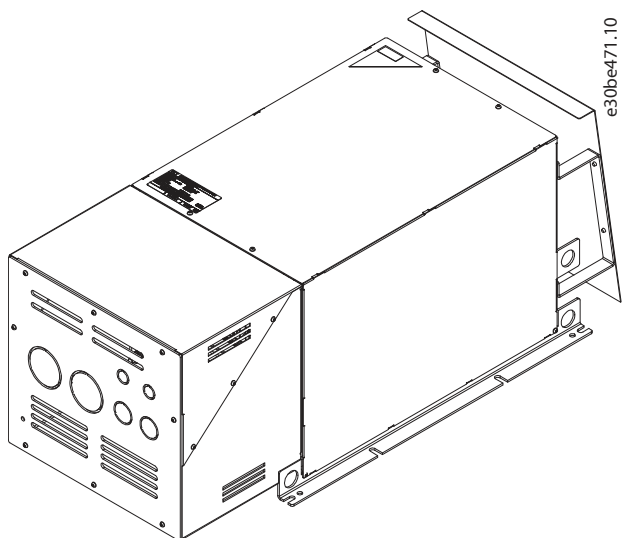

Figure 70: IP21 X4-V3 Internal and External Fan, 3D View

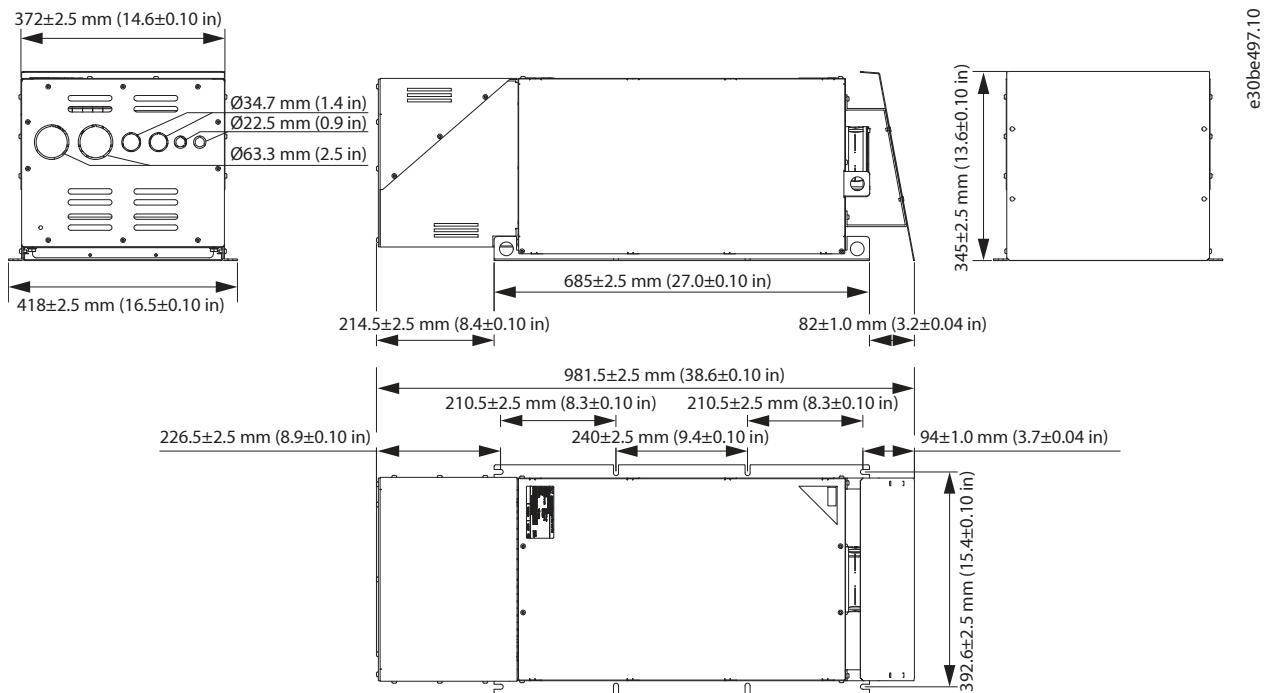

Figure 71: IP21 X5-V3 Internal and External Fan

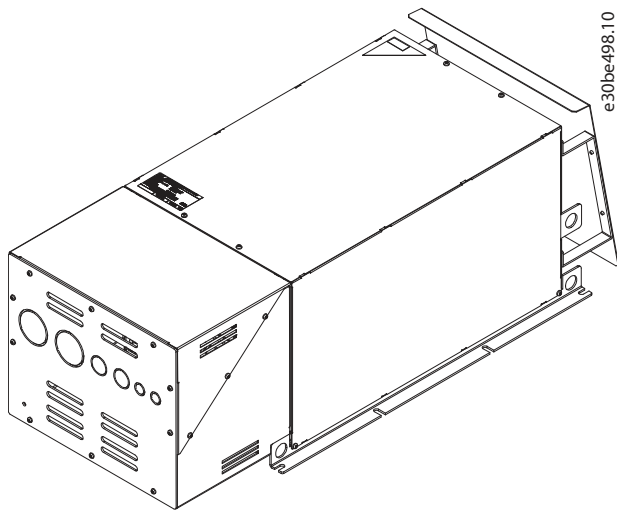

Figure 72: IP21 X5-V3 Internal and External Fan, 3D View

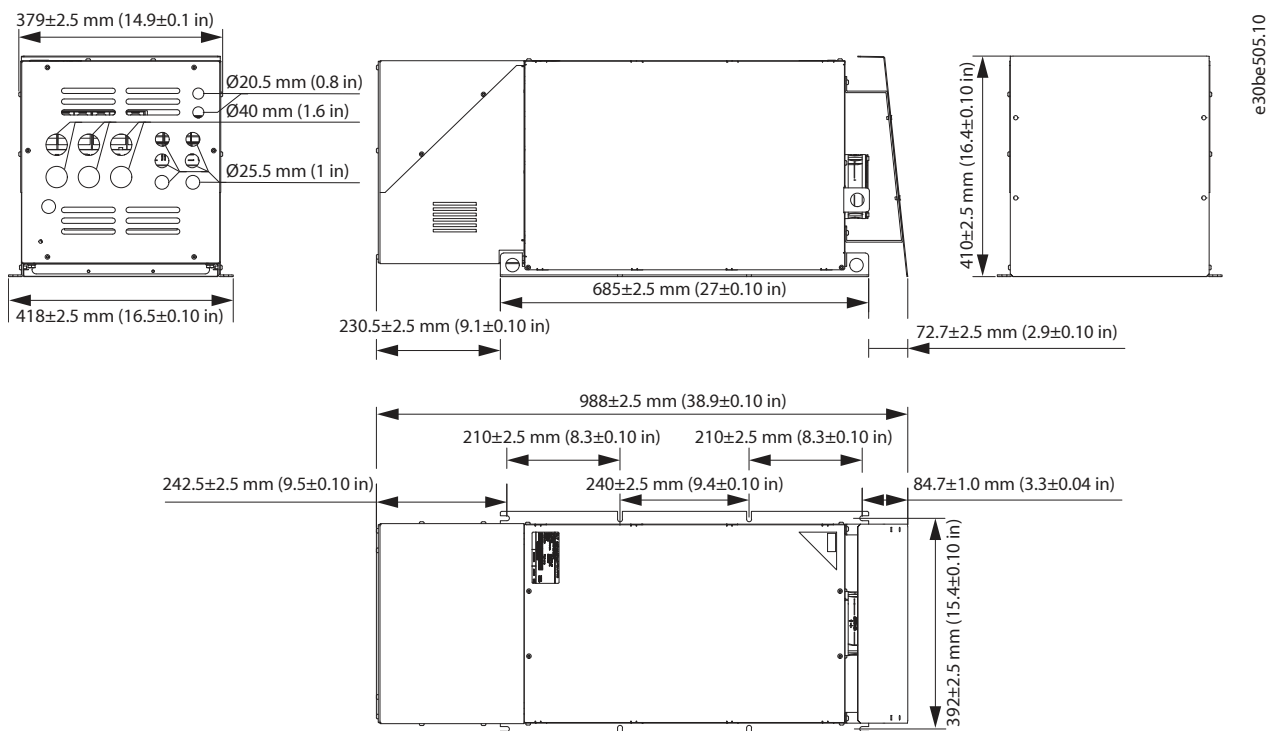

Figure 73: IP21 X6-V3 Internal and External Fan

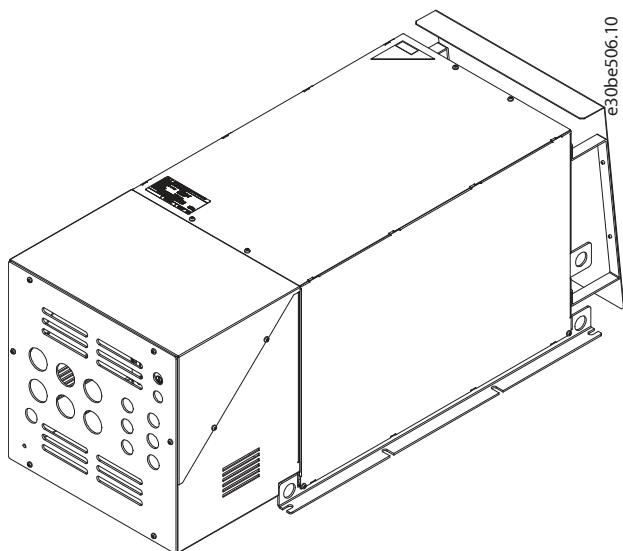

Figure 74: IP21 X6-V3 Internal and External Fan, 3D View

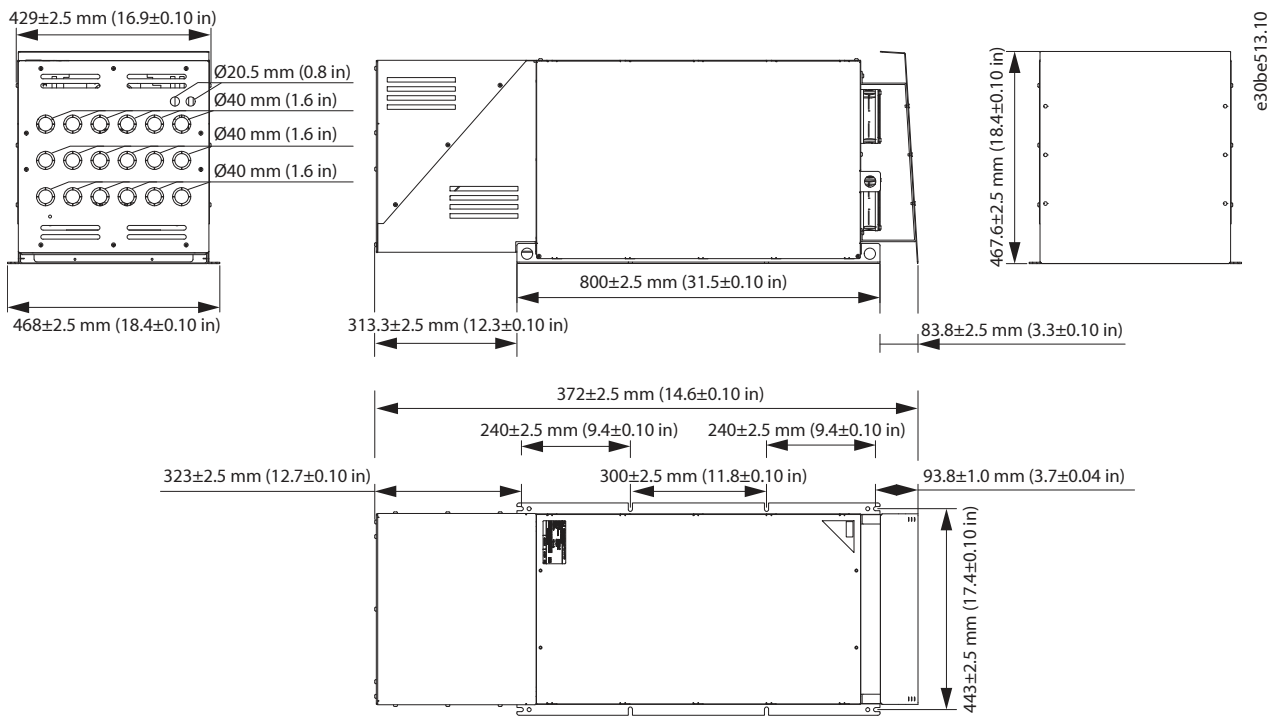

Figure 75: IP21 X7-V3 Internal and External Fan

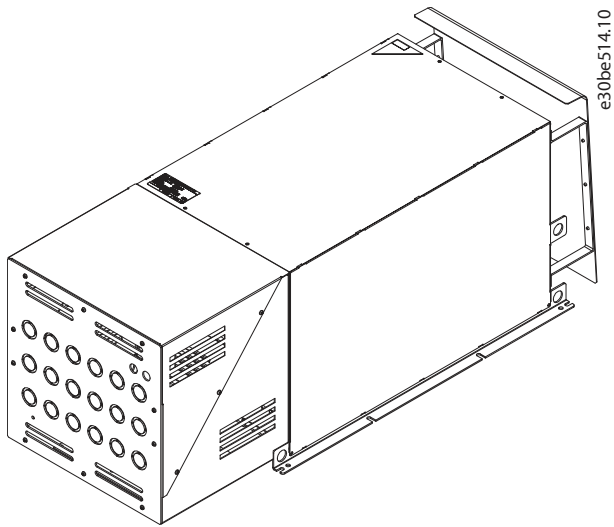

Figure 76: IP21 X7-V3 Internal and External Fan, 3D View

7.4.5 Backplate Dimensions

The backplate dimensions for VLT® Advanced Harmonic Filter AHF 005/AHF 010 enclosure X1 and X2 are shown in [Figure 79](#).

The dimensions for enclosures X3, X4, X5, X6, X7, and X8 are shown in [Figure 80](#).

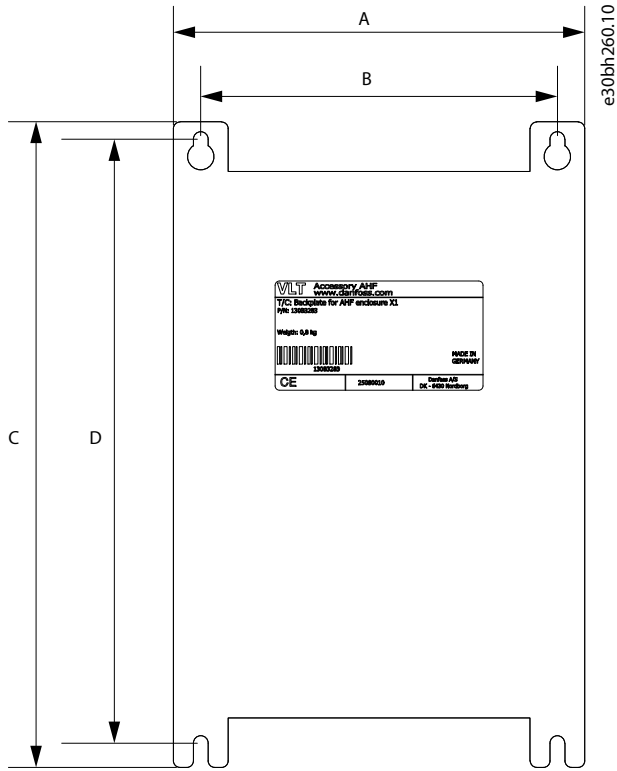

Figure 79: Backplate Dimensions for X1 and X2 Enclosures

Table 57: Backplate Dimensions for X1 and X2 Enclosures

	Enclosure X1 130B3283 [mm (in)] ⁽¹⁾	Enclosure X2 130B3284 [mm (in)] ⁽¹⁾
A	188 (7.4)	230 (9.1)
B	163 (6.4)	205 (8.1)
C	295 (11.6)	399 (15.7)
D	276 (10.9)	380 (15)

1) The thickness of the backplate is 2 mm (0.08 in)

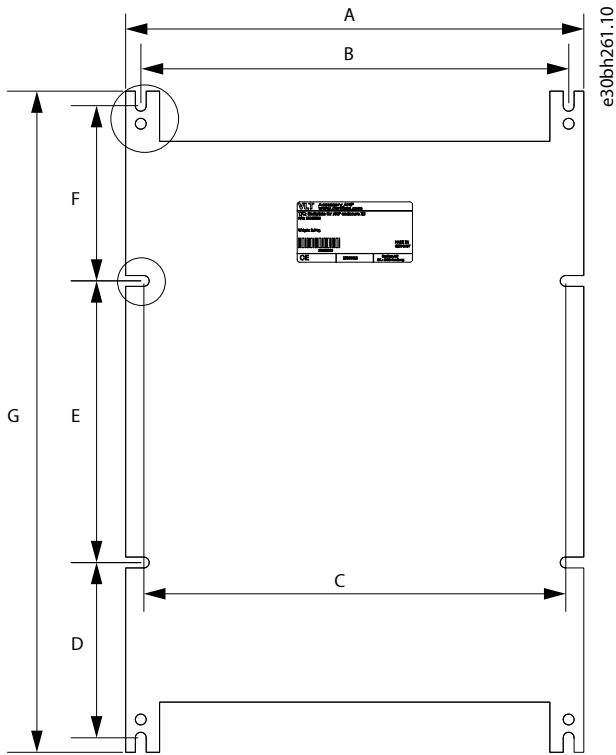

Figure 80: Backplate Dimensions for X3, X4, X5, X6, X7, and X8 Enclosures

Table 58: Backplate Dimensions for X3, X4, X5, X6, X7, and X8 Enclosures

	Enclosure X3 130B3285 [mm (in)] ⁽¹⁾	Enclosure X4 130B3286 [mm (in)] ⁽¹⁾	Enclosures X5 and X6 130B3287 [mm (in)] ⁽¹⁾	Enclosures X7 and X8 130B3288 [mm (in)] ⁽¹⁾
A	378 (14.9)	378 (14.9)	418 (16.5)	468 (18.4)
B	353 (13.9)	353 (13.9)	393 (15.5)	443 (17.4)
C	348 (13.7)	348 (13.7)	388 (15.3)	438 (17.2)
D	145 (5.7)	156.5 (6.2)	210.5 (8.3)	238 (9.4)
E	233 (9.2)	240 (6.2)	240 (9.4)	300 (11.8)
F	145 (5.7)	156.5 (6.2)	210.5 (8.3)	238 (9.4)
G	547 (21.5)	577 (22.7)	685 (27)	800 (31.5)

1) The thickness of the backplate is 2 mm (0.08 in)

7.5 Fuses

To protect the installation against electrical and fire hazards, all filters in an installation must be protected against short-circuiting and overcurrent according to national and international regulations.

To protect both frequency converter and filter, select the type of fuses recommended in the product-related frequency converter design guide. The maximum fuse rating per filter size is listed below.

NOTICE

In applications where filters are paralleled, it is sometimes necessary to install fuses in front of each filter and in front of the drive.

Table 59: Maximum Fuse Rating, 380–415 V, 50 Hz and 60 Hz

Filter current rating [A]	Maximum fuse size [A]	Fuses (type)
10	16	gRL 690 V AC
14	35	gRL 690 V AC
22	35	gRL 690 V AC
29	50	gRL 690 V AC
34	50	gRL 690 V AC
40	63	gRL 690 V AC
55	80	gRL 690 V AC
66	125	gRL 690 V AC
82	160	gRL 690 V AC
96	250	gRL 690 V AC
133	250	gRL 690 V AC
171	315	gRL 690 V AC
204	350	gRL 690 V AC
251	400	gRL 690 V AC
304	500	gRL 690 V AC
325	630	gRL 690 V AC
381	630	gRL 690 V AC
480	800	gRL 690 V AC

Table 60: Maximum Fuse Rating, 440–480 V, 60 Hz

Filter rating [A]	Maximum fuse size	Fuses (type) ⁽¹⁾
10	20	Class J, 600 V AC, rated circuit breaker capacity 100 kA
14	35	Class J, 600 V AC, rated circuit breaker capacity 100 kA
19	35	Class J, 600 V AC, rated circuit breaker capacity 100 kA
25	50	Class J, 600 V AC, rated circuit breaker capacity 100 kA
31	50	Class J, 600 V AC, rated circuit breaker capacity 100 kA
36	60	Class J, 600 V AC, rated circuit breaker capacity 100 kA
48	80	Class J, 600 V AC, rated circuit breaker capacity 100 kA
60	125	Class J, 600 V AC, rated circuit breaker capacity 100 kA

Table 60: Maximum Fuse Rating, 440–480 V, 60 Hz - (continued)

Filter rating [A]	Maximum fuse size	Fuses (type) ⁽¹⁾
73	150	Class J, 600 V AC, rated circuit breaker capacity 100 kA
95	250	Class J, 600 V AC, rated circuit breaker capacity 100 kA
118	250	Class J, 600 V AC, rated circuit breaker capacity 100 kA
154	300	Class J, 600 V AC, rated circuit breaker capacity 100 kA
183	350	Class J, 600 V AC, rated circuit breaker capacity 100 kA
231	400	Class J, 600 V AC, rated circuit breaker capacity 100 kA
291	600	Class J, 600 V AC, rated circuit breaker capacity 100 kA
355	600	Class J, 600 V AC, rated circuit breaker capacity 100 kA
380	600	Class J, 600 V AC, rated circuit breaker capacity 100 kA
436	600	Class J, 600 V AC, rated circuit breaker capacity 100 kA

1) Specified type is a UL requirement

Table 61: Maximum Fuse Rating, 600 V, 60 Hz

Filter rating [A]	Maximum fuse size	Fuses (type) ⁽¹⁾
15	35	Class J, 600 V AC, rated circuit breaker capacity 100 kA
20	35	Class J, 600 V AC, rated circuit breaker capacity 100 kA
24	50	Class J, 600 V AC, rated circuit breaker capacity 100 kA
29	50	Class J, 600 V AC, rated circuit breaker capacity 100 kA
36	60	Class J, 600 V AC, rated circuit breaker capacity 100 kA
50	80	Class J, 600 V AC, rated circuit breaker capacity 100 kA
58	100	Class J, 600 V AC, rated circuit breaker capacity 100 kA
77	125	Class J, 600 V AC, rated circuit breaker capacity 100 kA
87	150	Class J, 600 V AC, rated circuit breaker capacity 100 kA
109	200	Class J, 600 V AC, rated circuit breaker capacity 100 kA
128	250	Class J, 600 V AC, rated circuit breaker capacity 100 kA
155	300	Class J, 600 V AC, rated circuit breaker capacity 100 kA
197	350	Class J, 600 V AC, rated circuit breaker capacity 100 kA
240	400	Class J, 600 V AC, rated circuit breaker capacity 100 kA
296	500	Class J, 600 V AC, rated circuit breaker capacity 100 kA
366	600	Class J, 600 V AC, rated circuit breaker capacity 100 kA
395	600	Class J, 600 V AC, rated circuit breaker capacity 100 kA

1) Specified type is a UL requirement

Table 62: Maximum Fuse Rating, 500–690 V, 50 Hz

Filter rating [A]	Maximum fuse size	Fuses (type)
15	35	gRL 690 V AC
20	35	gRL 690 V AC

Table 62: Maximum Fuse Rating, 500–690 V, 50 Hz - (continued)

Filter rating [A]	Maximum fuse size	Fuses (type)
24	50	gRL 690 V AC
29	50	gRL 690 V AC
36	63	gRL 690 V AC
50	80	gRL 690 V AC
58	125	gRL 690 V AC
77	160	gRL 690 V AC
87	250	gRL 690 V AC
109	250	gRL 690 V AC
128	250	gRL 690 V AC
155	315	gRL 690 V AC
197	350	gRL 690 V AC
240	400	gRL 690 V AC
296	500	gRL 690 V AC
366	630	gRL 690 V AC
395	630	gRL 690 V AC

8 Spare Parts

8.1 Introduction to Spare Parts

NOTICE

ATTENTION TO REVISION NUMBER DURING SERVICING

The VLT® Advanced Harmonic Filter AHF001/AHF 010 program is constantly optimized, introducing differences between the individual designs. Vital differences are managed through revision control of the individual designs.

Differences between the individual revisions can lead to different spare parts. It is important to select matching spare parts according to the revision number of the actual filter. The spare part selection tables include a reference to the matching revision number in the AHF serial number string. The specific revision number is identified in the serial number string of the AHF listed on the nameplate of the actual filter. Characters 5 and 6 in the serial number string are the identifiers of the revision number.

Since the introduction of the AHF program, the following revisions have been introduced:

- 01
- 02
- 03

The current version featuring variable-speed fan is identified by revision number 03.

SN: 0100 03 - 378

Characters 5 and 6 are 03, confirming that this is revision number 03.



Figure 81: Product Label

A Identification of revision number

NOTICE

DISCHARGE TIME

The VLT® Advanced Harmonic Filter AHF 005/AHF 010 contain capacitors, which can remain charged even when the drive is not powered.

Failure to wait the specified time after power has been removed before performing service or repair work could result in death or serious injury.

- Stop the motor.
- Disconnect AC mains, permanent magnet type motors, and remote DC-link supplies, including battery back-ups, UPS, and DC-link connections to other drives.
- Wait for the capacitors to discharge fully. The minimum waiting time is specified in the table *Discharge time* and is also visible on the nameplate on top of the drive.
- Before performing any service or repair work, ensure that the voltage is 0 between the filter terminals X3.1, X3.2, and X3.3, and between the filter terminals X4.1, X4.2, and X4.3.

8.2 Selection Tables

8.2.1 Capacitor Kits

The spare part capacitor kits are complete kits including cabling and accessories for replacement.

The spare part capacitor kits are supporting the following filter programs:

- VLT® Advanced Harmonic Filter AHF 005, revision 01, 02 and 03.
- VLT® Advanced Harmonic Filter AHF 010, revision 01, 02 and 03.

Table 63: Capacitor Kits, 380–415 V, 50 Hz

380–415 V, 50 Hz	Capacitor kit	
Current rating [A]	Code number [P/N]	Description
10	175U1134	Capacitor Bank AHF3 DA/B 400V-50Hz-010A
14	175U1135	Capacitor Bank AHF3 DA/B 400V-50Hz-014A
22	175U1136	Capacitor Bank AHF3 DA/B 400V-50Hz-022A
29	175U1137	Capacitor Bank AHF3 DA/B 400V-50Hz-029A
34	175U1138	Capacitor Bank AHF3 DA/B 400V-50Hz-034A
40	175U1139	Capacitor Bank AHF3 DA/B 400V-50Hz-040A
55	175U1140	Capacitor Bank AHF3 DA/B 400V-50Hz-055A
66	175U1141	Capacitor Bank AHF3 DA/B 400V-50Hz-066A
82	175U1142	Capacitor Bank AHF3 DA/B 400V-50Hz-082A
96	175U1143	Capacitor Bank AHF3 DA/B 400V-50Hz-096A
133	175U1144	Capacitor Bank AHF3 DA/B 400V-50Hz-133A
171	175U1145	Capacitor Bank AHF3 DA/B 400V-50Hz-171A
204	175U1146	Capacitor Bank AHF3 DA/B 400V-50Hz-204A
251	175U1147	Capacitor Bank AHF3 DA/B 400V-50Hz-251A
304	175U1148	Capacitor Bank AHF3 DA/B 400V-50Hz-304A
325	175U1149	Capacitor Bank AHF3 DA/B 400V-50Hz-325A

Table 63: Capacitor Kits, 380–415 V, 50 Hz - (continued)

380–415 V, 50 Hz	Capacitor kit	
Current rating [A]	Code number [P/N]	Description
381	175U1150	Capacitor Bank AHF3 DA/B 400V-50Hz-381A
480	175U1151	Capacitor Bank AHF3 DA/B 400V-50Hz-480A

Table 64: Capacitor Kits, 380–415 V, 60 Hz

380–415 V, 60 Hz	Capacitor kit	
Current rating [A]	Code number [P/N]	Description
10	175U1152	Capacitor Bank AHF3 DA/B 380/460V-60Hz-010/010A
14	175U1153	Capacitor Bank AHF3 DA/B 380/460V-60Hz-014/014A
22	175U1154	Capacitor Bank AHF3 DA/B 380/460V-60Hz-022/019A
29	175U1155	Capacitor Bank AHF3 DA/B 380/460V-60Hz-029/025A
34	175U1156	Capacitor Bank AHF3 DA/B 380/460V-60Hz-034/031A
40	175U1158	Capacitor Bank AHF3 DA/B 380/460V-60Hz-040/036A
55	175U1159	Capacitor Bank AHF3 DA/B 380/460V-60Hz-055/048A
66	175U1160	Capacitor Bank AHF3 DA/B 380/460V-60Hz-066/060A
82	175U1161	Capacitor Bank AHF3 DA/B 380/460V-60Hz-082/073A
96	175U1162	Capacitor Bank AHF3 DA/B 380/460V-60Hz-096/095A
133	175U1163	Capacitor Bank AHF3 DA/B 380/460V-60Hz-133/118A
171	175U1164	Capacitor Bank AHF3 DA/B 380/460V-60Hz-171/154A
204	175U1165	Capacitor Bank AHF3 DA/B 380/460V-60Hz-204/183A
251	175U1166	Capacitor Bank AHF3 DA/B 380/460V-60Hz-251/231A
304	175U1167	Capacitor Bank AHF3 DA/B 380/460V-60Hz-304/291A
325	175U1168	Capacitor Bank AHF3 DA/B 380/460V-60Hz-325/355A
381	175U1169	Capacitor Bank AHF3 DA/B 380/460V-60Hz-381/380A
480	175U1170	Capacitor Bank AHF3 DA/B 380/460V-60Hz-480/436A

Table 65: Capacitor Kits, 440–480 V, 60 Hz

440–480 V, 60 Hz	Capacitor kit	
Current rating [A]	Code number [P/N]	Description
10	175U1152	Capacitor Bank AHF3 DA/B 380/460V-60Hz-010/010A
14	175U1153	Capacitor Bank AHF3 DA/B 380/460V-60Hz-014/014A
19	175U1154	Capacitor Bank AHF3 DA/B 380/460V-60Hz-022/019A
25	175U1155	Capacitor Bank AHF3 DA/B 380/460V-60Hz-029/025A
31	175U1156	Capacitor Bank AHF3 DA/B 380/460V-60Hz-034/031A
36	175U1158	Capacitor Bank AHF3 DA/B 380/460V-60Hz-040/036A
48	175U1159	Capacitor Bank AHF3 DA/B 380/460V-60Hz-055/048A
60	175U1160	Capacitor Bank AHF3 DA/B 380/460V-60Hz-066/060A
73	175U1161	Capacitor Bank AHF3 DA/B 380/460V-60Hz-082/073A
95	175U1162	Capacitor Bank AHF3 DA/B 380/460V-60Hz-096/095A
118	175U1163	Capacitor Bank AHF3 DA/B 380/460V-60Hz-133/118A
154	175U1164	Capacitor Bank AHF3 DA/B 380/460V-60Hz-171/154A
183	175U1165	Capacitor Bank AHF3 DA/B 380/460V-60Hz-204/183A
231	175U1166	Capacitor Bank AHF3 DA/B 380/460V-60Hz-251/231A
291	175U1167	Capacitor Bank AHF3 DA/B 380/460V-60Hz-304/291A
355	175U1168	Capacitor Bank AHF3 DA/B 380/460V-60Hz-325/355A
380	175U1169	Capacitor Bank AHF3 DA/B 380/460V-60Hz-381/380A
436	175U1170	Capacitor Bank AHF3 DA/B 380/460V-60Hz-480/436A

Table 66: Capacitor Kits, 600 V, 60 Hz

600 V, 60 Hz	Capacitor kit	
Current rating [A]	Code number [P/N]	Description
15	175U1205	Capacitor Bank AHF3 DA/B 600V-60Hz-015A
20	175U1206	Capacitor Bank AHF3 DA/B 600V-60Hz-020A
24	175U1207	Capacitor Bank AHF3 DA/B 600V-60Hz-024A
29	175U1208	Capacitor Bank AHF3 DA/B 600V-60Hz-029A
36	175U1209	Capacitor Bank AHF3 DA/B 600V-60Hz-036A
50	175U1211	Capacitor Bank AHF3 DA/B 600V-60Hz-050A
58	175U1212	Capacitor Bank AHF3 DA/B 600V-60Hz-058A
77	175U1213	Capacitor Bank AHF3 DA/B 600V-60Hz-077A
87	175U1214	Capacitor Bank AHF3 DA/B 600V-60Hz-087A
109	175U1215	Capacitor Bank AHF3 DA/B 600V-60Hz-109A
128	175U1217	Capacitor Bank AHF3 DA/B 600V-60Hz-128A
155	175U1218	Capacitor Bank AHF3 DA/B 600V-60Hz-155A
197	175U1219	Capacitor Bank AHF3 DA/B 600V-60Hz-197A
240	175U1245	Capacitor Bank AHF3 DA/B 600V-60Hz-240A

Table 66: Capacitor Kits, 600 V, 60 Hz - (continued)

600 V, 60 Hz	Capacitor kit	
Current rating [A]	Code number [P/N]	Description
296	175U1254	Capacitor Bank AHF3 DA/B 600V-60Hz-296A
366	175U1255	Capacitor Bank AHF3 DA 600V-60Hz-366A
395	175U1256	Capacitor Bank AHF3 DA 600V-60Hz-395A

Table 67: Capacitor Kits, 500–690 V, 50 Hz

500–690 V, 50 Hz	Capacitor kit	
Current rating [A]	Code number [P/N]	Description
15	175U1173	Capacitor Bank AHF3 DA/B 690V-50Hz-015A
20	175U1174	Capacitor Bank AHF3 DA/B 690V-50Hz-020A
24	175U1175	Capacitor Bank AHF3 DA/B 690V-50Hz-024A
29	175U1176	Capacitor Bank AHF3 DA/B 690V-50Hz-029A
36	175U1177	Capacitor Bank AHF3 DA/B 690V-50Hz-036A
50	175U1178	Capacitor Bank AHF3 DA/B 690V-50Hz-050A
58	175U1180	Capacitor Bank AHF3 DA/B 690V-50Hz-058A
77	175U1190	Capacitor Bank AHF3 DA/B 690V-50Hz-077A
87	175U1193	Capacitor Bank AHF3 DA/B 690V-50Hz-087A
109	175U1195	Capacitor Bank AHF3 DA/B 690V-50Hz-109A
128	175U1196	Capacitor Bank AHF3 DA/B 690V-50Hz-128A
155	175U1197	Capacitor Bank AHF3 DA/B 690V-50Hz-155A
197	175U1198	Capacitor Bank AHF3 DA/B 690V-50Hz-197A
240	175U1199	Capacitor Bank AHF3 DA/B 690V-50Hz-240A
296	175U1201	Capacitor Bank AHF3 DA/B 690V-50Hz-296A
366	175U1202	Capacitor Bank AHF3 DA 690V-50Hz-366A
395	175U1203	Capacitor Bank AHF3 DA 690V-50Hz-395A

8.2.2 Terminal Kits

Items supplied, terminal kits:

- Terminal X1–X2: Each kit contains 3 terminal blocks, including labels for matching designations.
- Terminal X3–X4: Each kit contains 3 terminal blocks, including labels for matching designations.
- Terminal A+B: Each kit contains 3 terminal blocks, including labels for matching designations.

The spare part terminal kits are valid for revisions 01, 02, and 03, and support the following filter programs:

- VLT® Advanced Harmonic Filter AHF 005
- VLT® Advanced Harmonic Filter AHF 010

Table 68: Terminal Kits, 380–415 V, 50 Hz and 60 Hz

380–415 V, 50 Hz & 60 Hz	Terminals X1+X2		Terminals X3+X4		Terminals A+B	
	Current rating [A]	Code number [P/ N]	Description [Mains supply]	Code number [P/ N]	Description [Capacitor dis- connect]	Code number [P/ N]
10	175U0258	3 x 6 mm ²	175U0257	3 x 2.5 mm ²	175U0257	3 x 2.5 mm ²
14	175U0258	3 x 6 mm ²	175U0257	3 x 2.5 mm ²	175U0257	3 x 2.5 mm ²
22	175U0259	3 x 10 mm ²	175U0257	3 x 2.5 mm ²	175U0257	3 x 2.5 mm ²
29	175U0259	3 x 10 mm ²	175U0257	3 x 2.5 mm ²	175U0257	3 x 2.5 mm ²
34	175U0260	3 x 16 mm ²	175U0259	3 x 10 mm ²	175U0257	3 x 2.5 mm ²
40	175U0260	3 x 16 mm ²	175U0259	3 x 10 mm ²	175U0257	3 x 2.5 mm ²
55	175U0260	3 x 16 mm ²	175U0259	3 x 10 mm ²	175U0257	3 x 2.5 mm ²
66	175U0261	3 x 35 mm ²	175U0260	3 x 16 mm ²	175U0257	3 x 2.5 mm ²
82	175U0261	3 x 35 mm ²	175U0260	3 x 16 mm ²	175U0257	3 x 2.5 mm ²
96	175U0262	3 x 50 mm ²	175U0260	3 x 16 mm ²	175U0257	3 x 2.5 mm ²
133	175U0262	3 x 50 mm ²	175U0260	3 x 16 mm ²	175U0257	3 x 2.5 mm ²
171	175U0263	3 x 70 mm ²	175U0261	3 x 35 mm ²	175U0257	3 x 2.5 mm ²
204	175U0263	3 x 70 mm ²	175U0261	3 x 35 mm ²	175U0257	3 x 2.5 mm ²
251	175U0265	3 x 300 mm ²	175U0264	3 x 95/120 mm ²	175U0257	3 x 2.5 mm ²
304	175U0265	3 x 300 mm ²	175U0264	3 x 95/120 mm ²	175U0257	3 x 2.5 mm ²
325	175U0265	3 x 300 mm ²	175U0264	3 x 95/120 mm ²	175U0257	3 x 2.5 mm ²
381	175U0265	3 x 300 mm ²	175U0264	3 x 95/120 mm ²	175U0257	3 x 2.5 mm ²
480	175U0265	3 x 300 mm ²	175U0264	3 x 95/120 mm ²	175U0257	3 x 2.5 mm ²

Table 69: Terminal Kits, 440–480 V 60 Hz

440–480 V, 60 Hz	Terminals X1+X2		Terminals X3+X4		Terminals A+B	
	Current rating [A]	Code number [P/N]	Description [Mains supply]	Code number [P/N]	Description [Capacitor disconnect]	Code number [P/N]
10	175U0258	3 x 6 mm ²	175U0257	3 x 2.5 mm ²	175U0257	3 x 2.5 mm ²
14	175U0258	3 x 6 mm ²	175U0257	3 x 2.5 mm ²	175U0257	3 x 2.5 mm ²
19	175U0259	3 x 10 mm ²	175U0257	3 x 2.5 mm ²	175U0257	3 x 2.5 mm ²
25	175U0259	3 x 10 mm ²	175U0257	3 x 2.5 mm ²	175U0257	3 x 2.5 mm ²
31	175U0260	3 x 16 mm ²	175U0259	3 x 10 mm ²	175U0257	3 x 2.5 mm ²
36	175U0260	3 x 16 mm ²	175U0259	3 x 10 mm ²	175U0257	3 x 2.5 mm ²
48	175U0260	3 x 16 mm ²	175U0259	3 x 10 mm ²	175U0257	3 x 2.5 mm ²
60	175U0261	3 x 35 mm ²	175U0260	3 x 16 mm ²	175U0257	3 x 2.5 mm ²
73	175U0261	3 x 35 mm ²	175U0260	3 x 16 mm ²	175U0257	3 x 2.5 mm ²
95	175U0262	3 x 50 mm ²	175U0260	3 x 16 mm ²	175U0257	3 x 2.5 mm ²
118	175U0262	3 x 50 mm ²	175U0260	3 x 16 mm ²	175U0257	3 x 2.5 mm ²
154	175U0263	3 x 70 mm ²	175U0261	3 x 35 mm ²	175U0257	3 x 2.5 mm ²
183	175U0263	3 x 70 mm ²	175U0261	3 x 35 mm ²	175U0257	3 x 2.5 mm ²
231	175U0265	3 x 300 mm ²	175U0264	3 x 95/120 mm ²	175U0257	3 x 2.5 mm ²
291	175U0265	3 x 300 mm ²	175U0264	3 x 95/120 mm ²	175U0257	3 x 2.5 mm ²
355	175U0265	3 x 300 mm ²	175U0264	3 x 95/120 mm ²	175U0257	3 x 2.5 mm ²
380	175U0265	3 x 300 mm ²	175U0264	3 x 95/120 mm ²	175U0257	3 x 2.5 mm ²
436	175U0265	3 x 300 mm ²	175U0264	3 x 95/120 mm ²	175U0257	3 x 2.5 mm ²

Table 70: Terminal Kits, 600 V 60 Hz

600 V, 60 Hz Current rating [A]	Terminals X1+X2		Terminals X3+X4		Terminals A+B	
	Code number [P/ N]	Description [Mains supply]	Code number [P/ N]	Description [Capacitor dis- connect]	Code number [P/ N]	Description [Thermal switch]
15	175U0260	3 x 16 mm ²	175U0259	3 x 10 mm ²	175U0257	3 x 2.5 mm ²
20	175U0260	3 x 16 mm ²	175U0259	3 x 10 mm ²	175U0257	3 x 2.5 mm ²
24	175U0261	3 x 35 mm ²	175U0260	3 x 16 mm ²	175U0257	3 x 2.5 mm ²
29	175U0261	3 x 35 mm ²	175U0260	3 x 16 mm ²	175U0257	3 x 2.5 mm ²
36	175U0261	3 x 35 mm ²	175U0260	3 x 16 mm ²	175U0257	3 x 2.5 mm ²
50	175U0262	3 x 50 mm ²	175U0260	3 x 16 mm ²	175U0257	3 x 2.5 mm ²
58	175U0262	3 x 50 mm ²	175U0260	3 x 16 mm ²	175U0257	3 x 2.5 mm ²
77	175U0263	3 x 70 mm ²	175U0261	3 x 35 mm ²	175U0257	3 x 2.5 mm ²
87	175U0263	3 x 70 mm ²	175U0261	3 x 35 mm ²	175U0257	3 x 2.5 mm ²
109	175U0263	3 x 70 mm ²	175U0261	3 x 35 mm ²	175U0257	3 x 2.5 mm ²
128	175U0263	3 x 70 mm ²	175U0261	3 x 35 mm ²	175U0257	3 x 2.5 mm ²
155	175U0265	3 x 300 mm ²	175U0264	3 x 95/120 mm ²	175U0257	3 x 2.5 mm ²
197	175U0265	3 x 300 mm ²	175U0264	3 x 95/120 mm ²	175U0257	3 x 2.5 mm ²
240	175U0265	3 x 300 mm ²	175U0264	3 x 95/120 mm ²	175U0257	3 x 2.5 mm ²
296	175U0265	3 x 300 mm ²	175U0264	3 x 95/120 mm ²	175U0257	3 x 2.5 mm ²
366	175U0265	3 x 300 mm ²	175U0264	3 x 95/120 mm ²	175U0257	3 x 2.5 mm ²
395	175U0265	3 x 300 mm ²	175U0264	3 x 95/120 mm ²	175U0257	3 x 2.5 mm ²

Table 71: Terminal Kits, 500–690 V 50 Hz

500–690 V, 50 Hz	Terminals X1+X2		Terminals X3+X4		Terminals A+B	
	Current rating [A]	Code number [P/N]	Description [Mains supply]	Code number [P/N]	Description [Capacitor disconnect]	Code number [P/N]
15	175U0260	3 x 16 mm ²	175U0259	3 x 10 mm ²	175U0257	3 x 2.5 mm ²
20	175U0260	3 x 16 mm ²	175U0259	3 x 10 mm ²	175U0257	3 x 2.5 mm ²
24	175U0261	3 x 35 mm ²	175U0260	3 x 16 mm ²	175U0257	3 x 2.5 mm ²
29	175U0261	3 x 35 mm ²	175U0260	3 x 16 mm ²	175U0257	3 x 2.5 mm ²
36	175U0261	3 x 35 mm ²	175U0260	3 x 16 mm ²	175U0257	3 x 2.5 mm ²
50	175U0262	3 x 50 mm ²	175U0260	3 x 16 mm ²	175U0257	3 x 2.5 mm ²
58	175U0262	3 x 50 mm ²	175U0260	3 x 16 mm ²	175U0257	3 x 2.5 mm ²
77	175U0263	3 x 70 mm ²	175U0261	3 x 35 mm ²	175U0257	3 x 2.5 mm ²
87	175U0263	3 x 70 mm ²	175U0261	3 x 35 mm ²	175U0257	3 x 2.5 mm ²
109	175U0263	3 x 70 mm ²	175U0261	3 x 35 mm ²	175U0257	3 x 2.5 mm ²
128	175U0263	3 x 70 mm ²	175U0261	3 x 35 mm ²	175U0257	3 x 2.5 mm ²
155	175U0265	3 x 300 mm ²	175U0264	3 x 95/120 mm ²	175U0257	3 x 2.5 mm ²
197	175U0265	3 x 300 mm ²	175U0264	3 x 95/120 mm ²	175U0257	3 x 2.5 mm ²
240	175U0265	3 x 300 mm ²	175U0264	3 x 95/120 mm ²	175U0257	3 x 2.5 mm ²
296	175U0265	3 x 300 mm ²	175U0264	3 x 95/120 mm ²	175U0257	3 x 2.5 mm ²
366	175U0265	3 x 300 mm ²	175U0264	3 x 95/120 mm ²	175U0257	3 x 2.5 mm ²
395	175U0265	3 x 300 mm ²	175U0264	3 x 95/120 mm ²	175U0257	3 x 2.5 mm ²

8.2.3 Fan and Fan Accessories, Revisions 01 and 02

Items supplied, fan kits and fan accessories:

- Fan: the spare part fan kit contains 1 fan.
- Fan fence: the spare part fan fence kit contains 1 fence.
- Transformer: the spare part transformer kit contains 1 transformer.

The spare part fan kits support:

- VLT® Advanced Harmonic Filter AHF 005
- VLT® Advanced Harmonic Filter AHF 010

NOTICE

The spare part kits are designed individually for revision numbers 01, 02, and 03.

Table 72: Fan Kits and Accessories, 380–415 V, 50 Hz and 60 Hz

380–415 V, 50 Hz & 60 Hz	Fan			Fan fence			Fan transformer			
	Current rating [A]	Items required [Pcs]	Code number [P/N]	Description	Items required [Pcs]	Code number [P/N]	Description	Items required [Pcs]	Code number [P/N]	Description
10	0	–	(1)	1	175U0113	AHF2 Fan fence size 10	0	–	(1)	
14	1	175U0110	AHF2 Fan 380–400 V 10–29 A	1	175U0113		AHF2 Fan fence size 10	1	175U0268	Transformer for AHF2 400 V/460 V–230 V
22	1			1				1		
29	1			1				1		
34	1	175U0111	AHF2 Fan 380–400 V 34–480 A/460 V 1–436 A	1	175U0112	AHF2 Fan fence size 20	1	175U0267	Transformer for AHF2 400 V–2x230 V	
40	1			1			1			
55	1			1			1			
66	1			1			1			
82	1			1			1			
96	1			1			1			
133	1			1			1			
171	1			1			1			
204	1			1			1			
251	2			2			2			
304	2			2			2			
325	2			2			2			
381	2	2	2							
480	2	2	2							

1) 10 A version is cooled by natural convections and has no fan.

Table 73: Fan Kits and Accessories, 440–480 V, 60 Hz

440–480 V, 60 Hz	Fan			Fan fence			Fan transformer			
	Current rating [A]	Items required [Pcs]	Code number [P/N]	Description	Items required [Pcs]	Code number [P/N]	Description	Items required [Pcs]	Code number [P/N]	Description
10	0	–	(1)	1	175U0113	AHF2 Fan fence size 10	0	–	(1)	
14	1	175U0110	AHF2 Fan 380–400 V 10–29 A	1	175U0113	AHF2 Fan fence size 10	1	175U0268	Transformer for AHF2 400 V/460 V–230 V	
19	1			1			1			
25	1			1			1			
31	1	175U0111	AHF2 Fan 380–400 V 34–480 A/460 V 10–436 A	1	175U0112	AHF2 Fan fence size 20	1			
36	1			1			1			
48	1			1			1			
60	1			1			1			
73	1			1			1			
95	1			1			1			
118	1			1			1			
154	1			1			1			
183	1			1			1			
231	2			2			2			
291	2			2			2			
355	2			2			2			
380	2			2			2			
436	2			2			2			

1) 10 A version is cooled by natural convections and has no fan.

Table 74: Fan Kits and Accessories, 600 V, 60 Hz

600 V, 60 Hz		Fan		Fan fence			Fan transformer		
Current rating [A]	Items required [Pcs]	Code number [P/N]	Description	Items required [Pcs]	Code number [P/N]	Description	Items required [Pcs]	Code number [P/N]	Description
15	1	175U0111	AHF2 Fan 380–400 V 34–480 A/460 V 10–436 A	1	175U0112	AHF2 Fan fence size 20	1	175U0269	Transformer for AHF2 600 V/690 V–230 V
20	1			1			1		
24	1			1			1		
29	1			1			1		
36	1			1			1		
50	1			1			1		
58	1			1			1		
77	1			1			1		
87	1			1			1		
109	1			1			1		
128	1			1			1		
155	2			2			2		
197	2			2			2		
240	2			2			2		
296	2			2			2		
366	2			2			2		
395	2			2			2		

Table 75: Fan Kits and Accessories, 500–690 V, 50 Hz

500–690 V, 50 Hz	Fan			Fan fence			Fan transformer		
Current rating [A]	Items required [Pcs]	Code number [P/N]	Description	Items required [Pcs]	Code number [P/N]	Description	Items required [Pcs]	Code number [P/N]	Description
15	1	175U0266	AHF2 Fan 600–690 V	1	175U0323	AHF2 Fan fence size 30	1	175U0269	Transformer for AHF2 600 V/690 V–230 V
20	1			1					
24	1			1					
29	1			1					
36	1			1					
50	1			1					
58	1			1					
77	1			1					
87	1			1					
109	1			1					
128	1			1					
155	2			2					
197	2			2					
240	2			2					
296	2			2					
366	2			2					
395	2	2							

8.2.4 Fan and Fan Accessories for Revision 03

Items supplied, fan kits and accessories:

- Fan: the spare part fan kit contains 1 fan.
- Fan fence: the spare part fan fence kit contains 1 fence. Enclosures with integrated fan (internal fan) have no separate fan fence.
- Transformer: the spare part transformer kit contains 1 transformer.

The spare part fan kits support:

- VLT® Advanced Harmonic Filter AHF 005.
- VLT® Advanced Harmonic Filter AHF 010.

NOTICE

The spare part kits are designed individually for the revision numbers 01, 02, and 03.

Table 76: Fan Kits and Accessories for AHF 005, 380–415 V, 50 Hz

380–415 V/50 Hz AHF 005		Fan			Fan fence			Fan control				
Current rating [A]	Enclosure type ⁽¹⁾	Items required [Pcs]	Code number [P/N]	Description	Items required [Pcs]	Code number [P/N]	Description	Items required [Pcs]	Code number [P/N]	Description		
10	X1-V3 IP20 if	0	–	⁽²⁾	0	–	–	0	–	–		
14	X1-V3 IP20 ef	1	175U0338	AHF3 fan 24 V DC	1	175U0339	AHF3 fan fence for 24 V DC fan	1	175U0337	AHF3 fan control for 24 V DC fan		
22	X2-V3 IP20 ef	1			1			1				
29	X2-V3 IP20 ef	1			1			1				
34	X3-V3 IP20 if	1			0			–			–	1
40	X3-V3 IP20 if	1			0			–			–	1
55	X3-V3 IP20 if	1			0			–			–	1
66	X4-V3 IP20 if	1			0			–			–	1
82	X4-V3 IP20 ef	1			1	175U0339	AHF3 fan fence for 24 V DC fan	1				
96	X5-V3 IP20 ef	1			1			1				
133	X5-V3 IP20 ef	1			1			1				
171	X6-V3 IP20 ef	1			1			1				
204	X6-V3 IP20 ef	1			1			1				
251	X7-V3 IP20 if	2			0	–	–	1				
304	X7-V3 IP20 if	2			0	–	–	1				
325	X8-V3 IP20 if	2			0	–	–	1				
381	X8-V3 IP20 ef	2			2	175U0339	AHF3 fan fence for 24 V DC fan	1				
480	X8-V3 IP20 ef	2			2			1				

1) Enclosure types with internal fan have fan fence integrated in cabinet.

2) 10 A version is cooled by natural convections and contains no fan.

Table 77: Fan Kits and Accessories for AHF 010, 380–415 V, 50 Hz

380–415 V/50 Hz, AHF 010		Fan			Fan fence			Fan control				
Current rating [A]	Enclosure type ⁽¹⁾	Items required [Pcs]	Code number [P/N]	Description	Items required [Pcs]	Code number [P/N]	Description	Items required [Pcs]	Code number [P/N]	Description		
10	X1-V3 IP20 if	0	–	⁽²⁾	0	–	–	0	–	–		
14	X1-V3 IP20 ef	1	175U033 8	AHF3 fan 24 V DC	1	175U033 9	AHF3 fan fence for 24 V DC fan	1	175U033 7	AHF3 fan control for 24 V DC fan		
22	X2-V3 IP20 if	1			0			–			–	1
29	X2-V3 IP20 if	1			0			–			–	1
34	X3-V3 IP20 if	1			0			–			–	1
40	X3-V3 IP20 if	1			0			–			–	1
55	X3-V3 IP20 if	1			0			–			–	1
66	X4-V3 IP20 if	1			0			–			–	1
82	X4-V3 IP20 ef	1			1			175U033 9			AHF3 fan fence for 24 V DC fan	1
96	X5-V3 IP20 ef	1			1							1
133	X5-V3 IP20 ef	1			1							1
171	X6-V3 IP20 if	1			0			–			–	1
204	X6-V3 IP20 if	1			0			–			–	1
251	X7-V3 IP20 if	2			0			–			–	1
304	X7-V3 IP20 if	2			0			–			–	1
325	X7-V3 IP20 if	2			0			–			–	1
381	X7-V3 IP20 if	2			0			–			–	1
480	X8-V3 IP20 ef	2	2	175U033 9	AHF3 fan fence for 24 V DC fan	1						

1) Enclosure types with internal fan have fan fence integrated in cabinet.

2) 10 A version is cooled by natural convections and contains no fan.

Table 78: Fan Kits and Accessories for AHF 005, 380–415 V, 60 Hz

380–415 V/60 Hz AHF 005		Fan			Fan fence			Fan control			
Current rating [A]	Enclosure type ⁽¹⁾	Items required [Pcs]	Code number [P/N]	Description	Items required [Pcs]	Code number [P/N]	Description	Items required [Pcs]	Code number [P/N]	Description	
10	X1-V3 IP20 if	0	–	⁽²⁾	0	–	–	0	–	–	
14	X1-V3 IP20 ef	1	175U0338	AHF3 fan 24 V DC	1	175U0339	AHF3 fan fence for 24 V DC fan	1	175U0337	AHF3 fan control for 24 V DC fan	
22	X2-V3 IP20 ef	1			1			1			
29	X2-V3 IP20 ef	1			1			1			
34	X3-V3 IP20 if	1	175U0338	AHF3 fan 24 V DC	0	–	–	1	–	–	
40	X3-V3 IP20 if	1			0			1			
55	X3-V3 IP20 if	1			0			1			
66	X4-V3 IP20 if	1			0			1			
82	X4-V3 IP20 ef	1			1	175U0339	AHF3 fan fence for 24 V DC fan	1			1
96	X5-V3 IP20 ef	1			1			1			
133	X5-V3 IP20 ef	1			1			1			
171	X6-V3 IP20 ef	1			1			1			
204	X6-V3 IP20 ef	1			1			1			
251	X7-V3 IP20 if	2			0	–	–	1			1
304	X8-V3 IP20 if	2			0			1			
325	X8-V3 IP20 ef	2			0			1			
381	X8-V3 IP20 ef	2			2	175U0339	AHF3 fan fence for 24 V DC fan	1			1
480	X8-V3 IP20 ef	2	2	1							

1) Enclosure types with internal fan have fan fence integrated in cabinet.

2) 10 A version is cooled by natural convections and contains no fan.

Table 79: Fan Kits and Accessories for AHF 010, 380–415 V, 60 Hz

380–415 V/60 Hz AHF 010		Fan			Fan fence			Fan control				
Current rating [A]	Enclosure type ⁽¹⁾	Items required [Pcs]	Code number [P/N]	Description	Items required [Pcs]	Code number [P/N]	Description	Items required [Pcs]	Code number [P/N]	Description		
10	X1-V3IP20 if	0	–	⁽²⁾	0	–	–	0	–	–		
14	X1-V3IP20 ef	1	175U0338	AHF3 fan 24 V DC	1	175U0339	AHF3 fan fence for 24 V DC fan	1	175U0337	AHF3 fan control for 24 V DC fan		
22	X2-V3IP20 if	1			0			–			–	1
29	X2-V3IP20 if	1			0			–			–	1
34	X3-V3IP20 if	1			0			–			–	1
40	X3-V3IP20 if	1			0			–			–	1
55	X3-V3IP20 if	1			0			–			–	1
66	X4-V3IP20 if	1			0			–			–	1
82	X4-V3IP20 ef	1			1			175U0339			AHF3 fan fence for 24 V DC fan	1
96	X5-V3IP20 ef	1			1			–			–	1
133	X5-V3IP20 ef	1			1			–			–	1
171	X6-V3IP20 if	1			0			–			–	1
204	X6-V3IP20 if	1			0			–			–	1
251	X7-V3IP20 if	2			0			–			–	2
304	X7-V3IP20 if	2			0			–			–	1
325	X7-V3IP20 ef	2			2			175U0339			AHF3 fan fence for 24 V DC fan	2
381	X7-V3IP20 ef	2			2			–			–	2
480	X8-V3IP20 ef	2	2	–	–	2						

1) Enclosure types with internal fan have fan fence integrated in cabinet.

2) 10 A version is cooled by natural convections and contains no fan.

Table 80: Fan Kits and Accessories for AHF 005, 440–480 V, 60 Hz

440–480 V/60 Hz, AHF 005		Fan			Fan fence			Fan control				
Current rating [A]	Enclosure type ⁽¹⁾	Items required [Pcs]	Code number [P/N]	Description	Items required [Pcs]	Code number [P/N]	Description	Items required [Pcs]	Code number [P/N]	Description		
10	X1-V3 IP20 if	0	–	⁽²⁾	0	–	–	0	–	–		
14	X1-V3IP20 ef	1	175U0338	AHF3 fan 24 V DC	1	175U0339	AHF3 fan fence for 24 V DC fan	1	175U0337	AHF3 fan control for 24 V DC fan		
19	X2-V3IP20 ef	1			1							
25	X2-V3IP20 ef	1			1							
31	X3-V3IP20 if	1			0			–			–	1
36	X3-V3IP20 if	1			0			–			–	1
48	X3-V3IP20 if	1			0			–			–	1
60	X4-V3IP20 if	1			0			–			–	1
73	X4-V3IP20 ef	1			1			175U0339			AHF3 fan fence for 24 V DC fan	1
95	X5-V3IP20 ef	1			1	1						
118	X5-V3IP20 ef	1			1	1						
154	X6-V3IP20 ef	1			1	1						
183	X6-V3IP20 ef	1			1	1						
231	X7-V3IP20 if	2			0	–	–					2
291	X8-V3IP20 if	2			0	–	–	2				
355	X8-V3IP20 ef	2			2	175U0339	AHF3 fan fence for 24 V DC fan	2				
380	X8-V3IP20 ef	2			2			2				
436	X8-V3IP20 ef	2	2	2								

1) Enclosure types with internal fan have fan fence integrated in cabinet.

2) 10 A version is cooled by natural convections and contains no fan.

Table 81: Fan Kits and Accessories for AHF 010, 440–480 V, 60 Hz

440–480 V/60 Hz, AHF 010		Fan			Fan fence			Fan control				
Current rating [A]	Enclosure type ⁽¹⁾	Items required [Pcs]	Code number [P/N]	Description	Items required [Pcs]	Code number [P/N]	Description	Items required [Pcs]	Code number [P/N]	Description		
10	X1-V3IP20 if	0	–	(2)	0	–	–	0	–	–		
14	X1-V3IP20 ef	1	175U0338	AHF3 fan 24 V DC	1	175U0339	AHF3 fan fence for 24 V DC fan	1	175U0337	AHF3 fan control for 24 V DC fan		
19	X2-V3IP20 if	1			0			–			–	1
25	X2-V3IP20 if	1			0			–			–	1
31	X3-V3IP20 if	1			0			–			–	1
36	X3-V3IP20 if	1			0			–			–	1
48	X3-V3IP20 if	1			0			–			–	1
60	X4-V3IP20 if	1			0			–			–	1
73	X4-V3IP20 ef	1			1			175U0339			AHF3 fan fence for 24 V DC fan	1
95	X5-V3IP20 ef	1			1							1
118	X5-V3IP20 ef	1			1							1
154	X6-V3IP20 if	1			0			–			–	1
183	X6-V3IP20 if	1			0			–			–	1
231	X7-V3IP20 if	2			0			–			–	2
291	X7-V3IP20 if	2			0			–			–	2
355	X7-V3IP20 ef	2	2	175U0339	AHF3 fan fence for 24 V DC fan	2						
380	X7-V3IP20 ef	2	2			2						
436	X8-V3IP20 ef	2	2			2						

1) Enclosure types with internal fan have fan fence integrated in cabinet.

2) 10 A version is cooled by natural convections and contains no fan.

Table 82: Fan Kits and Accessories for AHF 005, 600 V, 60 Hz

600 V/60 Hz, AHF 005		Fan			Fan fence			Fan control			Fan transformer			
Current rating [A]	Enclosure type ⁽¹⁾	Items required [Pcs]	Code number [P/N]	Description	Items required [Pcs]	Code number [P/N]	Description	Items required [Pcs]	Code number [P/N]	Description	Items required [Pcs]	Code number [P/N]	Description	
15	X3-V3 IP20 if	1	175U0338	AHF3 fan 24 V DC	0	-	-	1	175U0337	AHF3 fan control for 24 V DC fan	1	175U0328	AHF3 Transformer for Fan Controller	
20	X3-V3 IP20 if	1			0	-	-	1			1			
24	X3-V3 IP20 ef	1			1	175U0339	AHF3 fan fence for 24 V DC fan	1			1			1
29	X4-V3 IP20 ef	1			1			1			1			
36	X4-V3 IP20 ef	1			1			1			1			
50	X5-V3 IP20 ef	1			1			1			1			
58	X5-V3 IP20 ef	1			1			1			1			
77	X6-V3 IP20 ef	1			1			1			1			
87	X6-V3 IP20 ef	1			1			1			1			
109	X6-V3 IP20 ef	1			1			1			1			
128	X6-V3 IP20 ef	1			1			1			1			
155	X7-V3 IP20 ef	2			2			2			2			
197	X7-V3 IP20 ef	2			2	2	2							
240	X8-V3 IP20 ef	2			2	2	2							
296	X8-V3 IP20 ef	2	2	2	2									

1) Enclosure types with internal fan have fan fence integrated in cabinet.

Table 83: Fan Kits and Fan Fence Kits, AHF 010, 600 V, 60 Hz

600 V/60 Hz, AHF 010		Fan			Fan fence			Fan control			Fan transformer		
Current rating [A]	Enclosure type ¹⁾	Items required [Pcs]	Code number [P/N]	Description	Items required [Pcs]	Code number [P/N]	Description	Items required [Pcs]	Code number [P/N]	Description	Items required [Pcs]	Code number [P/N]	Description
15	X3-V3 IP20 if	1	175U0338	AHF3 fan 24 V DC	0	–	–	1	175U0337	AHF3 fan control for 24 V DC fan	1	175U0328	AHF3 Transformer for Fan Controller
20	X3-V3 IP20 if	1			0	–	–	1					
24	X3-V3 IP20 ef	1			1	175U0339	AHF3 fan fence for 24 V DC fan	1					
29	X4-V3 IP20 ef	1			1			1					
36	X4-V3 IP20 ef	1			1			1					
50	X5-V3 IP20 ef	1			1			1					
58	X5-V3 IP20 ef	1			1			1					
77	X6-V3 IP20 ef	1			1			1					
87	X6-V3 IP20 ef	1			1			1					
109	X6-V3 IP20 ef	1			1			1					
128	X6-V3 IP20 ef	1			1			1					
155	X7-V3 IP20 ef	2			2			2					
197	X7-V3 IP20 ef	2			2	2							
240	X7-V3 IP20 ef	2			2	2							
296	X8-V3 IP20 ef	2			2	2							
366	X8-V3 IP20 ef	2			2	2							
395	X8-V3 IP20 ef	2	2	2									

1) Enclosure types with internal fan have fan fence integrated in cabinet.

Table 84: Fan Kits and Accessories for AHF 005, 500–690 V, 50 Hz

500–690 V/50 Hz, AHF 005		Fan			Fan fence			Fan control			Fan transformer		
Current rating [A]	Enclosure type ⁽¹⁾	Items required [Pcs]	Code number [P/N]	Description	Items required [Pcs]	Code number [P/N]	Description	Items required [Pcs]	Code number [P/N]	Description	Items required [Pcs]	Code number [P/N]	Description
15	X3-V3 IP20 if	1	175U03 38	AHF3 fan 24 V DC	0	–	–	1	175U03 37	AHF3 fan control for 24 V DC fan	1	175U03 28	AHF3 Transformer for Fan Controller
20	X3-V3 IP20 if	1			0	–	–	1					
24	X3-V3 IP20 ef	1			1	175U03 39	AHF3 fan fence for 24 V DC fan	1	1	1			
29	X4-V3 IP20 ef	1			1			1	1				
36	X4-V3 IP20 ef	1			1			1	1				
50	X5-V3 IP20 ef	1			1			1	1				
58	X5-V3 IP20 ef	1			1			1	1				
77	X6-V3 IP20 ef	1			1			1	1				
87	X6-V3 IP20 ef	1			1			1	1				
109	X6-V3 IP20 ef	1			1			1	1				
128	X6-V3 IP20 ef	1			1			1	1				
155	X7-V3 IP20 ef	2			2			2	2				
197	X7-V3 IP20 ef	2			2	2	2						
240	X8-V3 IP20 ef	2			2	2	2						
296	X8-V3 IP20 ef	2	2	2	2								

1) Enclosure types with internal fan have fan fence integrated in cabinet.

Table 85: Fan Kits and Accessories for AHF 010, 500–690 V, 50 Hz

500–690 V/50 Hz, AHF 010		Fan			Fan fence			Fan control			Fan transformer		
Current rating [A]	Enclosure type ⁽¹⁾	Items required [Pcs]	Code number [P/N]	Description	Items required [Pcs]	Code number [P/N]	Description	Items required [Pcs]	Code number [P/N]	Description	Items required [Pcs]	Code number [P/N]	Description
15	X3-V3IP20if	1	175U0338	AHF3 fan 24V DC	0	–	–	1	175U0337	AHF3 fan control for 24 V DC fan	1	175U0328	AHF3 Transformer for Fan Controller
20	X3-V3IP20if	1			0	1							
24	X3-V3IP20ef	1			1	175U0339	AHF3 fan fence for 24 V DC fan	1					
29	X4-V3IP20ef	1			1			1					
36	X4-V3IP20ef	1			1			1					
50	X5-V3IP20ef	1			1			1					
58	X5-V3IP20ef	1			1			1					
77	X6-V3IP20ef	1			1			1					
87	X6-V3IP20ef	1			1			1					
109	X6-V3IP20ef	1			1			1					
128	X6-V3IP20ef	1			1			1					
155	X7-V3IP20ef	2			2			2					
197	X7-V3IP20ef	2			2	2							

Table 85: Fan Kits and Accessories for AHF 010, 500–690 V, 50 Hz - (continued)

500–690 V/50 Hz, AHF 010		Fan			Fan fence			Fan control			Fan transformer		
Current rating [A]	Enclosure type ⁽¹⁾	Items required [Pcs]	Code number [P/N]	Description	Items required [Pcs]	Code number [P/N]	Description	Items required [Pcs]	Code number [P/N]	Description	Items required [Pcs]	Code number [P/N]	Description
240	X7-V3IP20ef	2	175U0338	AHF3 fan 24V DC	2	175U0339	AHF3 fan fence for 24 V DC fan	2	175U0337	AHF3 fan control for 24 V DC fan	1	175U0328	AHF3 Transformer for Fan Controller
296	X8-V3IP20ef	2			2			2			1		
366	X8-V3IP20ef	2			2			2			1		
395	X8-V3IP20ef	2			2			2			1		

1) Enclosure types with internal fan have fan fence integrated in cabinet.

8.2.5 Fuses and Fuse Accessories

Fan fuses: the spare fuse kits contain 10 fuses.

The spare part fuse kits support the following filter programs;

- VLT® Advanced Harmonic Filter AHF 005.
- VLT® Advanced Harmonic Filter AHF 010.

NOTICE

The spare part kits are designed individually for the revision numbers 01, 02, and 03.

For spare parts for revision 01 and 02, see [Table 86](#).

For spare parts for revision 03, see [Table 87](#).

Table 86: Fuse Kits and Accessories, Valid for Revisions 01 and 02

380– 415 V, 50 Hz	380– 415 V, 60 Hz	440– 480 V, 60 Hz	600 V, 60 Hz	500– 690 V, 50 Hz	Fuse		Fuse holder		Fuse cover	
Current rating [A]					Code number [P/N]	Descrip- tion	Code number [P/N]	Descrip- tion	Code number [P/N]	Descrip- tion
10	10	10	–	–	(1)	(1)	(1)	(1)	(1)	(1)
14	14	14	15	15	175U0114	AHF Fuse for fan 380– 690V 2 A	175U0115	AHF Fuse holder 380–690V	175U0117	AHF Cover for fuse holder 380–690V
22	22	19	20	20						
29	29	25	24	24						
34	34	31	29	29						
40	40	36	36	36						
55	55	48	50	50						
66	66	60	58	58						
82	82	73	77	77						
96	96	95	87	87						
133	133	118	109	109						
171	171	154	128	128						
204	204	183	155	155						
251	251	231	197	197						
304	304	291	240	240						
325	325	355	296	296						
381	381	380	366	366						
480	480	436	395	395						

1) 10 A versions are cooled by natural convections and has no built-in fan.

Table 87: Fuse Kits and Accessories, Valid for Revision 03

380– 415 V, 50 Hz	380– 415 V, 60 Hz	440– 480 V, 60 Hz	600 V, 60 Hz	500– 690 V, 50 Hz	Fuse		Fuse holder		Fuse cover	
Current rating [A]					Code number [P/N]	Description	Code number [P/N]	Description	Code number [P/N]	Description
(1)			15	15	175U011 4	AHF Fuse for fan 380– 690V 2 A	175U011 5	AHF Fuse holder 380– 690V	175U011 7	AHF Cover for fuse holder 380– 690 V
			20	20						
			24	24						
(1)			29	29						
			36	36						
			50	50						
			58	58						
(1)			77	77						
			87	87						
			109	109						
			128	128						
(1)			155	155						
			197	197						
			240	240						
			296	296						
(1)			366	366						
			395	395						

1) No fuses - Fuses are only for 600 V and 690 V types utilizing an additional transformer in front of the fan control.

9 Appendix

9.1 Energy Efficiency

9.1.1 Introduction to Energy Efficiency

The standard *IEC 61800-9-2 Ecodesign for power drive systems* provides guidelines for assessing the energy efficiency of drives.

The standard provides a neutral method for determining efficiency classes and power losses at full load and at part load. The standard allows combination of any motor with any drive.

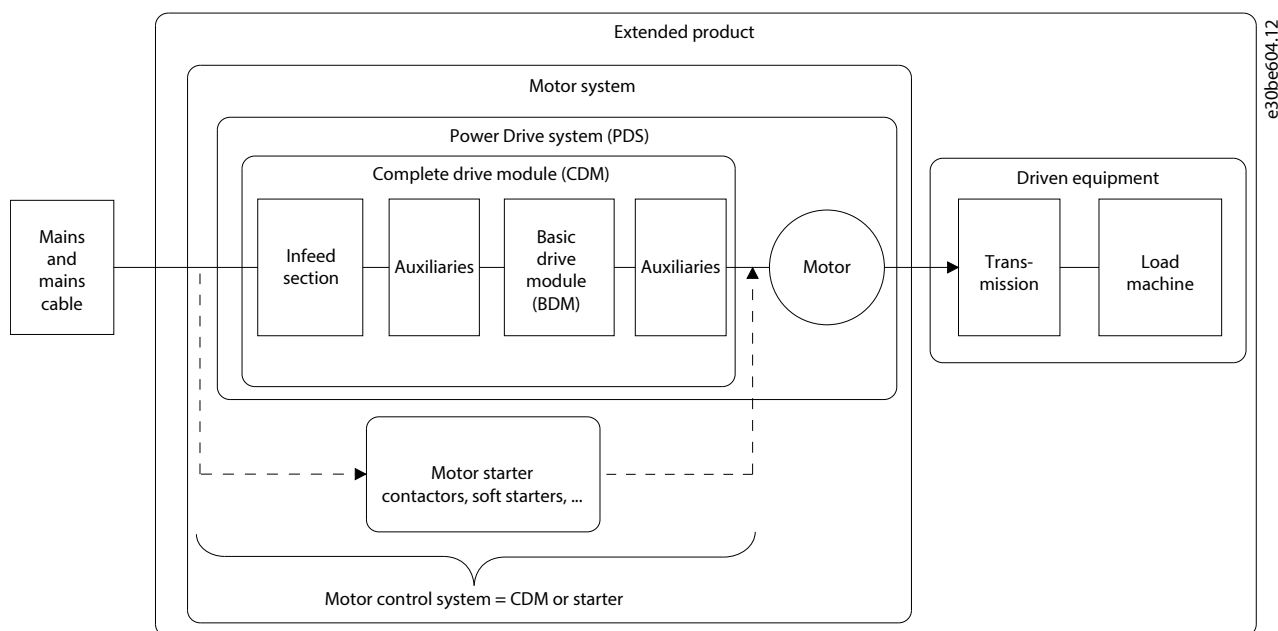

Figure 82: Power Drive System (PDS) and Complete Drive Module (CDM)

Auxiliaries:

- VLT® Advanced Harmonic Filter AHF 005
- VLT® Advanced Harmonic Filter AHF 010
- VLT® Line Reactor MCC 103
- VLT® Sine-wave Filter MCC 101
- VLT® dU/dt Filter MCC 102

9.1.2 IE and IES Classes

Complete drive module

According to the standard *IEC 61800-9-2*, the *Complete drive module* comprises the drive, its feeding section, and its auxiliaries.

Energy efficiency classes for the CDM:

- IE0 = below state of the art.
- IE1 = state of the art.
- IE2 = above state of the art.

Danfoss VLT® drives fulfill energy efficiency class IE2. The energy efficiency class is defined at the nominal point of the CDM.

Power Drive System (PDS)

A *Power Drive System* consists of a Complete Drive Module and a motor.

Energy efficiency classes for the PDS:

- IES0 = Below state of the art.
- IES1 = State of the art.
- IES2 = Above state of the art.

Depending on the motor efficiency, motors driven by a Danfoss VLT® drive typically fulfill energy efficiency class IES2.

The energy efficiency class is defined at the nominal point of the PDS and can be calculated based on the CDM and the motor losses.

9.1.3 Power Loss Data and Efficiency Data

The power loss and the efficiency of a drive depend on configuration and auxiliary equipment. To get a configuration specific power loss and efficiency data, use the Danfoss [MyDrive ecoSmart tool](#).

The power loss data is provided in % of rated apparent output power and are determined according to IEC 61800-9-2. When the power loss data are determined, the drive uses the factory settings except for the motor data which is required to run the motor.

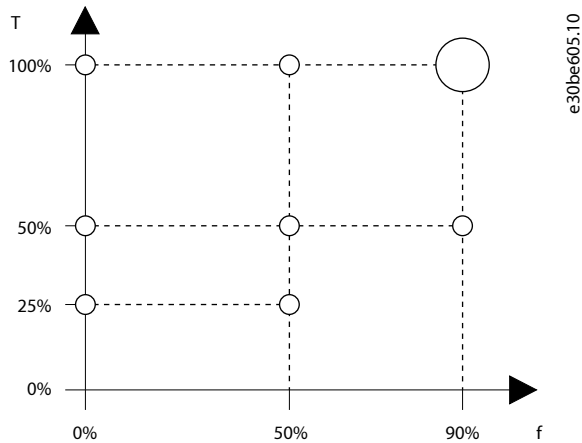

Figure 83: Drive Operating Points According to IEC 61800-9-2

T	Torque-producing current [%]	f	Frequency [%]
---	------------------------------	---	---------------

Use the Danfoss *MyDrive ecoSmart* application to calculate the power loss data and efficiency data of the drive at the operating points, and at the IE and IES efficiency classes. The application is available at [ecosmart \(danfoss.com\)](#).

Example of available data

The following example shows power loss and efficiency data for a drive with the following characteristics:

- Power rating 55 kW (75 hp), rated voltage at 400 V.
- Rated apparent power, S_r , 67.8 kVA.
- Rated output power, P_{CDM} , 59.2 kW (79.4 hp).
- Rated efficiency, η_r , 98.3%.

[Figure 84](#) and [Figure 85](#) show the power loss and efficiency curves. The speed is proportional to the frequency.

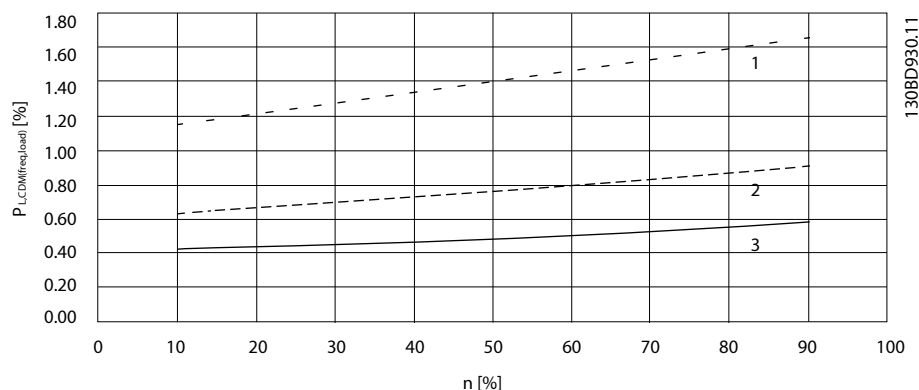

Figure 84: CDM Relative Losses (PL, CDM) [%] versus Speed (n) [% of Nominal Speed]

1	100% load	2	50% load
3	25% load		

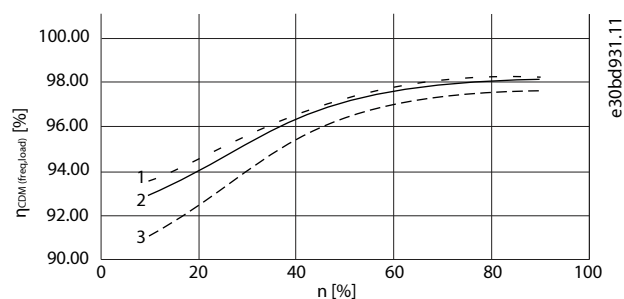

Figure 85: CDM Efficiency ($\eta_{CDM}(\text{freq}, \text{load})$) [%] versus Speed (n) [% of Nominal Speed]

1	100% load	2	50% load
3	25% load		

Interpolation of power loss

Determine the power loss at an arbitrary operating point using 2-dimensional interpolation.

9.1.4 Losses and Efficiency of a Motor

The efficiency of a motor running at 50–100% of the nominal motor speed and at 75–100% of the nominal torque is practically constant. This is valid both when the drive controls the motor, or when the motor runs directly on mains.

The efficiency depends on the type of motor and the level of magnetization.

For more information about motor types, refer to the brochure *Motor Technology - Free Choice* at danfoss.com.

9.1.5 Losses and Efficiency of a Power Drive System

To estimate the power losses at different operating points for a power drive system, sum the power losses at the operating point for each system component:

- Drive.
- Motor.
- Auxiliary equipment.

9.1.6 Losses and Efficiency

9.1.6.1 Losses and Efficiency of a Power Drive System with Installed Filter

The *MyDrive ecoSmart* calculation tool can be used for system calculations and creating an energy efficiency report. The tool can be found via danfoss.com.

The power loss of the VLT® Advanced Harmonic Filter is specified in 5 different operating points as 0–100% load. The current load and power loss are specified in each operating point. See [Table 37](#) for power losses.

The power loss in the AHF depends on the operating point and is a function of the input current in the AHF. The identification point of operation of the AHF is based on the input current to the drive. The input current of the drive equals the input current to the AHF.

$$I_{in,AHF} \neq I_{in,VLT}$$

The output current of the drive consists of the torque-producing component and the motor magnetization component. Different factors affect the relationship between the input current and output current of a drive. For example, part load causes a significant difference between the 2 currents. $I_{in,VLT} \neq I_{out,VLT}$

Calculate the input current of the drive with this formula:

$$I_{in,VLT} = I_{out,VLT} \times \cos(\phi) \times f_{motor}[\%] \times load_{motor}[\%] \times 1.02$$

- $I_{out,VLT}$: nominal output current from the drive. Find the data in the drive-specific design guide or in the *MyDrive ecoSmart*.
- $\cos(\phi)$: motor power factor. Find the data on the motor nameplate. Alternatively, use a reference value from IEC 61800-9-2, see [Table 88](#).
- f_{motor} : Percentage value of the nominal operating frequency in the motor in the range 0– 1.
- $load_{motor}[\%]$: percentage value of the torque-producing component or torque-producing current in the motor in the range 0–1. The value is typically from the design of the application.

The IEC 61800-9-2 standard for Ecodesign of Power Drive Systems allows the use of reference values. Determine the motor cosine phi value by the motor nominal power rating as kVA and with linear interpolation from the reference values in [Table 88](#).

Table 88: Motor Reference Values from IEC 61800-9-2

Nominal power [kVA]	Current [%]	Cosine phi
0.278	100	0.73
1.29	100	0.79
7.94	100	0.85
56.9	100	0.86
245	100	0.87

9.1.6.2 Calculation Example

The drive used in the example is a VLT® AutomationDrive FC 302, T5, 22 kW with Class A1/B RFI filter and enclosure protection rating IP20.

Drive values

- $I_{out,VLT}=44$ A.
- $\cos \phi=0.85$.
- $f_{motor} [\%]=25$ Hz, resulting in 50%.
- $load_{motor} [\%]=33$ A, resulting in 75% (33 A/44 A x 100).

In the example, VLT® Advanced Harmonic Filter AHF 010 with order number 130B1111 is selected as filter. See Code Numbers shown in [Table 7](#) for further specifications of the filter.

AHF values

- 40 A nominal current.
- AHF 010, THDi=10%.
- IP20.

Calculating the drive input current

$$I_{In, VLT} = I_{out, VLT} \times \cos(\phi) \times f_{motor} [\%] \times load_{motor} [\%] \times 1.02$$

$$I_{In, VLT} = 44 \times 0.85 \times 0.50 \times 0.75 \times 1.02 = 14.3A$$

Calculating the AHF input current

$$I_{In, AHF} = I_{In, VLT} = 14.3A$$

Calculating the power loss

Matching values from the tables in [7.3 Power Loss and Acoustic Noise Level](#).

- 86 W power loss at 10 A current loading.
- 142 W power loss at 20 A current loading.

Determining the power loss, $Loss_{OPT}$, in AHF point of operation $load_{OPT}$ using 2-dimensional interpolation.

- $Loss_2=142$ W.
- $Loss_1=86$ W.
- $Load_2=20$ A.
- $Load_1=10$ A.
- $Load_{OPT}=Load_{AHF}=Load$ of AHF in point of operation=14.3 A.
- $Loss_{OPT}=Loss_{AHF}=Loss$ in AHF in point of operation.

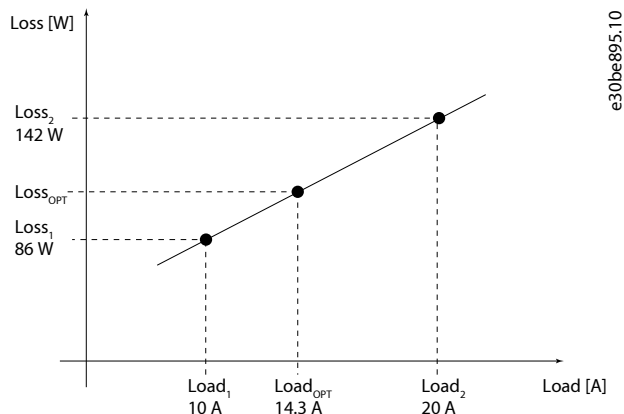

Figure 86: Determining Power Loss with 2-dimensional Interpolation

$$\text{Loss}_{\text{OPT}} = \text{Loss}_1 + (\text{Loss}_2 - \text{Loss}_1) \times ((\text{Load}_{\text{OPT}} - \text{Load}_1) \div (\text{Load}_2 - \text{Load}_1))$$

$$\text{Loss}_{\text{OPT}} = \text{Loss}_{\text{AHF}} = 86 + (142 - 86) \times ((14.3 - 10) \div (20 - 10)) = 110\text{W}$$

For system calculations and energy efficiency report, use the *MyDrive ecoSmart* tool.

The power loss of the drive provided by *MyDrive ecoSmart*

- Power loss @ 50% motor frequency and 50% motor current = 249 W.
- Power loss @ 50% motor frequency and 100% motor current = 490 W.

The power loss of the drive at 50% motor frequency and 75% torque-producing current are found by 2-dimensional interpolation as 370 W. $\text{Loss}_{\text{VLT}} = 370\text{ W}$.

Alternatively, identify the power loss of the drive by entering the point of operation in *MyDrive ecoSmart* as a user-defined operating point.

To determine the power loss of the CDM, sum up the power losses in the operating point of the AHF and the drive:

$$\text{Loss}_{\text{CDM}} = \text{Loss}_{\text{AHF}} + \text{Loss}_{\text{VLT}} = 110\text{W} + 370\text{W} = 480\text{W}$$



Danfoss A/S
Ulsnaes 1
DK-6300 Graasten
drives.danfoss.com

Any information, including, but not limited to information on selection of product, its application or use, product design, weight, dimensions, capacity or any other technical data in product manuals, catalog descriptions, advertisements, etc. and whether made available in writing, orally, electronically, online or via download, shall be considered informative, and is only binding if and to the extent, explicit reference is made in a quotation or order confirmation. Danfoss cannot accept any responsibility for possible errors in catalogs, brochures, videos and other material. Danfoss reserves the right to alter its products without notice. This also applies to products ordered but not delivered provided that such alterations can be made without changes to form, fit or function of the product. All trademarks in this material are property of Danfoss A/S or Danfoss group companies. Danfoss and the Danfoss logo are trademarks of Danfoss A/S. All rights reserved.

M00108
AJ315930123484en-000601
Danfoss A/S © 2025.12

