



100kW Power Conditioning System (PCS) Operation Manual



Version: 1.0.0

TABLE OF CONTENTS

About this Manual	1
Version Control.	1
IMPORTANT SAFETY INSTRUCTIONS	2
SAVE THESE INSTRUCTIONS.	2
System Power On/Off	3
Powering on PCS.	3
Powering off PCS.	4
Operations.	6
Front Panel.	6
Introduction of Front Panel.	6
Front Panel Flowchart	7
View PCS Operation Status	7
View the PCS Configuration Data	10
View the PCS Operation Data	11
View PCS Fault Information	12
View PCS Software Version & Adjust LCD Contrast	12
Check the Battery System Status and Data.	13
PCS HMI Tool	15
Introduction.	15
Installation	15
Making RS485 Connections.	17
PCS HMI Tool Instruction.	19
Configurable Parameters	26
System Parameters Configuration	26
Grid Code Parameters Configuration	31

Appendix	38
Event Log Fault Definition	38
Human Machine Interface Display	43

Conventions

General Conventions

The following conventions are used in this manual:



Note:

Indicates additional information that is relevant to the current process or procedure.

Copyright

The ownership and all intellectual property rights of this Operation Manual (this “Manual”), including but not limited to the content, data and figures contained herein are vested by Delta Electronics, Inc. (“Delta”). The Manual can only be applied to operation or use of the product. Any disposition, duplication, dissemination, reproduction, modification, translation, extraction or any other usage to the Manual is prohibited without obtaining Delta’s prior written permission. As the product will be developed and improved continuously, Delta may modify or update the Manual from time to time without any notice. Delta will do its best efforts to keep the Manual updated and maintain the accuracy of the Manual. Delta disclaims any kinds or forms of warranty, guarantee or undertaking, either expressly or implicitly, including but not limited to the completeness, accuracy, non-infringement, merchantability or fitness for particular purpose or usage.

Copyright © 2019 Delta Electronics, Inc. All Rights Reserved.

About this Manual

Version Control

Table 1: Version Control

Rev.	Change Description	Date

IMPORTANT SAFETY INSTRUCTIONS

SAVE THESE INSTRUCTIONS

General Safety Instructions

This manual contains important instructions for PCS that should be followed during installation and maintenance of the inverter.

PCS inverters are designed and tested to meet all applicable International safety standards. However, like all electrical and electronic equipment, safety precautions must be observed and followed during installation and operation of PCS inverters to reduce the risk of personal injury and to ensure a safe installation.

Installation, commissioning, service, and maintenance of PCS inverters must only be performed by qualified personnel that are licensed and/or satisfy state and local jurisdiction regulations.

Before starting installation or commissioning of the PCS, read through the entire manual and note all DANGER! WARNING! CAUTION!, and NOTICE! Statements.

All electrical installations must comply and be in accordance with all the state, local and utility regulations.

System Power On/Off

Powering on PCS

To power on the system, see the following guidelines:

1. After the PCS installation is completed, check to ensure that the upstream breaker is in the closed state before powering-on.
2. Turn the AC and DC switches on the front door to **ON** state as shown in Figure 1. The PCS powers on and enters standby mode.
3. Open PCS HMI Tool installed on the computer or PC, push the **PCS ON** button, then PCS will enter into **RUN** state.



Note:

- The setting and description of PCS HMI Tool, please refer to PCS100 communication protocol.
- For how to use PCS HMI Tool, please refer to “PCS HMI Tool” on page 15.
- According to the user request, use PCS HMI Tool to do the setup on site or use other controller to setup PCS100 according to the communication protocol at customer side.

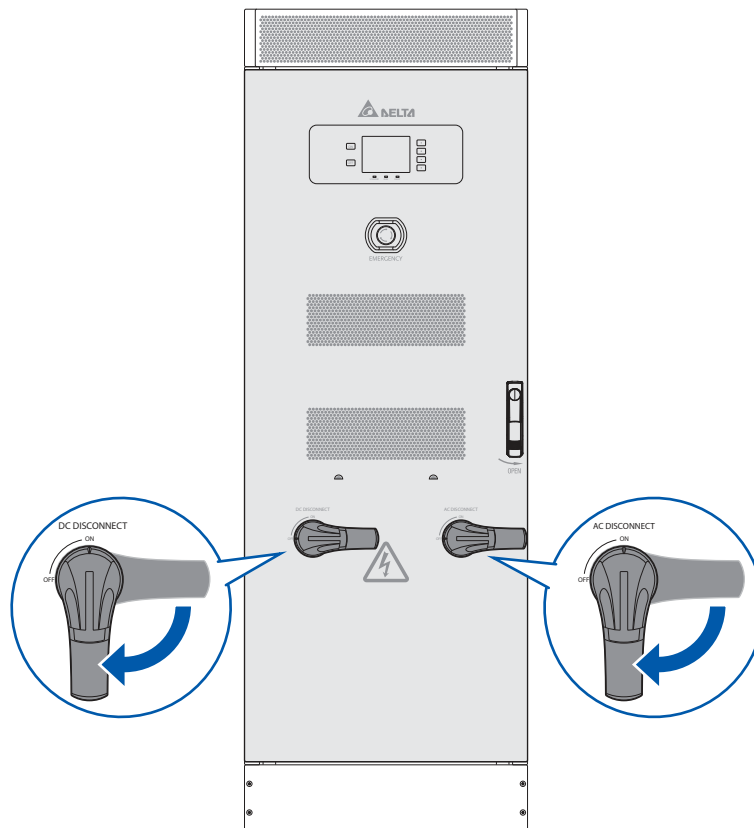

Figure 1. Turn AC and DC Switches to ON State

Powering off PCS

To power off the system, see the following guidelines:

1. Check the system status on the front display panel to ensure that the system is not in a **Soft-Start** or **Run** state.
2. If the system is in **Soft-Start** or **Run** state, push the **PCS OFF** button on PCS HMI Tool to switch the PCS system to Standby mode.



Note:

The **ON/OFF** button on PCS LCD panel doesn't work. Turning PCS on and off could only be available through the software such as PCS HMI Tool.



Figure 2. The Front Panel of PCS

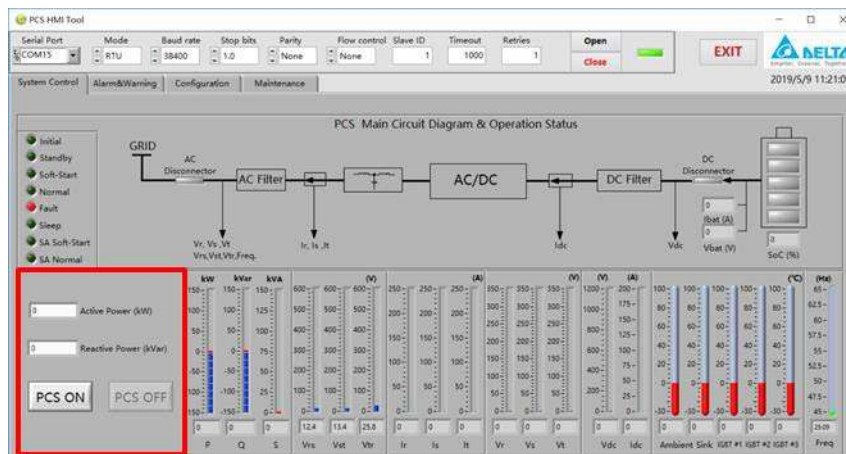

Figure 3. PCS HMI Tool - PCS ON/OFF Control

3. Turn the AC and DC switches on the front door to **OFF** state as shown in Figure 4.

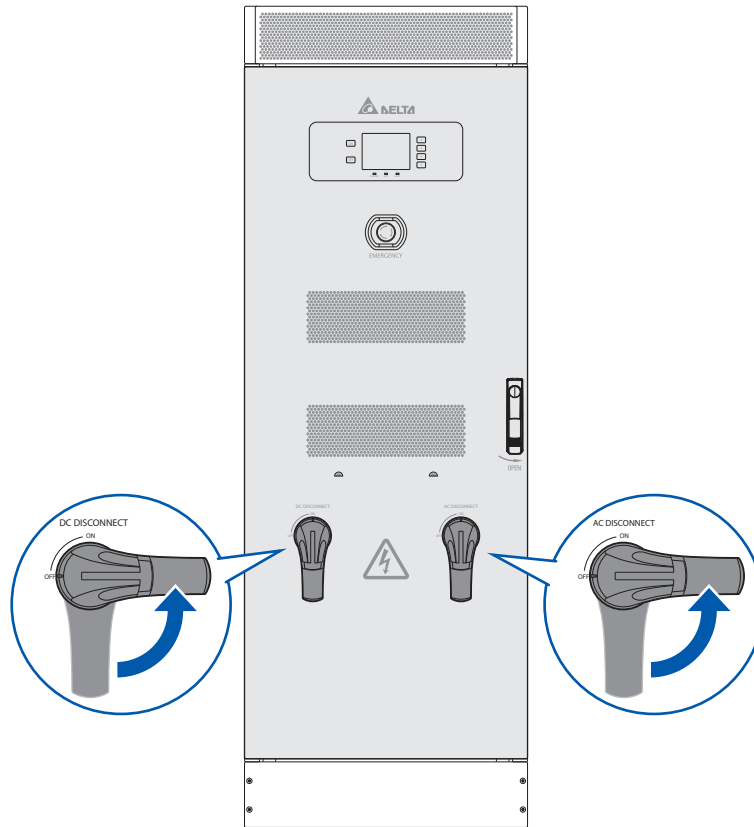

Figure 4. Turn AC and DC Switches to OFF State

Operations

Front Panel

Through the front panel the user can perform various PCS operations.

Introduction of Front Panel

The layout of the front panel is shown in Figure 5. It is divided into three areas: buttons, the LCD screen, and LED indicators.

- The LCD screen is located in the center of the front panel.
- The buttons are located on the left and right sides of the screen. The **ON/OFF** button on the left of PCS HMI doesn't work, and the four function buttons are distributed on the right side of the screen. Each function button can perform the relevant function described in the text box at the right side of the screen. For example, the first function button corresponding to ratings can show the PCS ratings, as shown in Figure 5.
- The LED indicators are located below the screen. From left to right, they are STANDBY (yellow), RUN (green), and FAULT (red), corresponding to the system operation status for standby, running, and fault. All three LEDs will be lighted if the user has not set the operation mode of the PCS.



Figure 5. PCS Functional Keypad on Control Panel

Front Panel Flowchart

The figure below shows the function structure and information displayed of the front panel:

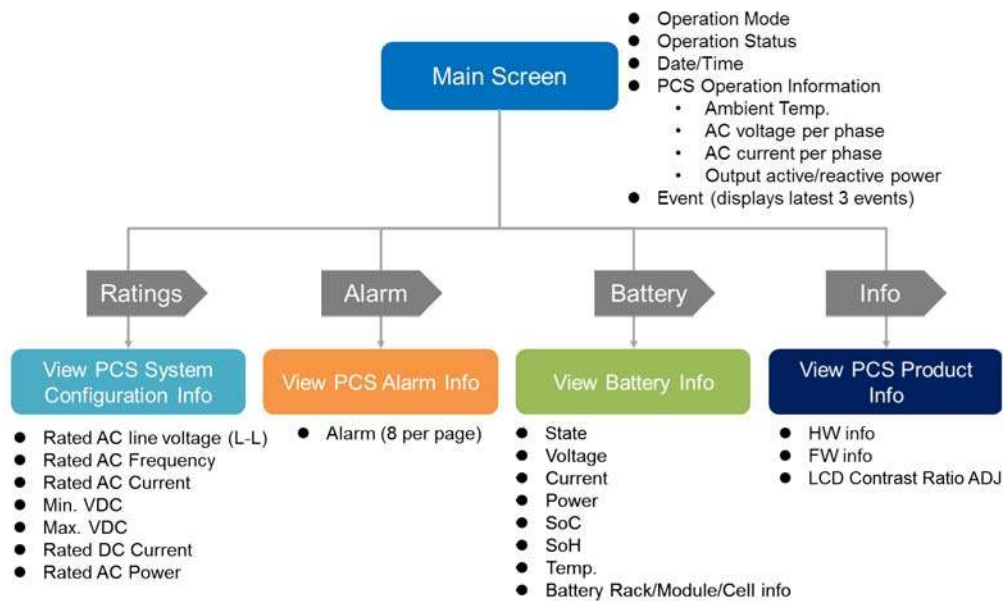

Figure 6. Front Panel Flowchart

View PCS Operation Status

The user can check the operation status of the PCS through the LEDs and the screen display. Please refer to Table 2 for the definitions of the LEDs below the screen.

Table 2: Definitions of LEDs on Control Panel

LED	Status
STANDBY (orange)	Standby
RUN (green)	Blinking: System soft-starting
	On: System running
FAULT (red)	System fault
All three LEDs are lighted	The system operation mode is not set

The current operation mode and status of the system can be seen in the top left corner of the screen home page, as shown in Figure 7 and Figure 8.

The block displays the system operation mode in the first line and the system operation status in the second line.



Figure 7. Operation Mode of PCS (1/2)



Figure 8. Operation Mode of PCS (2/2)

The specific operation mode definitions are shown in Table 3.

Table 3: Definitions of System Operation Modes

Operation Mode	Definition
NULL	A NULL display indicates no specific operation mode is configured.
Demand	A Demand display indicates the PCS is configured for Demand mode. In this mode, the PCS accepts the external P or Q commands and charges/ discharges the battery according to the grid requirements.
HMI Com Loss	An HMI Com Loss display indicates a loss of connection between the PCS internal controller and the HMI. The currently displayed information is not valid.

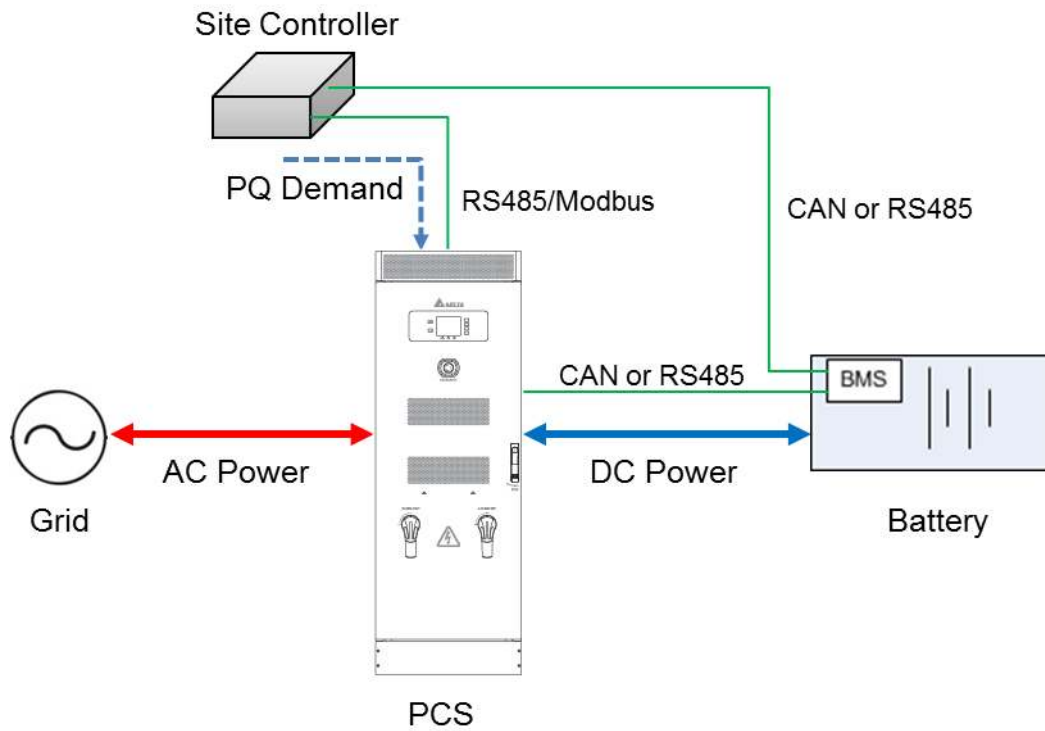

Figure 9. Illustration for Demand Mode

Refer to Table 4 for operation status definitions.

Table 4: Definitions of System Operation Statuses

Operation Status	Definition	Remark
Init	System is under initializing process	
Standby	System is in standby mode	
Soft Start	System is under soft-starting process	
Run	System is in normal operation	
Fault	System encountered any fault event	

View the PCS Configuration Data

Press the keypad on the right side of the panel, as shown in Figure 10, to enter the system configuration information page. PCS information is displayed in Figure 11. The user can return to the main page by pressing the corresponding **HOME** function in the current menu.



Figure 10. Enter Ratings Page through Function Keypad



Figure 11. Ratings Page

View the PCS Operation Data

The main data of the system will be presented through the main page of the screen display, including the system's operation mode, operation status, electrical metering, and event recording. Refer to Figure 12 and Table 5 for detailed descriptions.



Figure 12. Main Page

Table 5: Descriptions of PCS Operation Data

Block	Functional Description	Remark
1	Line 1: Operation mode Line 2: Operation status	When the communication between control panel and master controller is lost, HMI Com Loss is displayed on line 1 and line 2 is blank.
2	Display of the ambient temperature, three-phase voltage and current measurement data, the system output active power, and reactive power	
3	Event record	The system records the latest three events in chronological order.
4	Line 1: Date Line 2: Time	
5	Menu selection (associated with the functional buttons on the right side)	Blank means no next level menu to be displayed.

View PCS Fault Information

Press the function button corresponding to the Alarm function on the main page of the screen display to enter the alarm information pages. These pages display the current system alarm information, with each page showing up to 8 alarms. If the current number of faults exceeds 8 alarms, you can use the **NEXT** function to go to the next page for more information. In these fault pages, the user can press the **BACK** function button to return to the previous page or the **HOME** function button to the main page.



Figure 13. Alarm Page

View PCS Software Version & Adjust LCD Contrast

Press the Info function button on the main page of the screen display to enter the alarm information page. The page presents the current system software version information and can be returned from to the main page via the **HOME** function button.



Figure 14. Software Version Information Page

Under the interface of Info, press the **NEXT** button to enter the interface of LCD CONTRAST RATIO ADJ. According to user condition, adjust the ADJ value (Range 0 to 100) through **UP** and **DOWN** buttons.



Figure 15. Software Version Information Page

Check the Battery System Status and Data

The **Battery** function button on the main page allows the user to access information about the associated battery management system, as shown in Figure 16. The battery information is presented in multiple pages that can be accessed via the **NEXT** and **BACK** function buttons.

The user can return to the main page directly via the **HOME** function button as well.



Figure 16. Battery Information Page (1/4)



Figure 17. Battery Information Page (2/4)



Figure 18. Battery Information Page (3/4)



Figure 19. Battery Information Page (4/4)

PCS HMI Tool

Introduction

PCS HMI Tool could simulate and test the Modbus communication protocol, could use on monitoring, testing and adjusting Modbus communication equipment, also Modbus RTU protocol. PCS HMI Tool will install on PC and control PCS remotely.

PCS HMI Tool Installation Environment

- Operating System: from Windows 7 SP1 to Windows 10
- Hardware: 2 GB memory/800 MHz CPU/ USB or serial port

Installation

1. Open software setup package, double click **setup.exe** to start installation.

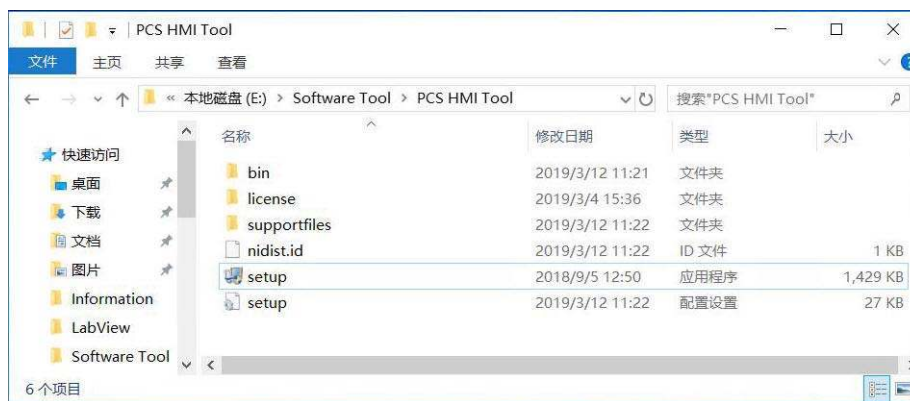

Figure 20. Software Setup Package

2. Installation interface as shown, you can also modify the default installation file path, then click **Next**.

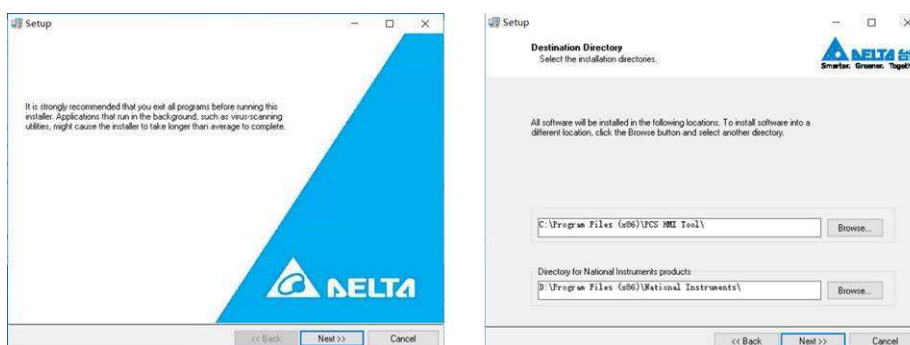

Figure 21. Installation (1/5)

3. Select "I accept the above 2 License Agreement(s)" and click **Next**.

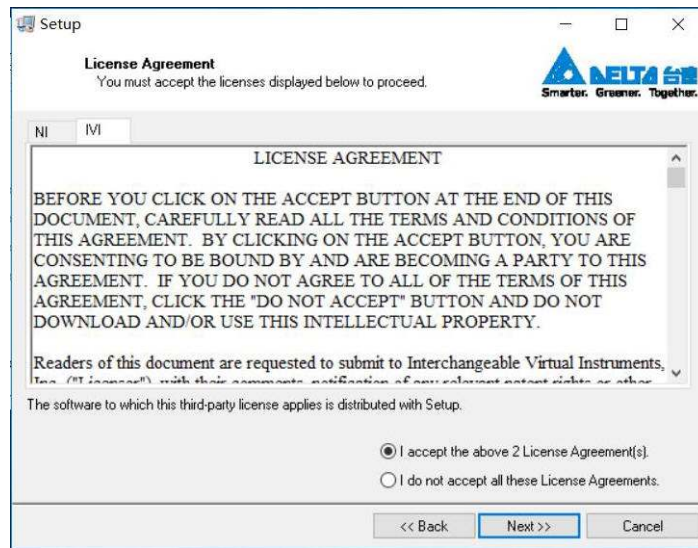

Figure 22. Installation (2/5)

4. Click **Next**.

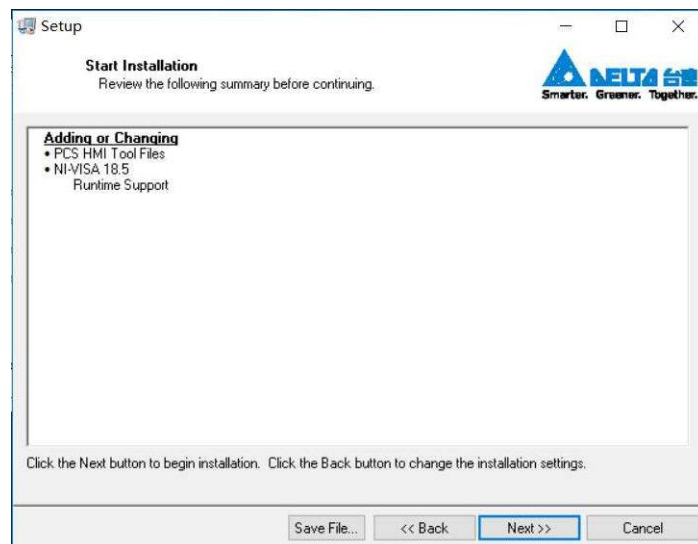

Figure 23. Installation (3/5)

5. After installation complete, click **Finish** and **Restart** computer.

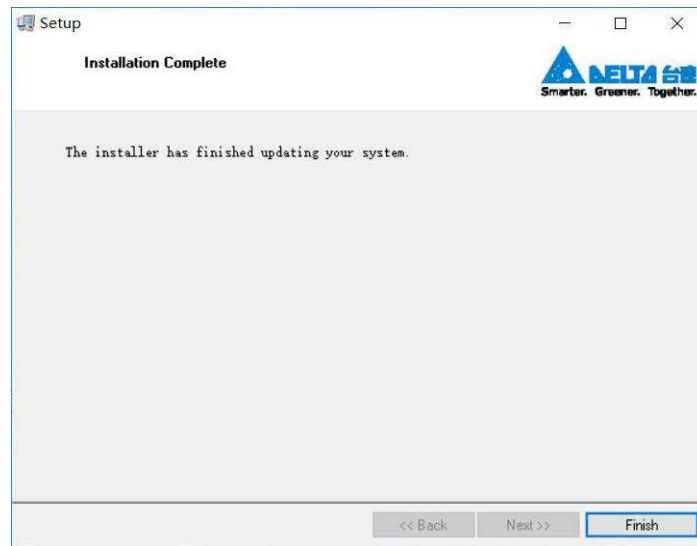

Figure 24. Installation (4/5)

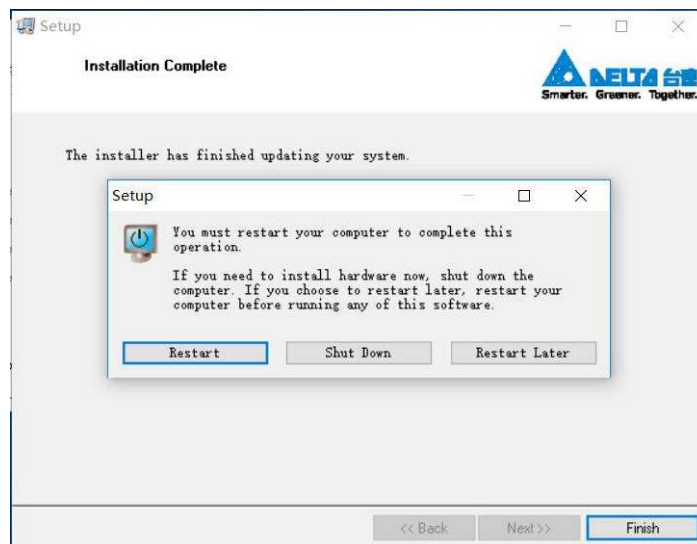

Figure 25. Installation (5/5)

Making RS485 Connections

The RS485 communication link on the PCS100 uses a two-wire electrical interface in accordance with the EIA/TIA-485 standard. There are actually three wires in use, the third wire is considered a common connection. A shielded cable must be used for all links between devices with the shield of each segment being connected to ground at one end only.

Note on RS485 Pinout Markings

The polarity of the data lines must be verified. On some devices, the Data (+) may be labeled Data A and Data (-) may be labeled Data B. However, not all manufacturers follow this convention for A and B. It is recommended to use the (+) and (-) labels for polarity to ensure a connection. If a device does not respond, try reversing the lines to see if the device responds (no damage will occur).

Connecting Devices

Controlling master devices must be connected to the PCS system using a daisy-chain technique (Figure 26 and Figure 27).

See the following guideline for further information.

1. Find the CNJ11/CNJ12 or CNJ7 on the J board. For more details, see “Communication and I/O Wiring” in the Installation Manual.
2. Connect one end of the cable to the PCS100 and the other end of the cable to the PC or the controller, see the following figures.

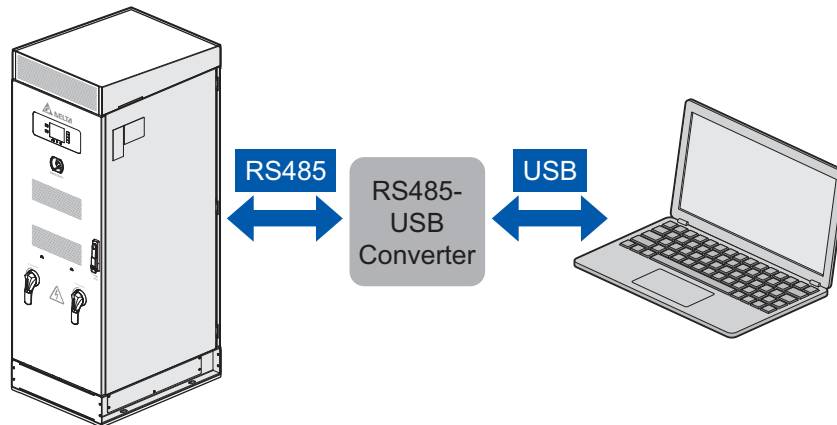

Figure 26. Connecting PCS and PC

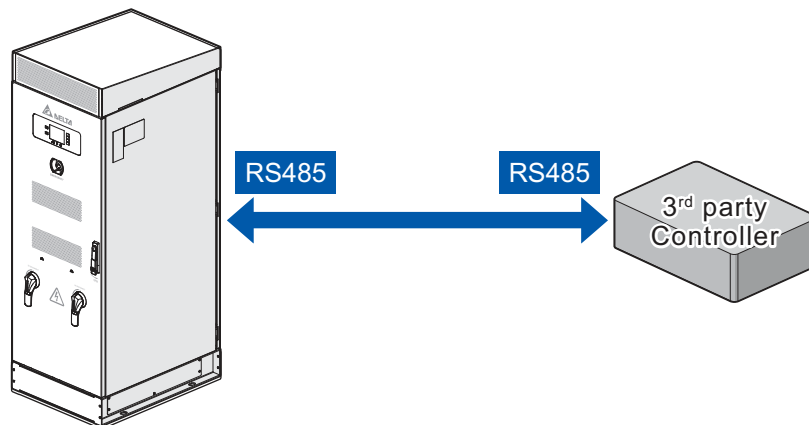

Figure 27. Connecting PCS and Controller

3. Use the PCS HMI Tool to control, configure and monitor the PCS.

PCS HMI Tool Instruction

1. Connect PCS HMI Tool.

Step 1: Plug the RS485-USB converter into available USB port on both PCS100 and PC, check the COM port number for communication. Open the device manager, and select the port (COM and LPT) for finding the corresponded USB serial port

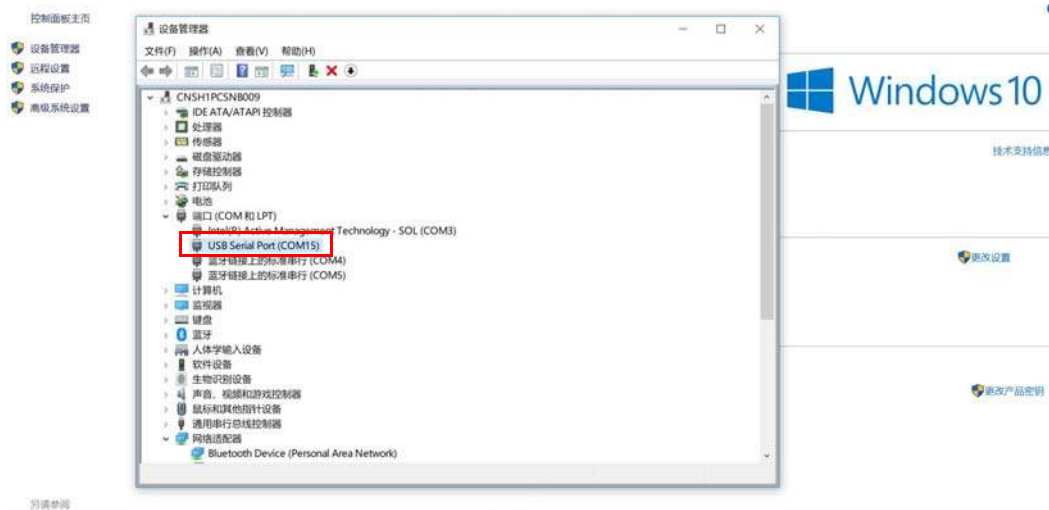

Figure 28. Selecting the Port

Step 2: Connect PCS HMI Tool.

Major settings are as below red frame (Figure 29).

- Select correspond serial port number from “Serial Port” drop down box.
- Enter the PCS ID number in the “Slave ID” input box.
- Generally, the others keep default value.

After completing the communication parameter configuration, click the **Open** button. If the connection is successful, the status indicator “■” will show green.

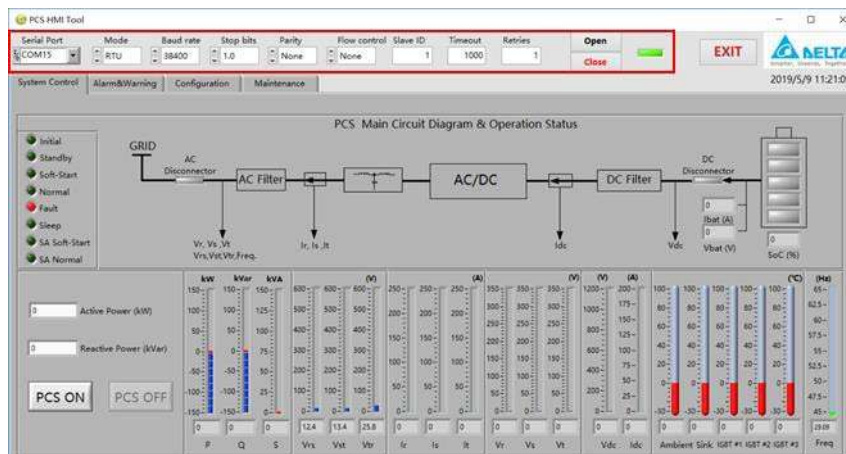

Figure 29. Connecting PCS HMI Tool

Step 3: Disconnect PCS HMI Tool. Click the **Close** button to disconnect communication. The status indicator “■” will show red.

Step 4: Exit PCS HMI Tool, click the “EXIT” button to close PCS HMI Tool application.

2. PCS ON/OFF Operation.

The PCS control area is shown in the red box below (Figure 30). including PCS ON/OFF command, Active power and Reactive power command input.

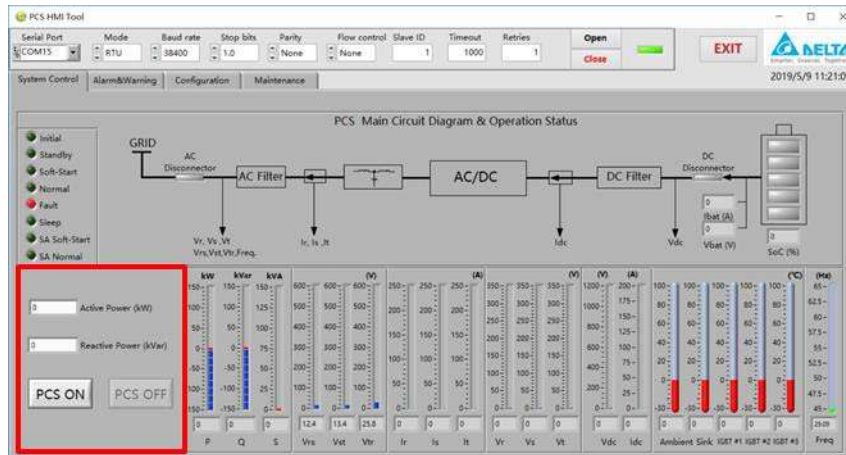

Figure 30. PCS Operation Command

- PCS ON: PCS run command.
- PCS OFF: PCS stop command.



Note:

Indicates additional information that is relevant to the current process or procedure.

- Active Power: Active power command input. Default: 0, unit: kW.
- Reactive Power: Reactive power command input. Default: 0, unit: kVar.

3. System status monitoring.

As Figure 31, it display the running status of the PCS device, including the following information.

Table 6: Running Status

Index	Description
1	<ul style="list-style-type: none"> ● Grid side voltage <ul style="list-style-type: none"> ● line-line voltage: Vrs, Vst, Vtr ● phase voltage: Vr, Vs, Vt ● Load current (Ir, Is, It) ● Grid side frequency (Freq.)
2	<ul style="list-style-type: none"> ● DC bus voltage (Vdc) ● DC bus current (Idc)
3	<ul style="list-style-type: none"> ● Battery voltage (Vbat) ● Battery current (Ibat) ● Battery SoC (SoC)
4	<ul style="list-style-type: none"> ● Active power (P) ● Reactive power (Q) ● Apparent power (S)

Table 6: Running Status (Continued)

Index	Description
5	<ul style="list-style-type: none"> Power module temperature (IGBT#1, 2, 3, 4) Sink temperature (Sink) Ambient temperature (Ambient)
6	PCS running status (Initial, Standby, Soft-start, Normal, Fault, Sleep, SA soft-start, SA Normal)
7	<ul style="list-style-type: none"> DC disconnect status (Close/Open) AC disconnect status (Close/Open)

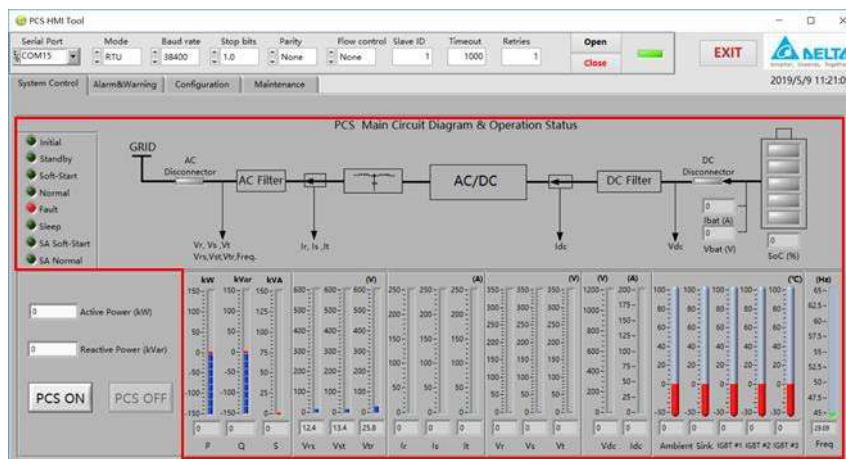

Figure 31. PCS Running Status Information

4. Alarm & Warning.

Monitor PCS system fault and alarm information, including PCS device, battery and power module fault information. Click the **CLEAR FAULT** button to clear all fault. Detailed fault information can be found in the appendix.

a. Device Alarm &Warning

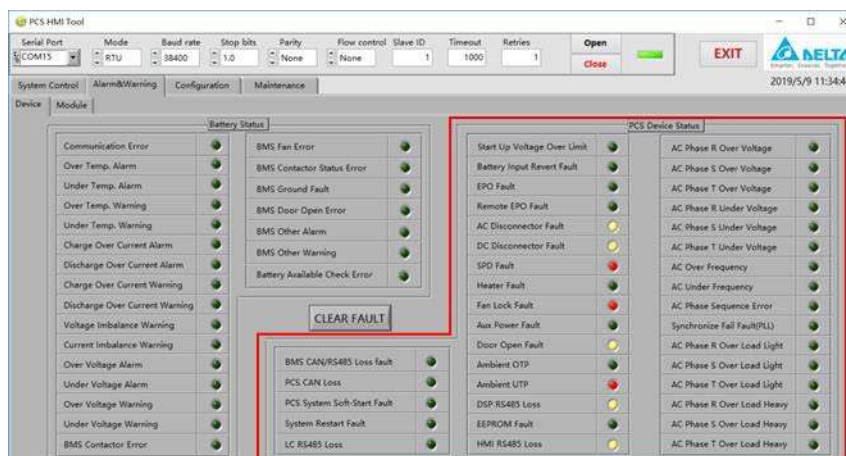

Figure 32. PCS Device Alarm & Warning

b. Battery Alarm & Warning

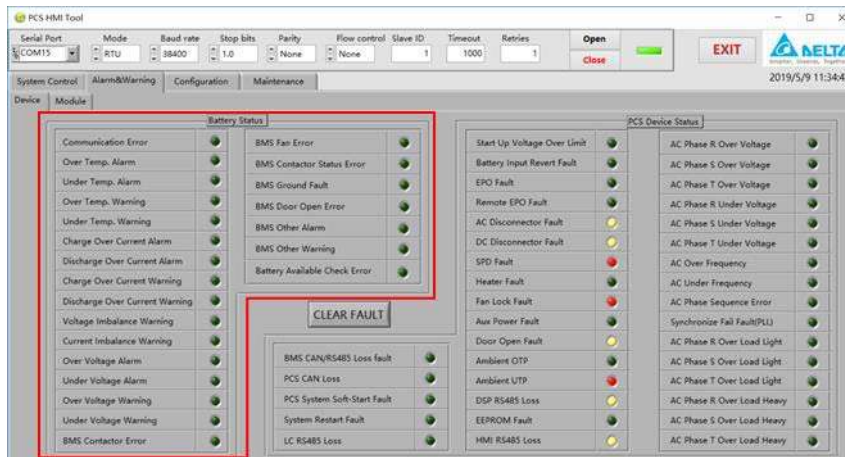

Figure 33. Battery Alarm & Warning

c. Power Module Alarm & Warning

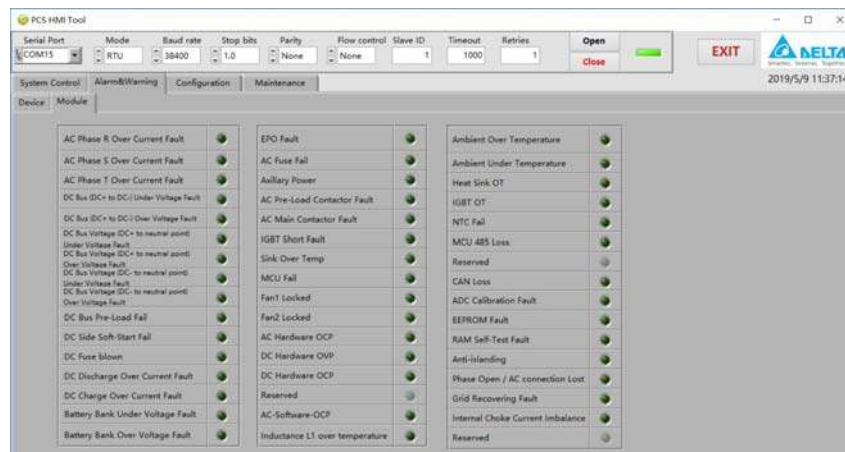

Figure 34. PCS Power Module Alarm & Warning

5. Parameters Configuration.

The PCS device parameter configuration consists of two parts:

- PCS system parameters
- Grid code parameters

The parameters can only be configured (read or write) while the PCS is in “OFF” state.

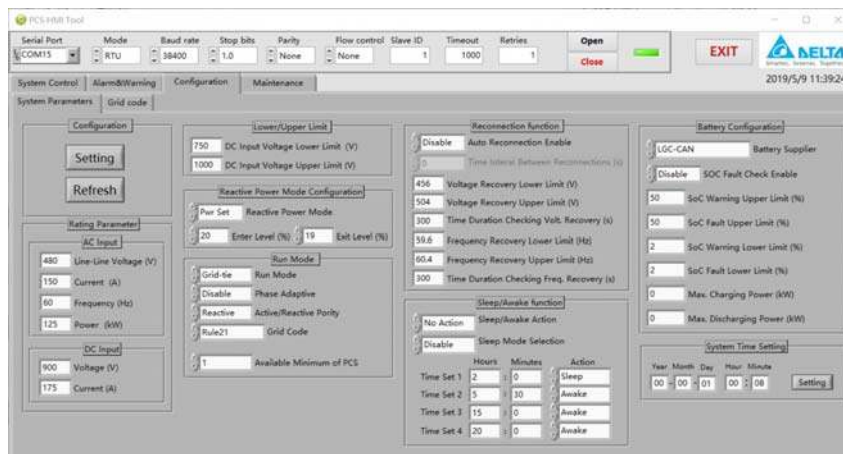

Figure 35. PCS System Parameters Configuration

The configuration steps are as follows:

Step 1: Confirm that the PCS is in the “OFF” state, which can be achieved by clicking the **PCS OFF** button on the **System control** page.

Step2: When the PCS is in the “OFF” state, the **Refresh** button in the **Configuration** page will be activated.

Step3: Click the **Refresh** button to read the current configuration parameter value. After modifying one or more parameters, click the **Setting** button to complete the parameter reconfiguration.

Step4: To ensure the parameter configuration is successful, wait for 2s, then click the **Refresh** button to confirm again.

a. System Parameters

It mainly includes the PCS device rated operating parameters, running mode settings, threshold settings, etc., as shown in the Figure 35.

b. Grid code parameters

The PCS device adjusts the necessary operating parameters, running mode settings, threshold settings, etc. according to the difference of the application area and following the local power grid regulations, as Figure 36.

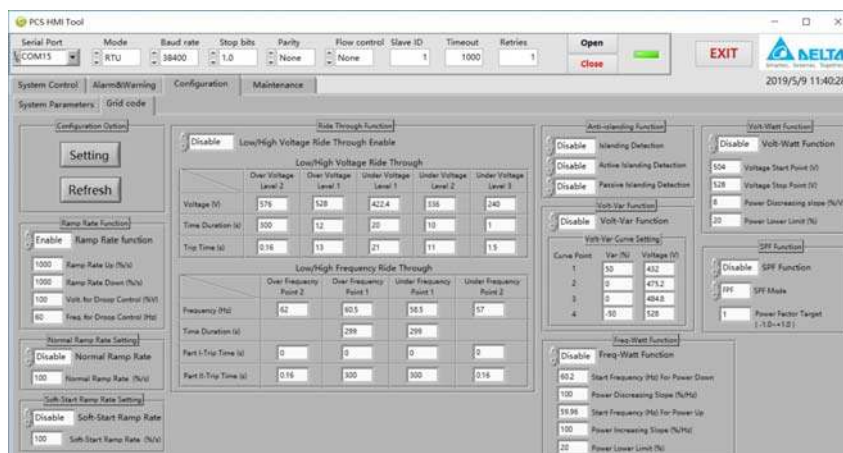

Figure 36. Grid Code Parameters Configuration

6. Maintenance

As Figure 37, it mainly reads the PCS serial number, the firmware version number and the PCS fault log, and stores log information. The Fault log can only be read when the PCS is in the "OFF" state.

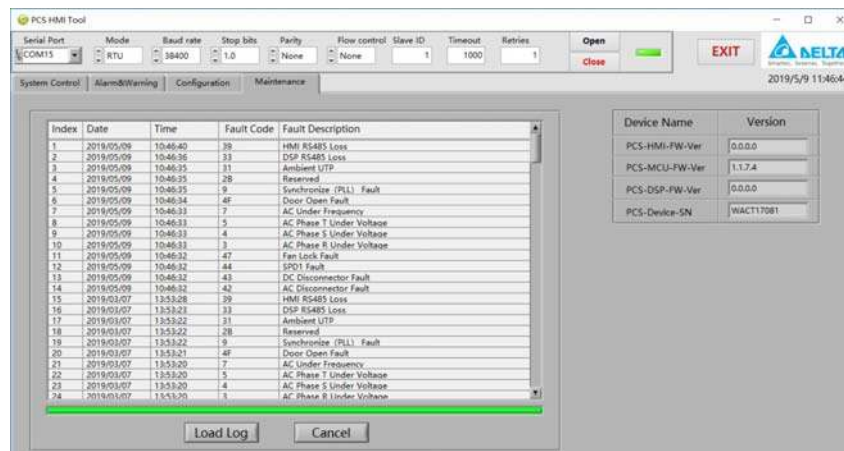

Figure 37. PCS Maintenance Information

Steps are as follows:

Step1: Confirm that the PCS is in the "OFF" state, the **Load Log** button is bright color, otherwise it is gray.

Step2: Click the **Load Log** button, a message dialog will pop up, please click **OK**, as Figure 38.

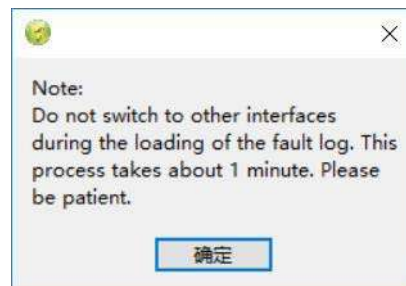

Figure 38. Reminder Dialog

Step 3: Wait patiently for the fault log information to be loaded. When finished, a message dialog will pop up, click **OK** to end the reading action, as Figure 39.

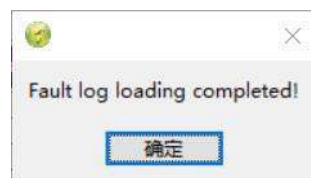

Figure 39. Load Completion Message Box



Note:

The reading of fault log information can be canceled by clicking **Cancel** button.

Save the data as follows:

Step 1: In any area of the table, right-click and the following dialog box will pop up, as Figure 40.

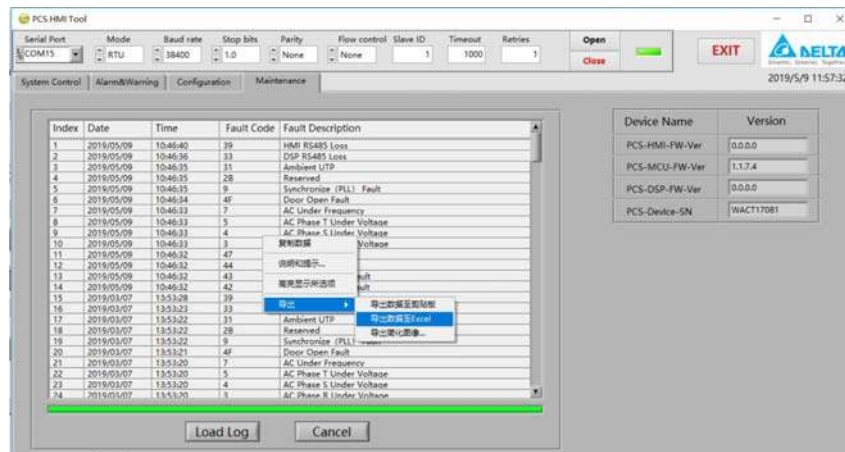
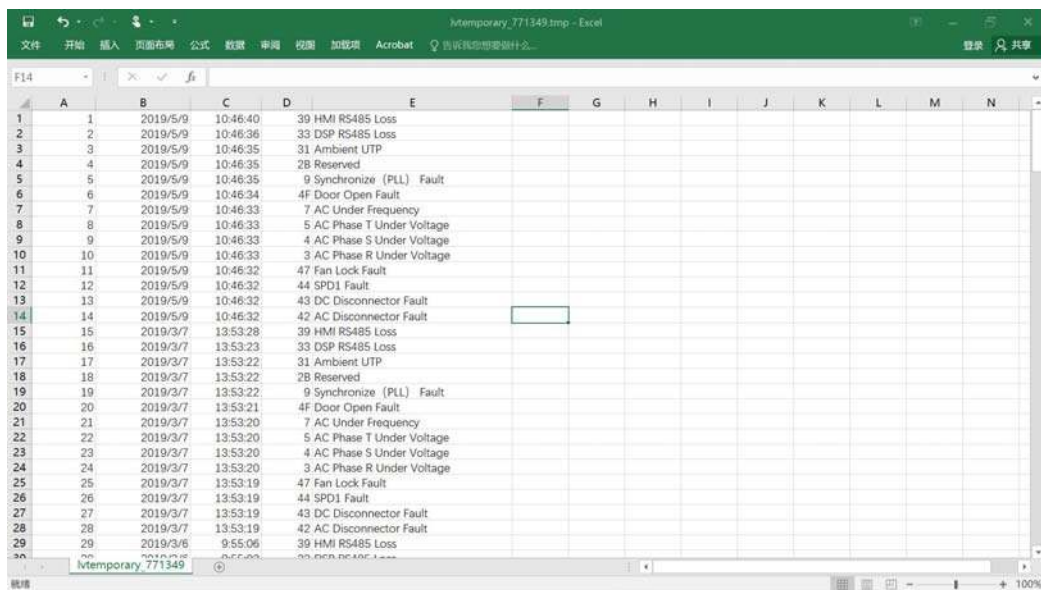

Figure 40. Save Fault Log Information

Step 2: Select **Export data to Excel** from the **Export** option and click the left mouse button. The Microsoft Excel application will open automatically and the data will be stored in the temporary file, as Figure 41.



Configurable Parameters

The PCS device is VDE-AR-N4105 and AS/NZS 4777.2 certified. There are several parameters configurable for the VDE-AR-N4105 and AS/NZS 4777.2 functions as shown in the following tables, and users can configure these parameters through communication with the PCS HMI Tool. Grid code AS4777.2 and default value of related parameters are set as factory default.

System Parameters Configuration

The part mainly describes configurable system parameters of PCS device.

Running Mode

Table 7: PCS Run Mode Parameters Configuration

Definition	Description	Unit	Min	Max	Default
Run Mode					
Run Mode	0: PCS Run with Grid-tie mode 1: PCS Run with Grid off/ Standalone mode	NA	0	1	0
Phase Adaptive	Auto adaptive grid phase sequence. 0: Disable 1: Enable	NA	0	1	0
Active/Reactive Priority	Setting priority of active power / reactive power. 0: Reactive first 1: Active first	NA	0	1	0
Grid Code	Grid code type setting: 0-4: Reserved 5: VDE4105 6 JAP(TBD) 7: AS4777.2 8: NZS4777.2	NA	5	8	7
Available Minimum of PCS	Setting the minimum of PCSs available in master-slave parallel system	NA	1	8	1
Reactive Power Mode Configuration					
Reactive Power Mode	Reactive Power Mode Selection. 0: SPF (Specified Power Factor) 1: Power Set (Demand response) 2: PFP ($\cos \phi$ (P) curve) 3: Volt-Var Other: NA	NA	0	4	1

Power Demand

Table 8: PCS Power Demand Configuration

Definition	Description	Unit	Min	Max	Default
Active Power	Setting active power demand of the system. Positive means PCS sources active power to the grid. Negative power means PCS sinks active power from the grid. The definition of active power in this document is the same unless otherwise specified.	kW	-100	100	0
Reactive Power	Setting reactive power demand of the system. Positive means PCS sources reactive power to the grid. Negative means PCS sinks reactive power from the grid.	kVar	-100	100	0
DRM Reactive Power	Reactive power demand of DRM3 and DRM7. (AS/ NZS4777.2 Only) The direction of reactive power is defined the same as the parameter above.	kVar	-60	60	0



Note:

Before the function is enabled, the “Reactive Power Mode” must be set to “Power Set”.

Reconnection Function

Table 9: PCS Reconnection Parameters Configuration

Definition	Description	Unit	Min	Max	AS	VDE	NZS
Auto Reconnection Enable	Auto Restart/Reconnect function enable. 0: Disable 1: Enable	NA	0	1	1	1	1
Voltage Recovery Lower Limit	Lower limit of voltage recovery.	V	280	400	355.1	340	342.9
Voltage Recovery Upper Limit	Upper limit of voltage recovery.	V	400	460	438.2	440	438.2

Table 9: PCS Reconnection Parameters Configuration (Continued)

Definition	Description	Unit	Min	Max	AS	VDE	NZS
Time Duration Checking Volt. Recover	Time duration for checking if voltage is recovered in normal range.	s	30	300	60	60	60
Frequency Recovery Lower Limit	Lower limit of frequency recovered to normal operational range.	Hz	45	50	47.5	47.5	47.5
Frequency Recovery Upper Limit	Upper limit of frequency recovered to normal operational range.	Hz	50	55	50.15	50.05	50.15
Time Duration Checking Freq. Recovery	Time duration for checking if frequency is recovered in normal operational range.	s	30	300	60	60	60

Sleep & Awake Function

Table 10: PCS Sleep & Awake Parameters Configuration

Definition	Description	Unit	Min	Max	Default
Sleep/Awake Action	Command for asking system turn to sleep or awake mode: 1: Sleep; 2: Awake; Other: No action	NA	0	2	0
Sleep Mode Selection	Enable and enter Auto and/or Schedule sleep mode, or disable sleep mode. 0: Disable. 1: Enable Auto; 2: Enable Schedule; 3: Both Auto and Schedule are enabled. Note: Before Schedule mode is enabled, the following registers should be set in advance.	NA	0	3	0

Table 10: PCS Sleep & Awake Parameters Configuration (Continued)

Definition	Description	Unit	Min	Max	Default
Time Set 1	hours	NA	0	23	2
	minutes	NA	0	59	0
	Action: 0: No action 1: Sleep 2: Awake If this schedule is same as last time point, no action to system.	NA	0	2	1
Time Set 2	hours	NA	0	23	5
	minutes	NA	0	59	30
	Action: 0: No action 1: Sleep 2: Awake If this schedule is same as last time point, no action to system.	NA	0	2	2
Time Set 3	hours	NA	0	23	15
	minutes	NA	0	59	0
	Action: 0: No action 1: Sleep 2: Awake If this schedule is same as last time point, no action to system.	NA	0	2	2
Time Set 4	hours	NA	0	23	20
	minutes	NA	0	59	0
	Action: 0: No action 1: Sleep 2: Awake If this schedule is same as last time point, no action to system.	NA	0	2	2

Battery Configuration

Table 11: Battery Parameters Configuration

Definition	Description	Unit	Min	Max	Default
Battery Supplier	0: DELTA-ESD-CAN 1: LGC-CAN 2: SAMSUNG-SDI-RS485 3: DELTA-ESD-RS485 Other: Reserved	NA	0	8	1
Battery Fault Check Enable	Battery fault check switch: 0: Disable (Default) 1: Enable	NA	0	1	0
SoC Warning Upper Limit	Setting upper limit for battery pack SoC warning. When SoC is greater than this setting value, a "Battery SoC High Warning" is reported. If Battery SOC High Warning is reported. The system do not allow to charge the battery.	%	50	100	90
SoC Fault Upper Limit	Setting upper limit for battery pack SoC fault. When SoC is greater than this setting value, a "Battery SoC High Fault" is reported.	%	50	100	95
SoC Warning Lower Limit	Setting lower limit for battery pack SoC warning. When SoC is less than this setting value, a "Battery SoC Low Warning" is reported. If Battery SOC Low Warning is reported. The system do not allow to discharge the battery.	%	2	50	10
SoC Fault Lower Limit	Setting lower limit for battery pack SoC fault. When SoC is less than this setting value, a "Battery SoC Low Fault" is reported.	%	2	50	5

System Time Setting

Table 12: PCS Device System Time Setting

Definition	Description	Unit	Min	Max	Default
System Time	Year	NA	0	99	0
	Month	NA	0	12	0
	Day	NA	0	31	1
	Hour	NA	0	23	0
	Minute	NA	0	59	8

Grid Code Parameters Configuration

The PCS supports operating in compliance with several grid code rules, such as VDE-AR-N4105 and AS/NZS 4777.2. There are several parameters configurable for the grid code functions as shown in the following tables.

Anti-Islanding Protection Function

Table 13: Anti-islanding Protection Parameters Configuration

Definition	Description	Unit	Min	Max	Default
Islanding Detection	Setting if islanding detecting function is enabled or not. 0: Disable. 1: Enable.	NA	0	1	0

Voltage Protection Setting

Table 14: Voltage Protection Parameters Configuration

Definition	Description	Unit	Min	Max	AS	VDE	NZS
Over Voltage Level 2 (OVL2)	Over Voltage Trip Point Level 2 Settings: Configure this voltage value according to grid code.	V	400	480	459	460	459
Trip time for OVL2	Over Voltage Trip Time Level 2. Configure this time value according to grid code.	s	0.1	300	0.2	0.2	0.2
Over Voltage Level 1 (OVL1)	Over Voltage Trip Point Level 1. Configure this time value according to grid code.	V	400	480	450.3	440	450.3

Table 14: Voltage Protection Parameters Configuration (Continued)

Definition	Description	Unit	Min	Max	AS	VDE	NZS
Trip time for OVL1	Over Voltage Trip Time Level 1. Configure this time value according to grid code.	s	0.1	300	1.5	0.2	1.5
Under Voltage level 1(UVL1)	Under Voltage Trip Point Level 1. Configure this voltage value according to grid code.	V	280	400	311.7	320	311.7
Trip time for UVL1	Under Voltage Trip Time Level 1. Configure this time value according to grid code.	s	0.1	300	1.5	0.2	1.5

**Note:**

All the voltage protective limits of AS/NZS are secured against change.

Frequency Protection Setting

Table 15: Frequency Protection Parameters Configuration

Definition	Description	Unit	Min	Max	AS	VDE	NZS
Over Frequency Point 1(OF1)	Over Frequency Trip Point Level 1. Configure this frequency value according to grid code.	Hz	50	55	52	51.5	52
Trip Time for OF1	Over frequency level 1 trip time. Configure this time value according to grid code.	s	0.1	1000	0.2	0.2	0.2
Under Frequency Point 1(UF1)	Under Frequency Trip Point Level 1. Configure this frequency value according to grid code.	Hz	45	50	47	47.5	45
Trip Time for UF1	Under frequency level 1 trip time. Configure this time value according to grid code.	s	0.1	1000	1	0.2	1

**Note:**

All the frequency protective limits of AS/NZS are secured against change.

Ramp Rate Function

Table 16: Ramp Rate Parameters Configuration

Definition	Description	Unit	Min	Max	AS	VDE	NZS
Normal Ramp Rate Setting							
Normal Ramp Rate Enable	Setting Normal Ramp Rate function enable or disable: 0: Disable 1: Enable	NA	0	1	0	1	0
Normal Ramp Rate	Normal Ramp Rate. Unit %Prated/s.	%Prate/s	0	200	0.28	100	0.28
Soft-Start Ramp Rate Setting							
Soft-Start Ramp Rate Enable	Disable or Enable Soft Start ramp rate function 0: Disable 1: Enable	NA	0	1	1	1	1
Soft-Start Ramp Rate	Setting Soft Start ramp Rate. Unit %Prated/s.	%Prate/s	0	200	0.28	100	0.28

Volt-Var Function

Table 17: Volt-Var Parameters Configuration

Definition	Description	Unit	Min	Max	AS	VDE	NZS
Volt-Var Function Enable	Volt -Vars function setting: 0: Disable; 1: Enable; Note: (1) Before the function is enabled, the “Reactive Power Mode” must be set to “Volt-Var”. (2)It will be activated when input power is greater than the value “Enter Level”.	NA	0	1	0	0	0
Curve Point 1	Q1, Cap. High	%	0	100	30	50	30
	V1, Voltage min	V	320	400	358.5	360	358.5
Curve Point 2	Q2, Cap. Low	%	0	100	0	0	0
	V2, Voltage Low	V	320	400	381	380	381
Curve Point 3	Q3, Ind. Low	%	-100	0	0	0	0
	V3, Voltage Normal	V	400	480	433	420	422.6

Table 17: Volt-Var Parameters Configuration (Continued)

Definition	Description	Unit	Min	Max	AS	VDE	NZS
Curve Point 4	Q4, Ind. Max	%	-100	0	-30	-50	-30
	V4, Voltage High	V	400	480	459	440	441.7

Volt-Watt Function

Table 18: Volt-Watt Parameters Configuration

Definition	Description	Unit	Min	Max	AS	VDE	NZS
Volt-Watt Function Enable	Volt-Watt Function enable: 0: Disable 1: Enable	NA	0	1	1	0	1
Over Voltage Start Point	Setting V-Watt Function voltage start point.	V	400	480	433	420	422.6
Power Decreasing Slope for Over Voltage	Decreasing Power rate if Voltage above V_START.	%Prate/ 1%Vrate	0	100	12.27	8	12.27
Power Lower Limit	Setting output power lower limit for V-Watt function.	%	-100	100	20	20	20
Under Voltage Start Point	Volt-Watt function in voltage drop side. (AS/NZS 4777.2 only) When voltage of AC side is lower than this value, input power from the grid will be decreased.	V	320	400	380	NA	380
Power Decreasing Slope for Under Voltage	The decreasing power rate when voltage goes down. (AS/NZS 4777.2 and charge mode only)	%Prate/ 1%Vrate.	0	100	17.77	NA	17.77

Freq-Watt Function

When a grid frequency disturbance results in an increase in grid frequency, the PCS will reduce the output power level to the grid. When AS or NZS is selected, the PCS will reduce the input power level from the grid when a grid frequency decrease represents.

Table 19: Freq-watt Parameters Configuration

Definition	Description	Unit	Min	Max	AS	VDE	NZS
Freq-Watt Function Enable	Freq-Watt Function enable. 0: Freq-Watt function is disabled 1: Freq-Watt function is enabled	NA	0	1	1	0	1
Start Point for Over Frequency	Freq-Watt function start point.	Hz	50	55	50.25	50.2	50.25
Power decreasing Slope for Over Frequency	Decreasing power rate if frequency above start frequency.	%Prate/Hz	0	200	57	40	57
Power Lower Limit	Output power lower limit for Freq-Watt function.	%	-100	100	0	20	0
Start Point for Under Frequency	Freq-Watt function in frequency drop side. Output power to the grid increases when frequency is lower than this value. (for VDE4105) Input power from the grid decreases when frequency is lower than this value. (for AS/NZS4777.2 and charge mode)	Hz	45	50	49.75	49.8	49.75
Power Slope for Under Frequency	Increase rate of output power to the grid. (for VDE4105) Decrease rate of input power from the grid. (for AS/NZS4777.2 and charge mode)	%Prate/Hz	0	2000	133	0	133

Specified Power Factor Function (SPF)

Table 20: SPF Parameters Configuration

Definition	Description	Unit	Min	Max	AS	VDE	NZS
SPF Function Enable	Specified Power Factor function configuration. 0: Disable 1: Enable Note: (1) Before the function is enabled, the “Reactive Power Mode” must be set to “SPF”. (2) It will be activated when input power is greater than the value “Enter Level”.	NA	0	1	0	0	0
SPF Mode	Mode Priority Setting: 0: FPF (Fixed Power Factor) 1: PFAP (Power Factor Mode & Active Power Priority)	NA	0	1	0	0	0
Entry Power Level	Entry level for active power in Volt-Var, SPF, PFP mode. If the absolute value of active power is higher than this level, those functions (Volt-Vars, SPF, PFAP) would be activated.	%Prate	0	100	20	20	20
Exit Power Level	Exit level for active power in Volt-Vars, SPF, PFP mode. If the absolute value of active power is lower than this level, Those functions would be disabled. Note: This setting should be lower than the value “Entry level”.	%Prate	0	100	19	19	19
Power Factor Target	The target power factor for SPF mode. It will be activated when input power is greater than the value “Enter level”.	NA	-1.00	1.00	1.00	1.00	1.00

**Note:**

Leading power factor means PCS sources reactive power to the grid, and power factor is defined to be positive. Lagging power factor means PCS sinks reactive power from the grid and power factor is defined to be negative. The definition of power factor in this document is the same unless otherwise specified.

Power Factor / Active Power Characteristic Curve (PFP)

Table 21: Power Factor / Active Power Characteristic Curve (PFP)

Definition	Description	Unit	Min	Max	AS	VDE	NZS
Curve Point 1	Power point 1	%Prate	0	100	50	50	50
	PF point 1	NA	-1.00	1.00	1.00	1.00	1.00
Curve Point 2	Power point 2	%Prate	0	100	100	100	100
	PF point 2	NA	-1.00	1.00	-0.90	-0.90	-0.90

**Note:**

Before the function is enabled, the “Reactive Power Mode” must be set to “PFP”.

Appendix

Event Log Fault Definition

While the PCS detects a system error occurring, it will show the fault event name on its HMI screen at the front door, and users can also access the error code by communicating with the PCS via its protocol. The PCS system error codes consisting of DSP and MCU faults are listed in the tables below:

Fault Word Definition

Fault word format: 0 x 0 0 X X

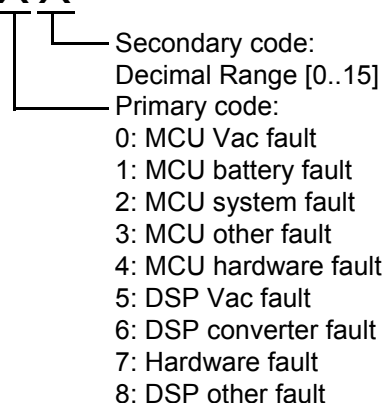

Figure 42. Fault Word Format

Table 22: Event Log Fault Code List

Fault Classification	Primary Code	Secondary Code	Fault Name (HMI Tool)	Fault Code (LCD Screen)
MCU Vac Fault	0	0	AC Phase R Over Voltage	AC OVP R
		1	AC Phase S Over Voltage	AC OVP S
		2	AC Phase T Over Voltage	AC OVP T
		3	AC Phase R Under Voltage	AC UVP R
		4	AC Phase S Under Voltage	AC UVP S
		5	AC Phase T Under Voltage	AC UVP T
		6	AC Over Frequency	AC OVER FREQ
		7	AC Under Frequency	AC UNDER FREQ
		8	AC Phase Sequence Error	PHASE SEQ ERR
		9	Synchronize Fault (PLL)	PHASE LOCK ERR
		A	NA	
		B	NA	
		C	NA	
		D	NA	
		E	NA	
F	Start Up Voltage Over Limit	GRID FAULT - SA		

Table 22: Event Log Fault Code List (Continued)

Fault Classification	Primary Code	Secondary Code	Fault Name (HMI Tool)	Fault Code (LCD Screen)
MCU Batt Fault	1	0	Battery Over Voltage Fault	BAT OVER VOLT
		1	Battery Under Voltage Fault	BAT UNDER VOLT
		2	Battery Input Revert	BAT POLE ERROR
		3	NA	
		4	Battery SoC Low Fault	BAT SOCL FAULT
		5	Battery SoC High Fault	BAT SOCH FAULT
		6	Battery SoC Low Warning	BAT SOCL WARN
		7	Battery SoC High Warning	BAT SOCH WARN
		8	Battery BMS Fault	BAT FAULT
		9	Battery Charge Power Over Limit Value Fault*	
		A	Battery Discharge Power Over Limit Value Fault*	
		B	NA	
		C	NA	
		D	NA	
E	NA			
F	NA			
MCU Sys Fault	2	Reserved		
MCU Other Fault	3	0	Ambient OTP	AMBIENT OTP
		1	Ambient UTP	AMBIENT UTP
		2	DRM0	DRM0
		3	DSP RS485 Loss	PM 485 Loss
		4	Slaver Under Fault State Fault*	
		5	NA	
		6	EEPROM Fault	EEPROM FAIL
		7	NA	
		8	NA	
		9	HMI RS485 Loss	HMI COM LOSS
		A	BMS CAN/RS485 Loss Fault	BMS COM LOSS
		B	PCS CAN Loss	SYS CAN LOSS
		C	PCS System Soft-Start Fault	SYS SOFTST FAIL
		D	System Restart Fault	SYS REST FAULT
		E	LC RS485 Loss	EMS_485_LOSS
F	4-20mA Data Fault*			

Table 22: Event Log Fault Code List (Continued)

Fault Classification	Primary Code	Secondary Code	Fault Name (HMI Tool)	Fault Code (LCD Screen)
MCU Hardware Fault	4	0	EPO Fault	EPO BUTTON
		1	Remote EPO Fault	REMOTE EPO
		2	AC Disconnecter Fault	AC BREAKER
		3	DC Disconnecter Fault	DC BREAKER
		4	SPD1 Fault	SPD FAULT
		5	Heat Fault	HEAT EXCHG FAIL
		6	NA	
		7	Fan Lock Fault	FAN LOCK
		8	NA	
		9	Aux Power Fault	AUX POWER 12V
		A	NA	
		B	NA	
		C	NA	
		D	NA	
		E	NA	
F	Door Open Fault	FRONT DOOR OPEN		
DSP Vac Fault	5	0	AC Phase R Over Voltage	AC OVP R
		1	AC Phase S Over Voltage	AC OVP S
		2	AC Phase T Over Voltage	AC OVP T
		3	AC Phase R Under Voltage	AC UVP R
		4	AC Phase S Under Voltage	AC UVP S
		5	AC Phase T Under Voltage	AC UVP T
		6	AC Over Frequency	AC OVER FREQ
		7	AC Under Frequency	AC UNDER FREQ
		8	AC Phase Sequence Error	PHASE SEQ ERR
		9	Synchronize Fault (PLL)	PLL LOST
		A	AC Phase R Over Load Light	OVER LOAD L1R
		B	AC Phase S Over Load Light	OVER LOAD L1S
		C	AC Phase T Over Load Light	OVER LOAD L1T
		D	AC Phase R Over Load Heavy	OVER LOAD L2R
		E	AC Phase S Over Load Heavy	OVER LOAD L2S
		F	AC Phase T Over Load Heavy	OVER LOAD L2T

Table 22: Event Log Fault Code List (Continued)

Fault Classification	Primary Code	Secondary Code	Fault Name (HMI Tool)	Fault Code (LCD Screen)
DSP Conv Fault	6	0	AC Phase R Over Current Fault (RMS)	AC OVER CUR R
		1	AC Phase S Over Current Fault (RMS)	AC OVER CUR S
		2	AC Phase T Over Current Fault (RMS)	AC OVER CUR T
		3	DC Bus (DC+ to DC-) Under Voltage Fault	DC BUS UVP
		4	DC Bus (DC+ to DC-) Over Voltage Fault	DC BUS OVP
		5	DC Bus Voltage (DC+ to Neutral Point) Under Voltage Fault	DC BUS UVP-P
		6	DC Bus Voltage (DC+ to Neutral Point) Over Voltage Fault	DC BUS OVP-P
		7	DC Bus Voltage (DC- to Neutral Point) Under Voltage Fault	DC BUS UVP-N
		8	DC Bus Voltage (DC- to Neutral Point) Over Voltage Fault	DC BUS OVP-N
		9	DC Bus Pre-Load Fail	DC PRE-ISSUE
		A	DC Side Soft-Start Fail	SOFT START FAIL
		B	DC Fuse Blown	DC FUSE BLOWN
		C	DC Discharge Over Current Fault	DC CHARGE OCP
		D	DC Charge Over Current Fault	DC DISCHG OCP
		E	Battery Bank Under Voltage Fault	BATT UVP
F	Battery Bank Over Voltage Fault	BATT OVP		

Table 22: Event Log Fault Code List (Continued)

Fault Classification	Primary Code	Secondary Code	Fault Name (HMI Tool)	Fault Code (LCD Screen)
Hardware Fault	7	0	EPO Fault	EPO BUTTON
		1	AC Fuse Fail	AC FUSE BLOWN
		2	Axillary Power	AUX POWER ERROR
		3	AC Pre-Load Contactor Fault	AC PRE-RELAY
		4	AC Main Contactor Fault	AC MAIN RELAY
		5	IGBT Short Fault	IGBT SHORT
		6	Sink Over Temp	HEAT SINK OTP
		7	MCU Fail	
		8	Fan1 Locked	FAN1 LOCKED
		9	Fan2 Locked	FAN2 LOCKED
		A	AC Hardware OCP	AC HARDWARE OCP
		B	DC Hardware OVP	DC HARDWARE OVP
		C	DC Hardware OCP	DC HARDWARE OCP
		D	NA	
		E	AC-Software-OCP	AC FW_OCP
F	Inductance L1 Over Temperature	L1 OTP		
DSP Other Fault	8	0	Ambient Over Temperature	AMB OVER TEMP
		1	Ambient Under Temperature	AMB UNDER TEMP
		2	Heat Sink Over Temperature	HEAT SINK OTP
		3	IGBT Over Temperature	IGBT OTP
		4	NTC Fail	NTC FAULT
		5	MCU 485 Loss	RS485 COM LOSS
		6	Grid Voltage Over Battery Voltage Fault*	
		7	CAN Loss	CAN COM LOSS
		8	ADC Calibration Fault	ADC CALIB ERROR
		9	EEPROM Fault	EEPROM ISSUE
		A	RAM Self-Test Fault	RAM TEST FAIL
		B	Anti-islanding	ISLANDING
		C	Phase Open/AC Connection Lost	AC OPEN PHASE
		D	Grid Recovering Fault	SYS RESTORING
		E	Internal Choke Current Imbalance	L1 Curr Unb
F	DCI Fault*			



Note:
The '*' means that fault code is only used for internal use.

Fault Word Example

For Example: LOG1 fault word is 0x007B, primary code '7' means "Hardware Fault", then you can get "DC Hardware OVP" from fault classification "Hardware Fault" according to secondary code 'B'. Corresponding to the fault information on the PCS LCD Screen is "DC HARDWARE OVP".

Human Machine Interface Display

Keypad Button & Home Panel

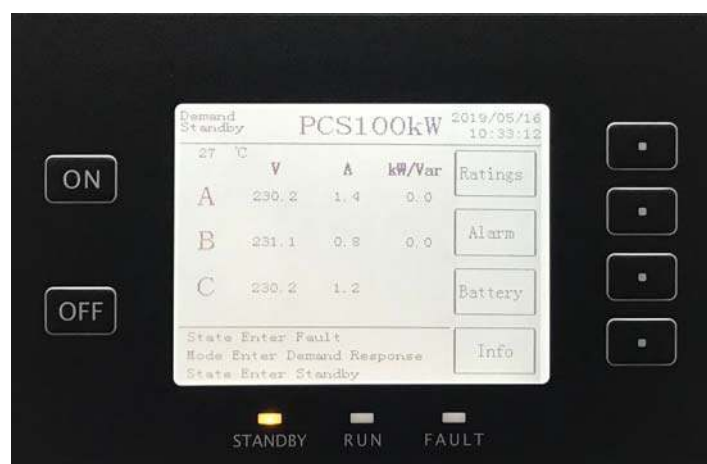

Figure 43. Keypad Button & Home Panel

Table 23: Keypad Button & Home Panel

No.	Item	Description
1	ON	On (The button is disable)
2	OFF	Off (The button is disable)
3	STANDBY	Standby state
4	RUN	Run state
5	FAULT	Fault state
6	Demand	Configured for demand mode
7	Standby	Standby state
8	100kW	Power conditioning system 100kW
9	Ratings	Ratings
10	Alarm	Alarm
11	Battery	Battery
12	Info	Information
13	V	Voltage
14	A	Ampere
15	kW/Var	Kilowatt/Variants
16	State Enter Running	State enter running
17	State Enter Standby	State enter standby

Table 23: Keypad Button & Home Panel (Continued)

No.	Item	Description
18	A	Grid phase 1: L1
19	B	Grid phase 2: L2
20	C	Grid phase 3: L3

Ratings Panel

**Figure 44. Ratings Panel****Table 24: Ratings Panel**

No.	Item	Description
1	Ratings	Ratings
2	HOME	Return to home page
3	AC L-L VOLT (V)	AC line-line voltage (V)
4	FREQUENCY (Hz)	Frequency (Hz)
5	AC CURRENT (A)	AC Current (A)
6	VDC IN LOW (V)	VDC in low (V)
7	VDC IN HIGH(V)	VDC in high (V)
8	DC CURRENT (A)	DC current (A)
9	AC POWER (kW)	AC power (kW)

Alarm Panel



Figure 45. Alarm Panel

Table 25: Alarm Panel

No.	Item	Description
1	Alarm	Warning & fault
2	HOME	Return to home page
3	BMS COM LOSS	BMS communication loss

BATT INFO Panel



Figure 46. BATT INFO Panel Page 1

Table 26: BATT INFO Panel Page 1

No.	Item	Description
1	BATT INFO	Battery information
2	HOME	Return to home page
3	NEXT	Next page
4	State	State
5	PwrOff	Power off

Table 26: BATT INFO Panel Page 1 (Continued)

No.	Item	Description
6	V	Voltage
7	I	Current
8	V	Volt
9	A	Ampere
10	P	Power
11	kW	Kilowatt
12	SoC	State of charge
13	%	Percentage
14	SoH	State of health
15	Temp	Temperature
16	°C	Celsius
17	MC_N	Main contactor -
18	MC_P	Main contactor +
19	PC	Pre-charge contactor
20	AllClsd	All closed
21	AllOpen	All open
22	LGC	LG chemical
23	LossCOMM	Communication loss
24	BMS	Battery management system

**Figure 47. BATT INFO Panel Page 2****Table 27: BATT INFO Panel Page 2**

No.	Item	Description
1	RACK1, RACK2, RACK3	Battery rack
2	ST	Status

Table 27: BATT INFO Panel Page 2 (Continued)

No.	Item	Description
3	Initial	Initial
4	Open	Open
5	Close	Close
6	MC+	Main contactor +
7	MC-	Main contactor -
8	PC	Pre-charge contactor
9	V	Voltage
10	I	Current
11	SoC	State of charge
12	PM+	Power discharge limitation
13	PM-	Power charge limitation

**Figure 48. BATT INFO Panel Page 3****Table 28: BATT INFO Panel Page 3**

No.	Item	Description
1	Max Cell Volt	Maximum cell voltage
2	Min Cell Volt	Minimum cell voltage
3	Max Cell Temp	Maximum cell temperature
4	Min Cell Temp	Minimum cell temperature
5	V	Voltage
6	°C	Celsius



Figure 49. BATT INFO Panel Page 4

Table 29: BATT INFO Panel Page 4

No.	Item	Description
1	AIRC	Air conditioning
2	DOOR	Door
3	SPD	Surge protection device
4	HEAR	Heat exchanger
5	Falt	Fault
6	OPEN	Open
7	Ext Batt Cab absent	External battery cabinet absent
8	Fault	No fault
9	Norm	Normal

Info Panel



Figure 50. Info Panel Page 1

Table 30: Info Panel Page 1

No.	Item	Description
1	Info	Information
2	HOME	Return to home page
3	HW	Hardware
4	FW	Firmware
5	DVT version	Design verification test version
6	M/P/H	MCU/DSP/HMI
7	Designed by	Designed by
8	NEXT	Next page



Figure 51. Info Panel Page 2

Table 31: Info Panel Page 2

No.	Item	Description
1	HOME	Return to home page
2	BACK	Return last page
3	UP	Increase the value
4	DN	Decrease the value
5	LCD CONTRAST RATIO ADJ	LCD contrast ratio adjustment
6	SET VALUE	Set value