

U P S

On-Line

1KVA-3KVA

■ **USER MANUAL** ■

EMC Statement

These products are tested and thereby comply with the conditions of CE regulation, which establishes to offer sufficient protection against dangerous interference for installation. Installation and use of the equipment should comply with the instructions provided to avoid such interference due to the amount of radiofrequency energy that generates by the equipment; Despite this, we cannot assure that a certain amount of interference may not occur in some installations.

If by turning on and off, you conclude that the equipment's harmful interference influences your radio or television reception, use one of the following preventive measures:

- Place the receiving antenna in a separate location or orientation
- Ensure a greater distance between the receiver and the equipment
- Ensure that your equipment connects to an outlet on a separate circuit
- Contact a technician experienced with radio and TV or a dealer for technical assistance

Declaration of Conformity Request

Units labelled with a CE mark comply with the following standard and directives:

- EMC Directive 2014/30/EU
- LVD Directive 2014/35/EU
- Safety: EN 62040 - 1
- EMC: EN 62040 - 2

The EC Declaration of Conformity is available upon request for production with a CE mark.

Table of content

| | |
|--|----|
| EMC Statement..... | 1 |
| 1. IMPORTANT SAFETY INSTRUCTIONS | 3 |
| 2. Introduction | 4 |
| 3. Installation | 4 |
| 3.1. Hardware Installation..... | 4 |
| 3.2. Rear panel view (For reference only) | 5 |
| 3.3. EPO port | 6 |
| 3.4. Connection to External Battery Pack..... | 6 |
| 3.5. Automatic battery pack detection | 6 |
| 3.6. Connection to Main and Load | 6 |
| 4. Operation..... | 7 |
| 4.1. General Description..... | 7 |
| 4.2. System Configuration | 8 |
| 4.3. Front Panel Operation..... | 8 |
| 4.3.1. Button Operation | 8 |
| 4.3.2. Screen Angle Adjustment..... | 9 |
| 4.4. UPS Display..... | 9 |
| 4.4.1. Home Page Introduction | 10 |
| 4.4.2. UPS Information Page | 12 |
| 4.4.3. Battery Information Page..... | 12 |
| 4.4.4. Input / Output Setting Page (include the load segment)..... | 12 |
| 4.4.5. Mode Setting Page | 13 |
| 5. UPS Monitoring Connection | 13 |
| 5.1. Connect UPS to Computer with USB (Optional)/RS232 port. | 13 |
| 5.2. Connect UPS with interface Slot (Optional) | 13 |
| 5.3. UPS RS232 PORT..... | 14 |
| 5.4. Dry Contacts with Relay | 14 |
| 6. Maintenance..... | 14 |
| 6.1. Transportation..... | 14 |
| 6.2. Storage | 14 |
| 6.3. Operation | 15 |
| 6.4. Battery..... | 15 |
| 6.4.1. Maintenance | 15 |
| 6.4.2. Replacement | 15 |
| 6.4.3. Internal Battery Detection | 16 |
| 6.4.4. External Battery Pack..... | 16 |
| 6.4.5. Maintenance Bypass Procedure | 16 |
| APP-A. Trouble Shooting..... | 17 |
| APP-B Technical Specifications | 18 |

1. IMPORTANT SAFETY INSTRUCTIONS

WARNING: SAVE THESE INSTRUCTIONS!!

- **WARNING (SAVE THESE INSTRUCTIONS):** This manual contains important instructions that should be followed during installation and maintenance of the UPS and batteries. The equipment can be operated by any individuals with no previous experience.
- **WARNING:** It is highly recommended to install the product in a controlled environment; maximum ambient temperature is 40°C.
- **WARNING:** It is recommended to install UPS in an ANSI/NFPA75 room in which temperature and humidity are controlled and free from electrically conductive particles. **DO NOT** expose UPS to direct sunlight or high heat source; **DO NOT** block off ventilation opening around the housing.
- **CAUTION:** Before conducting maintenance, repair, or shipment, please turn off everything completely and disconnect them.
- **CAUTION:** The UPS is **NOT** applicable for any inductive loads such as motors or domestic appliances like hairdryers, speakers, and fluorescent lamps.
- **CAUTION:** All interconnection and power cable should be connected **ONLY AFTER** the UPS shut down and disconnected from main.
- **CAUTION:** Only use No.26 AWG or larger certified cables to connect UPS and device
- **CAUTION: DO NOT** unplug UPS from main power during operation or protective ground will fail. **DO NOT** disconnect battery under load or shut down may occur.
- **CAUTION:** Ensure the total leakage current of UPS and the connected equipment under 3.5mA.
- **CAUTION:** Ensure UPS connects to grounded main power with a fuse or circuit breaker protection.
- **CAUTION:** Dangerous amount of voltage might still exist even the UPS disconnects from the main power since residual voltage exists due to battery supply.
- **CAUTION:** Beware of all the details on the cautionary sticker located on UPS.
- **CAUTION (No user-serviceable parts):** Do not attempt to remove the unit's cover, no user-serviceable parts inside. Please refer all service to qualified service technicians.
- **CAUTION: DO NOT** dispose of batteries in a fire. The batteries may explode.
- **CAUTION: DO NOT** open or mutilate batteries. Released electrolyte is harmful to the skin and eyes. It may be toxic.
- **User's operations:** Users only permits to:
 - Turning the UPS unit on and off.
 - Operating the user interface.
 - Connecting data interface cables.
 - Changing the batteries (For rack type ONLY)
- **CAUTION:** A battery can bring risk of electric shock and high short circuit current. Contact with any part of a grounded battery can result in electrical shock. The following precaution should be observed when working on batteries:
 - A. Remove watches, rings, or other metal objects.
 - B. Use tools with insulated handles.
 - C. Wear rubber gloves and boots.
 - D. Do not lay tools or metal parts on top of batteries.
 - E. Disconnect charging source and load prior to installing or maintaining the battery.
 - F. Remove battery grounds during installation and maintenance to reduce likelihood of shock. Remove the connection from ground if any part of the battery is determined to be grounded. Servicing of batteries should be performed or supervised by personnel with knowledge of batteries and the required precautions. Keep unauthorized personnel away from batteries.
- **DANGER:** Hazardous electric component inside this unit (example: Heat-sinks) remain energized from the battery supply even when the main power is disconnected.
- **DANGER:** Battery circuit is not isolated from the AC input. Hazardous voltage may exist at battery terminals and ground -- Test for safety before any direct contact.
- **CAUTION:** Remove the battery's pole during service inside the battery cabinet or UPS.
- **CAUTION:** When replacing batteries, replace with the same type and number of batteries: **One Sealed lead acid battery, rated 12 V, 9 AH max.**
- **WARNING (Fuses):** Ensure fuse replacement with the same type and rating **ONLY**.

2. Introduction

The information provided in this manual covers the **ON-LINE UPS 1KVA-3KVA** uninterruptible power system (UPS). This manual contains basic functions, operating procedures, and emergencies, also including information on how to ship, store, handle, and install the equipment.

Only detailed requirements of the UPS units described herein. The installation must carry out according to this manual. The electrical installation must further comply with local legislation and regulations.

3. Installation

3.1. Hardware Installation

Rack Tower Stand Installation

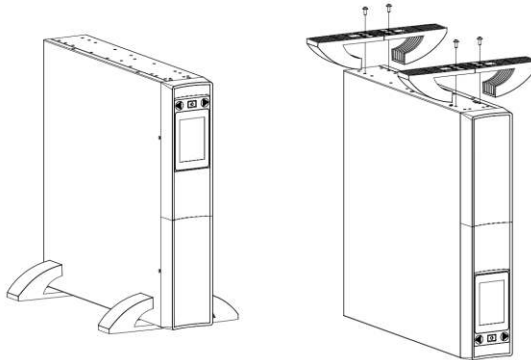

Fig.3.1.1 The installation diagram of UPS rack stand. Screws are provided to fix the position of the rack stand.

Rack Mounting Ear Installation

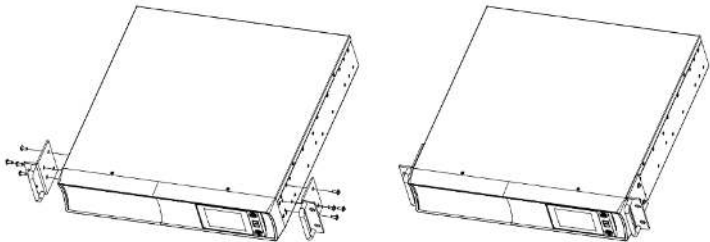
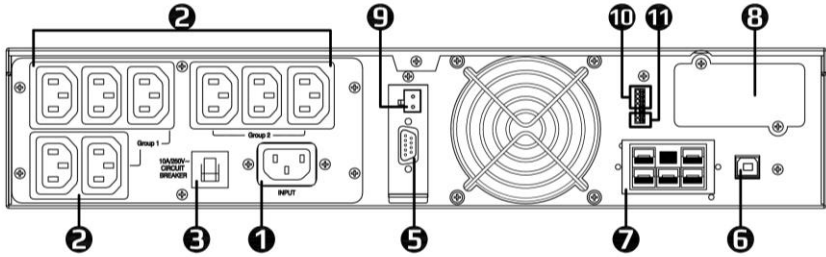

Fig.3.1.2 The installation diagram of UPS rack mounting ear. Screws are provided to fix the position of the rack mounting ear.

3.2. Rear panel view (For reference only)
1K-1.5KVA



IEC Type

2KVA

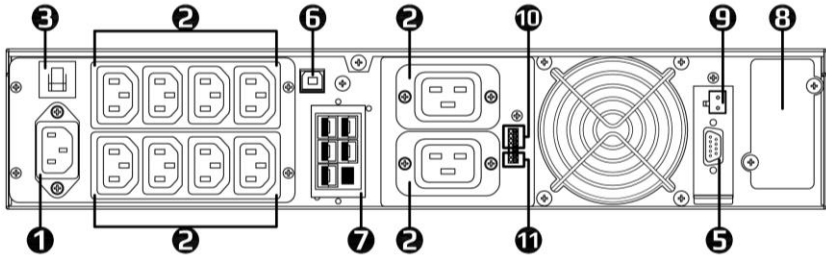

IEC Type

3KVA

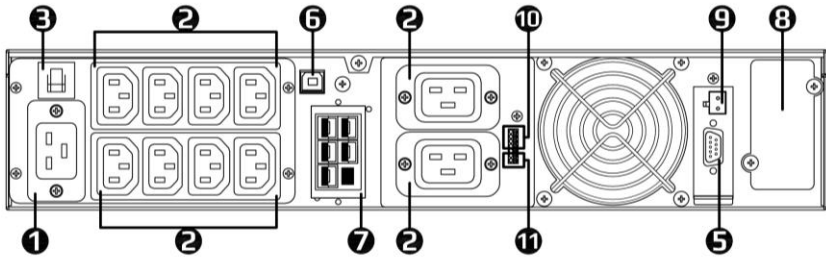

IEC Type

- 1** Input
- 2** Outlet
- 3** Input breaker
- 4** Network transient protector
- 5** RS232 port
- 6** USB
- 7** External battery port (optional)
- 8** Interface port (optional)
- 9** EPO
- 10** Dry contact
- 11** Battery pack detection

***Figures only display available function; functions are not on unit if not marked.**

3.3. EPO port

The Emergency Power Off (EPO) port can quickly cut off the output power of the UPS. Remote controls can be applied to the port so UPS could shut down its output in the event of an emergency. Since EPO shuts down the UPS immediately without regular procedure and monitoring, UPS will require a manual restart to restore its operation.

3.4. Connection to External Battery Pack

- External battery connections shall be installed by service personnel **only**.
- Please read safety instructions first before proceeding.
- Ensure UPS disconnects from all main and loads before attempting.
- Locate the battery connector, then use **only** factor-supplied or authorized battery cable provided to connect the UPS with the battery as fig.3.3 below.
- Connect the second battery to the first one if more than one is needed.

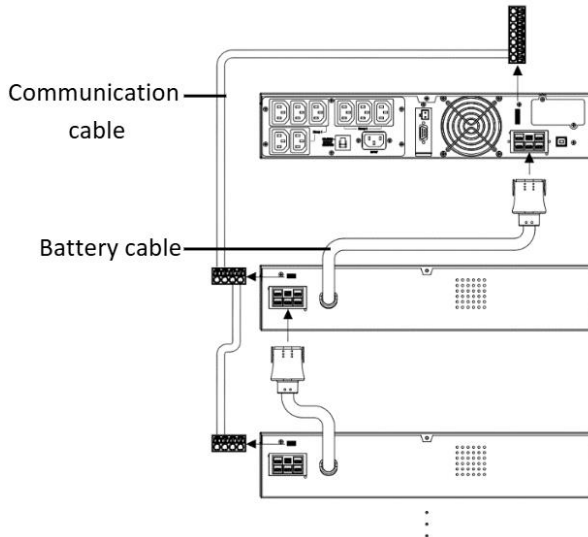

Fig.3.3 Please follow the above diagram while connecting external battery packs.

3.5. Automatic battery pack detection

When the host requires a longer discharge time, a dedicated battery pack must be purchased. When the battery pack is connected to the host, a communication cable must be connected, so that the host can automatically detect that the battery pack has been added, and the discharge time will also be automatically calculated. The current design can add five battery packs, and each battery pack must be connected to a communication line.

3.6. Connection to Main and Load

- Follow all installation and safety instructions very carefully; failure to do so may cause hazardous situations to personnel and equipment.
- Ensure the main power voltage matches with UPS. (110V/220V)
- Closely observe the nominal current rating of electrical source for installation.
- Check the equipment's power requirement to prevent overloading situations.

- Do not connect devices that draw either massive power shortly or half-wave rectified current - such as hairdryer, vacuum cleaner, laser printer, and plotter.
Note: Although you may use the UPS immediately, maximum back up time will not be available yet. It is recommended to charge the batteries for a minimum of 8 hours before use.
- Connect the input cable to the UPS and the other end to the mains. The battery will automatically charge when UPS is connected to the main power.
- After charging the UPS, connect the load to the UPS.
- Should computer or alarm connections be used, refer to the UPS monitoring connection chapter for further detail.
- The installation is complete.

4. Operation

4.1. General Description

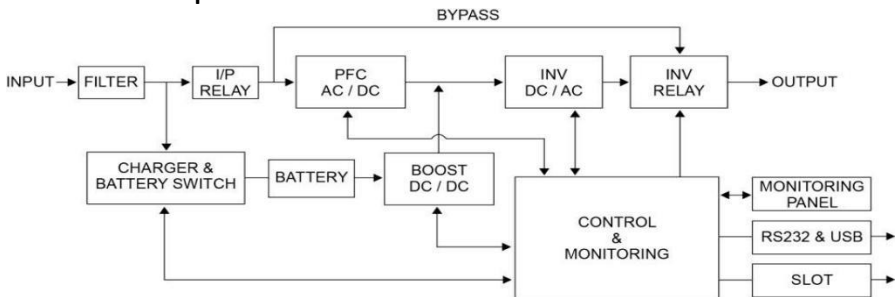

As double conversion On-line UPS, it can convert clean single-phase power to support your critical system. The diagram of UPS is as shown above.

- Input filter reduces transients and interference from the main
- With PFC AC/DC, AC-power is rectified and regulated to DC power
- DC power is converted to AC in the inverter passing it on to the load

Line-Mode/Battery-Mode

UPS will operate in Line-Mode that supports power and charge battery while connected to power. During a power failure, the UPS will switch to Battery-Mode, in which power is maintained from the battery. In case of failure time exceed Battery-Mode duration, UPS will shut down until voltage return to prevent battery discharge.

Free Run Mode

Free Run Mode provides a wider input frequency range when input frequency does not match the selected range (user adjustable). Free Run Mode enlarges input frequency acceptance up to 45Hz ~ 65Hz but fixes output frequency to 50Hz(220V) and 60Hz(110V) with $\pm 0.25\text{Hz}$. Free Run Mode designs for large power variation. It is activated in default and can run with Line-mode simultaneously.

High-Efficiency Mode

High-Efficiency Mode designs to minimize power loss and power consumption. Whenever power is stable, UPS will automatically switch to bypass for efficiency. When any irregularity is detected, Line-Mode will reactivate immediately. Switching occurs when the input voltage is outside $\pm 10\%$ of nominal ($\pm 15\%$ selectable), input frequency is outside of $\pm 3\text{Hz}$, or when no input line is available.

You can also activate this mode from the LCD panel. Refer to UPS configuration.

Diagnostic Test

The diagnostic test automatically executes to check and report UPS status. While the advanced battery management system monitors the conditions of the batteries, it sends early warnings if a battery replacement is needed. Diagnostic tests can also activate by manual control.

Generator mode

This mode designs for highly unstable power. In this mode, UPS normal operation will not transfer to bypass to prevent load damage and frequent battery discharge. UPS will also fix output frequency to 50Hz(220V) or 60Hz(110V) with $\pm 0.25\text{Hz}$. Users can set the UPS to bypass/shutdown whenever UPS malfunction occurred.

Generator Mode can activate from the LCD panel too.

4.2. System Configuration

The UPS device and battery make up the system. Depending on site and load requirements, certain additional options are available as tailored solutions. Please consider the following when planning your UPS system:

- The total demand for the protected system shall dictate the output power rating (VA). When measuring demand, please allow a margin for future expansion and calculation error.
- Battery-mode duration needs dictate the battery size. If the load is less than the UPS nominal power rating, then the actual backup time is longer.
- The following options are available:
 - Connectivity options (relay card, SNMP/WEB card)
 - External battery packs
 - Transformer cabinets
 - Maintenance bypass switches

4.3. Front Panel Operation

4.3.1. Button Operation

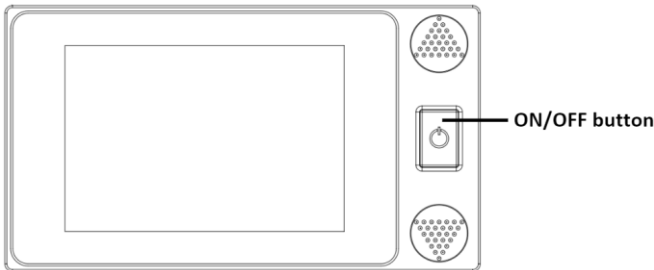



Cold Start Function

When the main power is not connected to UPS, it is capable of starting with battery power for users' needs. Simply start the UPS as the instruction below.

Note: To avoid accidental battery discharge, cold start function is not available until the initial connection to the main power.

"ON/OFF" button

- (a) Press and hold the "" button for 3 seconds to turn on the UPS.
- (b) Press and hold the "" button for 3 seconds to turn off the UPS while UPS is working.

Turn On the UPS

- Ensure installation is correct and successful, and connect the input power cable to a well-grounded outlet.
- Push the “on/off” button on the front panel for 3 seconds.
- After the UPS is turned on, the splash screen will last for 6 seconds.
- UPS should start its inspection of internal function, main synchronization, and inverter startup. The LCD panel will display “Line-Mode” indication and power should start supplying via the outlets.
- Switch on the loads.

Shut Down the UPS

- Shut down and turn off all the loads.
- Press the “On/Off” button for 3 seconds. UPS will shut down with an alarm.
- (If applicable) To avoid electrical hazards, please turn off the internal/external input breaker after the display disappeared, and only the backlight remains. Then, turn off any external battery breaker and wait till all fans completely shut down.
- In an emergency, use the EPO located on the rear panel.

4.3.2. Screen Angle Adjustment

This UPS has a user-friendly design, and the screen angle can be adjusted to make it easier for users to obtain information. To switch to different angles, gently push the edge of the screen. When you no longer operate the UPS screen, please return the screen to a position flush with the panel to avoid accidents.

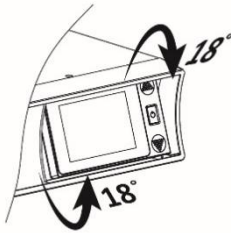

Adjustable screen angle

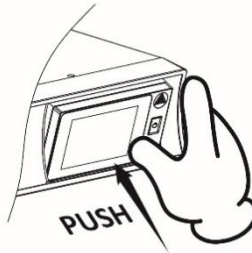

Gently push the edge of the screen



When not in use, return the screen to a position flush with the panel

4.4. UPS Display

Touch screen is applied to this UPS as the Human-Machine interface. To operate this device, please use your fingertips or tools that will not damage the screen. If the screen is dirty or has poor contact, please wipe it with clean cloth before operating it.

The touch screen will automatically switch to Home Page after 3 minutes of inactivity. And the screen will go black after 2 minutes to save energy. When Warning or Fault occurs, the touch screen will be forced to turn on and will not switch to Home Page.

During the Fault state, tap anywhere of the screen to switch to the UPS Information Page. If you return to the Home Page while Fault occurs, the touch screen will switch to Fault state after 5 seconds.

4.4.1. Home Page Introduction

The home page shows the information of output voltage, battery power, load level, outlet segment and UPS status. Both normal and warning status are shown with icon in status column. And warning status are especially in red to point out the UPS could no longer protect your device until the problem is solved. Figure 4.4.1 shows the touch-sensitive area for going to other pages. For the meaning of the icons, please refer to Table 4.4.1

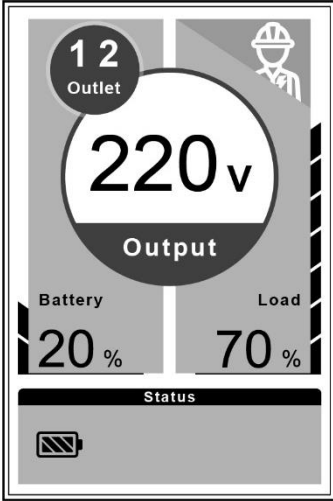

Home page with normal status
(Tower Display)

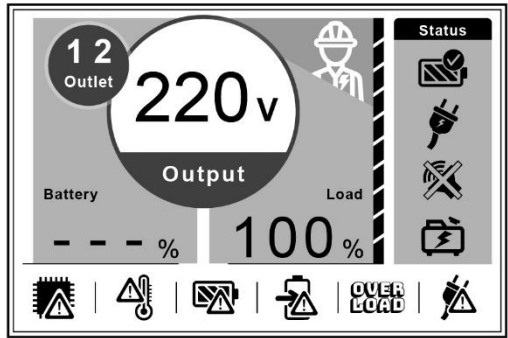

Home page with warning status
(Rack Display)

Detailed Icons Description

| Icons | Function Description | Icons | Function Description |
|----------------------------|---|-------|--|
| Normal Status Icons | | | |
| | Connected to Mains UPS is connected with input Power | | Line Mode System operating normally with Mains power |
| | Battery Mode The UPS transfers to battery mode if the mains supply fails | | Silence Mode UPS silence mode Enabled |
| | Battery Test UPS is conducting a battery test | | Generator Mode UPS is operating on Generator mode |
| | High-Efficiency Mode UPS is operating under high-efficiency mode | | EPO Emergency Power Off |
| | Bypass No UPS protection is applied at this moment. Power goes directly from mains to equipment | | |













| Warning Status Icons | | | |
|---|---|---|---|
|  | <u>Manual Bypass</u> Power is supplied bypassing the UPS manually (maintenance only) |  | <u>Overload</u> UPS suffers an overload problem Output exceeds UPS capacity |
|  | <u>Wire Fault</u> There is a problem with the ground and live wires |  | <u>Battery Failure</u> The battery is not connected to the UPS |
|  | <u>Overcharge</u> Abnormal battery voltage |  | <u>Line Abnormal</u> Mains power abnormality during Auto Restart |
|  | <u>Charger Fail</u> Battery cannot be charged |  | <u>Over Temperature</u> Please reconfirm the UPS operating environment |
|  | <u>Communication Loss</u> |  | <u>AC Fail</u> AC input fails, UPS switches to Battery Mode |
|  | <u>BusFault</u> BUS failure |  | <u>High Output Voltage</u> The output voltage is too high |
|  | <u>Low Output Voltage</u> The output voltage is too low | | |

Table 4.4.1

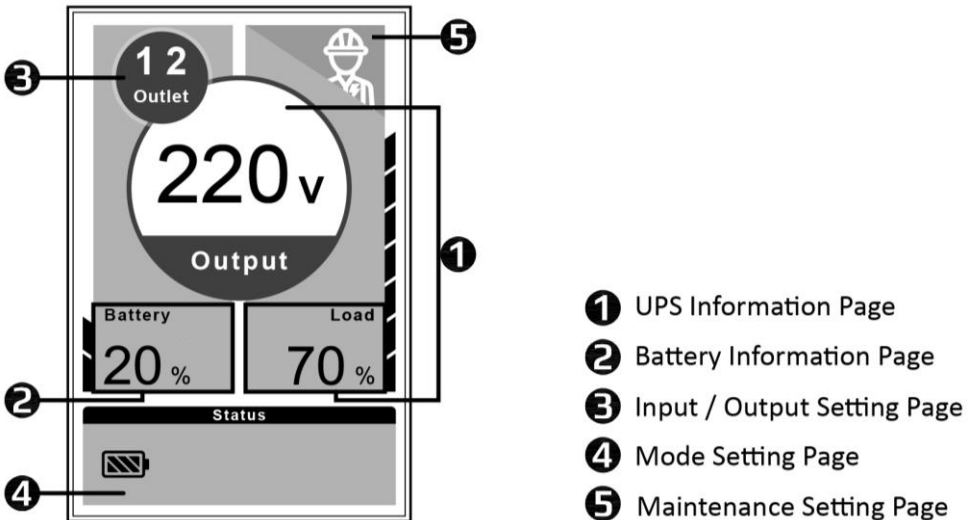

Fig.4.4.1

4.4.2. UPS Information Page

This contains three pages, the Output Information, Input Information, and UPS Machine Information. The Output Information Page and Input Information Page provide detailed information about the output and input power of the UPS. The UPS Machine Information Page provides information about this UPS. Click Exit in the lower left corner to return to Home Page.

| Input | UPS | Output |
|---------|--------|--------|
| Voltage | 215.0V | |
| Freq. | 50.0Hz | |

< Close Input Information

| Input | UPS | Output |
|-------------|------------|--------|
| Voltage | 220.0V | |
| Current | 10.0A | |
| Freq. | 60.0Hz | |
| Power(W) | 20000W | |
| Power(VA) | 20000VA | |
| Load | 100% | |
| Dissipation | 9999BTU/hr | |

< Close Output Information

| Input | UPS | Output |
|---------------------|-------------|--------|
| Model | SNT-3K | |
| Serial No. | 12345678901 | |
| UPS Ver. | 12345 | |
| Display Ver. | 0123456789 | |
| Date of Manufacture | 23/07/20 | |
| UPS temp. | 30°C | |

< Close UPS Information

4.4.3. Battery Information Page

The Battery Information Page provides detailed battery information, allows you to perform battery tests and enter the number of battery packs connected to this UPS. Click Exit in the lower left corner to return to Home Page. To perform a battery test, click the Test button, then wait until the progress bar is full and the status is no longer "Testing". If the status shows fail, please seek professional assistance to maintain the protection of UPS to your equipment.

| | |
|--------------|--------|
| Status | Normal |
| Voltage | 72.0V |
| Remain time | 532min |
| Level | 98% |
| Battery Pack | 0 |
| Test | 0% |

< Close Battery Information & Setting

| | |
|--------------|---------|
| Status | Testing |
| Voltage | 72.0V |
| Remain time | 532min |
| Level | 98% |
| Battery Pack | 0 |
| Test | 100% |

< Close Battery Information & Setting

4.4.4. Input / Output Setting Page (include the load segment)

This page contains two pages, the Output Setting and Input Tolerance Setting. These pages provide users with options to adjust the UPS Input Tolerance and Output Power according to actual conditions. Click Exit in the lower left corner to return to Home Page.

To set the Load Segment, click Output Setting and set Group 1 or Group 2 to ON or OFF.

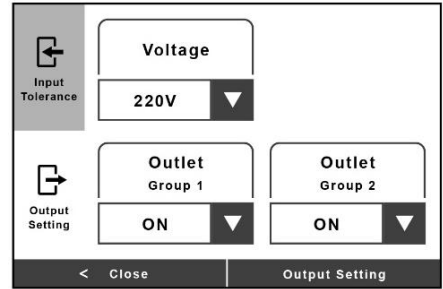
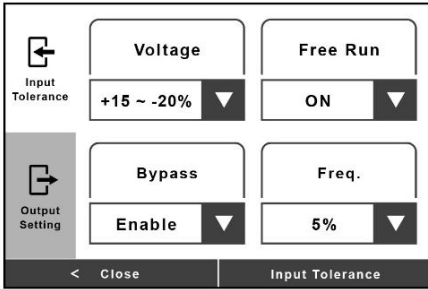

4.4.5. Mode Setting Page

You can choose to enable or disable many functions of the UPS in this Mode Setting Page. So that UPS could perform its system as you wish. Click Exit in the lower left corner to return to Home Page.

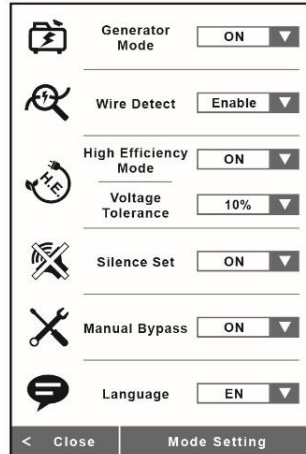

5. UPS Monitoring Connection

UPS monitoring software (or other power monitoring software) can further utilize the UPS with warning reminders, monitoring, control shut down, and setting adjustments. UPS must connect to a computer or the internet to use the monitoring feature.

5.1. Connect UPS to Computer with USB (Optional)/RS232 port.

- Locate the USB/RS232 port on UPS.
- Connect with factory-provided/approved communication cable.
- Ensure your computer can install and support power management software.
- **Note:** Either USB Port or RS232 port, only one port will function at a time.

5.2. Connect UPS with interface Slot (Optional)

- **SNMP Card** allows UPS management and monitoring over a network or internet.
- For more information, please contact for technical assistance.
- **AS400 Card** allows voltage free relay contacts.

5.3. UPS RS232 PORT

- The RS-232 interface uses a 9-pin female D-sub connector.
- The RS-232 port carries the data about utility, load, and UPS.
The interface port pins and their functions are in the following table

|  | | | |
|---|--------|-----------|--------------------------|
| Pin # | Signal | Direction | Function |
| 2 | TxD | Output | TxD Output |
| 3 | RxD | Input | RxD / Inverter Off Input |
| 5 | Common | | Common |

Caution! Max rated values 12VDC

5.4. Dry Contacts with Relay

This UPS provides two dry contact signals for users to use, and this uses a relay design, which can withstand larger energy signals, so there is no need to purchase additional relay cards. This UPS provides two signals, line fail and battery low, for users to use. Users can wire according to the instructions in Table 5.4 to connect external devices.

| PIN # | Description | I/O type |
|-------|---|----------|
| 1 | Utility fail, normally open, active close | output |
| 2 | Battery low, normally open, active close | output |
| 3 | Common | |
| 4 | GND for secondary | |

Table 5.4

6. Maintenance

Please read the following instruction to ensure your safety and maintain a longer product lifetime. This section contains detailed information about moving, maintaining, and placing the UPS. With a minimal amount of maintenance, you can expect the UPS to function smoothly.

6.1. Transportation

Please handle UPS with extreme caution since the battery contains a high amount of energy. Keep the unit in position as marked on the packaging and never drop the unit.

6.2. Storage

Please read the following instructions if the UPS is not installed immediately:

- Store the equipment as is in its original packing and shipping carton.
- Do not store in temperatures outside the range of +15°C to +25°C.
- Fully protect the UPS from wet or damp areas and moist air.
- To maintain the vitality of the batteries recharges the UPS at least 8 hours every 6 months.

6.3. Operation

CAUTION: Ensure that all environmental concerns and requirements are met according to safety instruction; otherwise, the safety of installation personnel cannot be guaranteed since the unit may malfunction.

- Please ensure no flammable substances such as gases or fumes.
- Avoid extreme temperature and humidity. Protect the equipment from moisture.
- Ensure there is enough space (300mm or above recommended) at the rear and side of UPS for proper ventilation.
- Ensure that the front of the UPS remains clear for user operation.
- **Only** authorized agents or technicians may service the unit.
- **Do not** open the UPS cabinet. Components may contain hazardous or fatal voltage.
- Output receptacles may carry live voltage without connecting to the main power.
- Pay special attention to UPS air inlet; **do not** let it cover by dust.

6.4. Battery

6.4.1. Maintenance

The reliability of the battery is heavily related to the environmental issue. At the temperature of 25 degrees Celsius, a regular 6-12 months' check-up is advised.

6.4.2. Replacement

1K-3KVA

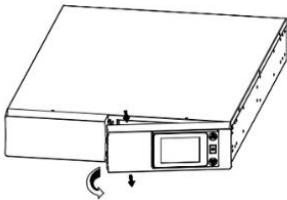

Remove the front panel

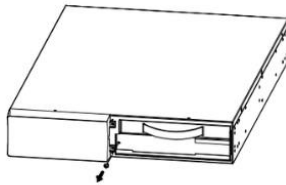

Remove the screw and metal battery cover

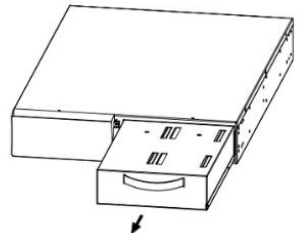

Disconnect the battery wires and pull out the battery box

1. Hold the **display-side** front panel corner, then pull out lightly as arrow indicated. Then, push to the side to unlock the other tenon.
2. Remove the battery cover, disconnect battery cable, then remove the battery.
3. Replace with the same type and quantity of battery,
4. Reinstall the new battery and push it into the UPS.
5. Reinstall the battery cover. Reinstall the front panel.

Note: Tower model battery replacements are not available by users. Please contact for technical assistance.

6.4.3. Internal Battery Detection

To ensure complete protection for the equipment connected to the UPS, the UPS applied an Internal Battery Detection function. That is, when no internal battery is connected to the UPS, the UPS will activate an audible alarm and display a "Battery Failure" icon on the LCD screen to notify the user that the UPS is currently not providing protection. Users should immediately seek assistance from a professional UPS technician and obtain a compatible internal battery. Once the battery is properly installed, the audible alarm and "Battery Failure" icon will be deactivated, restoring the UPS's ability to provide full power protection to the connected equipment.

6.4.4. External Battery Pack

The following chart is the recommended specification of the external battery pack/cabinet. For other options, please ensure that the option meets safety instruction and local legislation.

Note: when power supplies by external batteries, output loads will be limited to 90% for overall power generation.



| Model | 1000 | 1500 | 2000 | 3000 |
|--|----------------|------|----------------|---------------|
| Battery Type | 12V 7Ah | | | 12V 9Ah |
| Number of Batteries | 6 | | 12 | 12 |
| Back-up time /Full load (min)(Battery Pack Only) | Approx. 13-15 | | Approx. 13-15 | Approx. 13-15 |
| Typical Recharge time | <8 hrs to 90% | | | |
| Dimensions WxDxH (mm) | 428 x 435 x 84 | | 428 x 645 x 84 | |
| Net Weight (kgs) | 21.3 | | 39.7 | |

6.4.5. Maintenance Bypass Procedure

Maintenance

1. Make sure the UPS is running.
2. Switch to the mode setting page.
3. Set Manual Bypass in the lower left corner to "ON".
4. Make sure the home page displays this icon 

Restore

1. Confirm that this icon  appears on the main page then switch to the mode setting page.
2. Set Manual Bypass in the lower left corner to "OFF".
3. Make sure the icon  on the home page is gone.

APP-A. Trouble Shooting

Troubleshooting procedures give simple instructions in determining UPS malfunctions. Start the troubleshooting procedure if you witness any alarm indication.

Alarm

The UPS has an audible alarm. When different situations occurred, UPS will alert users with display and buzzer.

Please refer to the troubleshooting chart for detail information

Silencing Alarm

Here is the instruction to mute alarm or future alarm notification:

Note: During battery-mode, if the battery is low on power, the alarm will sound regardless of silent-mode enable/disable.

Silent Mode: configure on LCD to enable/disable all audio malfunction warning.

Normally, the input of mains will light up the backlight.

If troubleshooting does not include or resolve your situation, feel free to contact for technical assistance.

| Situation | Alarm & Display | Description & Solution |
|---------------------|-------------------------------|--|
| High Output Voltage | Constant beep | High output voltage Please contact for technical assistance |
| Low output Voltage | Constant beep | Low output voltage Please remove the load and restart the UPS. If it does not work, Please Contact for technical assistance |
| Output short | Constant beep | Output short circuit Please contact for technical assistance |
| Bus fault | 2 beep/seconds | High internal DC bus Voltage Please contact for technical assistance |
| Over-temperature | Constant beep | High surrounding temperature Ensure fan operational and ventilation clear Contact for technical assistance If the problem remains |
| Set wiring fault | 1 beep/seconds | Wrong UPS input wiring between natural and line, turn the plug 180 degrees and plug it in |
| Output overload | 2 beep/seconds | Connected equipment power requirements exceed UPS provision. UPS will switch to bypass mode when overload in Line-mode. Shut off less essential equipment connected to UPS. UPS automatically switches back to normal when the problem resolves. |
| Over-charge | Constant beep | Battery overcharged, Turn off UPS and contact for technical assistance |
| Charger failure | N/A | The charger has failed. Contact for technical assistance |
| Battery failure | 3 beep/5 seconds | The battery has failed. Contact for technical assistance |
| Line abnormal | 1beep/seconds | Wrong AC line backed up during auto restart Please reconfirm your main power and frequency |
| Battery test | N/A | UPS battery test processing. UPS will return to normal operation after completion. No action needed |
| Battery mode | 1 beep/5 seconds with display | Unit is operating with battery power, secure your data and perform a controlled shutdown |
| Low battery | 2 beep/5 seconds with display | UPS will shut down due to low battery voltage. The unit will restart automatically when sufficient power returns |
| *Bypass mode | N/A | When the bypass mode is displayed *Please turn off the UPS before removing the input power, and contact for technical assistance |

APP-B Technical Specifications

| Rack Model | | 1000 | 1500 | 2000 | 3000 |
|---------------------------------------|--------------------------|--|---|------------------|------------------|
| Configuration | | | | | |
| Capacity (VA / Watts) | | 1000 VA / 1000 W | 1500 VA / 1500 W | 2000 VA / 2000 W | 3000 VA / 3000 W |
| Form | | Rack and Tower Type | | | |
| Phase | | Single Phase | | | |
| Energy Saving | | Yes - ECO Mode Efficiency >94% | | | |
| Input | | | | | |
| Voltage | | 208 - 300 Vac | | | |
| Input Voltage Range | | 120 - 300 VAC, < 25% Load 160 - 300 VAC, < 75% Load | 140 - 300 VAC, < 50% Load 180 - 300 VAC, < 100% Load | | |
| Input Frequency Range | | 50 / 60 Hz (Auto Sensing) | | | |
| Input Power Factor | | >0.98 | | | |
| Cold Start | | Yes | | | |
| Output | | | | | |
| Rated Power Factor | | 1.0 | | | |
| Waveform | | Pure Sine Wave | | | |
| Voltage | | 200 / 208 / 220 / 230 / 240 Vac ± 2% | | | |
| Frequency | | 50 / 60 Hz ±0.25 Hz | | | |
| Transfer Time | | 0 ms | | | |
| Harmonic Distortion | | ≤ 2.5% THD at Linear Load | | | |
| Crest Factor | | 3 : 1 | | | |
| Load Segment | | Yes | | | |
| EPO Function | | Yes | | | |
| Protection | | | | | |
| Overload | Line Mode | 110% - 124% for 10 minutes / 125% - 149% for 2 minutes 150% - 199% for 10 seconds / >200% for 240 milliseconds | | | |
| | Battery Mode | 105% - 110% for 10 seconds / 110% - 119% for 3 seconds 120% - 150% for 1.5 seconds / >150% for 240 milliseconds | | | |
| Surge Protection | | IEC 61000-4-5 Level 3 | | | |
| Bypass | | Internal Bypass (Automatic and Manual) | | | |
| Short Circuit Protection | | UPS Output Cut Off Immediately | | | |
| Battery | | | | | |
| Type & Quantity | | 12V 7Ah x3 | 12V 9Ah x3 | 12V 7Ah x6 | 12V 9Ah x6 |
| Internal Batt. | | Yes | Yes | Yes | Yes |
| Sealed, Maintenance Free | | Yes | | | |
| Typical Recharge Time | | 3 hr to 90% | | | |
| External Battery Module | | Option | | | |
| External Battery Connector | | Option | | | |
| Management & Communication | | | | | |
| LCD Control Panel | | Yes | | | |
| Communication Port | | RS 232, USB B type | | | |
| SNMP Slot | | Option | | | |
| Audible Alarms | | Yes | | | |
| Physical | | | | | |
| Power Module | Dimensions (WxDxH) (mm) | 428 x 435 x 84 | | 428 x 645 x 84 | |
| | Weight (kgs) | 17 | 18.7 | 30.6 | 32.7 |
| | Shipping Dimensions (mm) | 546 x 552 x 206 | | 550 x 750 x 220 | |
| | Shipping Weight (kgs) | 19.8 | 21.5 | 34.4 | 36.5 |
| Batt. Module | Dimensions (WxDxH) (mm) | 428 x 435 x 84 | | 428 x 645 x 84 | |
| | Weight (kgs) | 21.3 | | 39.7 | |
| | Shipping Dimensions (mm) | 546 x 552 x 206 | | 500 x 750 x 220 | |
| | Shipping Weight (kgs) | 24.1 | | 42.9 | |

For all model: * While 200V, 208V output, capacity will be derated to 90%. ** Specifications are subject to change without further notice. ** Specifications are for reference; actual information based on the real product.

20250428
661-NXT1-000-00R-R01