LIA 0608HXCF M
LIA 0911HXCF M
LIA 1316HXCF
LIA 1316HXCF M



LIA 0911HXCF M
LIA 1316HXCF (M)

LIA 0608HXCF M



Installation and Operating Instruction

Split air-to-water heat
pump with Hydrobox

Table of contents

1	Safety notes	EN-3
1.1	Symbols and markings.....	EN-3
1.2	Safety notes for the use of the refrigerant R32.....	EN-3
1.3	General safety notes.....	EN-3
1.4	Intended use.....	EN-3
1.5	Legal regulations and directives.....	EN-4
2	Purpose	EN-4
2.1	Area of application.....	EN-4
2.2	General properties.....	EN-4
3	Scope of supply	EN-5
3.1	Indoor unit.....	EN-5
3.2	Heat pump manager.....	EN-5
3.3	Outdoor unit.....	EN-5
4	Transport and storage	EN-6
4.1	Remove outdoor unit transport protection (depending on device).....	EN-6
4.2	Remove indoor unit transport protection.....	EN-6
5	Installation	EN-7
5.1	Indoor unit.....	EN-7
5.2	Outdoor unit.....	EN-7
5.3	Heat pump installation conditions:.....	EN-9
5.4	Installation in coastal areas.....	EN-11
5.5	Precautions in winter and in seasonal winds.....	EN-11
6	Assembly indoor unit	EN-12
6.1	General.....	EN-12
6.2	Opening indoor unit.....	EN-12
6.3	Indoor unit fixing.....	EN-12
6.4	Connection on heating side.....	EN-13
6.5	Water Quality in Heating Systems.....	EN-13
7	Connecting the pipework and cables to the outdoor unit	EN-15
7.1	Refrigerant pipes.....	EN-15
7.2	Electrical connections.....	EN-18
7.3	Final work.....	EN-20
7.4	Leak test and evacuation.....	EN-20
8	Commissioning	EN-22
8.1	General.....	EN-22
8.2	Preparation.....	EN-22
8.3	Commissioning procedure.....	EN-23
9	Test points, maintenance and troubleshooting	EN-24
9.1	Checklist prior to commissioning.....	EN-24
9.2	Maintenance.....	EN-25
9.3	Troubleshooting.....	EN-26
9.4	Characteristic curve temperature sensor outdoor unit.....	EN-27
9.5	Characteristic curve temperature sensor indoor unit.....	EN-28
10	Cleaning / maintenance	EN-29
10.1	Care.....	EN-29
10.2	Cleaning the heating system.....	EN-29
11	Faults / troubleshooting	EN-29
12	Decommissioning / disposal	EN-29
13	Device information	EN-30
14	Performance values	EN-34
14.1	Performance values, heating LIA 0608HXCF M.....	EN-34

14.2 Performance values, heating LIA 0911HXCF M	EN-35
14.3 Performance values, heating LIA 1316HXCF (M).....	EN-36
14.4 Performance values, cooling LIA 0608HXCF M	EN-37
14.5 Performance values, cooling LIA 0911HXCF M	EN-38
14.6 Performance values, cooling LIA 1316HXCF (M).....	EN-39
15 Product information as per Regulation (EU) No 813/2013, Annex II, Table 2	EN-40
16 Dimension drawings	EN-44
16.1 Dimension drawing outdoor unit LIA 0608HXCF M	EN-44
16.2 Dimension drawing outdoor unit LIA 0911HXCF M / LIA 1316HXCF M / LIA 1316HXCF	EN-45
16.3 Foundation plan LIA 0608HXCF M	EN-46
16.4 Foundation plan LIA 0911HWCF M / LIA 1316HXCF M / LIA 1316HXCF	EN-46
16.5 Dimension drawing indoor unit.....	EN-47
17 Diagrams	EN-48
17.1 Operating limits diagram heating	EN-48
17.2 Operating limits diagram cooling	EN-49
18 Circuit diagrams	EN-50
18.1 Circuit diagram LIA 0608HXCF M / LIA 0911HXCF M	EN-50
18.2 Circuit diagram LIA 1316HXCF M 1-phase.....	EN-51
18.3 Circuit diagram LIA 1316HXCF 3-phase.....	EN-52
18.4 Legend.....	EN-53
19 Hydraulic integration diagrams	EN-55
19.1 Mono energy system with one heating circuit.....	EN-55
19.2 Mono energy system with one heating circuit and domestic hot water preparation.....	EN-56
19.3 Legend.....	EN-57
20 Declaration of conformity	EN-58

1 Safety notes

1.1 Symbols and markings

Particularly important information in these instructions is marked with CAUTION! and NOTE.

⚠ CAUTION!

Immediate danger to life or danger of severe personal injury or significant damage to property.

i NOTE

Risk of damage to property or minor personal injury or important information with no further risk of personal injury or damage to property.

1.2 Safety notes for the use of the refrigerant R32

⚠ CAUTION!

The air-to-water heat pump contains R32. The refrigerant is odourless and flammable

⚠ CAUTION!

Contact of refrigerant with hot surfaces, sparks, naked flames, heat or other ignition sources (e.g. electric radiators) must be avoided.

⚠ CAUTION!

Gas/vapours are heavier than air. They can accumulate in enclosed spaces, especially on the floor or in lower-lying areas.

⚠ CAUTION!

In the event of refrigerant leakage, adequate ventilation must be provided and the area must be cleared immediately thereafter. If ventilation is not possible, leave the area immediately.

⚠ CAUTION!

Thermal decomposition of the gas may produce toxic substances.

⚠ CAUTION!

Contact with liquid refrigerant can cause cold burns/frostbite.

⚠ CAUTION!

At low concentrations, symptoms may include dizziness, headache, nausea, and impaired coordination. There is a risk of suffocation at higher concentrations.

⚠ CAUTION!

The refrigerant must not be released into the atmosphere.

⚠ CAUTION!

Only components, tools and consumables approved for R32 refrigerant may be used for the heat pump listed here.

1.3 General safety notes

⚠ CAUTION!

Work on the heat pump must only be performed by authorised and qualified specialist personnel.

⚠ CAUTION!

The responsibility for heat pump installation lies with the specialist system construction company. During the installation, local requirements such as building regulations, the static load of the building, and wind exposure must be accounted for.

⚠ CAUTION!

For the heat pump to work properly, perform installation, maintenance and repair according to the installation instructions. Improper handling can lead to damage to property and injuries.

⚠ CAUTION!

Refrain from forcibly opening the device or burning it.

⚠ CAUTION!

All work must be carried out in compliance with national regulations, legal provisions and these installation instructions.

⚠ CAUTION!

Do not store or use any flammable or combustible substances near the device.

⚠ CAUTION!

Improper installation or attachment of the device or accessories can result in electric shock, short circuit, leakage, fire and other damage.

⚠ CAUTION!

The device's installation site must be sufficiently large and well ventilated (see cap. 5.3.4).

⚠ CAUTION!

Do not pierce, puncture or crush parts of the refrigerant or water circuit or electric wires.

⚠ CAUTION!

For repair work, only use tools and aids that are approved for use with R32.

⚠ CAUTION!

The air-to-water heat pump must NOT be installed in areas where corrosive gases such as acids or alkaline gases can occur.

1.4 Intended use

This device is only intended for use as specified by the manufacturer. Any other use beyond that intended by the manufacturer is prohibited. This requires the user to abide by the relevant project planning documents. Please refrain from tampering with or altering the device.

1.5 Legal regulations and directives

This heat pump is designed for use in a domestic environment according to Article 1, Paragraph 2 k) of EU directive 2006/42/EC (Machinery Directive) and is thus subject to the requirements of EU directive 2014/35/EU (low-voltage directive). It is thus also intended for use by non-professionals for heating shops, offices and other similar working environments, agricultural establishments and hotels, guest houses and other residential buildings.

The construction and design comply with all relevant EC directives and DIN/VDE regulations (see CE declaration of conformity).

When connecting to the power supply, the relevant VDE, EN and IEC standards must be observed. Any further connection requirements stipulated by local utility companies must also be observed.

When connecting the heating system, all applicable regulations must also be adhered to. Furthermore, the regulations applicable to the local drinking water supply must be observed when connecting to the domestic hot water preparation.

This unit can be used by children aged 8 and over and by persons with limited physical, sensory or mental aptitude or lack of experience and/or knowledge, providing they are supervised or have been instructed in safe use of the unit and understand the associated potential dangers.

Children must not play with the unit. Cleaning and user maintenance must not be carried out by children without supervision.

⚠ CAUTION!

When operating or maintaining a heat pump, the legal requirements of the country where the heat pump is operated apply. Depending on the refrigerant fill quantity, the heat pump must be inspected for leaks at regular intervals by a certified technician, and these inspections must be recorded.

2 Purpose

2.1 Area of application

The indoor unit constitutes the interface between a reversible heat pump and the distribution system in the building. The indoor unit contains all hydraulic components required between heat generation and heat distribution with an unmixed heating circuit.

Observe the operating limits according to the device information.

The circulating pump(s) must be controlled using the heat pump manager.

If function-relevant or safety-relevant pump functions, such as integration of the heat pump into the building management system, are not supported, then this can result in loss of warranty and cause a write-off of the heat pump.

The circulating pump(s) and the heat pump controller must always be ready for operation.

The specifications in the technical documents must be followed, particularly limit values for the minimum and – if available – maximum warm/cold water volume flow.

2.2 General properties

- Minimal installation effort due to ready-to-use integrated components
- Ready for use, contains all essential components by way of pumps, flow rate sensors, safety technology and heat pump manager
- The infinitely adjustable operation of the circulating pump permits adjustment of the output according to need.
- Switchable pipe heater (2/4/6 kW) for supplementary heating and domestic hot water reheating

3 Scope of supply

3.1 Indoor unit

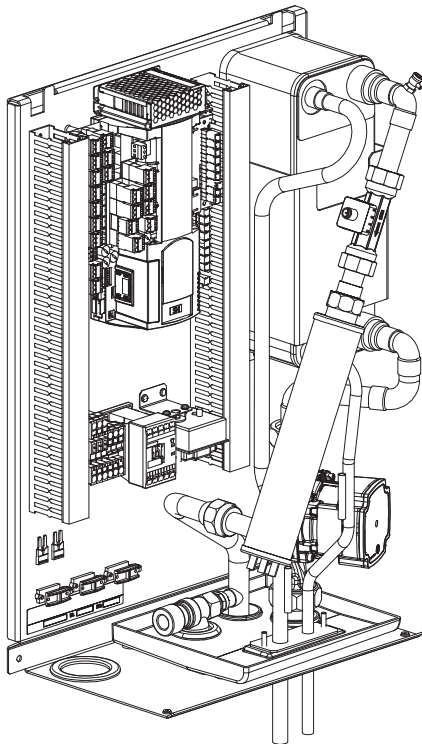

Hydraulic components

- Unmixed heating circuit including controlled circulating pump
- 2nd heat generator, electrical pipe heater, heat output 2 / 4 / 6 kW, secured via safety temperature limiter
- Flow rate sensor

Safety equipment:

- Safety valve, start-to-leak pressure 2.5 bar

Refrigerating equipment

- Heat exchanger refrigerant / heating water
- Connections for split line

Electrical components

- Heat pump manager with connection boards
- Supply connection terminals and contactor, pipe heater

i NOTE

External sensor is included with the outdoor unit as standard. Connection of an external sensor is possible Chapt. 8.5.2 on P. 16.

3.2 Heat pump manager

The integrated heat pump manager is a convenient electronic regulating and control device. It controls and monitors the entire heating system based on the outside temperature, as well as domestic hot water preparation and safety systems.

The enclosed operating instructions describe the function and use of the heat pump manager.

3.3 Outdoor unit

3.3.1 6 kW outdoor unit

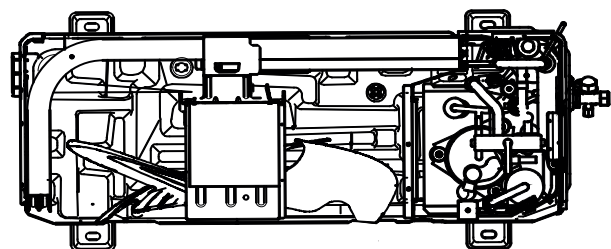
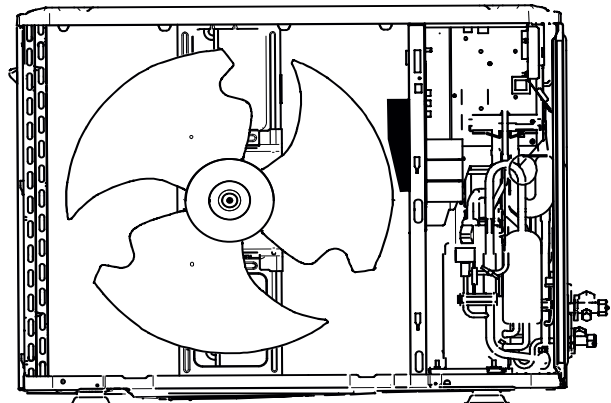

3.3.2 10 kW / 14 kW outdoor unit

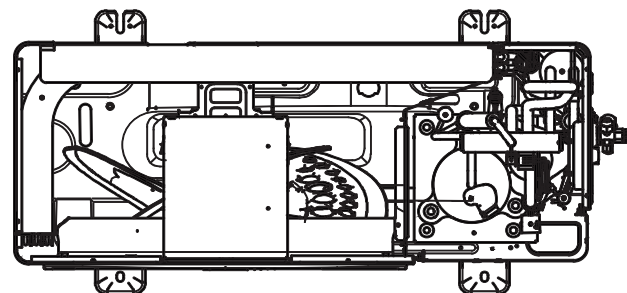
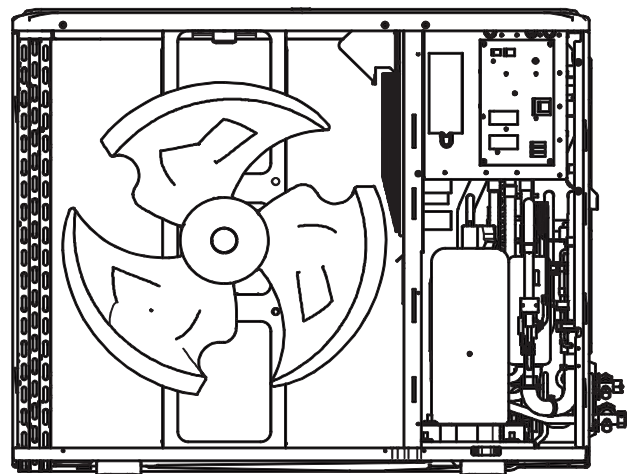

4 Transport and storage

During transport and storage, the unit must be kept in a dry place and must not be exposed to temperatures below freezing.

When storing the unit, care should be taken to ensure that no other gases, liquids or solids can enter the unit. The connections of the unit should remain closed until the unit is finally installed. Furthermore, care must be taken to ensure that no damage can occur to the unit or individual components during the transport and storage of the unit. Please make sure that the unit is not stacked (no load from above on the unit) or crushed.

When storing the unit, make sure that it is stored in a room with a sufficiently large space (especially when storing in basements, garages, conservatories, etc.).

⚠ CAUTION!

Refer to the product packaging labels for storage and transport information.

⚠ CAUTION!

The unit must be stored in a well ventilated room where there is no continuously present ignition source (example: naked flames, gas-powered household appliance, electrically-powered heating device, workshops).

⚠ CAUTION!

The unit must be stored in a well ventilated room where the room size corresponds to the intended room area for operation. (see cap. 5.3.4)



4.1 Remove outdoor unit transport protection (depending on device)

After transportation, the transport fastening in the device is to be removed from the base.

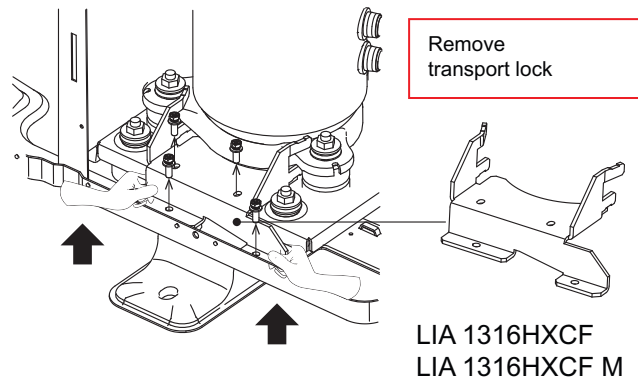

⚠ CAUTION!

Please ensure that the transport fastening has been removed.

It causes unusual vibrations and noises at the heat pump if it is operated with the transport fastening for the compressor installed.

4.2 Remove indoor unit transport protection

The transport protection on the cover must be removed before installation (see Fig. 4.1 on page 6).

Open the cover to install the indoor unit (see Cap. 6.2 on page 12).

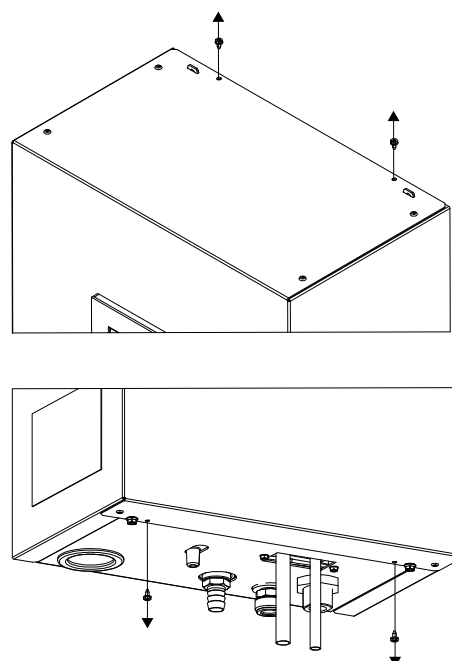

Fig. 4.1:

5 Installation

5.1 Indoor unit

5.1.1 General

The unit should always be installed indoors on a level, smooth wall. Maintenance work can be carried out easily from the operator side (a larger minimum distance at the side is required; assembly clearance of 5 cm must be adhered to). This can be ensured by maintaining a distance of approx. 1 m at the front. The indoor unit should be mounted at a height of approx. 1.20 m. Installation must be carried out in a frost-proof room and using short pipelines.

i NOTE

Setup and installation must be performed by an authorised specialist company.

⚠ CAUTION!

The unit must not be mounted or operated near a naked flame, gas-powered devices, electric heaters or any other comparable source of ignition.

⚠ CAUTION!

The unit must not be installed in a room that is also used as a workplace or workshop (risk of ignition due to flying sparks).

⚠ CAUTION!

When installing the unit, make sure that no ventilation openings are blocked.

i NOTE

The heat pump is not intended for use above 2000 metres (mean sea level).

5.2 Outdoor unit

- It is advisable to install the outdoor unit close to a wall, on a foundation separate from the building with a minimum clearance of 0.3 m on the intake side (Fig. 5.1 + Fig. 5.2).
- If a canopy is mounted to protect from direct sunlight, rain or snow it must not impede the heat exchange of the unit.
- In the case of a free-standing installation, the foundation is to be connected on the intake side, flush with the unit. This will prevent snow from building up between the foundation and the evaporator.
- The minimum clearances (Fig. 5.1) indicated must be adhered to.
- When selecting an installation location, it should be ensured where possible that persons are not going to be inconvenienced by the circulation of warm/cold air or by noise emissions.
- The condensate tray offers various options for condensate draining. In warmer regions, the condensate can drain from the device freely. In regions with longer periods of frost, controlled condensate draining is required.



Abb. 5.1



Abb. 5.2

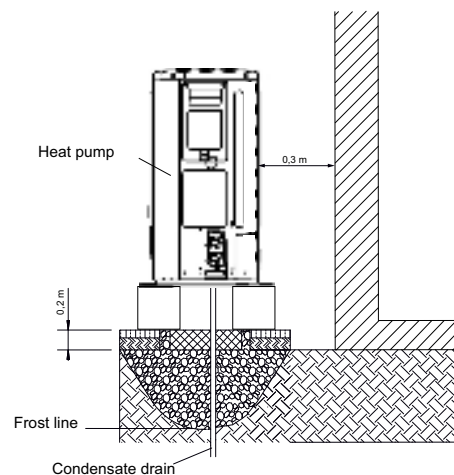

Abb. 5.3

If the unit is installed on a wall bracket, special attention must be paid to separate any sound to the building.

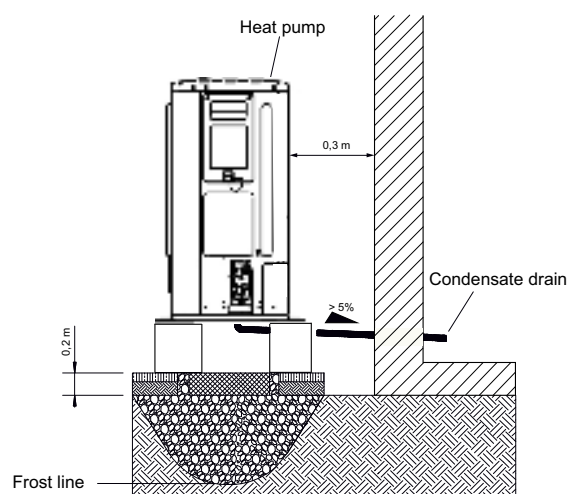
If the wall bracket installation option is selected, the following points must be observed:

- Fit rubber buffers
- Take the weight of the outdoor unit into account
- Ensure that the wall bracket is no higher than 1 m above the ground
- Ensure that minimum clearances are adhered to

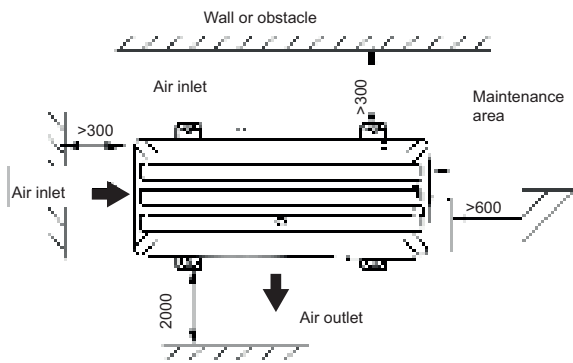

Abb. 5.4

When installing several outdoor units next to each other, the specified distances must be observed. Furthermore, if several outdoor units are installed, it must be ensured that the air inlets and outlets do not affect any of the other units.

i NOTE

Structural influences must be observed for installation close to walls. No windows or doors should be present in the area surrounding the air outlet of the fan.

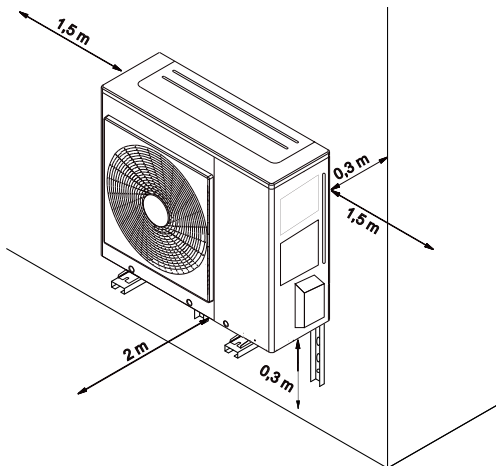
i NOTE

Installation in a hollow or in an inner courtyard is not permitted because cooled air collects at ground level and is drawn in again by the heat pump during extended periods of operation.

⚠ CAUTION!

Incorrect installation, maintenance or repair may increase the risk of cracks in the installed piping, resulting in property damage.

⚠ CAUTION!

Improper installation of the unit may restrict operation of the system.

5.2.1 Wall opening, split lines and electric wires

Please proceed as follows when laying split lines and electric wires:

- Drill a 70 mm opening for the pipework using a core drill.
- The opening for the pipework should be slightly inclined towards the outdoor unit, so that no rainwater can penetrate the building.

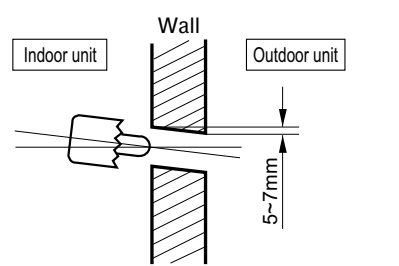

During installation work, please ensure that connection points are easily accessible for maintenance and repair purposes.

⚠ CAUTION!

Care must be taken to ensure that the connections and lines are not subjected to any mechanical loads.

⚠ CAUTION!

Connection lines must not exhibit any mechanical damage.

5.2.2 Wall opening for condensate drain

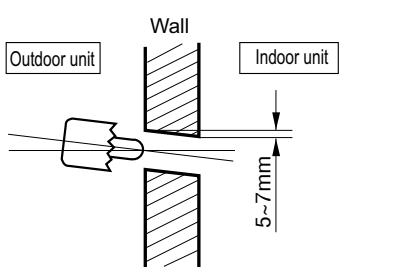

For the safe drainage of the condensate, the condensate drain must be positioned in such a way that no frost build-up can occur. The frost line can vary according to the climatic region. The regulations of the countries in question must be observed.

When laying the condensate connection, pay attention to the slope that must be maintained.

5.3 Heat pump installation conditions:

The refrigerating system described in this manual is filled with R32. The refrigerant R32 is a colourless, odourless and flammable gas.

Due to it having a higher density than air, R32 can accumulate in lower-lying areas without adequate ventilation. At low concentrations, symptoms may include dizziness, headache, nausea, and impaired coordination. There is a risk of suffocation at higher concentrations.

In order to ensure safe operation and, above all, to prevent personal injury in the event of a leakage, certain criteria apply to the installation site which must be met in order to minimise possible hazards to persons, property and the environment.

5.3.1 General installation conditions:

Install the heat pump in rooms with sufficient air circulation.

Do not block off any ventilation openings when installing the heat pump.

Do not store or use flammable or combustible substances near the heat pump.

The installation site of the heat pump must not be used as a workplace or workshop.

Do not expose the device to high temperatures, flames, sparks or sources of ignition (e.g. electric radiator).

The device must not be installed or operated near a naked flame, gas-powered devices, electric heaters or any other comparable source of ignition.

During installation, ensure that the system is easily accessible for maintenance and repair purposes.

The minimum amount of space for the installation room must be observed depending on the filling quantity of the system (see cap. 5.3.4 on page 10 Minimum room volume).

⚠ CAUTION!

The minimum amount of space for the room must also be observed when storing the heat pump.

5.3.2 Minimum installation space requirements:

The heat pump described in this manual is a refrigerant-filled device that must be installed in accordance with the requirements of EN 378-1_4:2016. With regard to the standard, it must be ensured that the installation room is of a sufficient size such that the limit values for toxicity and flammability are not exceeded indoors.

When considering the minimum installation space for the room, the filling quantity of the system is decisive. Please note that extending the connection lines of the device can result in a changed filling quantity of the system. Therefore, check whether the installation room is suitable, even when taking a potentially higher refrigerant fill quantity into account. The installation room is defined as any space that contains refrigerant-containing parts (indoor unit, outdoor unit and refrigerant pipes) or into which refrigerant could be released. Multiple rooms that have suitable openings (that cannot be closed) between the individual rooms or which are connected to a common ventilation supply, return or exhaust system that does not contain the evaporator or condenser shall be treated as a single room.

As a general rule, care should be taken during installation work to keep refrigerant lines to a necessary minimum.

To check the necessary conditions for installation, proceed as follows:

Determination of the refrigerant fill quantity:

Please note that altering the refrigerant fill quantity may be necessary due to the extension of the connection pipes.

Use the table below in Cap. 5.3.4 on page 10 Minimum room volume to check whether the installation conditions are sufficient for the operation of the heat pump.

5.3.3 Toxicity and flammability limit values:

If the refrigerant fill quantity is below 1.842 kg, the toxicity limit value is the determining factor for the installation conditions.

The fill quantity is the toxicity limit value x room volume.

The toxicity limit value corresponds to the ATEL/ODL values or the practical limit value, whichever is higher.

R32 ATEL/ODL = 0.30

R32 practical limit = 0.061

Concentration limit (toxicity):

R32 = 1 x (0.3) = 0.3 kg per 1 m³ volume

i NOTE

The installer must ensure a room volume of 1 m³ per 0.3 kg of R32 refrigerant.

LIA 0608 (1.5 kg R32) = minimum room volume 5 m³

LIA 0911 (1.65 kg R32) = minimum room volume 5.50 m³

LIA 1316 (1.84 kg R32) = minimum room volume 6.1 m³

If the refrigerant fill quantity of the system exceeds 1.842 kg, the flammability limit value is the determining factor for the in-

stallation conditions. It should be noted here that, in contrast to the toxicity limit value, this relates to the room area.

Calculation of the maximum permissible refrigerant fill quantity for a given area:

$$M_{\max} = 2,5 \times \text{LFL}^{\frac{5}{4}} \times h_0 \times A^{\frac{1}{2}}$$

Calculation of the minimum area for a given refrigerant fill quantity:

$$A_{\min} = \frac{m^2}{(2,5 \times \text{LFL}^{\frac{5}{4}} \times h_0)^2}$$

M_{max} is the maximum permissible fill quantity in a room in kg.

m is the refrigerant fill quantity in the system in kg.

A_{min} is the required minimum room area in m².

LFL the lower flammability limit (LFL) in kg/m³

A is the room area in m².

h₀ is the height factor of the device, according to EN60335-2-40 = 1.2 m

5.3.4 Minimum room volume

Calculated according to EN378-1_4:2016 and EN60335-2-40, the following room sizes are obtained (see table) for the respective pipe length and the resulting fill quantity. Due to the flammability and toxicity of the refrigerant, the following minimum room sizes must be observed.

LIA 0608HXCF M																	
Pipe length	m	≤15	16	17	18	19	20	21	22	23	24	25	26	27	28	29	30
Fill quantity	kg	1.5	1.52	1.54	1.56	1.58	1.6	1.62	1.64	1.66	1.68	1.7	1.72	1.74	1.76	1.78	1.8
Minimum room volume toxicity	m ³	5.00	5.07	5.13	5.20	5.27	5.33	5.40	5.47	5.53	5.60	5.67	5.73	5.80	5.87	5.93	6.00
Minimum room volume flammability	m ³	3.26	3.30	3.34	3.39	3.43	3.47	3.52	3.56	3.60	3.65	3.69	3.74	3.78	3.82	3.87	3.91
Minimum room area flammability	m ²																

LIA 0911HXCF M																	
Pipe length	m	≤15	16	17	18	19	20	21	22	23	24	25	26	27	28	29	30
Fill quantity	kg	1.65	1.688	1.726	1.764	1.802	1.84	1.878	1.916	1.954	1.992	2.03	2.068	2.106	2.144	2.182	2.22
Minimum room volume toxicity	m ³	5.50	5.63	5.75	5.88	6.01	6.13	6.26	6.39	6.51	6.64	6.77	6.89	7.02	7.15	7.27	7.40
Minimum room volume flammability	m ³	3.58	3.67	3.75	3.83	3.91	4.00										
Minimum room area flammability	m ²						7.50	7.81	8.12	8.44	8.77	9.10	9.44	9.78	10.13	10.49	

LIA 1316HXCF (M)																	
Pipe length	m	≤15	16	17	18	19	20	21	22	23	24	25	26	27	28	29	30
Fill quantity	kg	1.84	1.878	1.916	1.954	1.992	2.03	2.068	2.106	2.144	2.182	2.22	2.258	2.296	2.334	2.372	2.41
Minimum room volume toxicity	m ³	6.13	6.26	6.39	6.51	6.64	6.77	6.89	7.02	7.15	7.27	7.40	7.53	7.65	7.78	7.91	8.03
Minimum room volume flammability	m ³	4.00															
Minimum room area flammability	m ²		7.50	7.81	8.12	8.44	8.77	9.10	9.44	9.78	10.13	10.49	10.85	11.22	11.59	11.97	12.36

The internal unit of the heat pump system is designed in such a way that all the refrigeration circuit components are located in the right side of the indoor unit, at a lower edge of 1.2 metres. When placing the indoor unit, it must be ensured that the solder connections are located outside the closed Hydrobox and they are to be mounted at 1.2 metres. The positioning of the refrigeration circuit components defines the height factor h₀ of the unit according to EN 60335-2-40. This is needed to calculate the minimum area.

5.4 Installation in coastal areas

If the unit is installed close to the sea, the high salt concentration can lead to increased corrosion. If necessary, the maintenance intervals must be adapted to the local conditions. The responsibility for heat pump installation lies with the specialist system construction company. Local requirements such as building regulations, static load of the building, wind exposure etc. must be taken into account.

i NOTE

If the outdoor unit is installed in a coastal area, direct sea wind must be avoided.

Case 1: If the outdoor unit is installed in a coastal area, direct sea wind should be avoided. Install the outdoor unit in the opposite direction to the sea wind.

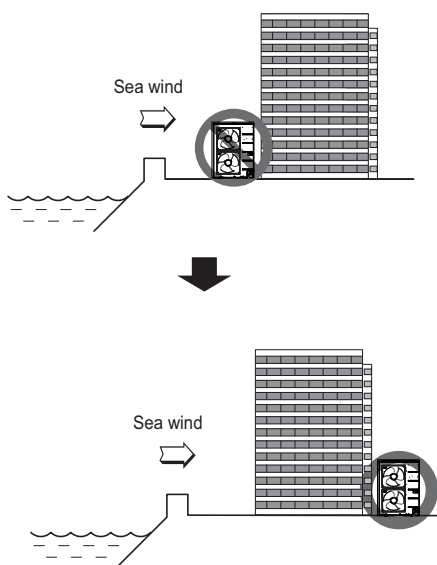

Case 2: If the outdoor unit is installed in the direction of the sea wind, set up a wind guard to catch the sea wind.

- The wind guard must be robust enough to catch the sea wind (e.g. made from concrete).
- The height and width of the wind guard must correspond to at least 150% of the outdoor unit.
- A distance of at least 700 mm from the outdoor unit must be maintained to guarantee sufficient air flow.

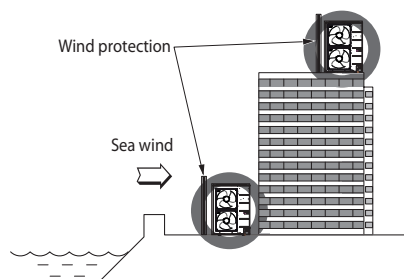

i NOTE

Dust or salt soiling on the heat exchanger should be regularly cleaned (at least once a year) with running water.

i NOTE

The use of heat pumps is safe from a distance of 12 km from the sea with a maximum salt content of 3.5%

If the heat pump is installed on the rear side of a building facing away from the sea, the required minimum distance is halved

For waters with low salinity, the following calculation formula may be used:

$$\text{Minimum distance} = \frac{12 \text{ km} \times \text{salinity in \%}}{3,5 \%}$$

The minimum distance if installed on the Baltic Sea with a salt content of 1.5%, for example, would be 5.14 km. This could be reduced to 2.5 km if the heat pump was on the rear of the building facing away from the sea.

⚠ CAUTION!

Incorrect installation, maintenance or repair can result in damage to property and personal injury.

5.5 Precautions in winter and in seasonal winds

- In snowy areas or extremely cold locations, adequate protective measures must be taken to guarantee that the unit continues functioning correctly.
- Install the outdoor unit such that snow cannot fall directly on the unit. If snow collects on the air inlet and freezes, malfunctions could occur.
- When installing the outdoor unit in areas where there is a lot of snowfall, ensure the unit is installed at least as high as the level of an average snowfall (average annual snowfall).
- If more than 100 mm of snow collects on the outdoor unit, the snow must be removed prior to operation.

i NOTE

The intake and outlet opening of the outdoor unit should not be positioned against the wind if possible.

6 Assembly indoor unit

6.1 General

The following connections need to be established on the indoor unit (see "Dimension drawing indoor unit" on page 47.)

- Flow / return of the heating system
- Safety valve outflow
- Power supply
- Voltage supply
- Split refrigerant pipe
- Condensate drain
- Expansion vessel connection (optional)

i NOTE

Setup and installation must be performed by an authorised specialist company.

6.2 Opening indoor unit

The cover must be removed to allow access to the inside of the device.

⚠ CAUTION!

Before opening the device, ensure that all electric circuits are disconnected from the power supply.

The two screws on the bottom must be loosened for this. Then swing out the bottom cover to the front and remove upwards.

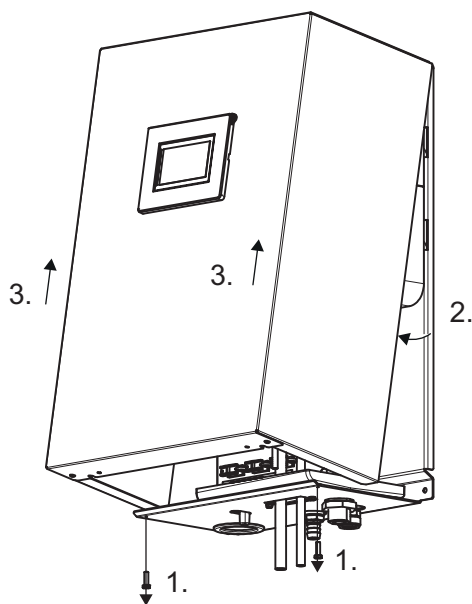

i NOTE

When removing the unit cover, it must be taken into account that the length of the connecting cables between the control panel in the unit cover and the controller on the contact plate as well as the earthing cable is only 1.5 m. If the device cover can only be placed further away than this when it has been removed, the plug connection on the controller or on the control panel must first be disconnected.

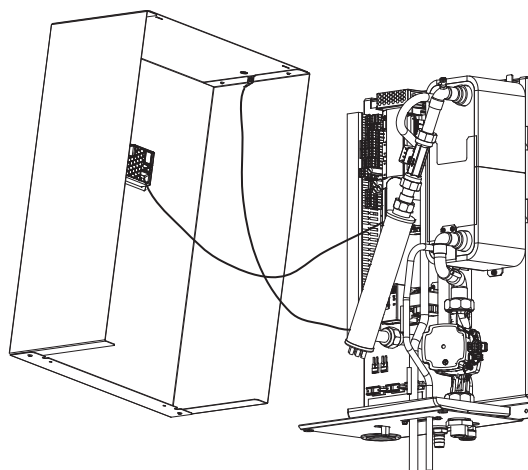

After removing the cover, the electronics area is freely accessible.

The contact plate contains the power supply connection terminals, heating contactors and the heat pump manager.

⚠ CAUTION!

Before switching the electric circuits back on, ensure that the device has been sealed and live parts cannot be touched.

6.3 Indoor unit fixing

The indoor unit is attached to the wall with the screws and dowels (8 mm) included in the scope of supply. The following procedure should be used:

- Mount the dowels for the top fastening eyelets.
- Screw the screw into the dowel so that the indoor unit can be mounted.
- Mount the indoor unit by the upper fastening eyelets.
- Mark the position of the bottom drill holes. Unhook the indoor unit again.
- Mount the dowels for the bottom drill holes.
- Remount the indoor unit at the top and tighten the screws.

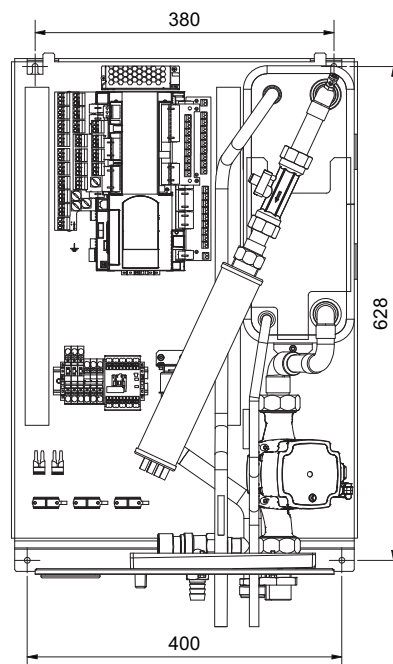

6.4 Connection on heating side

The heating system connections on the indoor unit have a 1" flat sealing external thread. A spanner must be used to firmly grip the transitions when making the connections.

There is a hose sleeve on the safety valve for on-site connection of a plastic hose. This should be fed into a siphon or outflow.

Before connecting the heating water system to the heat pump, the heating system must be flushed to remove any impurities, residue from sealants, etc.

CAUTION!

Any accumulation of deposits in the liquefier may cause the heat pump to completely break down.

Once the heat pump has been connected to the heating system, it must be filled, purged and pressure-tested.

NOTE

Pump units with check valves maintain the specified flow directions. If there is incorrect distribution or breaking off of the volume flow, these units (and the check valves in particular) must be checked! The use of check valves are mandatory in the event of several heating circuits or parallel connections for heat pumps in order to avoid incorrect distribution.

6.5 Water Quality in Heating Systems

6.5.1 Scale Formation

Scale formation in heating systems cannot be avoided, but in systems with flow temperatures below 60 °C the problem is so small that it is negligible. With high-temperature heat pumps and in particular with bivalent systems in the higher performance range (heat pump + boiler combination), flow temperatures of 60 °C and more can be achieved. One preferred method for preventing scale formation is softening because this permanently removes alkaline earths (calcium and magnesium ions) from the heating system.

The following values for water quality in heating water and cold water must be observed and checked during an on-site check:

- Degree of hardness
- Conductivity
- pH value
- Filterable materials

The following (limit) values must absolutely be observed:

- Maximum degree of hardness in filling water and supplementary water 11 dGH.
- The conductivity in demineralised water (DM water) (low-salt) may not be greater than 100 µS/cm.
- The conductivity in partially demineralised water (saline) may not be greater than 500 µS/cm.
- The pH value must be between 8.2 and 9.
- The limit value for filterable materials in heating water is < 30 mg/l

If necessary, for example in bivalent systems, the specifications listed in the table below must also be observed, or the precise guidelines for filling water and supplementary water and the total hardness must be taken from the table in accordance with VDI 2035 – Sheet 1.

NOTE

The specific volumes of a heating system must be determined before filling the system.

The saturation index SI is used to determine whether water has a tendency towards lime dissolution or lime separation. This shows whether the pH value corresponds to a neutral pH point or by how much it undershoots it due to excess acid or by how much it exceeds it due to carbonic acid deficit. At a saturation index below 0, the water is aggressive and will tend towards corrosion. At a saturation index above 0, the water is calcareous.

The saturation index SI should be between $-0.2 < 0 < 0.2$

Filling and supplementary water as well as heating water, depending on heat output			
Overall heat output in kW	Total alkaline earths in mol/m ³ (Total hardness in dGH)		
	≤ 20	> 20 to ≤ 50	> 50
	Specific system volume in l/kW Heat output ¹		
≤ 50 specific water content heat generator > 0.3 k per kW ²	none	≤ 3.0 (16.8)	< 0.05 (0.3)
≤ 50 specific water content heat generator > 0.3 k per kW ² (e.g. circulating water heaters) and systems with electric heating elements	≤ 3.0 (16.8)	≤ 1.5 (8.4)	
> 50 kW to ≤ 200 kW	≤ 2.0 (11.2)	≤ 1.0 (5.6)	
> 200 kW to ≤ 600 kW	≤ 1.5 (8.4)	< 0.05 (0.3)	
> 600 kW	< 0.05 (0.3)	< 0.05 (0.3)	
Heating water, depending on heating output			
Operating mode	Electrical conductivity in µS/cm		
Low-salt ³	> 10 to ≤ 100		
Containing salt	> 100 to ≤ 1500		
	Appearance		
	clear, free from sedimentary substances		

1. For the purpose of calculating the specific system volume, the smallest individual heat output is to be used for systems with several heat generators.
2. In systems with several heat generators with different specific water contents, the smallest specific water content is decisive.
3. Full softening is recommended for systems with aluminium alloys.

Fig. 6.1: Guideline values for filling and supplementary in accordance with VDI 2035

CAUTION!

When using demineralised water, ensure that the minimum permissible pH value of 8.2 is not undershot. Failure to comply with this value can result in the heat pump being destroyed.

6.5.2 Corrosion

The VDI 2035 recommends the use of partially demineralised water or demineralised water in systems with larger-than-average specific system volumes of 50 l/kW.

These measures (e.g. pH stabilizers) are implemented to set the pH value of the heating water to minimise the risk of corrosion in the heat pump and in the heating system.

Irrespective of the legal requirements, the following limit values in the heating water used for various substances must not be undershot or exceeded. This is to ensure safe operation of the heat pump. A water analysis must be carried out before commissioning the system. If the water analysis produces a "-" for a maximum of one indicator or a "o" for a maximum of two indicators, the analysis must be classed as negative.

Evaluation characteristic	Concentration range (mg/l or ppm)	Stainless steel	Copper
Bicarbonate (HCO ₃ ⁻)	< 70	+	o
	70 - 300	+	+
	> 300	+	o
Sulphate (SO ₄ ²⁻)	< 70	+	+
	70 - 300	o	o/-
	> 300	-	-
Hydrogencarbonate/sulphate HCO ₃ ⁻ /SO ₄ ²⁻	> 1.0	+	+
	< 1.0	o	-
Electrical conductivity ¹	< 10 µS/cm	o	o
	10 - 500 µS/cm	+	+
	> 500 µS/cm	o	o
pH value ²	< 6.0	-	-
	6.0 - 8.2	o	o
	8.2 - 9.0	+	+
	> 9.0	o	o
Ammonium (NH ₄ ⁺)	< 2	+	+
	2 - 20	o	o
	> 20	-	-
Chloride ions (Cl ⁻)	< 50	+	+
	50 - 150	o	o
	> 150	-	-
Free chlorine (Cl ₂)	< 0.5	+	+
	0.5 - 5	-	o
	> 5	-	-
Hydrogen sulphide (H ₂ S)	< 0.05	+	+
	> 0.05	+	o/-
Carbon dioxide (CO ₂)	< 5	+	+
	5 - 10	+	o
	> 10	o	-
Nitrate (NO ₃ ⁻)	< 100	+	+
	> 100	o	o
Iron (Fe)	< 0.2	+	+
	> 0.2	o	o
Aluminium (Al)	< 0.2	+	+
	> 0.2	+	o
Manganese (Mn)	< 0.05	+	+
	> 0.05	o	o

Saturation Index	< -0.2	o	o
	-0.2 - 0.1	+	+
	0.1 - 0.2	+	o
	> 0.2	o	o
Filterable materials	< 30	+	+
	> 30	-	-
Total hardness	< 6 °dGH	o/+	o/+
	6 - 11 °dGH	+	+
	> 11 °dGH	-	-
Oxygen (O ₂)	< 0.02	+	+
	< 0.1	+/o	+/o
	> 0.1	-	-
Nitrite (NO ₂ ⁻)	< 0.1	+	+
	> 0.1	-	-
Sulphide (S ²⁻)	< 1.0	+	+
	> 1.0	-	-

1. If the limit values in the VDI 2035 are more restrictive, these apply accordingly.

2. When using demineralised water, ensure that the minimum permissible pH value of 8.2 is not undershot. Failure to comply with this value can result in the heat pump being destroyed.

Fig. 6.2: Limit values for the quality of heating water

Resistance of copper-soldered or welded stainless-steel plate heat exchangers to the substances present in water:

Notes

- "+" = Normally good resistance
- "o" = Corrosion problems may arise, particularly if several factors receive an evaluation of "o"
- "-" = Should not be used

i NOTE

The water quality should be checked again after 4 to 6 weeks, as the quality could change during the first few weeks of operation due to chemical reactions.

i NOTE

It is mandatory to use hydraulically closed systems. It is not permissible to use any open hydraulic systems!

Filling and purging of the system must be carried out on-site.

i NOTE

If the unit is connected to an existing hydraulic water circuit, the hydraulic pipes must be cleaned to remove residues and limescale.

A suitable purging facility must also be installed in the heating circuit on-site.

It is recommended to install a shut-off device in the return before integration into the indoor unit is carried out.

Minimum heating water flow rate

The minimum heating water flow rate through the heat pump must be assured in all operating statuses of the heating system.

⚠ CAUTION!

If the minimum heating water flow rate is undershot, the plate heat exchanger in the refrigeration circuit can freeze, which can lead to total damage of the heat pump.

The nominal flow rate is specified depending on the max. flow temperature in the device information and must be taken into account during planning. With design temperatures below 30 °C in the flow, the design must be based on the max. volume flow with 5 K spread for A7/W35.

The specified nominal flow rate (see “Device information” on page 30.) must be assured in all operating states. A built-in flow rate sensor is used only for switching off the heat pump in the event of an unusual and abrupt drop in the heating water flow rate and not for monitoring and fusing the nominal flow rate.

Frost protection

If the indoor unit is installed where there is a risk of frost, manual drainage must be provided where required. The frost protection function of the heat pump manager is active whenever the heat pump manager and the heat circulating pump are ready for operation. The system must be drained if the heat pump is taken out of service or in the event of a power failure. The hydraulic network should be operated with suitable frost protection if heat pump systems are implemented in buildings where a power failure cannot be detected (e.g. holiday homes).

7 Connecting the pipework and cables to the outdoor unit

This chapter describes the refrigerant pipe connections and the electrical cable connections on the outdoor unit.

7.1 Refrigerant pipes

⚠ CAUTION!

Work on the system must only be performed by authorised and qualified after-sales service technicians.

Certain requirements with regard to pipe length and rise must be complied with when installing refrigerant pipes. Once all requirements have been fulfilled, certain preparations must be made.

Once these are complete, the connecting pipe from the outdoor unit to the indoor unit can be connected.

Make sure that no foreign substances get into the refrigerant lines during installation work. Furthermore, make sure that no oxygen gets into the refrigeration circuit. The connection lines must be evacuated. The installation of piping should be restricted to the minimum possible.

During installation work, please ensure that the connections and lines are not subjected to any mechanical loads. The refrigerant lines must be protected from damage to prevent leakage and the associated escape of refrigerant. All connection points between the outdoor and indoor unit must be easily accessible for maintenance and repair purposes.

After completion of the pipe system, check all pipes for leaks using suitable means and only carry out leakage tightness tests with dry nitrogen. When carrying out the leakage tightness test, never apply more pressure to the system than is specified in the instructions and on the type plates.

⚠ CAUTION!

All installation work for the pipe system must be carried out by specialist personnel.

⚠ CAUTION!

Incorrect installation, maintenance or repair of this device may increase the risk of damage to property or personal injury.

⚠ CAUTION!

Connector surfaces must be checked for cleanliness before assembly and, if necessary, cleaned with the aid of suitable agents.

⚠ CAUTION!

Work on the device must be subject to local and national standards.

⚠ CAUTION!

Always wear adequate personal protective equipment (protective gloves, safety glasses, etc.) when working with refrigerant.

⚠ CAUTION!

Work involving R32 refrigerant must only be carried out by experienced and adequately trained personnel.

⚠ CAUTION!

Only equipment and tools intended for the product, pressure and temperatures may be used for work on the unit.

⚠ CAUTION!

When working on the device, the use of spark-generating machines should be avoided.

7.1.1 Requirements for the pipe length and rise

Model	Pipe size in mm (inch) (Diameter:)		Length A (m)			Rise B (m)		*Additional refrigerant (g/m)
	Gas	Liquid	Normal	Min.	Max.	Normal	Max.	
6 kW	15.9 (5/8")	6.35 (1/4")	15	3	30	0	15	20
10 kW	15.9 (5/8")	9.52 (3/8")	15	3	30	0	15	38
14 kW	15.9 (5/8")	9.52 (3/8")	15	3	30	0	15	38

Additional refrigerant	Model	Total length of the pipe for liquid	
		≤ 15 m	> 15 m
Total additional refrigerant	6 kW	0 g	(A-15) x 20 g
Total additional refrigerant	10 kW	0 g	(A-15) x 38 g
Total additional refrigerant	14 kW	0 g	(A-15) x 38 g

The standard pipe length is 15 m. Up to a length of 15 m, no additional refrigerant filling is required. For pipe lengths over 15 m, the system must be filled with additional refrigerant in accordance with the table.

*Example: When installing the 14 kW model at a distance of 30 m, 570 g refrigerant must be added according to the following calculation: $(30-15) \times 38 \text{ g} = 570 \text{ g}$

i NOTE

For filling with additional refrigerant, see Cap. 5.3 on page 9.

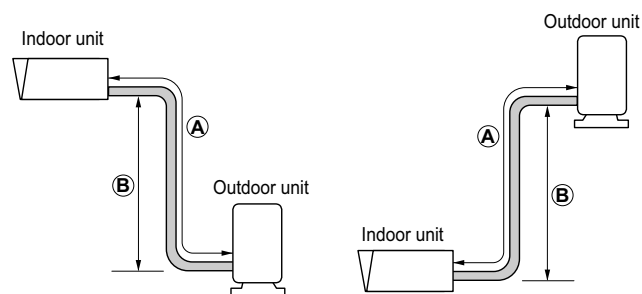

i NOTE

If the indoor unit is mounted 4 m or more metres higher or lower than the outdoor unit, a cooling technology specialist must perform a separate check to ensure that the devices for conveying the oil up and down the pipes have been installed correctly in the split line.

i NOTE

The rated output of the device may vary depending on the split line length.

⚠ CAUTION!

Incorrect filling with refrigerant could lead to faults during operation.

- 1) Production operation (see model name label)
- 2) Installation operation (where possible, attach alongside the maintenance connections for adding or removing refrigerant)
- 3) Total filling (1, + 2,)

⚠ CAUTION!

If the filling quantity changes, document it in an easily visible place (e.g. filling quantity on the type plate). Do not add more than the specified amount of refrigerant to the system.

7.1.2 Preparation for pipework

The preparation of the pipework takes place in five steps. One main cause of refrigerant leaks is incorrect flanging. Flanging must be carried out carefully and according to the following steps.

Step 1: Cutting pipes and cables

- Use the installation kit for pipework or the pipes purchased from your local dealer.
- Measure the distance between the indoor and outdoor unit.
- Cut the pipes slightly longer than the measured distance.

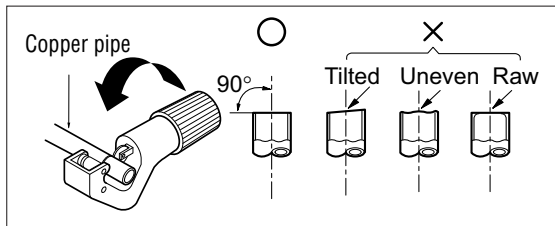

Step 2: Removing burrs

- Remove all burrs from the interface of the pipework.
- Hold the pipe end downwards so that no burrs can fall into the pipe.

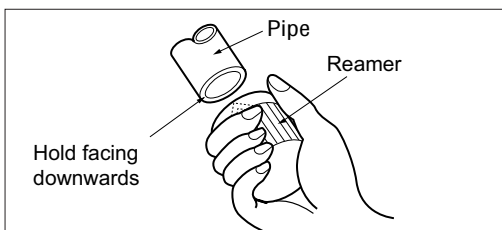

Step 3: Inserting screw nuts

- Remove the screw nuts on the outdoor unit.
- Insert the screw nuts into the deburred pipe.
- No nuts can be inserted into the pipe after flanging.

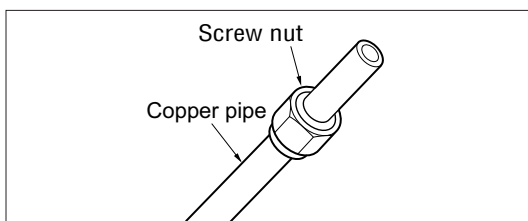

Step 4: Flanging

- Flanging must be carried out as follows with a flanging tool for R32 refrigerant as shown in the figure.

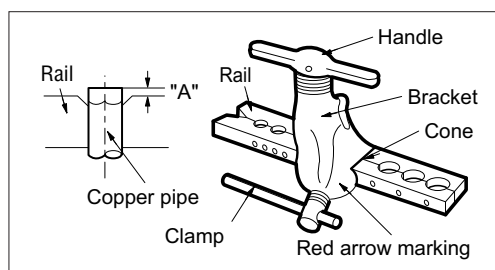

Step 5: Checks

- Compare the flanging with the figure.
- If the flanging is visibly damaged, cut the relevant section off and repeat the flanging.

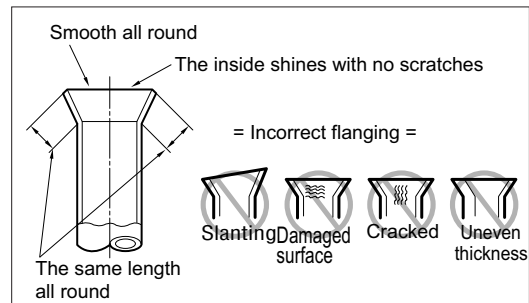

- Alternatively, use the soldering adapters included in the scope of supply of the refrigerant pipe (Sangi soldering adapters).

External diameter of pipe [mm/inch]	Torque [Nm]
6.35 / 1/4	14 - 18
9.52 / 3/8	33 - 42
15.88 / 5/8	63 - 77

7.1.3 Pipe connections on the indoor unit

The pipe connection on the indoor unit takes place in two steps.

Step 1: Preparation

- Align the centre of the pipes so that they interlock.

Step 2: Fastening

- Solder the pipes in place using nitrogen.

7.1.4 Pipe connections on the outdoor unit

The pipe connection on the outdoor unit takes place in steps.

Step 1: Determining the direction in which the pipes are to run

- The pipes are to be aligned to the rear

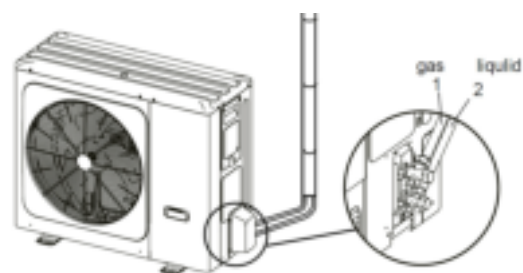

Step 2: Fastening

- Align the centre of the pipes and tighten the screw nuts by hand.
- Tighten the screw nuts with a spanner until they click.
- Torques.

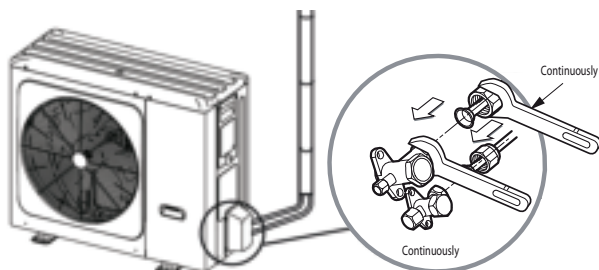

Step 3: Preventing foreign bodies from entering the unit

- Seal all pipe openings well with putty or a different type of insulation (available separately).
- If insects or small animals enter the outdoor unit, they can cause short circuits in the control cabinet.
- Lay the pipes. To do this, cover the coupling device of the indoor unit with insulation and fix in place with two adhesive tapes.
- Adequate thermal insulation is extremely important.

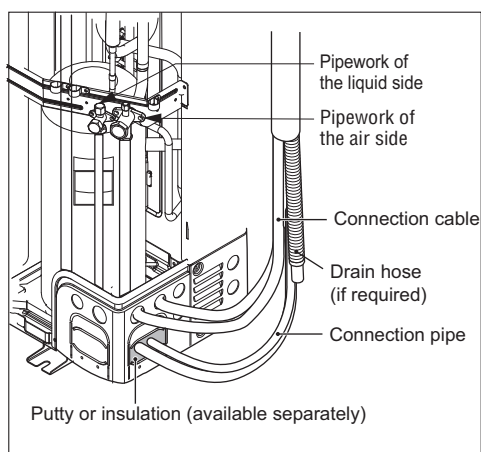

CAUTION!

Never open the valves of the outdoor component. Carry out the work from Cap. 7.2 on page 18 and Cap. 7.3 on page 20 first.

7.2 Electrical connections

7.2.1 Outdoor unit

NOTE

The DIP switches on the circuit boards in the outdoor unit have no function. The positions of the DIP switches must remain in their factory default and must not be changed!

Two cables must be connected on the outdoor unit:
A 'mains cable' and a 'data cable'

Both cables must be laid between the indoor and outdoor unit. The mains cable is used to supply the outdoor unit with power and the data cable is for communication between the outdoor and indoor component. The VDE directives and regulations and local conditions must be taken into account in the design and installation of the two cables.

The fusing of the outdoor unit and the indoor unit must be external.

The mains cable on the 6/10 kW outdoor unit must be three-core and be connected to the terminals L/N/PE (power supply). For the 14 kW outdoor unit, the mains cable must be 3-core or 5-core, depending on the version (230 V or 400 V), and be connected to terminals L1/N/PE or LI/L2/L3/N/PE.

- No cables with different thicknesses may be connected to the connecting terminal. (One of the cables may come loose during strong heat development.)
- Multiple cables of the same thickness must be connected as shown in the figure.

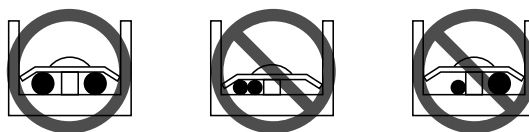

A shielded 2-core cable must be used as a data cable.

Connect communication terminal E/P/Q on the outdoor unit to the J9 BUS terminals on the control module in the indoor unit switch box.

The connections can be established as follows:

- Connecting terminal P (outdoor unit) to J9 negative (-) (indoor unit)
- Connecting terminal Q (outdoor unit) with J9 positive (+) (indoor unit)
- Connecting terminal E (outdoor unit) with J9 ground (o) (indoor unit)

To avoid interference and distortion of the communication signal, the communication cable should not be routed directly next to the mains cable. Create as much space as possible between the communication cable and the mains cable. The liquid and gas lines should be laid in the middle and the mains and communication cables to the sides.

7.2.2 Indoor unit

Two supply cables must be connected to the indoor unit: The power supply for the electric heating element and the control voltage for the integrated heat pump manager. (Load: 3~; 1x 5-core; control: 1~; 1x three-core) The VDE directives and regulations and local conditions must be taken into account in the design and installation of the cables.

i NOTE

The indoor unit can be configured for single-phase operation if required. For more detailed information, please refer to the enclosed electrical documentation.

i NOTE

The positions of the copper connection bridges in the terminals for the power supply must be complied with. The copper connection bridges are not connected when the unit is delivered in the factory default condition and are included with the unit. The copper connection bridges connected as soon as the pipe heating is operated at 230 V.

The supply cable for the output section of the heat pump (up to 5-core) is fed from the electricity meter of the heat pump via the utility blocking contactor (if required) into the heat pump (see heat pump operating instructions for supply voltage). An all-pole disconnecting device with a contact gap of at least 3 mm (e.g. utility blocking contactor or power contactor) and an all-pole circuit breaker with common tripping for all external conductors must be installed in the power supply for the heat pump (tripping current and characteristic in compliance with the device information).

The supply cable (1~L/N/PE~230 V, 50 Hz) for the heat pump manager must have a continuous voltage. For this reason, it should be tapped upstream from the utility blocking contactor or be connected to the household current, because otherwise important protection functions could be lost during a utility block. The correct control voltage must be ensured according to the general information leaflet/rating plate.

The utility blocking contactor (K22) with 3 main contacts (1/3/5 // 2/4/6) and an auxiliary contact (NO contact 13/14) should be dimensioned according to the heat pump output and must be supplied on-site. The NO contact of the utility blocking contactor (13/14) is connected to pin (1) (=DI1) of function block 0 (grey). **CAUTION! Extra-low voltage!**

The power supply must be connected to terminal strip X1 and the control voltage to terminal X1.1 230 V: IN on the indoor unit.

For detailed instructions on how to connect the external components as well as how the heat pump manager functions, please refer to the device connection diagram and the operating instructions supplied with the heat pump manager.

The 2nd heat generator is set to 6 kW heat output in the factory default condition. To reduce the output to 4 kW or 2 kW, one or both connection lines should not be connected and the ends should be insulated.

For detailed information, see circuit diagrams in the attachment.

The electrical cables can be fed into the device from above (upstream of the drinking water connections).

Connecting electronically regulated circulating pumps

Electronically regulated circulating pumps may have high starting currents, which may reduce the service life of the heat pump manager. If the starting current value is high, or is unknown, install a coupling relay. The coupling relay must be supplied by the customer. This is not necessary if the maximum permissible operating current of the heat pump manager (see specifications in the electrical documentation) is not exceeded by the electronically regulated circulating pump or a relevant approval has been issued by the pump manufacturer.

i NOTE

The high-efficiency pumps (UPH) are supplied with the relevant coupling relay for connecting and operating the electronically regulated circulating pump.

⚠ CAUTION!

It is not permitted to connect more than one electronically regulated circulating pump via a single relay output.

7.2.3 Frost protection

Regardless of the settings for the heat circulating pumps, they always run in heating, defrost and frost protection mode. In systems with multiple heating circuits, the 2nd and 3rd heat circulating pump has the same function.

⚠ CAUTION!

To ensure that the frost protection function on the heat pump works properly, the heat pump manager must remain connected to the power supply and flow must be maintained through the heat pump at all times.

⚠ CAUTION!

The primary pump (M11 - responsible for the heat source flow rate) and the secondary pump (M16 - responsible for the warm/cold water flow rate) must always be clamped to the heat pump manager in all cases. This is the only way to ensure the pump flows and returns necessary for operation and to ensure that the necessary safety measures are in place.

7.3 Final work

Once the pipes and electric cables have been connected, the pipes must be bent and a leak test must be carried out. The leak test must be carried out with particular care, as a refrigerant leak results in a direct reduction in output.

Leaks are also difficult to identify once the installation is complete.

7.3.1 Pipe bends

Bend the pipes by covering the connection cable and refrigerant pipe (between the indoor and outdoor unit) with insulation and fix the insulation in place with two adhesive tapes.

- 1) Fix the refrigerant pipe, mains cable and connection cable with adhesive tape from bottom to top. Fix the bound pipework along the wall.
- 2) Form a siphon to prevent water from entering the chamber and electrical components.
- 3) Fix the pipework to the wall using clamps or similar.

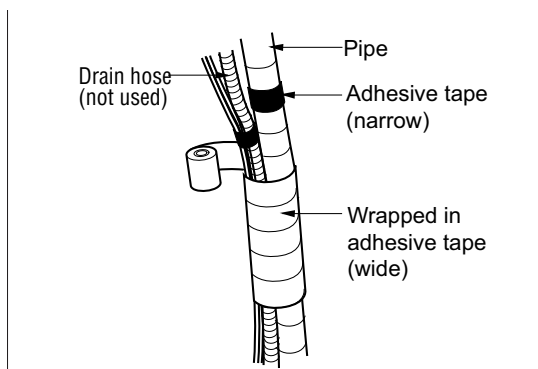

Wrap the pipework in adhesive tape

- 1) Fix the pipes, mains cable and connection cable with adhesive tape from bottom to top. If they are fixed from top to bottom, rain could enter into the pipes or cables.
- 2) Fix the bound pipework along the external wall with clamps or similar.
- 3) A siphon prevents water from entering the electrics.

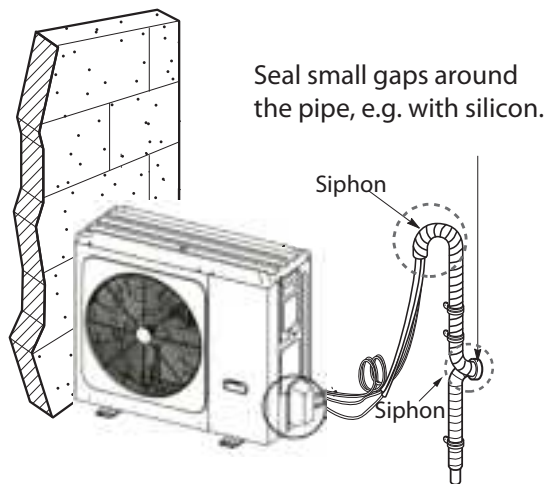
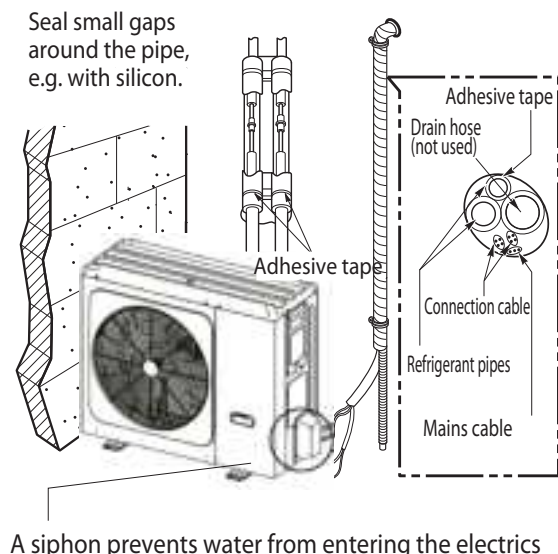

7.4 Leak test and evacuation

Air and moisture in the cooling system have unwanted effects as outlined below.

- 1) The pressure in the system increases.
- 2) The operating current increases.
- 3) The cooling (or heating) output falls.
- 4) Moisture in the cooling circuit can freeze and block the capillary tubes.
- 5) Water can cause corrosion on parts in the cooling system.

This means that the indoor and outdoor unit, as well as the connection pipe, must be checked for leaks and pumped empty to remove any non-condensable gases and moisture from the system.

7.4.1 Preparation

Ensure that each pipe (liquid and air side) between the indoor and outdoor unit is connected correctly and the wiring for the test operation has been carried out. Remove the maintenance valve caps from both the gas and liquid side of the outdoor unit. Ensure that both maintenance valves on the liquid and air side of the outdoor unit are closed at this point.

7.4.2 Leakage tightness test

- Connect the multi-way valve (with pressure gauges) and dry nitrogen gas cylinder with the filling hoses on this maintenance connection.

i NOTE

A multi-way valve must be used for the leak test. If no multi-way valve is available, an isolating valve can also be used. The "Hi" lever on the 3-way valve must be closed at all times.

- The system may be charged with max. 3.0 MPa dry nitrogen. The cylinder valve must be closed with a pressure of 3.0 MPa. The next step is to search for leaks with liquid soap.

i NOTE

In order to prevent liquid nitrogen from entering the cooling system, the top side of the gas cylinder must be higher than the bottom side when pressure is building in the system.

- 1) The gas cylinder is usually used in an upright position. Check all pipe connections (indoor and outdoor) and maintenance valves of the air and liquid side for leaks. Bubbles indicate a leak. The soap must be wiped away with a clean cloth.
- 2) If no leaks are identified in the system, reduce the nitrogen pressure by removing the filling hose connection from the gas cylinder. When the system pressure is normal again, the hose must be removed from the gas cylinder.

7.4.3 Evacuation

- 1) Connect the end of the filling hose mentioned above to the vacuum pump to pump the pipework and indoor unit empty. The levers "Lo" and "Hi" on the multi-way valve must be open. Start the vacuum pump. The duration of the pumping empty process varies with different lengths of the pipework and the pump output. The following table shows the time required for pumping empty.

Time required for suction with a vacuum pump 0.11 m ³ /hour.	
Length of the pipework less than 10 m	Length of the pipework more than 10 m
30 min. or longer	60 min. or longer
0.6 mbar or less	

- 2) Close the levers "Lo" and "Hi" on the multi-way valve at the desired vacuum pressure and switch off the vacuum pump.

Finally

- 1) Open the valve handle on the liquid side completely in an anti-clockwise direction with a maintenance valve key.
- 2) Open the handle of the valve on the gas side completely in an anti-clockwise direction.
- 3) Loosen the filling hose connected to the air side slightly from the maintenance connection to reduce the pressure, then remove the hose.
- 4) Tighten the screw nuts and caps on the air side maintenance connection again with an adjustment key. This process is very important to prevent leaks on the system.
- 5) Position the valve caps on the air and liquid side maintenance valves again and tighten. The purging with the vacuum pump is complete. The split heat pump is now ready for test operation.

8 Commissioning

8.1 General

To ensure that commissioning is performed correctly, it should only be carried out by an after-sales service technician authorised by the manufacturer. This may be a condition for an additional warranty (see "Warranty service").

8.2 Preparation

The following items must be checked prior to commissioning:

- All of the indoor unit connections must be installed as described in Cap. 6.1 on page 12.
- All of the outdoor unit connections must be installed as described in Cap. 7 on page 15.
- All valves which could impair the proper flow of the heating water in the heating circuit must be open.
- The air intake and air outlet paths must be clear.
- The settings of the heat pump manager must be adapted to the heating system in accordance with the manager's operating instructions.
- The heating water circuit, domestic hot water cylinder and buffer tank of the indoor unit must be completely filled and purged.
- Ensure that the condensate drain functions properly.
- The outflow from the heating water pressure relief valve must also function correctly.
- Purging the heating system:
Ensure that all heating circuits are open, purge the system at the highest position and refill water if necessary (comply with static minimum pressure).
- The hydraulic network must be flushed correctly before installing the heat pump. This includes the supply line to the heat pump. Only when flushing is complete can the heat pump be hydraulically integrated.
- The dirt traps present as standard or included for assembly must be inspected between 4 and 8 weeks after the heat pump is commissioned or changes made to the heating system and cleaned if necessary. Further maintenance intervals must be scheduled depending on the level of soiling, which must be defined and carried out by a suitably qualified person.

Special notes for the integration of heat pumps in existing systems (renovations):

The existing heat distribution network (pipe materials, connection types, etc.) and the existing heating systems (e.g. radiators, underfloor heating, etc.) can impact the quality of the water in existing systems. Particularly when welded steel pipes or pipes that are not oxygen diffusion-proof are used, deposits, scaling, silting or similar may be present that can cause damage in the heat pump system. This can result in a total failure of the heat pump. The following measures must be observed to avoid this:

- Compliance with the water properties and water quality
- Flushing of the hydraulic system
- Maintenance interval of the dirt traps

If silting or ferromagnetic particles are to be expected in the hydraulic network, dirt separators or magnetite separators must be installed on-site before the medium enters the heat pump. The maintenance intervals must be defined by a suitably qualified person.

8.3 Commissioning procedure

The heat pump is commissioned via the heat pump manager. Settings should be made in compliance with the heat pump manager's instructions.

The on-site overflow valve must be adjusted to the requirements of the respective heating system. Incorrect adjustment can lead to faulty operation and increased energy consumption. We recommend carrying out the following procedure to set the overflow valve correctly:

Close all heating circuits that may also be closed during operation (depending on how the heat pump is being used) so that the most unfavourable operating status with regard to the water flow is achieved. This normally means the heating circuits of the rooms on the south and west sides of the building. At least one heating circuit must remain open (e.g. bathroom).

The overflow valve should be opened far enough to produce the maximum temperature spread between the heat flow and heat return flow, listed in the following table, for the current heat source temperature. The temperature spread should be measured as close as possible to the indoor unit. The heating element of mono energy systems should be disconnected during commissioning.

Heat source temperature		Max. temperature spread between heating flow and return
from	to	
-20 °C	-15 °C	4 K
-14 °C	-10 °C	5 K
-9 °C	-5 °C	6 K
-4 °C	0 °C	7 K
1 °C	5 °C	8 K
6 °C	10 °C	9 K
11 °C	15 °C	10 K
16 °C	20 °C	11 K
21 °C	25 °C	12 K
26 °C	30 °C	13 K
31 °C	35 °C	14 K

At heating water temperatures under 7 °C, commissioning is not possible. The water in the buffer tank must be heated with the 2nd heat generator to at least 18 °C.

To ensure problem-free commissioning, the following procedure is to be implemented:

- 1) Close all consumer circuits.
- 2) Ensure that the heat pump has the correct water flow.
- 3) Use the manager to select the "winter" operating mode.
- 4) In the special functions menu, start the "Commissioning" program.
- 5) Wait until a return temperature of at least 25 °C has been reached.
- 6) Now slowly reopen the heating circuit valves in succession so that the heating water flow rate is constantly raised by slightly opening the respective heating circuit. The heating water temperature in the buffer tank must not be allowed to drop below 20 °C during this process. This ensures that the heat pump can be defrosted at any time.
- 7) When all heating circuits are fully open and a return temperature of at least 18 °C is maintained, the commissioning is complete.

⚠ CAUTION!

Operating the heat pump at low system temperatures may cause the heat pump to break down completely. After a prolonged power failure, the commissioning procedure detailed above must be followed.

9 Test points, maintenance and troubleshooting

If no faults have occurred up to this point, the unit can now be put into operation.

⚠ CAUTION!

Installation, maintenance and service work must be carried out by a specialist supplier or installer. Improper maintenance by the user can lead to serious consequences.

⚠ CAUTION!

Incorrect installation, maintenance or repair of this device may increase the risk of damage to property or personal injury.

⚠ CAUTION!

Always wear adequate personal protective equipment (protective gloves, safety glasses, etc.) when working with refrigerant.

⚠ CAUTION!

Maintenance and repair must only be carried out according to the recommendations of the unit manufacturer. Maintenance and repair work requiring the assistance of other skilled personnel may only be carried out by trained personnel.

Before commissioning the unit, run through the test points outlined in this chapter.

You will also find instructions for maintenance and troubleshooting here.

9.1 Checklist prior to commissioning

⚠ CAUTION!

Before opening the device, ensure that all electric circuits are disconnected from the power supply

Pos.	Category	Components	Test point
1	Electricity	Field wiring	<ul style="list-style-type: none"> ■ All switches with contacts with different polarities should be connected securely in accordance with the specified directives or laws. ■ Cable connections should only be made by trained specialist personnel. ■ Cable connections and electrical components available separately should comply with European and local directives. ■ Cable connections should be made in accordance with the circuit diagram provided with this unit.
2		Circuit breakers	<ul style="list-style-type: none"> ■ A circuit breaker (earth leakage breaker) with 30 mA should be installed. ■ The circuit breaker in the control cabinet of the indoor unit should be switched on before the unit is commissioned.
3		Earthing	<ul style="list-style-type: none"> ■ An earthing wire should be connected. Never connect an earthing wire to a gas pipe, water piping, a metal object of the building, a surge protection or similar.
4		Power supply unit	<ul style="list-style-type: none"> ■ Use a separate mains cable.
5		Cable connections of the terminal panel	<ul style="list-style-type: none"> ■ Connections on the terminal panel (in the control cabinet of the indoor unit) should be fixed in place securely enough.
6	Water pressure	Fill pressure	<ul style="list-style-type: none"> ■ After filling with water, the pressure gauge should show a pressure of 1.0 to 2.5 bar. The maximum pressure should not exceed 3.0 bar.
7		Purging	<ul style="list-style-type: none"> ■ While filling with water, the system should be purged via the purging hole. ■ If no water comes out after pressing on the tip (on the top side of the opening), the purging process is not yet complete. ■ If the system has been purged optimally, water sprays out like a fountain when pressing on the tip. Take care when testing the purging. Water could spray on your clothes.
8		Isolating valve	<ul style="list-style-type: none"> ■ Both isolating valves should be open.
11	Installing the unit	Maintenance of components	<ul style="list-style-type: none"> ■ There should be no visibly damaged components in the indoor unit.
12		Refrigerant leak	<ul style="list-style-type: none"> ■ Refrigerant leaks reduce the output of the unit. In the event of leaks, please inform an authorised after-sales service partner.
13		Electrical components	<ul style="list-style-type: none"> ■ After completing the work, make sure that all components are properly wired and that no live parts can be touched after closing the cover. Make sure that the covers are securely closed.

9.2 Maintenance

To maintain an optimal output on the split heat pump, regular checks and maintenance work should be carried out on the unit.

It is advisable to work through the following checklist at least once a year.

⚠ CAUTION!

Before opening the device, ensure that all electric circuits are disconnected from the power supply

⚠ CAUTION!

For cleaning and maintenance, especially when removing covers, the entire system must be disconnected from the power supply beforehand.

⚠ CAUTION!

Always wear adequate personal protective equipment (protective gloves, safety glasses, etc.) when working with refrigerant.

Pos.	Category	Components	Test point
1	Water	Water pressure	<ul style="list-style-type: none"> ■ In normal operation, the pressure gauge should show a pressure of 2.0 to 2.3 bar. ■ If the pressure is under 0.3 bar, water should be added.
2		Dirt trap (water filter)	<ul style="list-style-type: none"> ■ Close the isolating valves and remove the dirt trap. Clean the dirt trap. ■ When dismantling the dirt trap, water may flow out.
4	Electricity	Cable connections of the terminal panel	<ul style="list-style-type: none"> ■ Check the terminal panel for loose or faulty connections.

Maintenance must only be carried out according to the recommendations of the device manufacturer.

Only the cleaning agents specified by the manufacturer may be used for cleaning.

Incorrect maintenance or repair of this device may increase the risk of damage to property or personal injury.

Systems that are under pressure should be regularly checked for leaks.

9.3 Troubleshooting

If the split heat pump is experiencing problems during operation or is not working at all, check the following points.

⚠ CAUTION!

Before opening the device, ensure that all electric circuits are disconnected from the power supply.

9.3.1 Removing faults during operation

Pos.	Fault	Cause	Solution
1	Insufficient heating or cooling.	Incorrect setting of the target temperature.	<ul style="list-style-type: none"> ■ Check the setting of the heating curve on the heat pump manager
		Insufficient water filling.	<ul style="list-style-type: none"> ■ Check the pressure gauge and add water until the pressure gauge shows a pressure of 2.0 to 2.3 bar.
		Water flow is low.	<ul style="list-style-type: none"> ■ Check whether the dirt trap is heavily soiled. If so, the dirt trap must be cleaned. ■ Check whether the pressure indicator shows a pressure of at least 0.3 bar. ■ Check whether the water piping is blocked by soiling or limescale deposits.
2	Noises from the water pump	Purging has not been completed.	<ul style="list-style-type: none"> ■ Open the dust cap of the purging fitting and add water until the pressure gauge shows a pressure of 2.0 to 2.3 bar. ■ If no water comes out after pressing on the tip (on the top side of the opening), the purging process is not yet complete. If the system has been purged optimally, water sprays out like a fountain when pressing on the tip.
		Water pressure is low.	<ul style="list-style-type: none"> ■ Check whether the pressure indicator shows a pressure of at least 0.3 bar. ■ Check whether the equalising tank and pressure gauge are working correctly.
3	Water is drained off through the drain hose.	Too much water has been added.	<ul style="list-style-type: none"> ■ Open the lever of the safety valve and drain off more water until the pressure gauge shows a pressure of 2.0 to 2.3 bar.
		Equalising tank is damaged.	<ul style="list-style-type: none"> ■ Replace the equalising tank.
4	Domestic water is not heated	Thermal circuit breaker of the flange heater or pipe heater has been triggered	<ul style="list-style-type: none"> ■ Open the front cover of the indoor unit and press the Reset button
		Domestic water heating was deactivated.	<ul style="list-style-type: none"> ■ Check the settings on the heat pump manager on the indoor unit.

⚠ CAUTION!

When filling the system, ensure that only the specified refrigerant is used.

⚠ CAUTION!

When filling the system, please note the filling quantity of the system. If the pipeline is extended, a modified filling quantity may be required.

⚠ CAUTION!

The installation of piping should be restricted to the minimum possible.

⚠ CAUTION!

Always wear adequate personal protective equipment (protective gloves, safety glasses, etc.) when working with refrigerant.

⚠ CAUTION!

Work involving R32 refrigerant must only be carried out by experienced and adequately trained personnel.

⚠ CAUTION!

Only equipment and tools intended for the product, pressure and temperatures may be used for work on the unit.

⚠ CAUTION!

When checking for leaks, do not expose the device to a pressure higher than the maximum pressure declared on the type plate.

If the system needs to be completely refilled due to a fault or leakage, please proceed as follows:

- 1) Before starting work, make sure that the system is disconnected from the power supply and secured against being switched on again.
- 2) Extract refrigerant from the system. Do not release the refrigerant into the atmosphere unimpeded. When handling R32, only use equipment approved for the pressure and temperature.
- 3) If necessary, carry out repairs to the refrigeration circuit. Before starting work, make sure that no refrigerant is trapped in the refrigeration circuit. Refrain from using spark-producing tools. Do not work on the compressor with a soldering torch.
- 4) After the repair work has been completed, the system must be checked for leaks. It is recommended that you use dry nitrogen for this purpose. Never expose the system to higher test pressures than those specified on the device.
- 5) Evacuate the system and make sure that there is no oxygen or nitrogen in the pipe system.
- 6) Fill the system with the amount of refrigerant defined on the type plate. Make sure that the system is not overfilled. Modification or extension of the piping may result in a changed filling quantity of the refrigerating system. After completing the filling process, it is recommended to check the device and all connecting pipes once again for leakage using a suitable detection device.
- 7) After all work has been completed and the original condition of the system has been restored, the unit can be put back into operation.

⚠ CAUTION!

If the filling quantity changes, document it in an easily visible place (e.g. filling quantity on the type plate). Do not add more than the specified amount of refrigerant to the system.

9.4 Characteristic curve temperature sensor outdoor unit

NTC - 10		Air sensor (outdoor unit)													
Temperature in °C		-20	-15	-10	-5	-2	0	2	5	10	15	18	20	22	24
kΩ		105	80.2	58.2	44.0	37.4	33.6	30.3	25.9	20.2	15.8	13.8	12.5	11.4	10.5

Temperature in °C	25	26	28	30	32	34	36	38	40	50	60	70	80	90
kΩ	10.0	9.57	8.76	8.04	7.38	6.78	6.24	5.74	5.30	3.59	2.49	1.76	1.27	0.93

NTC - 5		Pipe-mounted sensors (outdoor unit)													
Temperature in °C		-20	-15	-10	-5	-2	0	2	5	10	15	18	20	22	24
kΩ		52.7	38.9	29.1	22.0	18.7	16.8	15.1	13.0	10.1	7.92	6.88	6.27	5.72	5.23

Temperature in °C	25	26	28	30	32	34	36	38	40	50	60	70	80	90
kΩ	5.00	4.78	4.38	4.02	3.69	3.39	3.12	2.87	2.65	1.79	1.24	0.88	0.64	0.47

NTC - 200		Hot gas sensor (output compressor)													
Temperature in °C		1	5	10	15	20	25	30	35	40	45	50	55	60	65
kΩ		525.00	448.00	326.00	294.33	242.20	200.00	167.57	138.03	133.80	98.00	82.00	64.50	59.00	50.71

Temperature in °C	70	75	80	85	90	95	100	105	110	115	120	130
kΩ	43.73	37.35	32.20	28.16	24.60	21.37	18.50	16.60	14.50	13.30	12.80	10.80

9.5 Characteristic curve temperature sensor indoor unit

9.5.1 Sensor characteristic curves

Temperature in °C	-20	-15	-10	-5	0	5	10			
NTC-2 in kΩ	14.6	11.4	8.9	7.1	5.6	4.5	3.7			
NTC-10 in kΩ	67.7	53.4	42.3	33.9	27.3	22.1	18.0			
	15	20	25	30	35	40	45	50	55	60
	2.9	2.4	2.0	1.7	1.4	1.1	1.0	0.8	0.7	0.6
	14.9	12.1	10.0	8.4	7.0	5.9	5.0	4.2	3.6	3.1

The temperature sensors to be connected to the heat pump manager must correspond to the sensor characteristic curve illustrated in Fig. 9.1 on page 28. The only exception is the outside temperature sensor included in the scope of supply of the heat pump (see Fig. 9.2 on page 28)

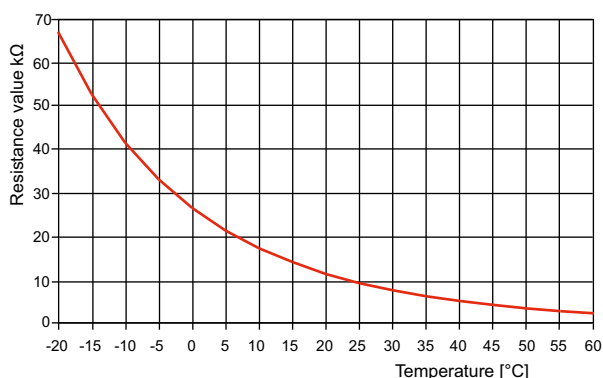

Fig. 9.1: Sensor characteristic curve NTC-10

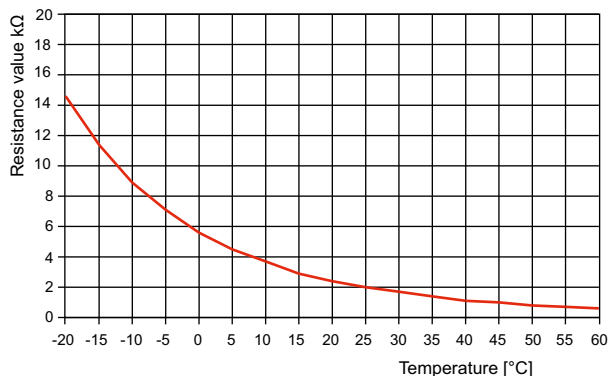

Fig. 9.2: Sensor characteristic curve NTC-2 according to DIN 44574 Outside temperature sensor

9.5.2 Mounting the outside temperature sensor

The outside temperature is measured via the heat source inlet sensor on the outdoor unit. Optionally, a separate outdoor temperature sensor can be mounted.

The temperature sensor must be mounted in such a way that all weather conditions are taken into consideration and the measured value is not falsified.

Install on the external wall of a heated room, if possible on the north or north-west side of the building

- Do not install in a "sheltered position" (e.g. in a wall niche or under a balcony)
- Not in the vicinity of windows, doors, exhaust air vents, external lighting or heat pumps
- Not to be exposed to direct sunlight at any time of year

Dimensioning parameters sensor cable

Conductor material	Cu
Cable length	50 m
Ambient temperature	35 °C
Routing type	B2 (DIN VDE 0298-4 / IEC 60364-5-52)
External diameter	4-8 mm

10 Cleaning / maintenance

10.1 Care

To protect the casing, avoid leaning anything against the unit or putting objects on the unit. Outdoor components can be wiped clean with a damp cloth and domestic cleaner.

⚠ CAUTION!

Never use cleaning agents containing sand, soda, acid or chloride, as these can damage the surfaces.

⚠ CAUTION!

For cleaning and maintenance, especially when removing covers, the entire system must be disconnected from the power supply beforehand.

10.2 Cleaning the heating system

The ingress of oxygen into the heating water circuit may result in the formation of oxidation products (rust), particularly if steel components are used. These enter the heating system via the valves, the circulating pumps and/or plastic pipes. A diffusion-resistant installation is therefore essential, especially with regard to the piping of underfloor heating systems.

Residue from lubricants and sealants may also contaminate the heating water.

In the event of severe contamination leading to a reduction in the performance of the liquefier in the heat pump, the system must be cleaned by a heating technician.

Based on current information, we recommend using a 5% phosphoric acid solution for cleaning purposes. However, if cleaning needs to be performed more frequently, a 5% formic acid solution should be used.

In both cases, the cleaning fluid should be at room temperature. We recommend flushing the heat exchanger in the direction opposite to the normal flow direction.

To prevent acidic cleaning agents from entering the heating system circuit, we recommend connecting the flushing device directly to the flow and return of the liquefier of the heat pump.

It is then important that the system be thoroughly flushed using appropriate neutralising agents to prevent any damage from being caused by cleaning agent residue remaining in the system.

Acids must be used with care and the regulations of the employers liability insurance associations must be adhered to.

The instructions of the cleaning agent manufacturer must always be observed.

11 Faults / troubleshooting

This heat pump is a quality product and is designed for trouble-free operation. Should a fault occur, however, it will be indicated on the heat pump manager display. In this case, consult the "Faults and troubleshooting" page in the operating instructions of the heat pump manager. If you cannot correct the fault yourself, please contact your after-sales service technician.

⚠ CAUTION!

Work on the system must only be performed by authorised and qualified after-sales service technicians.

12 Decommissioning / disposal

Before removing the heat pump, disconnect it from the power source and close all valves. The heat pump must be dismantled by trained personnel. Observe all environmental requirements regarding the recovery, recycling and disposal of materials and components in accordance with all applicable standards.

⚠ CAUTION!

The dismantling and handling of refrigerating machine oils and refrigerants are subject to local and national regulations. This work must only be carried out by specialist companies. Do not attempt to open, drain or dispose of the system yourself. There is a risk of injury and death.

13 Device information

1 Type and order code		LIA 0608HXCF M	LIA 0911HXCF M
2 Design			
Heat source		Air	Air
2.1 Version		Split reversible	Split reversible
2.2 Controller		WPM Touch	WPM Touch
2.3 Thermal energy metering		Yes	Yes
2.4 Installation location		Indoors/outdoors	Indoors/outdoors
2.5 Performance level		Variable	Variable
3 Operating limits			
3.1 Heating water flow/return	°C	up to 65 / from 12	up to 65 / from 12
3.2 Cooling water flow	°C	7 to 25	7 to 25
3.3 Air (heating)	°C	-25 to +35	-25 to +35
3.4 Air (cooling)	°C	-5 to +43	-5 to +43
4 Flow / sound			
4.1 Heating water flow / internal pressure differential			
Nominal flow according to EN 14511	m ³ /h / Pa	1.07 / 10900	1.72 / 26300
Free compression	Pa	63800	31600
Minimum heating water flow rate / internal pressure differential	m ³ /h/Pa	0.65 / 4750	1.07 / 10900
Free compression	Pa	71900	63800
4.2 Cooling water flow rate / internal pressure differential			
Nominal flow according to EN 14511	m ³ /h/Pa	1.07 / 10900	1.72 / 26300
Free compression	Pa	63800	31600
Minimum cooling water flow rate / internal pressure differential	m ³ /h/Pa	1.07 / 10900	1.72 / 26300
Free compression	Pa	63800	31600
4.3 Sound power level according to EN 12102 outdoors at A7/W55	dB(A)	58	60
4.4 Sound pressure level in 10 m distance, outdoors ¹	dB(A)	30	32
4.5 Sound power level reduced operation outdoors ²	dB(A)	53	55
4.6 Sound pressure level at a distance of 10 m, reduced operation, outdoors ^{1 2}	dB(A)	25	27
4.7 Sound power level according to EN 12102 indoors at A7/W55	dB(A)	42	42
4.8 Sound pressure level at a distance of 1 m, indoors ¹	dB(A)	31	31
4.9 Air flow, normal operation / reduced operation	m ³ /h	2770	4030
5 Dimensions, weight and filling quantities			
5.1 Device dimensions ³	Indoor unit Outdoor unit	H x W x D mm H x W x D mm	657 x 444 x 261 712 x 1008 x 426
5.2 Weight outdoor unit / incl. packing		kg	60 / 65.5
Weight indoor unit / incl. packing		kg	31.9 / 36.2
5.3 Device connections for heating		mm	28
5.4 Refrigerant / total filling weight		Type/kg	R32 / 1.5
5.5 GWP value / CO ₂ equivalent		--- / t	675 / 1.01
5.6 Lubricant / total filling quantity		Type	FW68S / 0.46
5.7 Volume of heating water in the outdoor unit		Litres	0
5.8 Buffer tank			
Nominal volume		Litres	25
Max. permissible operating temperature		°C	75
Max. permissible operating pressure		bar	3
5.9 Indoor unit			
Volume of heating water in the indoor unit		Litres	-
Heat exchanger area		m ²	-
Max. permissible operating temperature		°C	-
Max. permissible operating pressure		bar	-
5.10 Electrical pipe heater		kW	2, 4 or 6 ⁴
5.11 Start-to-leak pressure, safety valve		bar	2.5

6	Electrical connection			
6.1	Supply voltage / fusing	Outdoor unit	1~/N/PE 230 V (50 Hz) / C20A	1~/N/PE 230 V (50 Hz) / C20A
		Indoor unit	1~/N/PE 230 V (50 Hz) / B32A 3~/N/PE 400 V (50 Hz) / B13A	1~/N/PE 230 V (50 Hz) / B32A 3~/N/PE 400 V (50 Hz) / B13A
	RCD type		B	B
6.2	Control voltage / fusing		1~/N/PE 230 V (50 Hz) / C13A	1~/N/PE 230 V (50 Hz) / C13A
6.3	Degree of protection according to EN 60 529 Indoors / outdoors		IP 20 / IP X4	IP 20 / IP X4
6.4	Starting current limiter		Inverter	Inverter
6.5	Rotary field monitoring		Yes	Yes
6.6	Starting current	A	--	--
6.7	Nominal power consumption at A7/W35/max. consumption^{2 5}	kW	1.24 / 3.22 ⁶	2.00 / 3.91 ⁶
6.8	Nominal current at A7/W35 / cos φ	A	5.4 / 0.97	8.7 / 0.97
6.9	Nominal power consumption at A2/W35⁵	kW	1.26	2.02
6.10	Power consumption of compressor protection (per compressor)	W	--	--
6.11	Power consumption of fan	W	100	100
7	Complies with the European safety regulations		See CE declaration of conformity	See CE declaration of conformity
8	Additional model features			
8.1	Type of defrosting		Reverse circulation	Reverse circulation
8.2	Frost protection, condensate tray / Water in device protected against freezing⁷		Yes / Yes	Yes / Yes
8.3	Max. operating overpressure (heat source/heat sink)	bar	3.0	3.0
9	Heat output / cooling capacity / coefficients of performance (COP)			
9.1	Heat output / coefficient of performance (COP)^{5 8}		EN 14511	EN 14511
	at A-15 / W35	kW / ---⁹	4.00 / 2.34	6.34 / 2.46
	at A-7 / W35	kW / ---⁹	6.21 / 2.68	8.31 / 3.11
	at A-7 / W55	kW / ---⁹	5.22 / 1.96	7.05 / 1.97
	at A2 / W35	kW / ---⁹	5.50 / 3.95	8.20 / 4.05
	at A7 / W35	kW / ---⁹	6.20 / 5.00	10.00 / 5.00
	at A7 / W45	kW / ---⁹	6.35 / 3.75	10.00 / 3.80
	at A7 / W55	kW / ---⁹	6.90 / 2.91	9.72 / 3.04
	at A10 / W35	kW / ---⁹	7.35 / 5.02	10.00 / 5.13
	at A20 / W35	kW / ---⁹	6.98 / 5.91	10.70 / 6.72
	at A20 / W55	kW / ---⁹	6.81 / 3.60	9.85 / 3.88
9.2	Cooling capacity / coefficient of performance (COP)			
	at A25 / W10	kW / ---⁹	7.37 / 4.17	8.26 / 4.56
	at A25 / W20	kW / ---⁹	8.52 / 6.40	12.00 / 5.79
	at A35 / W10	kW / ---⁹	7.22 / 3.55	9.48 / 3.72
	at A35 / W20	kW / ---⁹	7.87 / 4.98	12.70 / 4.73

- The specified sound pressure level corresponds to the operating noise of the heat pump in heating operation with a flow temperature of 35 °C. The specified sound pressure level represents the free sound area level. The measured value can vary by up to 16 dB(A), depending on the installation location.
- In reduced operation, the heat output and the COP are reduced.
- Note that additional space is required for pipe connection, operation and maintenance.
- Factory setting 6 kW
- This data indicates the size and capacity of the system according to EN 14511. For an analysis of the economic and energy efficiency of the system, the bivalence point and the regulation should be taken into consideration. These figures are only achieved with clean heat exchangers. Instructions for care, commissioning and operation can be found in the relevant sections of the installation and operation instructions. The specified values have the following meaning, e.g. A7/W35: Heat source temperature 7 °C and heating water flow temperature 35 °C.
- Max. intake incl. pipe heater (state of supply)
- The heat circulating pump and the heat pump controller must always be ready for operation.
- Indoor and outdoor unit must be connected with two refrigerant pipes (high and low pressure). The length information refers to one section. The specified technical data applies to a refrigerant pipe length of 3-15 m per section. With a refrigerant pipe over a length of 15 metres, the heat output and the COP are reduced. The maximum permissible pipe length (without adjusting the refrigerant quantity) is 15 m. The refrigerant quantity pre-filled at the factory is sufficient up to this length. From a single pipe length of over 15 m, the refrigerant quantity must be adjusted. The maximum permissible pipe length with topping up of refrigerant is 30 m. The specified directives for routing refrigerant pipes and topping up refrigerant can be found in the installation and operating instructions.
- You can find additional performance data in the installation and operating instructions.

1 Type and order code				LIA 1316HXCF M	LIA 1316HXCF	
2 Design						
Heat source				Air	Air	
2.1	Version			Split reversible	Split reversible	
2.2	Controller			WPM Touch	WPM Touch	
2.3	Thermal energy metering			Yes	Yes	
2.4	Installation location			Indoors/outdoors	Indoors/outdoors	
2.5	Performance level			Variable	Variable	
3 Operating limits						
3.1	Heating water flow/return		°C	up to 65 / from 12	up to 65 / from 12	
3.2	Cooling water flow		°C	7 to 25	7 to 25	
3.3	Air (heating)		°C	-25 to +35	-25 to +35	
3.4	Air (cooling)		°C	-5 to +43	-5 to +43	
4 Flow / sound						
4.1 Heating water flow / internal pressure differential						
Nominal flow according to EN 14511			m³/h/Pa	2.2 / 35900	2.2 / 35900	
Free compression			Pa	7500	7500	
Minimum heating water flow rate / internal pressure differential			m³/h/Pa	1.5 / 19100	1.5 / 19100	
Free compression			Pa	23500	23500	
4.2 Cooling water flow rate / internal pressure differential						
Nominal flow according to EN 14511			m³/h/Pa	2.2 / 35900	2.2 / 35900	
Free compression			Pa	7500	7500	
Minimum cooling water flow rate / internal pressure differential			m³/h/Pa	2.2 / 35900	2.2 / 35900	
Free compression			Pa	7500	7500	
4.3	Sound power level according to EN 12102 outdoors at A7/W55		dB(A)	65	65	
4.4	Sound pressure level in 10 m distance, outdoors ¹		dB(A)	37	37	
4.5	Sound power level reduced operation outdoors ²		dB(A)	56	56	
4.6	Sound pressure level at a distance of 10 m, reduced operation, outdoors ^{1 2}		dB(A)	28	28	
4.7	Sound power level according to EN 12102 indoors at A7/W55		dB(A)	42	42	
4.8	Sound pressure level at a distance of 1 m, indoors ¹		dB(A)	31	31	
4.9	Air flow, normal operation / reduced operation		m³/h	4060	4060	
5 Dimensions, weight and filling quantities						
5.1	Device dimensions ³		Indoor unit Outdoor unit	H x W x D mm H x W x D mm	657 x 444 x 261 865 x 1118 x 523	657 x 444 x 264 865 x 1118 x 523
5.2	Weight outdoor unit / incl. packing				kg	97 / 110.5
	Weight indoor unit / incl. packing				kg	32.8 / 37.1
5.3	Device connections for heating				mm	28
5.4	Refrigerant / total filling weight				Type/kg	R32 / 1.84
5.5	GWP value / CO ₂ equivalent				--- / t	675 / 1.24
5.6	Lubricant / total filling quantity				Type	FW68S / 1.1
5.7	Volume of heating water in the outdoor unit				Litres	0
5.8	Buffer tank					
	Nominal volume				Litres	30
	Max. permissible operating temperature				°C	75
	Max. permissible operating pressure				bar	3
5.9	Indoor unit					
	Volume of heating water in the indoor unit				Litres	-
	Heat exchanger area				m²	-
	Max. permissible operating temperature				°C	-
	Max. permissible operating pressure				bar	-
5.10	Electrical pipe heater				kW	2, 4 or 6 ⁴
5.11	Start-to-leak pressure, safety valve				bar	2.5

6	Electrical connection				
6.1	Supply voltage / fusing	Outdoor unit	1~/N/PE 230 V (50 Hz) / C32A	3~/N/PE 400 V (50 Hz) / C16A	
		Indoor unit	1~/N/PE 230 V (50 Hz) / B32A	1~/N/PE 230 V (50 Hz) / B32A	
			3~/N/PE 400 V (50 Hz) / B13A	3~/N/PE 400 V (50 Hz) / B13A	
	RCD type		B	B	
6.2	Control voltage / fusing		1~/N/PE 230 V (50 Hz) / C13A	1~/N/PE 230 V (50 Hz) / C13A	
6.3	Degree of protection according to EN 60 529 Indoors / outdoors		IP 20 / IP X4	IP 20 / IP X4	
6.4	Starting current limiter		Inverter	Inverter	
6.5	Rotary field monitoring		Yes	Yes	
6.6	Starting current	A	--	--	
6.7	Nominal power consumption at A7/W35/max. consumption^{2 5}	kW	3.09 / 5.98 ⁶	3.09 / 4.4 ⁶	
6.8	Nominal current at A7/W35 / cos φ	A	13.4 / 0.97	7.73 / 0.9	
6.9	Nominal power consumption at A2/W35⁵	kW	2.65	2.65	
6.10	Power consumption of compressor protection (per compressor)	W	--	--	
6.11	Power consumption of fan	W	170	170	
7	Complies with the European safety regulations		See CE declaration of conformity	See CE declaration of conformity	
8	Additional model features				
8.1	Type of defrosting		Reverse circulation	Reverse circulation	
8.2	Frost protection, condensate tray / Water in device protected against freezing⁷		Yes / Yes	Yes / Yes	
8.3	Max. operating overpressure (heat source/heat sink)	bar	3.0	3.0	
9	Heat output / cooling capacity / coefficients of performance (COP)				
9.1	Heat output / coefficient of performance (COP)^{5 8}		EN 14511	EN 14511	
	at A-15 / W35	kW / ---⁹	9.57 / 2.43	9.57 / 2.43	
	at A-7 / W35	kW / ---⁹	12.70 / 2.79	12.70 / 2.79	
	at A-7 / W55	kW / ---⁹	11.30 / 2.01	11.30 / 2.01	
	at A2 / W35	kW / ---⁹	10.30 / 3.88	10.30 / 3.88	
	at A7 / W35	kW / ---⁹	15.50 / 4.59	15.50 / 4.59	
	at A7 / W45	kW / ---⁹	15.70 / 3.60	15.70 / 3.60	
	at A7 / W55	kW / ---⁹	14.50 / 2.95	14.50 / 2.95	
	at A10 / W35	kW / ---⁹	14.90 / 4.79	14.90 / 4.79	
	at A20 / W35	kW / ---⁹	14.60 / 5.65	14.60 / 5.65	
	at A20 / W55	kW / ---⁹	12.70 / 3.52	12.70 / 3.52	
9.2	Cooling capacity / coefficient of performance (COP)				
	at A25 / W10	kW / ---⁹	14.50 / 3.77	14.50 / 3.77	
	at A25 / W20	kW / ---⁹	17.00 / 4.24	17.00 / 4.24	
	at A35 / W10	kW / ---⁹	13.70 / 2.58	13.70 / 2.58	
	at A35 / W20	kW / ---⁹	15.30 / 3.45	15.30 / 3.45	

- The specified sound pressure level corresponds to the operating noise of the heat pump in heating operation with a flow temperature of 35 °C. The specified sound pressure level represents the free sound area level. The measured value can vary by up to 16 dB(A), depending on the installation location.
- In reduced operation, the heat output and the COP are reduced.
- Note that additional space is required for pipe connection, operation and maintenance.
- Factory setting 6 kW
- This data indicates the size and capacity of the system according to EN 14511. For an analysis of the economic and energy efficiency of the system, the bivalence point and the regulation should be taken into consideration. These figures are only achieved with clean heat exchangers. Instructions for care, commissioning and operation can be found in the relevant sections of the installation and operation instructions. The specified values have the following meaning, e.g. A7/W35: Heat source temperature 7 °C and heating water flow temperature 35 °C.
- Max. intake incl. pipe heater (state of supply)
- The heat circulating pump and the heat pump controller must always be ready for operation.
- Indoor and outdoor unit must be connected with two refrigerant pipes (high and low pressure). The length information refers to one section. The specified technical data applies to a refrigerant pipe length of 3-15 m per section. With a refrigerant pipe over a length of 15 metres, the heat output and the COP are reduced. The maximum permissible pipe length (without adjusting the refrigerant quantity) is 15 m. The refrigerant quantity pre-filled at the factory is sufficient up to this length. From a single pipe length of over 15 m, the refrigerant quantity must be adjusted. The maximum permissible pipe length with topping up of refrigerant is 30 m. The specified directives for routing refrigerant pipes and topping up refrigerant can be found in the installation and operating instructions.
- You can find additional performance data in the installation and operating instructions.

14 Performance values

14.1 Performance values, heating LIA 0608HXCF M

Maximum																											
DB	LWT																										
	25			30			35			40			45			50			55			60			65		
	HC	PI	COP	HC	PI	COP	HC	PI	COP	HC	PI	COP	HC	PI	COP	HC	PI	COP	HC	PI	COP	HC	PI	COP	HC	PI	COP
-25	2.57	1.49	1.72	2.25	1.53	1.46	2.14	1.67	1.28	1.91	1.64	1.17	1.71	1.57	1.09	/	/	/	/	/	/	/	/	/	/		
-20	3.64	1.56	2.34	3.34	1.86	1.80	2.88	2.03	1.42	2.56	2.08	1.23	2.33	2.08	1.12	2.19	2.04	1.07	1.84	1.86	0.99	/	/	/	/		
-15	4.43	1.49	2.97	4.19	1.53	2.73	4.00	1.71	2.34	3.61	1.87	1.93	3.08	2.01	1.53	2.70	2.02	1.34	2.26	1.88	1.20	2.13	2.02	1.05	/		
-10	5.75	1.69	3.41	5.50	1.84	2.99	5.11	1.99	2.57	4.83	2.18	2.22	4.64	2.24	2.07	4.13	2.41	1.72	3.80	2.24	1.69	3.32	2.30	1.44	/		
-7	6.55	1.77	3.71	6.30	1.92	3.28	6.21	2.17	2.86	5.79	2.32	2.50	5.57	2.38	2.35	5.29	2.63	2.01	5.22	2.66	1.96	4.57	2.61	1.75	/		
-5	6.54	1.64	3.98	6.32	1.79	3.52	6.14	1.99	3.09	5.97	2.18	2.74	5.84	2.30	2.54	5.44	2.44	2.23	5.31	2.64	2.01	4.73	2.59	1.83	/		
0	6.49	1.34	4.85	6.37	1.48	4.31	6.35	1.68	3.79	6.80	1.99	3.42	6.85	2.25	3.04	5.88	2.37	2.48	5.42	2.59	2.09	5.06	2.54	1.99	/		
5	7.04	1.31	5.37	6.71	1.50	4.48	6.88	1.62	4.25	6.96	1.89	3.69	6.99	2.12	3.29	6.37	2.27	2.81	6.11	2.46	2.48	5.74	2.53	2.27	4.92		
7	7.58	1.28	5.90	7.06	1.47	4.81	7.41	1.56	4.76	7.13	1.79	3.99	7.13	2.00	3.58	6.87	2.16	3.17	6.90	2.37	2.91	6.42	2.52	2.55	5.25		
10	7.43	1.21	6.12	7.11	1.36	5.24	7.35	1.46	5.02	7.37	1.75	4.21	7.32	1.93	3.78	7.01	2.09	3.35	6.93	2.28	3.04	6.27	2.41	2.60	5.57		
15	7.17	1.13	6.35	7.20	1.24	5.82	7.26	1.38	5.28	7.78	1.69	4.61	7.63	1.83	4.16	7.24	1.97	3.67	6.98	2.12	3.30	6.01	2.23	2.70	6.10		
20	6.93	0.97	7.15	6.97	1.11	6.28	6.98	1.18	5.91	7.21	1.54	4.70	7.42	1.68	4.42	7.28	1.81	4.02	6.81	1.89	3.60	5.98	1.95	3.06	/		
25	6.69	0.80	8.32	6.74	0.94	7.16	6.70	1.06	6.31	6.65	1.30	5.11	7.21	1.52	4.74	7.33	1.66	4.43	6.63	1.66	4.00	5.94	1.67	3.55	/		
30	6.74	0.71	9.53	6.83	0.85	8.02	6.83	0.94	7.27	6.56	1.09	6.01	7.05	1.40	5.05	6.91	1.40	4.92	6.60	1.57	4.21	6.01	1.57	3.83	/		
35	6.79	0.66	10.3	6.93	0.73	9.43	6.96	0.85	8.17	6.47	0.94	6.87	6.89	1.27	5.42	6.49	1.24	5.21	6.57	1.48	4.45	/	/	/	/		
40	7.26	0.64	11.4	7.37	0.73	10.2	7.28	0.81	9.02	7.12	0.97	7.34	7.34	1.20	6.12	6.93	1.22	5.68	/	/	/	/	/	/	/		
43	7.54	0.63	12.0	7.64	0.70	10.9	7.48	0.76	9.87	7.51	0.91	8.27	7.61	1.08	7.02	7.19	1.21	5.96	/	/	/	/	/	/	/		

Normal																											
DB	LWT																										
	25			30			35			40			45			50			55			60			65		
	HC	PI	COP	HC	PI	COP	HC	PI	COP	HC	PI	COP	HC	PI	COP	HC	PI	COP	HC	PI	COP	HC	PI	COP	HC	PI	COP
-25	2.37	1.35	1.76	2.07	1.37	1.51	1.95	1.50	1.30	1.77	1.51	1.17	1.61	1.49	1.08	/	/	/	/	/	/	/	/	/	/		
-20	3.33	1.37	2.43	3.04	1.65	1.85	2.60	1.78	1.46	2.34	1.87	1.25	2.16	1.92	1.13	2.04	1.88	1.08	1.77	1.78	1.00	/	/	/	/		
-15	4.01	1.29	3.11	3.77	1.33	2.83	3.57	1.47	2.43	3.27	1.65	1.98	2.73	1.76	1.56	2.41	1.76	1.37	2.08	1.70	1.22	1.98	1.88	1.05	/		
-10	5.15	1.43	3.61	4.89	1.57	3.12	4.51	1.69	2.66	4.33	1.91	2.27	4.21	2.01	2.10	3.76	2.15	1.75	3.46	2.03	1.71	3.06	2.13	1.44	/		
-7	6.24	1.62	3.86	6.05	1.80	3.36	6.10	2.00	3.05	5.61	2.21	2.54	5.40	2.25	2.40	5.07	2.45	2.07	5.15	2.58	2.00	4.28	2.39	1.79	/		
-5	5.89	1.40	4.20	5.64	1.54	3.66	5.26	1.64	3.21	5.26	1.81	2.90	5.10	1.93	2.64	4.31	1.87	2.30	4.28	2.06	2.07	3.94	2.12	1.86	/		
0	5.99	1.20	4.98	5.80	1.31	4.43	5.74	1.47	3.89	6.26	1.81	3.47	6.06	1.92	3.15	5.36	2.12	2.53	4.75	2.24	2.12	4.46	2.24	1.99	/		
5	6.43	1.16	5.56	6.06	1.31	4.64	6.16	1.39	4.42	6.36	1.68	3.78	6.13	1.78	3.45	5.76	1.99	2.89	5.40	2.13	2.54	5.01	2.19	2.29	4.03		
7	6.75	1.09	6.18	6.30	1.21	5.21	6.20	1.24	5.00	6.44	1.55	4.14	6.35	1.69	3.75	6.13	1.86	3.29	6.00	2.00	3.00	5.64	2.17	2.60	4.40		
10	6.68	1.02	6.52	6.22	1.13	5.49	6.49	1.26	5.17	6.59	1.50	4.39	6.62	1.73	3.83	6.47	1.88	3.44	6.04	1.94	3.11	5.76	2.17	2.65	4.54		
15	6.52	0.94	6.93	6.37	1.02	6.24	6.48	1.16	5.57	7.03	1.43	4.92	6.98	1.61	4.32	6.76	1.75	3.86	6.15	1.80	3.42	5.59	2.00	2.79	5.04		
20	6.34	0.81	7.85	6.20	0.91	6.79	6.27	1.00	6.28	6.55	1.30	5.05	6.82	1.48	4.62	6.84	1.61	4.25	6.03	1.60	3.76	5.58	1.82	3.07	/		
25	5.97	0.65	9.21	6.12	0.78	7.79	6.13	0.91	6.75	6.15	1.11	5.53	6.76	1.35	4.99	7.01	1.49	4.72	5.99	1.43	4.20	5.65	1.57	3.59	/		
30	6.04	0.57	10.6	6.24	0.71	8.79	6.29	0.80	7.84	6.10	0.93	6.55	6.64	1.24	5.35	6.64	1.26	5.28	6.00	1.35	4.46	5.75	1.47	3.91	/		
35	6.14	0.53	11.6	6.38	0.61	10.4	6.46	0.73	8.87	6.07	0.81	7.54	6.55	1.13	5.79	6.29	1.12	5.63	6.02	1.27	4.75	/	/	/	/		
40	6.66	0.52	12.9	6.67	0.59	11.3	6.57	0.67	9.86	6.49	0.80	8.11	6.78	1.03	6.59	6.53	1.06	6.19	/	/	/	/	/	/	/		
43	6.97	0.51	13.7	6.98	0.57	12.2	6.80	0.63	10.9	6.91	0.75	9.20	7.09	0.93	7.61	6.84	1.05	6.54	/	/	/	/	/	/	/		

Minimum																											
DB	LWT																										
	25			30			35			40			45			50			55			60			65		
	HC	PI	COP	HC	PI	COP	HC	PI	COP	HC	PI	COP	HC	PI	COP	HC	PI	COP	HC	PI	COP	HC	PI	COP	HC	PI	COP
-25	1.54	0.86	1.78	1.39	0.91	1.53	1.48	1.12	1.32	1.36	1.14	1.19	1.08	0.99	1.09	/	/	/	/	/	/	/	/	/	/		
-20	2.04	0.82	2.47	1.80	0.96	1.88	1.67	1.12	1.49	1.64	1.28	1.28	1.45	1.27	1.14	1.51	1.38	1.09	1.34	1.01	/	/	/	/	/		
-15	2.07	0.65	3.18	2.03	0.70	2.90	1.90	0.76	2.49	2.02	0.99	2.03	1.97	1.25	1.58	1.86	1.35	1.39	1.53	1.24	1.24	1.51	1.41	1.07	/		
-10	2.28	0.62	3.71	2.14	0.67	3.21	2.02	0.74	2.74	2.51	1.07	2.34	2.81	1.32	2.14	2.80	1.57	1.78	2.63	1.51	1.74	2.38	1.63	1.47	/		
-7	1.57	0.39	4.03	1.45	0.41	3.50	1.48	0.48	3.06	2.49	0.92	2.72	2.67	1.08	2.48	2.57	1.22	2.11	2.64	1.31	2.01	2.68	1.47	1.82	/		
-5	1.78	0.41	4.32	1.66	0.44	3.76	1.70	0.52	3.30	2.59	0.87	2.98	2.82	1.05	2.69	2.59	1.10	2.35	2.81	1.33	2.11	2.72	1.43	1.90	/		
0	1.74	0.34	5.15	1.82	0.40	4.58	1.77	0.44	4.02	2.93	0.82	3.59	3.02	0.93	3.23	2.99	1.15	2.59	2.85	1.31	2.17	3.00	1.47	2.04	/		
5	2.31	0.40	5.78	2.32	0.48	4.82	2.33	0.51	4.59	3.21	0.82	3.93	3.29	0.93	3.54	3.43	1.15	2.98	3.46	1.32	2.62	3.58	1.52	2.36	2.85		
7	2.71	0.42	6.44	2.65	0.49	5.37	2.73	0.53	5.32	3.36	0.78	4.32	3.85	0.99	3.88	4.26	1.25	3.41	4.38	1.41	3.10	4.23	1.57	2.69	3.33		
10	2.27	0.33	6.83	2.08	0.36	5.75	2.32	0.43	5.42	3.32	0.72	4.60	3.96	0.99	3.99	4.22	1.18	3.57	4.37	1.35	3.23	4.20	1.53	2.75	3.55		
15	2.81	0.38	7.31	2.83	0.43	6.59	2.84	0.48	5.89	3.60	0.69	5.20	4.22	0.93	4.53	4.46	1.10	4.05	5.03	1.40	3.58	4.39	1.56	2.82	3.84		
20	3.12	0.38	8.30	3.41	0.48	7.18	3.70	0.56	6.65	4.54	0.85	5.34	4.60	0.95	4.86	4.73	1.06	4.46	4.56	1.15	3.95	4.00	1.24	3.23	/		
25	3.68	0.38	9.73	3.97	0.48	8.24	4.22	0.59	7.15	4.85	0.83	5.85	5.19	0.99	5.24	5.50	1.11	4.96	4.76	1.08	4.41	4.34	1.15	3.78	/		
30	3.88	0.35	11.2	4.20	0.45	9.30	4.47	0.54	8.30	4.49	0.65	6.94	5.18	0.92	5.63	5.35	0.96	5.55	4.91	1.05	4.69	4.54	1.10	4.11	/		
35	4.55	0.37	12.3	4.71	0.43	11.0	4.57	0.49	9.40	4.46	0.56	7.99	5.10	0.84	6.09	5											

14.2 Performance values, heating

LIA 0911HXCF M

Maximum																													
DB	LWT																												
	25			30			35			40			45			50			55			60			65				
	HC	PI	COP	HC	PI	COP	HC	PI	COP	HC	PI	COP	HC	PI	COP	HC	PI	COP	HC	PI	COP	HC	PI	COP	HC	PI	COP		
-25	4.68	2.06	2.27	4.21	2.12	1.98	3.78	2.28	1.66	3.52	2.24	1.57	2.96	2.26	1.31	/	/	/	/	/	/	/	/	/	/	/			
-20	5.98	2.12	2.82	5.35	2.24	2.39	4.98	2.34	2.13	4.55	2.55	1.79	3.89	2.39	1.63	3.34	2.35	1.42	2.75	2.18	1.26	/	/	/	/	/			
-15	7.26	2.15	3.37	6.78	2.34	2.90	6.43	2.62	2.46	5.86	2.57	2.28	5.57	2.76	2.02	4.91	2.82	1.74	5.20	3.04	1.71	4.20	2.96	1.42	/	/			
-10	8.37	2.33	3.60	8.14	2.53	3.22	7.89	2.65	2.98	7.64	2.86	2.67	7.38	3.10	2.38	7.03	3.31	2.13	6.67	3.58	1.86	5.38	3.15	1.71	/	/			
-7	8.72	2.29	3.81	8.48	2.49	3.41	8.31	2.61	3.11	7.96	2.81	2.83	7.68	3.05	2.52	7.33	3.26	2.25	7.05	3.53	1.97	5.61	3.10	1.81	/	/			
-5	8.80	2.14	4.12	8.86	2.47	3.60	8.80	2.64	3.33	8.46	2.94	2.88	8.18	3.09	2.65	8.04	3.27	2.46	7.53	3.32	2.27	6.13	3.10	1.98	/	/			
0	9.03	1.83	4.94	9.36	2.31	4.05	9.56	2.55	3.76	9.25	2.93	3.16	8.89	3.10	2.87	8.82	3.27	2.70	8.18	3.31	2.47	6.99	3.30	2.12	/	/			
5	9.94	1.73	5.75	9.97	2.07	4.81	10.1	2.25	4.51	10.1	2.64	3.83	9.79	2.88	3.40	9.45	3.14	3.01	9.08	3.27	2.78	7.85	3.20	2.45	4.52	3.30	1.37		
7	10.5	1.77	5.94	10.3	1.97	5.21	10.3	2.09	4.93	10.5	2.50	4.18	10.3	2.73	3.77	9.83	3.05	3.22	9.72	3.20	3.04	8.23	2.96	2.78	4.85	3.11	1.56		
10	11.2	1.59	7.04	10.4	1.85	5.64	10.0	1.96	5.13	9.94	2.38	4.17	9.87	2.69	3.67	9.59	2.91	3.30	9.57	3.11	3.08	8.27	3.04	2.72	6.44	3.05	2.11		
15	11.4	1.41	8.10	10.6	1.64	6.49	10.2	1.73	5.90	10.1	2.11	4.80	10.1	2.39	4.22	9.78	2.58	3.80	9.76	2.76	3.54	8.43	2.70	3.13	6.56	2.71	2.43		
20	10.8	1.19	9.05	10.8	1.35	7.96	10.7	1.59	6.72	10.7	1.89	5.66	10.3	2.12	4.86	10.0	2.38	4.21	9.85	2.54	3.88	8.90	2.56	3.48	/	/	/		
25	9.94	1.04	9.59	10.0	1.17	8.44	9.82	1.38	7.12	9.82	1.64	6.00	9.46	1.84	5.15	9.22	2.07	4.46	9.06	2.20	4.11	8.18	2.22	3.69	/	/	/		
30	9.77	0.96	10.2	9.07	1.10	8.79	8.90	1.12	7.95	8.85	1.32	6.72	9.92	1.61	6.15	9.31	1.88	4.96	9.04	1.88	4.80	7.49	1.96	3.83	/	/	/		
35	10.2	0.95	10.7	9.44	1.03	9.15	9.25	1.11	8.30	9.21	1.32	6.97	10.3	1.61	6.40	9.69	1.87	5.17	9.42	1.90	4.96	/	/	/	/	/	/		
40	10.7	0.93	11.5	9.91	1.01	9.81	9.71	1.15	8.47	9.67	1.32	7.34	10.8	1.60	6.79	10.2	1.84	5.53	/	/	/	/	/	/	/	/	/		
43	11.0	0.91	12.0	10.2	0.96	10.6	10.0	1.08	9.25	9.96	1.23	8.07	11.2	1.47	7.58	10.5	1.68	6.25	/	/	/	/	/	/	/	/	/		
Normal																													
DB	LWT																												
	25			30			35			40			45			50			55			60			65				
	HC	PI	COP	HC	PI	COP	HC	PI	COP	HC	PI	COP	HC	PI	COP	HC	PI	COP	HC	PI	COP	HC	PI	COP	HC	PI	COP	HC	PI
-25	4.33	1.87	2.32	3.87	1.89	2.05	3.45	2.05	1.68	3.26	2.07	1.57	2.78	2.14	1.30	/	/	/	/	/	/	/	/	/	/	/	/		
-20	5.47	1.87	2.93	4.87	1.98	2.46	4.50	2.05	2.20	4.17	2.29	1.82	3.61	2.20	1.64	3.11	2.17	1.44	2.65	2.09	1.27	/	/	/	/	/			
-15	6.57	1.86	3.53	6.10	2.03	3.01	5.73	2.24	2.56	5.31	2.27	2.34	4.94	2.41	2.05	4.38	2.46	1.78	4.79	2.76	1.74	3.91	2.75	1.42	/	/			
-10	7.49	1.97	3.81	7.25	2.15	3.37	6.95	2.26	3.08	6.84	2.50	2.74	6.69	2.78	2.41	6.41	2.96	2.16	6.08	3.23	1.88	4.96	2.91	1.70	/	/			
-7	8.28	2.11	3.92	8.18	2.33	3.51	8.25	2.62	3.15	7.43	2.54	2.93	7.35	2.88	2.55	7.00	3.04	2.30	6.85	3.43	2.00	5.14	0.00	1.84	/	/			
-5	7.93	1.82	4.35	7.90	2.12	3.73	7.66	2.21	3.47	7.45	2.45	3.04	7.13	2.60	2.75	6.88	2.72	2.53	6.49	2.78	2.34	5.46	2.71	2.02	/	/			
0	8.33	1.64	5.06	8.52	2.05	4.15	8.63	2.24	3.86	8.53	2.66	3.20	7.87	2.65	2.97	8.03	2.92	2.75	7.30	2.87	2.54	6.16	2.91	2.11	/	/			
5	9.09	1.53	5.95	9.00	1.81	4.99	9.07	1.94	4.68	9.23	2.35	3.92	8.58	2.41	3.55	8.53	2.76	3.09	8.02	2.82	2.84	6.86	2.77	2.48	3.86	2.75	1.40		
7	10.2	1.69	6.05	9.98	1.85	5.40	10.0	2.00	5.00	10.1	2.37	4.29	10.0	2.63	3.80	9.58	2.92	3.28	9.50	3.06	3.10	7.70	2.72	2.83	4.29	2.66	1.61		
10	10.1	1.34	7.50	9.12	1.54	5.91	8.85	1.68	5.28	8.88	2.04	4.35	8.94	2.40	3.72	8.86	2.62	3.39	8.34	2.65	3.14	7.60	2.74	2.77	5.66	2.62	2.16		
15	10.3	1.18	8.83	9.40	1.35	6.96	9.13	1.47	6.22	9.16	1.79	5.12	9.22	2.10	4.38	9.14	2.29	3.99	8.60	2.34	3.67	7.84	2.42	3.23	5.97	2.39	2.50		
20	9.88	0.99	9.94	9.58	1.11	8.60	9.58	1.34	7.14	9.70	1.60	6.08	9.46	1.86	5.08	9.41	2.11	4.46	8.73	2.16	4.05	8.31	2.38	3.49	/	/	/		
25	8.86	0.83	10.6	8.98	0.98	9.18	8.99	1.18	7.63	9.10	1.40	6.49	8.87	1.63	5.43	8.82	1.85	4.76	8.19	1.89	4.32	7.79	2.09	3.73	/	/	/		
30	8.76	0.77	11.3	8.28	0.86	9.63	8.19	0.96	8.57	8.24	1.13	7.32	9.35	1.43	6.53	8.96	1.68	5.33	8.21	1.61	5.08	7.17	1.84	3.90	/	/	/		
35	9.19	0.76	12.0	8.69	0.86	10.1	8.59	0.95	9.01	8.65	1.13	7.65	9.81	1.43	6.84	9.39	1.68	5.59	8.63	1.63	5.29	/	/	/	/	/	/		
40	9.79	0.75	13.0	8.97	0.82	10.9	8.75	0.95	9.26	8.82	1.09	8.11	10.0	1.37	7.31	9.59	1.59	6.02	/	/	/	/	/	/	/	/	/		
43	10.2	0.74	13.7	9.32	0.79	11.9	9.10	0.89	10.2	9.16	1.02	8.98	10.4	1.27	8.21	9.96	1.45	6.85	/	/	/	/	/	/	/	/	/		
Minimum																													
DB	LWT																												
	25			30			35			40			45			50			55			60			65				
	HC	PI	COP	HC	PI	COP	HC	PI	COP	HC	PI	COP	HC	PI	COP	HC	PI	COP	HC	PI	COP	HC	PI	COP	HC	PI	COP	HC	PI
-25	2.81	1.19	2.35	2.61	1.26	2.08	2.61	1.53	1.71	2.50	1.56	1.60	1.87	1.43	1.31	/	/	/	/	/	/	/	/	/	/	/	/		
-20	3.35	1.12	2.99	2.89	1.15	2.50	2.89	1.29	2.24	2.91	1.57	1.85	2.41	1.46	1.66	2.31	1.59	1.45	2.01	1.57	1.28	/	/	/	/	/			
-15	3.39	0.94	3.61	3.29	1.07	3.08	3.06	1.17	2.62	3.28	1.37	2.40	3.56	1.71	2.08	3.39	1.88	1.81	3.53	2.00	1.76	2.98	2.07	1.44	/	/			
-10	3.32	0.85	3.91	3.18	0.92	3.47	3.11	0.98	3.17	3.97	1.41	2.82	4.47	1.82	2.46	4.78	2.17	2.20	4.62	2.40	1.92	3.87	2.22	1.74	/	/			
-7	2.09	0.51	4.14	1.95	0.54	3.64	2.05	0.61	3.37	3.52	1.14	3.08	3.77	1.41	2.67	3.82	1.62	2.36	3.99	1.93	2.07	3.60	1.91	1.88	/	/			
-5	2.39	0.53	4.48	2.32	0.60	3.84	2.48	0.70	3.57	3.67	1.17	3.13	3.95	1.41	2.80	4.13	1.60	2.58	4.26	1.79	2.38	3.76	1.83	2.06	/	/			
0	2.42	0.46	5.24	2.68	0.62	4.30	2.67	0.67	3.99	3.99	1.20	3.31	3.92	1.29	3.04	4.48	1.59	2.82	4.38	1.68	2.61	4.14	1.91	2.17	/	/			
5	3.26	0.53	6.18	3.45	0.67	5.18	3.43	0.71	4.86	4.65	1.14	4.07	4.61	1.26	3.66	5.08	1.60	3.18	5.14	1.76	2.92	4.89	1.92	2.55	2.87	2.02	1.42		
7	3.76	0.58	6.48	3.86	0.68	5.69	3.81	0.71	5.39	4.92	1.09	4.53	5.55	1.36	4.09	6.10	1.76	3.46	6.17	1.90	3.25	5.41	1.85	2.93	3.19	1.96	1.63		
10	3.43	0.44	7.86	3.05	0.49	6.19	3.17	0.57	5.54	4.47	0.98	4.55	5.34	1.38	3.86	5.78	1.64	3.52	6.04	1.85	3.27	5.54	1.92	2.88	4.38	1.98	2.22		
15	4.48	0.48	9.32	4.17	0.57	7.35	4.00	0.61	6.58	4.69	0.87	5.40	5.58	1.21	4.59	6.03	1.44	4.18	7.03	1.83	3.85	6.16	1.88	3.27	4.40	1.71	2.56		
20	4.86	0.46	10.5	5.27	0.58	9.10	5.66	0.75	7.56	6.73	1.05	6.44	6.38	1.19	5.34	6.51	1.39	4.68	6.60	1.55	4.25	5.96	1.62	3.67	/	/	/		
25	5.47	0.49	11.2	5.84	0.60	9.72	6.19	0.77	8.07	7.17	1.04	6.87	6.81	1.19	5.70	6.92	1.38	5.00	6.51	1.43	4.54	5.97	1.52						

14.3 Performance values, heating LIA 1316HXCF (M)

Maximum																											
DB	LWT																										
	25			30			35			40			45			50			55			60			65		
	HC	PI	COP	HC	PI	COP	HC	PI	COP	HC	PI	COP	HC	PI	COP	HC	PI	COP	HC	PI	COP	HC	PI	COP	HC	PI	COP
-25	6.60	3.09	2.14	6.76	3.20	2.11	5.43	3.18	1.71	4.89	3.35	1.46	4.47	3.47	1.29	/	/	/	/	/	/	/	/	/	/		
-20	8.26	3.22	2.57	8.30	3.30	2.52	7.79	3.58	2.18	6.89	3.65	1.89	6.25	3.61	1.73	5.42	3.61	1.50	5.14	3.87	1.33	/	/	/	/		
-15	9.61	3.40	2.82	9.57	3.65	2.62	9.57	3.94	2.43	8.57	3.95	2.17	7.63	4.12	1.85	7.01	4.32	1.62	6.46	4.58	1.41	6.01	5.05	1.19	/		
-10	11.9	3.81	3.12	11.4	4.18	2.73	11.0	4.44	2.47	10.6	4.70	2.26	9.64	4.73	2.04	9.07	5.01	1.81	8.72	5.21	1.67	6.73	5.30	1.27	/		
-7	13.7	4.02	3.41	12.9	4.28	3.02	12.7	4.55	2.79	12.3	4.94	2.49	11.9	5.17	2.31	11.0	5.33	2.07	11.3	5.46	2.01	8.02	5.31	1.51	/		
-5	13.9	3.78	3.68	13.2	3.87	3.41	12.5	4.16	2.99	12.6	4.61	2.73	12.1	4.99	2.42	11.2	5.24	2.13	11.1	5.32	2.09	8.25	5.06	1.63	/		
0	14.3	3.40	4.21	13.7	3.54	3.87	12.4	3.82	3.26	13.0	4.32	3.01	12.7	4.85	2.62	11.9	4.99	2.38	11.8	5.19	2.27	9.34	5.48	1.70	/		
5	15.4	2.93	5.25	14.9	3.30	4.51	14.3	3.63	3.94	14.3	3.95	3.61	14.2	4.59	3.11	13.8	4.98	2.77	13.8	5.18	2.66	11.7	5.38	2.17	9.76		
7	16.3	2.81	5.80	15.6	3.15	4.94	15.5	3.37	4.59	15.6	3.86	4.04	15.7	4.35	3.60	15.0	4.81	3.11	14.5	4.92	2.95	13.2	5.20	2.54	10.4		
10	15.5	2.28	6.81	15.5	2.89	5.36	14.9	3.10	4.79	15.3	3.60	4.24	15.0	4.08	3.67	15.3	4.62	3.31	14.2	4.60	3.08	13.2	4.91	2.69	11.2		
15	15.3	2.01	7.62	15.2	2.62	5.79	15.2	2.94	5.16	15.8	3.56	4.45	15.5	3.98	3.89	15.3	4.37	3.51	13.0	4.02	3.24	12.7	4.48	2.84	11.9		
20	14.9	1.78	8.35	14.8	2.20	6.74	14.6	2.59	5.65	15.2	3.04	5.01	15.1	3.42	4.42	15.0	3.84	3.90	12.7	3.62	3.52	11.0	3.77	2.92	/		
25	14.9	1.64	9.08	14.7	1.92	7.69	14.6	2.38	6.15	14.9	2.68	5.57	14.7	2.98	4.95	14.7	3.43	4.30	12.5	3.28	3.80	10.2	3.40	2.99	/		
30	15.3	1.55	9.82	14.8	1.80	8.21	14.9	2.10	7.09	15.1	2.42	6.22	15.0	2.80	5.36	14.6	3.14	4.65	12.8	2.93	4.37	10.3	3.40	3.04	/		
35	16.0	1.45	11.1	15.4	1.70	9.04	15.0	1.87	8.02	15.5	2.26	6.86	15.3	2.65	5.77	14.8	2.95	5.00	13.0	2.77	4.69	/	/	/	/		
40	16.2	1.40	11.6	16.4	1.59	10.3	16.2	1.89	8.57	16.0	2.20	7.26	15.8	2.59	6.08	15.0	2.78	5.38	/	/	/	/	/	/	/		
43	16.5	1.36	12.2	16.7	1.54	10.8	16.5	1.88	8.81	16.3	2.12	7.69	16.1	2.56	6.27	15.2	2.73	5.54	/	/	/	/	/	/	/		

Normal																											
DB	LWT																										
	25			30			35			40			45			50			55			60			65		
	HC	PI	COP	HC	PI	COP	HC	PI	COP	HC	PI	COP	HC	PI	COP	HC	PI	COP	HC	PI	COP	HC	PI	COP	HC	PI	COP
-25	5.65	2.48	2.27	5.75	2.55	2.25	4.57	2.55	1.79	4.19	2.76	1.51	3.88	2.97	1.30	/	/	/	/	/	/	/	/	/	/		
-20	7.27	2.63	2.77	7.27	2.67	2.72	6.75	2.92	2.32	6.07	3.06	1.99	5.48	3.08	1.78	4.77	3.08	1.55	4.69	3.52	1.33	/	/	/	/		
-15	8.03	2.63	3.06	7.94	2.79	2.85	7.86	3.03	2.60	7.16	3.12	2.29	6.24	3.26	1.91	5.76	3.42	1.68	5.41	3.81	1.42	5.09	4.31	1.18	/		
-10	9.80	2.96	3.31	9.36	3.22	2.91	8.89	3.43	2.59	8.76	3.74	2.34	8.07	3.85	2.09	7.63	4.08	1.87	7.34	4.26	1.72	5.73	4.44	1.29	/		
-7	12.7	3.56	3.56	12.2	3.94	3.09	12.0	4.29	2.80	11.9	4.46	2.66	11.8	5.02	2.35	10.9	5.15	2.11	11.0	5.37	2.05	7.41	4.77	1.55	/		
-5	11.6	2.89	4.00	10.8	2.96	3.66	9.98	3.11	3.21	10.2	3.45	2.95	9.68	3.77	2.57	8.78	3.96	2.22	8.83	4.05	2.18	6.77	4.04	1.68	/		
0	11.4	2.48	4.59	10.8	2.58	4.17	9.52	2.72	3.50	10.1	3.08	3.27	9.74	3.48	2.79	8.78	3.62	2.42	8.78	3.70	2.38	7.18	4.08	1.76	/		
5	12.4	2.15	5.78	11.9	2.42	4.90	11.1	2.60	4.27	11.2	2.83	3.96	11.1	3.31	3.35	10.5	3.60	2.92	10.6	3.77	2.81	9.31	4.11	2.27	8.06		
7	15.2	2.43	6.26	14.5	2.77	5.24	14.5	3.09	4.70	14.6	3.52	4.15	14.2	3.89	3.65	14.0	4.40	3.40	13.8	4.60	3.00	12.3	4.73	2.61	9.71		
10	12.3	1.63	7.53	12.1	2.07	5.85	11.3	2.17	5.22	11.8	2.52	4.67	11.4	2.87	3.97	11.4	3.30	3.46	10.6	3.31	3.21	10.3	3.71	2.78	9.11		
15	12.2	1.43	8.50	11.9	1.87	6.37	11.6	2.05	5.67	12.3	2.49	4.94	11.9	2.80	4.25	11.5	3.11	3.70	9.84	2.88	3.41	10.0	3.38	2.96	9.68		
20	11.7	1.25	9.40	11.5	1.54	7.49	11.1	1.77	6.27	11.7	2.08	5.62	11.5	2.35	4.47	11.1	2.68	4.16	9.53	2.55	3.74	8.54	2.78	3.07	/		
25	11.8	1.15	10.2	11.6	1.35	8.55	11.1	1.63	6.82	11.5	1.66	6.93	11.3	2.06	5.46	11.0	2.41	4.58	9.40	2.32	4.04	7.95	2.53	3.14	/		
30	12.2	1.11	11.0	11.7	1.29	9.07	11.4	1.46	7.81	11.7	1.54	7.64	11.6	2.05	5.63	11.0	2.24	4.92	9.74	2.13	4.56	8.17	2.58	3.17	/		
35	13.0	1.06	12.3	12.4	1.25	9.93	11.8	1.36	8.63	12.3	1.67	7.39	12.0	1.96	6.10	11.4	2.13	5.33	10.1	2.05	4.93	/	/	/	/		
40	13.5	1.04	13.0	13.6	1.19	11.4	13.1	1.41	9.28	13.0	1.65	7.88	12.7	1.96	6.48	11.8	2.04	5.78	/	/	/	/	/	/	/		
43	14.1	1.02	13.8	14.1	1.17	12.1	13.6	1.41	9.61	13.5	1.61	8.40	13.2	1.96	6.73	12.2	2.04	5.99	/	/	/	/	/	/	/		

Minimum																											
DB	LWT																										
	25			25			25			25			25			25			25			25			25		
	HC	PI	COP	HC	PI	COP	HC	PI	COP	HC	PI	COP	HC	PI	COP	HC	PI	COP	HC	PI	COP	HC	PI	COP	HC	PI	COP
-25	3.76	1.62	2.33	4.02	1.74	2.30	3.54	1.94	1.82	3.33	2.17	1.54	3.00	2.29	1.31	/	/	/	/	/	/	/	/	/	/		
-20	4.58	1.63	2.80	4.77	1.73	2.76	4.40	1.87	2.35	4.02	1.99	2.02	4.06	2.31	1.76	3.79	2.47	1.54	3.65	2.76	1.32	/	/	/	/		
-15	5.24	1.68	3.13	5.40	1.85	2.91	5.31	2.00	2.66	4.91	2.09	2.35	4.88	2.56	1.91	4.84	2.87	1.68	4.52	3.17	1.43	4.33	3.65	1.19	/		
-10	5.05	1.47	3.44	5.08	1.68	3.02	4.76	1.79	2.66	4.80	1.99	2.41	5.01	2.35	2.13	5.17	2.71	1.90	5.40	3.08	1.76	4.51	3.43	1.32	/		
-7	5.14	1.34	3.84	4.55	1.35	3.36	4.57	1.48	3.10	4.96	1.77	2.80	6.21	2.46	2.52	5.96	2.71	2.20	6.25	2.90	2.15	5.22	3.26	1.60	/		
-5	5.35	1.28	4.17	4.78	1.25	3.81	4.61	1.38	3.34	5.19	1.69	3.07	6.40	2.41	2.65	6.15	2.69	2.28	6.46	2.88	2.24	5.44	3.15	1.73	/		
0	5.73	1.19	4.80	5.34	1.22	4.36	4.79	1.31	3.66	5.57	1.63	3.42	6.92	2.39	2.90	6.61	2.67	2.48	6.90	2.81	2.46	6.17	3.39	1.82	/		
5	6.23	1.03	6.07	5.89	1.14	5.15	5.58	1.24	4.49	6.18	1.49	4.16	7.86	2.25	3.49	7.86	2.59	3.03	8.68	2.98	2.91	7.95	3.38	2.35	6.88		
7	6.48	0.96	6.75	6.03	1.06	5.68	5.92	1.12	5.27	6.64	1.42	4.68	8.50	2.09	4.07	8.43	2.46	3.43	9.05	2.78	3.25	8.88	3.21	2.77	7.25		
10	6.34	0.80	7.93	6.18	1.00	6.16	5.84	1.06	5.50	6.66	1.35	4.92	8.28	2.00	4.15	8.77	2.40	3.65	8.96	2.67	3.36	9.02	3.10	2.91	7.95		
15	6.01	0.67	8.90	5.97	0.89	6.68	5.93	1.00	5.94	7.33	1.42	5.18	8.59	1.94	4.42	9.47	2.43	3.89	8.45	2.38	3.55	9.04	2.93	3.09	8.72		
20	5.95	0.60	9.84	5.93	0.76	7.85	5.83	0.89	6.57	7.16	1.22	5.88	8.48	1.68	5.06	9.35	2.14	4.36	8.36	2.15	3.89	7.88	2.47	3.19	/		
25	6.09	0.57	10.7	6.05	0.68	8.95	5.96	0.83	7.15	7.17	1.10	6.54	8.42	1.48	5.67	9.33	1.94	4.80	8.32	1.98	4.21	7.38	2.26	3.27	/		
30	7.11	0.62	11.5	7.26	0.76	9.49	8.10	1.01	8.02	8.43	1.20	7.05	8.68	1.46	5.92	9.37	1.81	5.17	8.70	1.81	4.80	7.34	2.20	3.33	/		
35	7.63	0.59	13.0	7.69	0.73	10.5	8.32	0.91	9.15	8.83	1.13	7.84	8.98	1.40	6.42	9.63	1.72	5.61	8.97	1.7							

14.4 Performance values, cooling

LIA 0608HXCF M

Maximum															
DB	LWT														
	5			10			15			20			25		
	CC	PI	EER	CC	PI	EER	CC	PI	EER	CC	PI	EER	CC	PI	EER
-5	/	/	/	/	/	/	5.27	0.59	8.93	6.38	0.55	11.53	6.77	0.64	10.62
0	/	/	/	/	/	/	5.05	0.69	7.28	6.16	0.66	9.39	6.55	0.74	8.85
5	/	/	/	/	/	/	4.55	0.79	5.74	5.66	0.76	7.48	6.05	0.84	7.20
10	/	/	/	/	/	/	6.32	1.13	5.61	6.90	1.01	6.83	7.45	0.95	7.88
15	/	/	/	5.89	1.10	5.33	8.09	1.46	5.55	8.14	1.26	6.44	8.85	1.05	8.43
20	5.41	1.38	3.93	6.63	1.43	4.62	8.16	1.49	5.47	8.33	1.30	6.42	8.98	1.10	8.15
25	7.16	1.80	3.98	7.37	1.77	4.17	8.23	1.53	5.39	8.52	1.33	6.40	9.12	1.15	7.90
30	6.50	1.85	3.51	7.29	1.90	3.84	7.77	1.65	4.72	8.19	1.46	5.63	8.77	1.30	6.75
35	5.84	1.90	3.07	7.22	2.03	3.55	7.31	1.76	4.15	7.87	1.58	4.98	8.43	1.44	5.84
40	3.80	1.51	2.52	5.08	1.81	2.81	5.91	1.73	3.41	6.63	1.68	3.95	7.88	1.64	4.80
43	2.58	1.15	2.24	3.80	1.52	2.51	5.08	1.56	3.26	5.88	1.57	3.74	7.55	1.59	4.73
Normal															
DB	LWT														
	5			10			15			20			25		
	CC	PI	EER	CC	PI	EER	CC	PI	EER	CC	PI	EER	CC	PI	EER
-5	/	/	/	/	/	/	4.24	0.42	10.18	5.19	0.38	13.72	5.50	0.42	12.96
0	/	/	/	/	/	/	4.07	0.48	8.48	5.02	0.44	11.39	5.33	0.48	11.01
5	/	/	/	/	/	/	3.64	0.58	6.31	4.54	0.53	8.61	4.91	0.58	8.49
10	/	/	/	/	/	/	5.08	0.82	6.18	5.55	0.71	7.86	6.06	0.65	9.31
15	/	/	/	4.42	0.78	5.65	6.79	1.15	5.89	7.00	0.99	7.06	7.44	0.80	9.29
20	4.22	1.02	4.14	5.36	1.08	4.96	6.80	1.16	5.88	7.17	1.03	6.94	7.82	0.87	8.98
25	5.67	1.35	4.21	6.05	1.35	4.49	6.96	1.21	5.74	7.44	1.07	6.98	8.05	0.91	8.85
30	5.23	1.40	3.74	6.08	1.48	4.10	6.67	1.32	5.06	7.25	1.20	6.05	7.85	1.06	7.44
35	4.54	1.41	3.22	5.93	1.55	3.83	6.02	1.35	4.47	6.87	1.28	5.36	7.69	1.20	6.39
40	3.10	1.15	2.70	4.30	1.42	3.03	5.15	1.40	3.68	5.95	1.37	4.34	7.15	1.32	5.41
43	2.12	0.91	2.33	2.99	1.15	2.59	4.04	1.18	3.43	5.04	1.25	4.04	5.97	1.15	5.18
Minimum															
DB	LWT														
	5			10			15			20			25		
	CC	PI	EER	CC	PI	EER	CC	PI	EER	CC	PI	EER	CC	PI	EER
-5	/	/	/	/	/	/	2.75	0.25	10.92	3.35	0.23	14.26	3.57	0.27	13.17
0	/	/	/	/	/	/	2.64	0.29	9.00	3.25	0.28	11.72	3.47	0.31	11.08
5	/	/	/	/	/	/	1.96	0.28	6.95	2.46	0.27	9.16	2.64	0.30	8.84
10	/	/	/	/	/	/	2.81	0.41	6.87	3.10	0.37	8.44	3.36	0.34	9.78
15	/	/	/	2.71	0.45	5.99	3.64	0.58	6.29	3.50	0.45	7.80	4.25	0.41	10.32
20	2.13	0.50	4.30	2.35	0.45	5.17	3.38	0.54	6.23	3.95	0.54	7.32	4.44	0.47	9.50
25	2.72	0.63	4.31	2.50	0.53	4.72	3.29	0.54	6.04	3.92	0.53	7.33	4.38	0.47	9.28
30	2.48	0.65	3.81	2.49	0.58	4.30	3.12	0.59	5.30	3.79	0.59	6.38	4.23	0.55	7.72
35	2.07	0.62	3.31	2.75	0.69	4.00	3.01	0.63	4.79	3.66	0.63	5.81	4.23	0.62	6.84
40	1.40	0.52	2.69	2.01	0.64	3.12	2.52	0.66	3.82	3.18	0.71	4.50	4.07	0.74	5.51
43	0.73	0.31	2.38	1.43	0.53	2.68	2.11	0.59	3.57	2.57	0.62	4.17	3.80	0.71	5.38

Abbreviations:

LWT: Flow (°C)

DB: Outside temperature (°C)

HC: Heat output (kW)

PI: Power consumption (kW)

14.5 Performance values, cooling LIA 0911HXCF M

Maximum															
DB	LWT														
	5			10			15			20			25		
	CC	PI	EER	CC	PI	EER	CC	PI	EER	CC	PI	EER	CC	PI	EER
-5	/	/	/	/	/	/	6.83	0.69	9.92	8.79	0.82	10.66	9.35	0.77	12.13
0	/	/	/	/	/	/	6.61	0.77	8.56	7.76	0.81	9.61	8.30	0.76	10.88
5	/	/	/	/	/	/	6.38	0.89	7.19	6.74	0.79	8.56	7.25	0.75	9.63
10	/	/	/	/	/	/	6.55	0.75	8.73	8.17	0.80	10.18	8.80	0.86	10.22
15	/	/	/	6.30	1.07	5.89	7.61	1.03	7.35	9.48	1.13	8.38	10.64	1.20	8.84
20	6.20	1.28	4.86	7.19	1.39	5.17	8.67	1.45	5.97	10.79	1.64	6.57	12.49	1.68	7.45
25	7.13	1.68	4.24	8.26	1.81	4.56	9.87	1.88	5.24	12.00	2.07	5.79	13.93	2.17	6.42
30	8.06	2.17	3.71	9.34	2.31	4.05	11.08	2.40	4.62	13.21	2.57	5.14	15.37	2.79	5.51
35	8.13	2.48	3.12	9.48	2.43	3.72	11.03	2.62	4.21	12.70	2.68	4.73	14.51	2.87	5.06
40	6.61	2.52	2.62	7.42	2.37	3.14	8.88	2.53	3.51	10.23	2.51	4.07	12.27	2.83	4.34
43	5.09	2.28	2.23	5.64	2.19	2.58	6.73	2.13	3.16	8.15	2.17	3.75	10.04	2.49	4.03
Normal															
DB	LWT														
	5			10			15			20			25		
	CC	PI	EER	CC	PI	EER	CC	PI	EER	CC	PI	EER	CC	PI	EER
-5	/	/	/	/	/	/	5.50	0.49	11.21	7.15	0.58	12.31	7.59	0.55	13.82
0	/	/	/	/	/	/	5.33	0.54	9.79	6.33	0.57	11.14	6.75	0.53	12.66
5	/	/	/	/	/	/	5.11	0.65	7.84	5.41	0.57	9.54	5.88	0.56	10.60
10	/	/	/	/	/	/	5.26	0.55	9.53	6.58	0.58	11.37	7.16	0.64	11.26
15	/	/	/	4.73	0.76	6.24	6.39	0.82	7.80	8.15	0.89	9.18	8.94	0.92	9.74
20	4.83	0.95	5.11	5.82	1.05	5.55	7.23	1.13	6.42	9.29	1.31	7.10	10.87	1.32	8.21
25	5.65	1.26	4.49	6.78	1.38	4.91	8.35	1.50	5.58	10.47	1.66	6.32	12.30	1.71	7.18
30	6.48	1.64	3.95	7.78	1.80	4.32	9.51	1.92	4.95	11.69	2.12	5.51	13.76	2.26	6.08
35	6.31	1.93	3.28	7.78	1.94	4.01	9.09	2.01	4.53	11.08	2.18	5.09	13.23	2.39	5.54
40	5.40	1.92	2.81	6.27	1.86	3.38	7.73	2.04	3.79	9.18	2.06	4.47	11.14	2.28	4.89
43	4.18	1.80	2.32	4.44	1.66	2.67	5.36	1.61	3.32	6.98	1.72	4.06	7.94	1.80	4.41
Minimum															
DB	LWT														
	5			10			15			20			25		
	CC	PI	EER	CC	PI	EER	CC	PI	EER	CC	PI	EER	CC	PI	EER
-5	/	/	/	/	/	/	3.56	0.30	11.68	4.61	0.36	12.69	4.93	0.34	14.49
0	/	/	/	/	/	/	3.46	0.34	10.23	4.09	0.35	11.61	4.39	0.33	13.14
5	/	/	/	/	/	/	2.75	0.33	8.42	2.93	0.29	10.13	3.17	0.28	11.40
10	/	/	/	/	/	/	2.92	0.28	10.33	3.67	0.30	12.18	3.97	0.33	12.22
15	/	/	/	2.90	0.44	6.62	3.42	0.41	8.33	4.08	0.40	10.14	5.11	0.47	10.81
20	2.44	0.46	5.31	2.55	0.44	5.79	3.59	0.53	6.81	5.11	0.68	7.49	6.17	0.71	8.68
25	2.71	0.59	4.60	2.81	0.55	5.15	3.95	0.67	5.88	5.52	0.83	6.64	6.69	0.89	7.54
30	3.08	0.76	4.03	3.19	0.70	4.53	4.45	0.86	5.19	6.10	1.05	5.82	7.41	1.18	6.30
35	2.88	0.85	3.37	3.61	0.86	4.19	4.55	0.94	4.86	5.90	1.07	5.52	7.28	1.23	5.93
40	2.44	0.87	2.80	2.94	0.84	3.48	3.79	0.97	3.93	4.91	1.06	4.64	6.34	1.28	4.97
43	1.43	0.60	2.37	2.12	0.77	2.76	2.80	0.81	3.46	3.55	0.85	4.18	5.06	1.11	4.58

Abbreviations:

LWT: Flow (°C)

DB: Outside temperature (°C)

HC: Heat output (kW)

PI: Power consumption (kW)

14.6 Performance values, cooling LIA 1316HXCF (M)

Maximum															
DB	LWT														
	5			10			15			20			25		
	CC	PI	EER	CC	PI	EER	CC	PI	EER	CC	PI	EER	CC	PI	EER
-5	/	/	/	/	/	/	10.0	1.32	7.57	10.9	1.47	7.44	12.0	1.42	8.43
0	/	/	/	/	/	/	9.80	1.67	5.87	11.4	1.58	7.24	12.5	1.59	7.84
5	/	/	/	/	/	/	9.57	1.76	5.44	12.0	1.61	7.43	13.0	1.68	7.73
10	/	/	/	/	/	/	11.3	2.18	5.21	13.1	1.92	6.85	14.2	1.94	7.32
15	/	/	/	11.0	2.32	4.60	13.1	2.32	5.45	15.5	2.32	6.67	16.4	2.32	7.26
20	8.17	2.17	3.77	12.8	3.16	4.04	14.9	3.33	4.47	15.9	3.14	5.08	16.5	2.84	5.82
25	10.6	3.19	3.32	14.5	3.84	3.77	16.6	4.16	3.99	17.0	4.01	4.24	17.1	3.44	4.96
30	10.5	3.96	2.65	14.1	4.53	3.11	15.9	4.56	3.49	16.2	4.18	3.87	16.1	3.74	4.31
35	10.4	4.81	2.16	13.7	5.32	2.58	15.3	4.88	3.13	15.3	4.44	3.45	15.3	4.12	3.71
40	8.11	4.53	1.79	9.87	4.33	2.28	10.7	3.92	2.72	12.2	4.05	3.01	13.2	3.77	3.51
43	5.20	3.72	1.40	6.11	3.26	1.87	7.33	3.02	2.43	8.53	3.19	2.67	10.7	3.26	3.27
Normal															
DB	LWT														
	5			10			15			20			25		
	CC	PI	EER	CC	PI	EER	CC	PI	EER	CC	PI	EER	CC	PI	EER
-5	/	/	/	/	/	/	8.07	0.94	8.56	8.88	1.03	8.60	9.72	1.01	9.61
0	/	/	/	/	/	/	7.90	1.18	6.71	9.33	1.11	8.39	10.2	1.11	9.13
5	/	/	/	/	/	/	7.67	1.29	5.93	9.61	1.16	8.28	10.6	1.24	8.50
10	/	/	/	/	/	/	9.12	1.60	5.69	10.6	1.38	7.65	11.5	1.43	8.07
15	/	/	/	8.24	1.67	4.94	11.0	1.85	5.92	13.4	1.79	7.48	13.8	1.68	8.19
20	6.37	1.61	3.96	10.3	2.35	4.40	12.4	2.52	4.92	13.7	2.44	5.61	14.4	2.19	6.56
25	8.40	2.39	3.52	11.9	2.89	4.12	14.1	3.23	4.35	14.8	3.14	4.73	15.1	2.65	5.68
30	8.44	2.99	2.82	11.8	3.49	3.37	13.7	3.57	3.83	14.3	3.37	4.25	14.4	2.97	4.86
35	8.07	3.56	2.27	11.3	4.00	2.81	12.6	3.65	3.45	13.4	3.52	3.80	13.9	3.35	4.15
40	6.62	3.45	1.92	8.35	3.35	2.49	9.28	3.09	3.00	10.9	3.24	3.38	12.0	2.97	4.05
43	4.27	2.93	1.45	4.80	2.44	1.97	5.83	2.23	2.61	7.30	2.47	2.96	8.44	2.30	3.66
Minimum															
DB	LWT														
	5			10			15			20			25		
	CC	PI	EER	CC	PI	EER	CC	PI	EER	CC	PI	EER	CC	PI	EER
-5	/	/	/	/	/	/	5.22	0.59	8.92	5.73	0.65	8.86	6.30	0.63	10.08
0	/	/	/	/	/	/	5.13	0.73	7.01	6.04	0.69	8.75	6.61	0.70	9.47
5	/	/	/	/	/	/	4.12	0.65	6.37	5.21	0.59	8.80	5.68	0.62	9.15
10	/	/	/	/	/	/	5.06	0.82	6.16	5.91	0.72	8.20	6.40	0.73	8.75
15	/	/	/	5.05	0.96	5.24	5.88	0.93	6.32	6.68	0.81	8.25	7.86	0.87	9.07
20	3.22	0.78	4.12	4.52	0.99	4.58	6.16	1.18	5.21	7.55	1.28	5.92	8.16	1.18	6.93
25	4.03	1.12	3.60	4.93	1.14	4.32	6.65	1.45	4.58	7.82	1.58	4.96	8.19	1.38	5.95
30	4.01	1.39	2.88	4.82	1.37	3.53	6.41	1.60	4.01	7.47	1.67	4.48	7.77	1.54	5.04
35	3.67	1.58	2.33	5.23	1.78	2.94	6.29	1.70	3.69	7.13	1.73	4.11	7.66	1.73	4.44
40	2.99	1.56	1.91	3.91	1.53	2.56	4.55	1.46	3.11	5.85	1.67	3.50	6.83	1.66	4.12
43	1.46	0.98	1.48	2.30	1.13	2.03	3.05	1.12	2.72	3.72	1.22	3.04	5.38	1.42	3.80

Abbreviations:

LWT: Flow (°C)



DB: Outside temperature (°C)



HC: Heat output (kW)

PI: Power consumption (kW)

15 Product information as per Regulation (EU) No 813/ 2013, Annex II, Table 2

Information requirements for heat pump space heaters and heat pump combination heaters				Glen Dimplex			
Model	Dimplex LIA 0608HXCF M (LIA 0608 M + LIA HX)						
Air-to-water heat pump	yes						
Water-to-water heat pump	no						
Brine-to-water heat pump	no						
Low-temperature heat pump	no						
Equipped with a supplementary heater	yes						
Heat pump combination heater	no						
Parameters shall be declared for medium-temperature application, except for low-temperature heat pumps. For low-temperature heat pumps, parameters shall be declared for low-temperature application.							
Parameters shall be declared for average climate conditions:							
Item	Symbol	Value	Unit	Item	Symbol	Value	Unit
Rated heat output (*)	Prated	5,7	kW	Seasonal space heating energy efficiency	η_s	138	%
Declared capacity for heating foer part load at indoor temperature 20°C and outdoor temperature T_j				Declared coefficient of performance or primary energy ratio for part load at indoor temperature 20 °C and outdoor temperature T_j			
$T_j = -7^\circ\text{C}$	P_{dh}	5,1	kW	$T_j = -7^\circ\text{C}$	COP_d	2,17	-
$T_j = +2^\circ\text{C}$	P_{dh}	3,1	kW	$T_j = +2^\circ\text{C}$	COP_d	3,51	-
$T_j = +7^\circ\text{C}$	P_{dh}	2,1	kW	$T_j = +7^\circ\text{C}$	COP_d	4,54	-
$T_j = +12^\circ\text{C}$	P_{dh}	1,3	kW	$T_j = +12^\circ\text{C}$	COP_d	5,59	-
$T_j = \text{bivalent temperature}$	P_{dh}	5,1	kW	$T_j = \text{bivalent temperature}$	COP_d	2,17	-
$T_j = \text{operation limit temperature}$	P_{dh}	4,5	kW	$T_j = \text{operation limit temperature}$	COP_d	1,91	-
For air-to-water heat pumps				For air-to-water heat pumps:			
$T_j = -15^\circ\text{C}$ (if TOL < -20°C)	P_{dh}	/	kW	$T_j = -15^\circ\text{C}$ (if TOL < -20°C)	COP_d	/	-
Bivalent temperature	T_{biv}	-7	°C	For air-to-water heat pumps:	TOL	-10	°C
Cycling interval capacity for heating	P_{cyc}	-	kW	Operation limit temperature			
Degradation co-efficient (**)	C_{dh}	0,90	-	Cycling interval efficiency	COP_{cyc}	-	-
Power consumption in modes other than active mode				Supplementary heater			
Off mode	P_{OFF}	0,014	kW	Rated heat output (*)	P_{sup}	1,2	kW
Thermostat-off mode	P_{TO}	0,024	kW	Type of energy input	eletrical		
Standby mode	P_{SB}	0,014	kW				
Crankcase heater mode	P_{CK}	0,000	kW				
Other items							
Capacity control	variable			For air-to-water heat pumps: Rated air flow rate, outdoors	-	2770	m ³ /h
Sound power level, indoors/ outdoors	L_{WA}	42/58	dB	For water-/brine-to-water heat pumps: Rated brine or water flow rate, outdoor heat exchanger	-	--	m ³ /h
Emissions of nitrogen oxides	NO_x	-	mg/kWh				
For heat pump combination heater:							
Declared load profile	L			Water heating energy efficiency	η_{wh}	-	%
Daily electricity consumption	Q_{elec}	-	kWh	Daily fuel consumption	Q_{fuel}	-	kWh
Contact details	Glen Dimplex Deutschland GmbH, Am Goldenen Feld 18, 95326 Kulmbach						
(*) For heat pump space heaters and heat pump combination heaters, the rated output P_{rated} is equal to the design load for heating $P_{designh}$, and the rated heat output of a supplementary capacity for heating $sup(T_j)$.							
(**) If C_{dh} is not determined by measurement nthen the default degradation is $C_{dh} = 0,9$							
(–) not applicable							

Information requirements for heat pump space heaters and heat pump combination heaters				 			
Model	Dimplex LIA 0911HXCF M (LIA 0911 M + LIA HX)						
Air-to-water heat pump	yes						
Water-to-water heat pump	no						
Brine-to-water heat pump	no						
Low-temperature heat pump	no						
Equipped with a supplementary heater	yes						
Heat pump combination heater	no						
Parameters shall be declared for medium-temperature application, except for low-temperature heat pumps. For low-temperature heat pumps, parameters shall be declared for low-temperature application.							
Parameters shall be declared for average climate conditions:							
Item	Symbol	Value	Unit	Item	Symbol	Value	Unit
Rated heat output (*)	Prated	7,8	kW	Seasonal space heating energy efficiency	η_s	137	%
Declared capacity for heating foer part load at indoor temperature 20°C and outdoor temperature T_j				Declared coefficient of performance or primary energy ratio for part load at indoor temperature 20 °C and outdoor temperature T_j			
$T_j = -7^\circ\text{C}$	P_{dh}	6,8	kW	$T_j = -7^\circ\text{C}$	COP_d	2,24	-
$T_j = +2^\circ\text{C}$	P_{dh}	4,3	kW	$T_j = +2^\circ\text{C}$	COP_d	3,42	-
$T_j = +7^\circ\text{C}$	P_{dh}	2,8	kW	$T_j = +7^\circ\text{C}$	COP_d	4,52	-
$T_j = +12^\circ\text{C}$	P_{dh}	1,6	kW	$T_j = +12^\circ\text{C}$	COP_d	5,68	-
$T_j = \text{bivalent temperature}$	P_{dh}	6,8	kW	$T_j = \text{bivalent temperature}$	COP_d	2,24	-
$T_j = \text{operation limit temperature}$	P_{dh}	5,4	kW	$T_j = \text{operation limit temperature}$	COP_d	1,83	-
For air-to-water heat pumps				For air-to-water heat pumps:			
$T_j = -15^\circ\text{C}$ (if TOL < -20°C)	P_{dh}	/	kW	$T_j = -15^\circ\text{C}$ (if TOL < -20°C)	COP_d	/	-
Bivalent temperature	T_{biv}	-7	°C	For air-to-water heat pumps:			
				Operation limit temperature	TOL	-10	°C
Cycling interval capacity for heating	P_{cyc}	-	kW	Cycling interval efficiency	COP_{cyc}	-	-
Degradation co-efficient (**)	C_{dh}	0,90	-	Heating water operating limit temperature	WTOL	65	°C
Power consumption in modes other than active mode				Supplementary heater			
Off mode	P_{OFF}	0,014	kW	Rated heat output (*)	P_{sup}	2,3	kW
Thermostat-off mode	P_{TO}	0,024	kW	Type of energy input	eletrical		
Standby mode	P_{SB}	0,014	kW				
Crankcase heater mode	P_{CK}	0,000	kW				
Other items							
Capacity control		variable		For air-to-water heat pumps: Rated air flow rate, outdoors	-	4030	m ³ /h
Sound power level, indoors/ outdoors	L_{WA}	42/60	dB	For water-/brine-to-water heat pumps: Rated brine or water flow rate, outdoor heat exchanger	-	--	m ³ /h
Emissions of nitrogen oxides	NO_x	-	mg/kWh				
For heat pump combination heater:							
Declared load profile		-		Water heating energy efficiency	η_{wh}	-	%
Daily electricity consumption	Q_{elec}	-	kWh	Daily fuel consumption	Q_{fuel}	-	kWh
Contact details	Glen Dimplex Deutschland GmbH, Am Goldenen Feld 18, 95326 Kulmbach						
(*) For heat pump space heaters and heat pump combination heaters, the rated output P_{rated} is equal to the design load for heating $P_{designh}$, and the rated heat output of a supplementary capacity for heating $sup(T_j)$.							
(**) If C_{dh} is not determined by measurement nthen the default degradation is $C_{dh} = 0,9$							
(--) not applicable							

Information requirements for heat pump space heaters and heat pump combination heaters				 			
Model	Dimplex LIA 1316HXCF (LIA 1316 + LIA HX14)						
Air-to-water heat pump	yes						
Water-to-water heat pump	no						
Brine-to-water heat pump	no						
Low-temperature heat pump	no						
Equipped with a supplementary heater	yes						
Heat pump combination heater	no						
Parameters shall be declared for medium-temperature application, except for low-temperature heat pumps. For low-temperature heat pumps, parameters shall be declared for low-temperature application.							
Parameters shall be declared for average climate conditions:							
Item	Symbol	Value	Unit	Item	Symbol	Value	Unit
Rated heat output (*)	Prated	12,1	kW	Seasonal space heating energy efficiency	η_s	137	%
Declared capacity for heating foer part load at indoor temperature 20°C and outdoor temperature T_j				Declared coefficient of performance or primary energy ratio for part load at indoor temperature 20 °C and outdoor temperature T_j			
$T_j = -7^\circ\text{C}$	P_{dh}	10,7	kW	$T_j = -7^\circ\text{C}$	COP_d	2,01	-
$T_j = +2^\circ\text{C}$	P_{dh}	6,9	kW	$T_j = +2^\circ\text{C}$	COP_d	3,42	-
$T_j = +7^\circ\text{C}$	P_{dh}	4,6	kW	$T_j = +7^\circ\text{C}$	COP_d	4,52	-
$T_j = +12^\circ\text{C}$	P_{dh}	3,3	kW	$T_j = +12^\circ\text{C}$	COP_d	6,13	-
$T_j =$ bivalent temperature	P_{dh}	10,7	kW	$T_j =$ bivalent temperature	COP_d	2,01	-
$T_j =$ operation limit temperature	P_{dh}	9,2	kW	$T_j =$ operation limit temperature	COP_d	1,76	-
For air-to-water heat pumps				For air-to-water heat pumps:			
$T_j = -15^\circ\text{C}$ (if TOL < -20°C)	P_{dh}	/	kW	$T_j = -15^\circ\text{C}$ (if TOL < -20°C)	COP_d	/	-
Bivalent temperature	T_{biv}	-7	°C	For air-to-water heat pumps:	TOL	-10	°C
Cycling interval capacity for heating	P_{cyc}	-	kW	Cycling interval efficiency	COP_{cyc}	-	-
Degradation co-efficient (**)	C_{dh}	0,90	-	Heating water operating limit temperature	WTOL	65	°C
Power consumption in modes other than active mode				Supplementary heater			
Off mode	P_{OFF}	0,014	kW	Rated heat output (*)	P_{sup}	2,9	kW
Thermostat-off mode	P_{TO}	0,024	kW	Type of energy input	electrical		
Standby mode	P_{SB}	0,014	kW				
Crankcase heater mode	P_{CK}	0,000	kW				
Other items							
Capacity control	variable			For air-to-water heat pumps: Rated air flow rate, outdoors	-	4060	m ³ /h
Sound power level, indoors/ outdoors	L_{WA}	42/65	dB	For water-/brine-to-water heat pumps: Rated brine or water flow rate, outdoor heat exchanger	-	--	m ³ /h
Emissions of nitrogen oxides	NO_x	-	mg/kWh				
For heat pump combination heater:							
Declared load profile	-			Water heating energy efficiency	η_{wh}	-	%
Daily electricity consumption	Q_{elec}	-	kWh	Daily fuel consumption	Q_{fuel}	-	kWh
Contact details	Glen Dimplex Deutschland GmbH, Am Goldenen Feld 18, 95326 Kulmbach						
(*) For heat pump space heaters and heat pump combination heaters, the rated output P_{rated} is equal to the design load for heating $P_{designh}$, and the rated heat output of a supplementary capacity for heating $sup(T_j)$.							
(**) If C_{dh} is not determined by measurement nthen the default degradation is $C_{dh} = 0,9$							
(-) not applicable							

Information requirements for heat pump space heaters and heat pump combination heaters							
Model	Dimplex LIA 1316HXCF M (LIA 1316 M + LIA HX14)						
Air-to-water heat pump	yes						
Water-to-water heat pump	no						
Brine-to-water heat pump	no						
Low-temperature heat pump	no						
Equipped with a supplementary heater	yes						
Heat pump combination heater	no						
Parameters shall be declared for medium-temperature application, except for low-temperature heat pumps. For low-temperature heat pumps, parameters shall be declared for low-temperature application.							
Parameters shall be declared for average climate conditions:							
Item	Symbol	Value	Unit	Item	Symbol	Value	Unit
Rated heat output (*)	Prated	12,1	kW	Seasonal space heating energy efficiency	η_s	136	%
Declared capacity for heating foer part load at indoor temperature 20°C and outdoor temperature T_j				Declared coefficient of performance or primary energy ratio for part load at indoor temperature 20 °C and outdoor temperature T_j			
$T_j = -7^\circ\text{C}$	P_{dh}	10,7	kW	$T_j = -7^\circ\text{C}$	COP_d	2,01	-
$T_j = +2^\circ\text{C}$	P_{dh}	6,9	kW	$T_j = +2^\circ\text{C}$	COP_d	3,43	-
$T_j = +7^\circ\text{C}$	P_{dh}	4,6	kW	$T_j = +7^\circ\text{C}$	COP_d	4,66	-
$T_j = +12^\circ\text{C}$	P_{dh}	3,3	kW	$T_j = +12^\circ\text{C}$	COP_d	6,13	-
$T_j = \text{bivalent temperature}$	P_{dh}	10,7	kW	$T_j = \text{bivalent temperature}$	COP_d	2,01	-
$T_j = \text{operation limit temperature}$	P_{dh}	9,2	kW	$T_j = \text{operation limit temperature}$	COP_d	1,76	-
For air-to-water heat pumps				For air-to-water heat pumps:			
$T_j = -15^\circ\text{C}$ (if TOL < -20°C)	P_{dh}	/	kW	$T_j = -15^\circ\text{C}$ (if TOL < -20°C)	COP_d	/	-
Bivalent temperature	T_{biv}	-7	$^\circ\text{C}$	For air-to-water heat pumps: Operation limit temperature	TOL	-10	$^\circ\text{C}$
Cycling interval capacity for heating	P_{cyc}	-	kW	Cycling interval efficiency	COP_{cyc}	-	-
Degradation co-efficient (**)	C_{dh}	0,90	-	Heating water operating limit temperature	WTOL	65	$^\circ\text{C}$
Power consumption in modes other than active mode				Supplementary heater			
Off mode	P_{OFF}	0,014	kW	Rated heat output (*)	P_{sup}	2,9	kW
Thermostat-off mode	P_{TO}	0,024	kW	Type of energy input	electrical		
Standby mode	P_{SB}	0,014	kW				
Crankcase heater mode	P_{CK}	0,000	kW				
Other items							
Capacity control		variable		For air-to-water heat pumps: Rated air flow rate, outdoors	-	-	m^3/h
Sound power level, indoors/ outdoors	L_{WA}	42/65	dB	For water-/brine-to-water heat pumps: Rated brine or water flow rate, outdoor heat exchanger	-	--	m^3/h
Emissions of nitrogen oxides	NO_x	-	mg/kWh				
For heat pump combination heater:							
Declared load profile		-		Water heating energy efficiency	η_{wh}	-	%
Daily electricity consumption	Q_{elec}	-	kWh	Daily fuel consumption	Q_{fuel}	-	kWh
Contact details	Glen Dimplex Deutschland GmbH, Am Goldenen Feld 18, 95326 Kulmbach						
(*) For heat pump space heaters and heat pump combination heaters, the rated output $Prated$ is equal to the design load for heating $P_{designh}$, and the rated heat output of a supplementary capacity for heating $sup(T_j)$.							
(**) If C_{dh} is not determined by measurement nthen the default degradation is $C_{dh} = 0,9$							
(-) not applicable							

16 Dimension drawings

16.1 Dimension drawing outdoor unit LIA 0608HXCF M

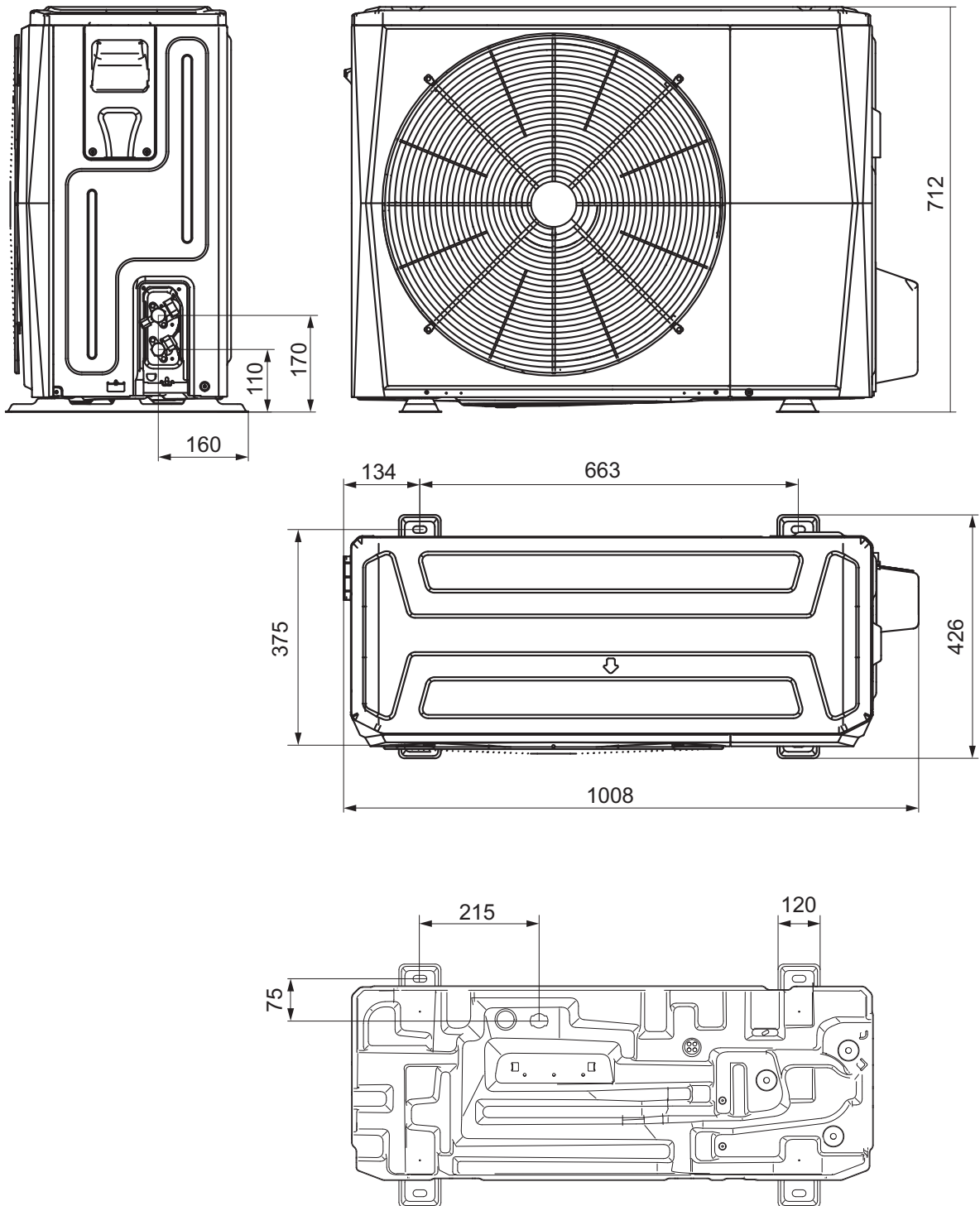

16.2 Dimension drawing outdoor unit LIA 0911HXCF M / LIA 1316HXCF M / LIA 1316HXCF

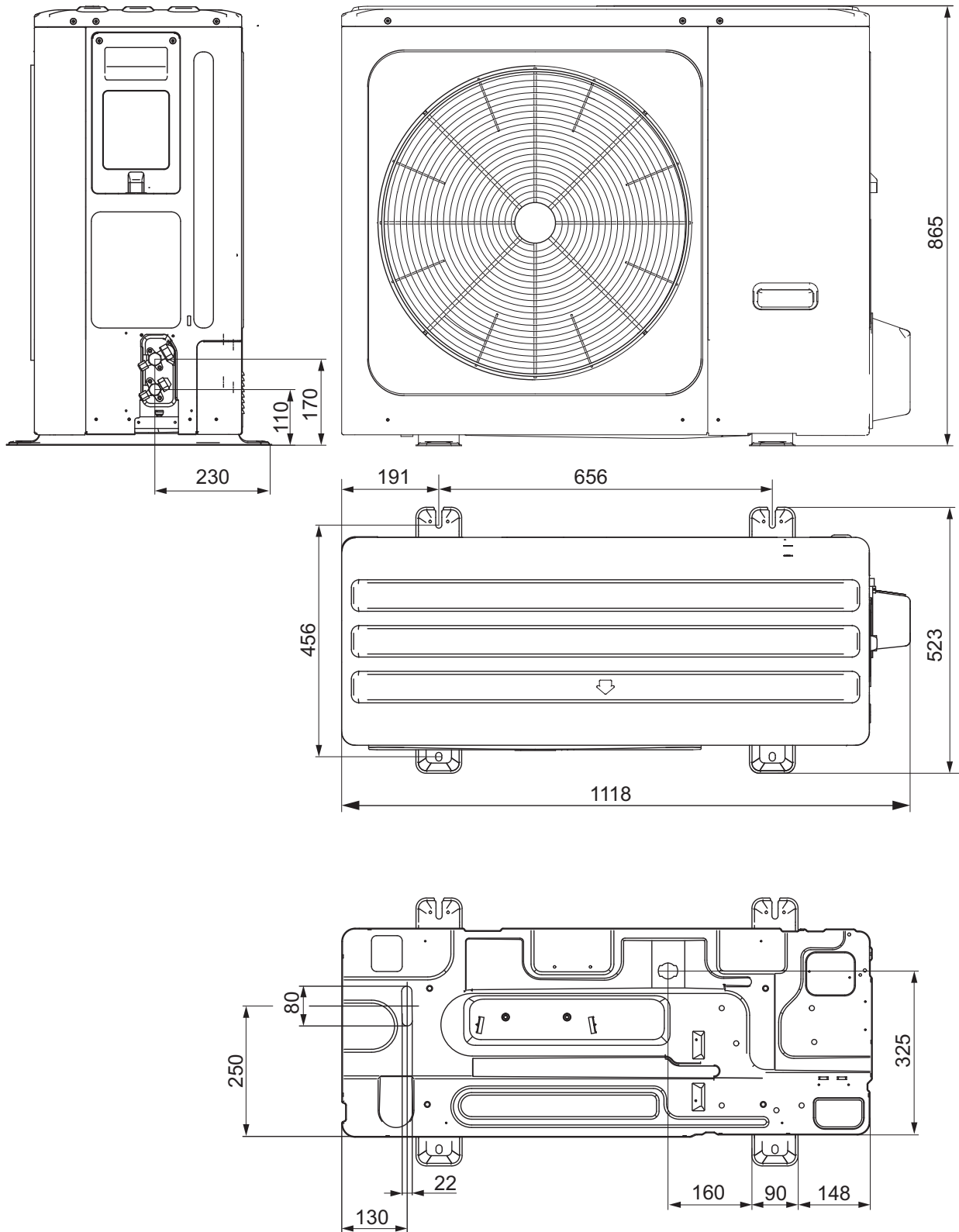

**16.3 Foundation plan
LIA 0608HXCF M**

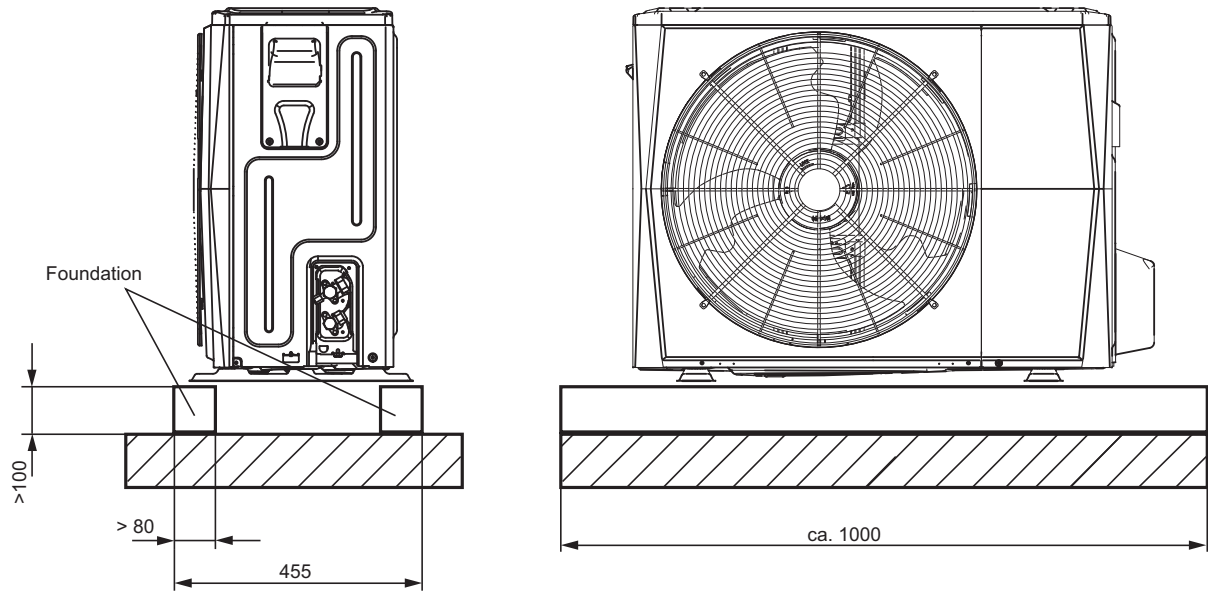

**16.4 Foundation plan
LIA 0911HWCF M /
LIA 1316HXCF M /
LIA 1316HXCF**

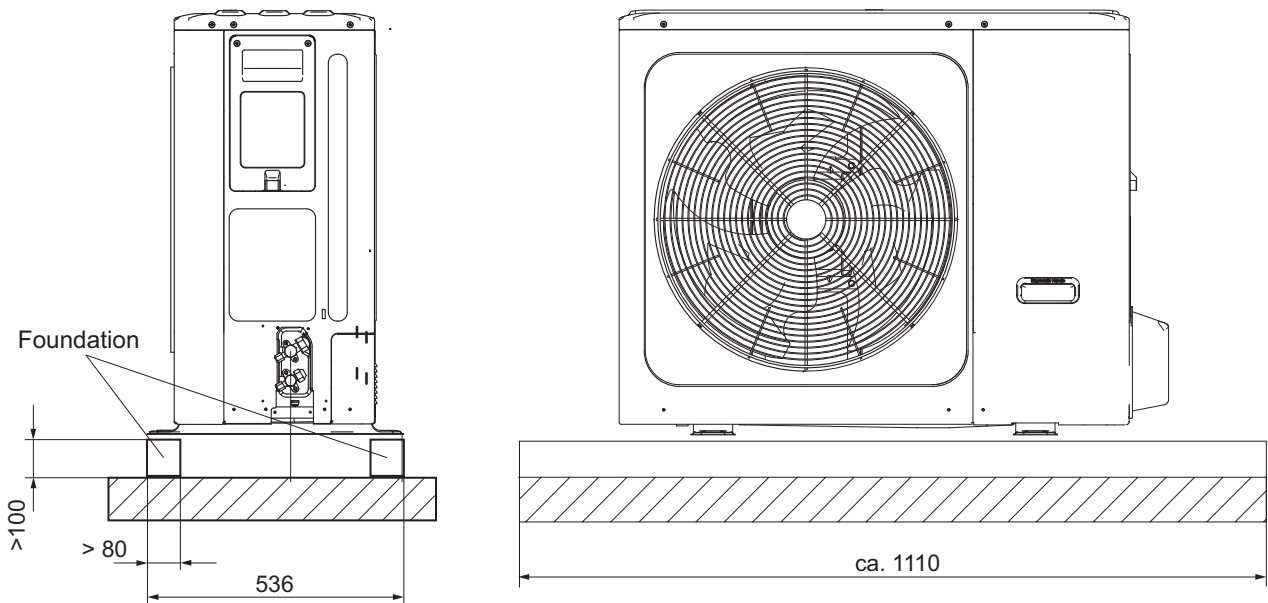

16.5 Dimension drawing indoor unit

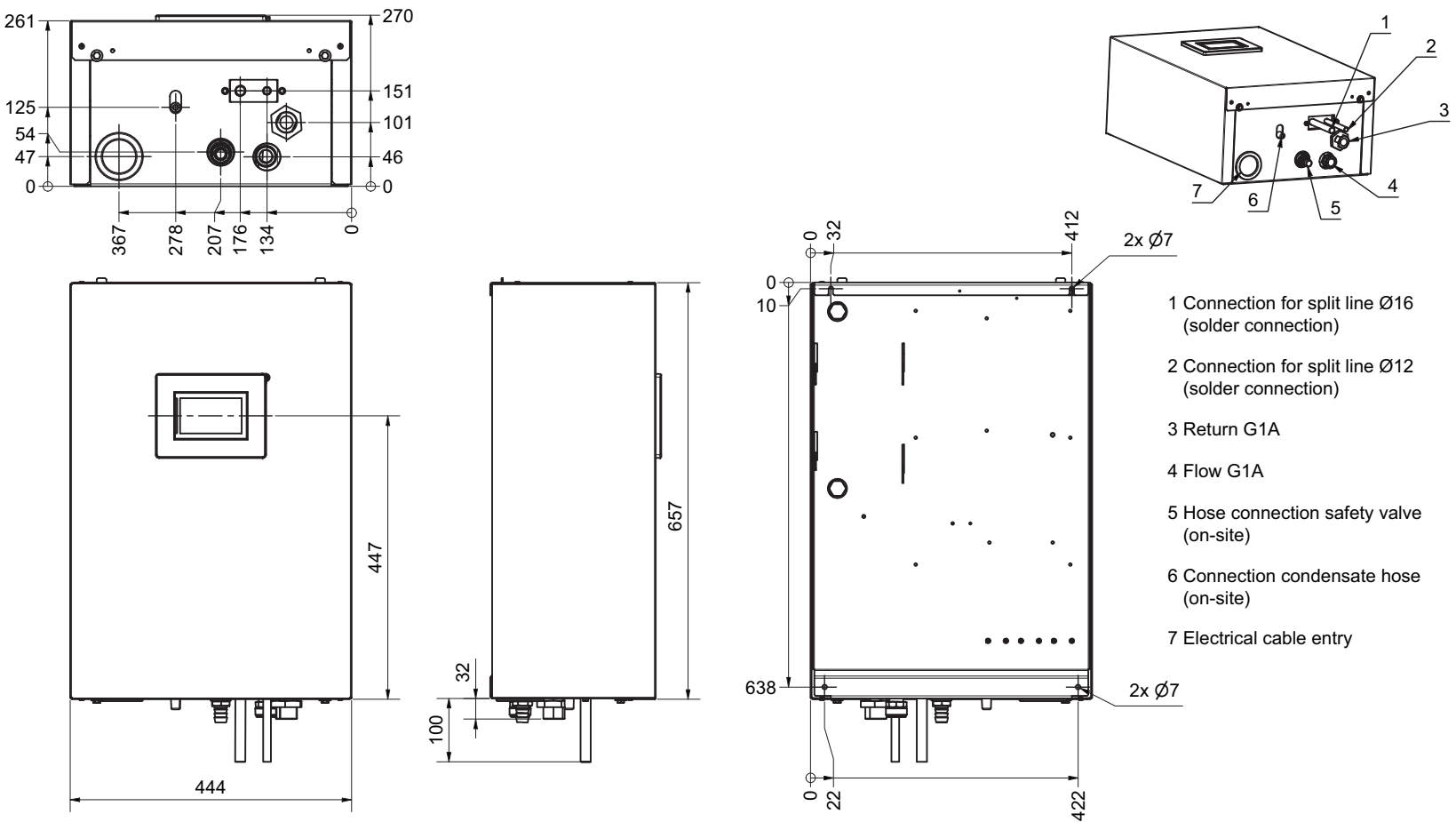

17 Diagrams

17.1 Operating limits diagram heating

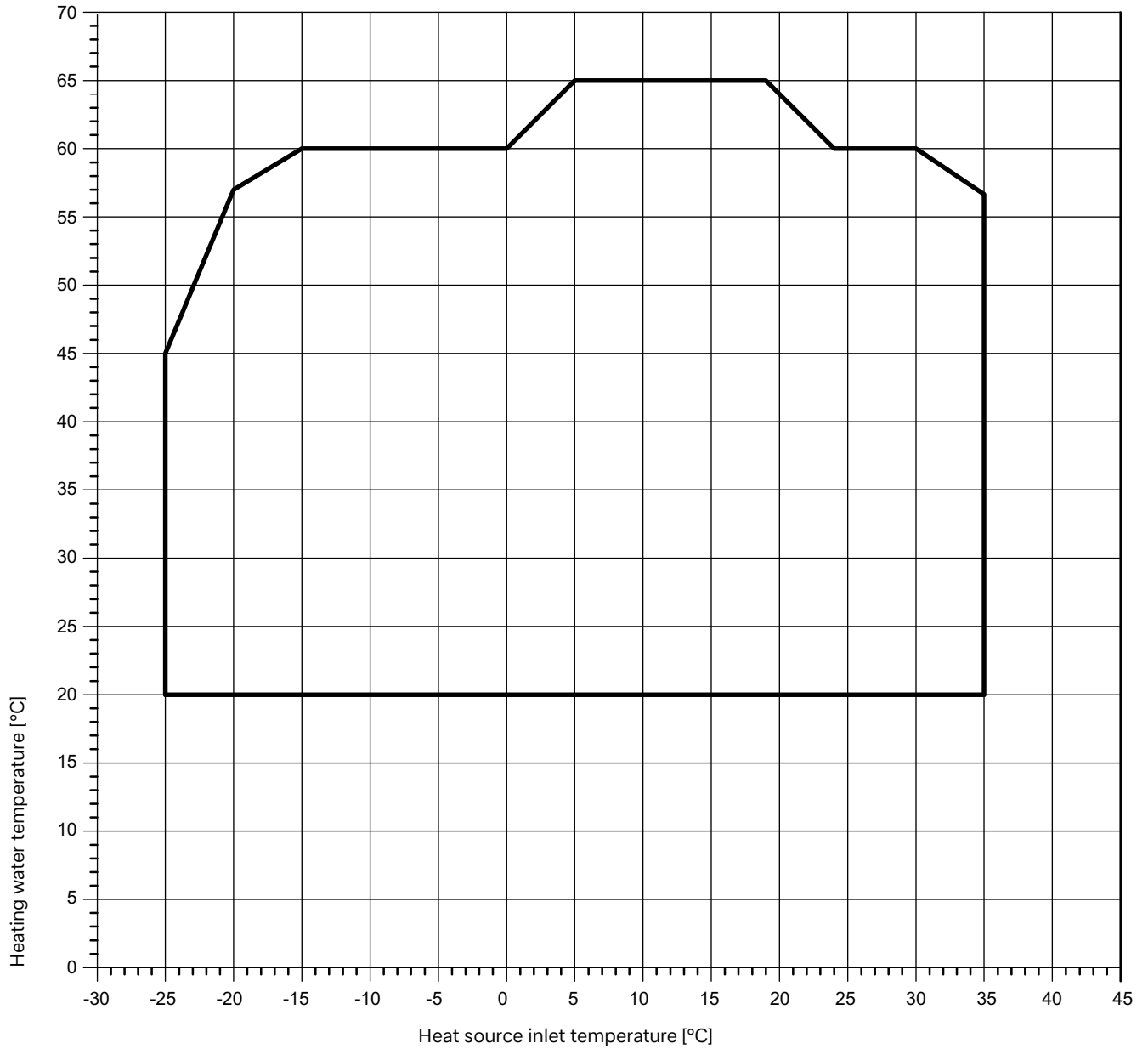

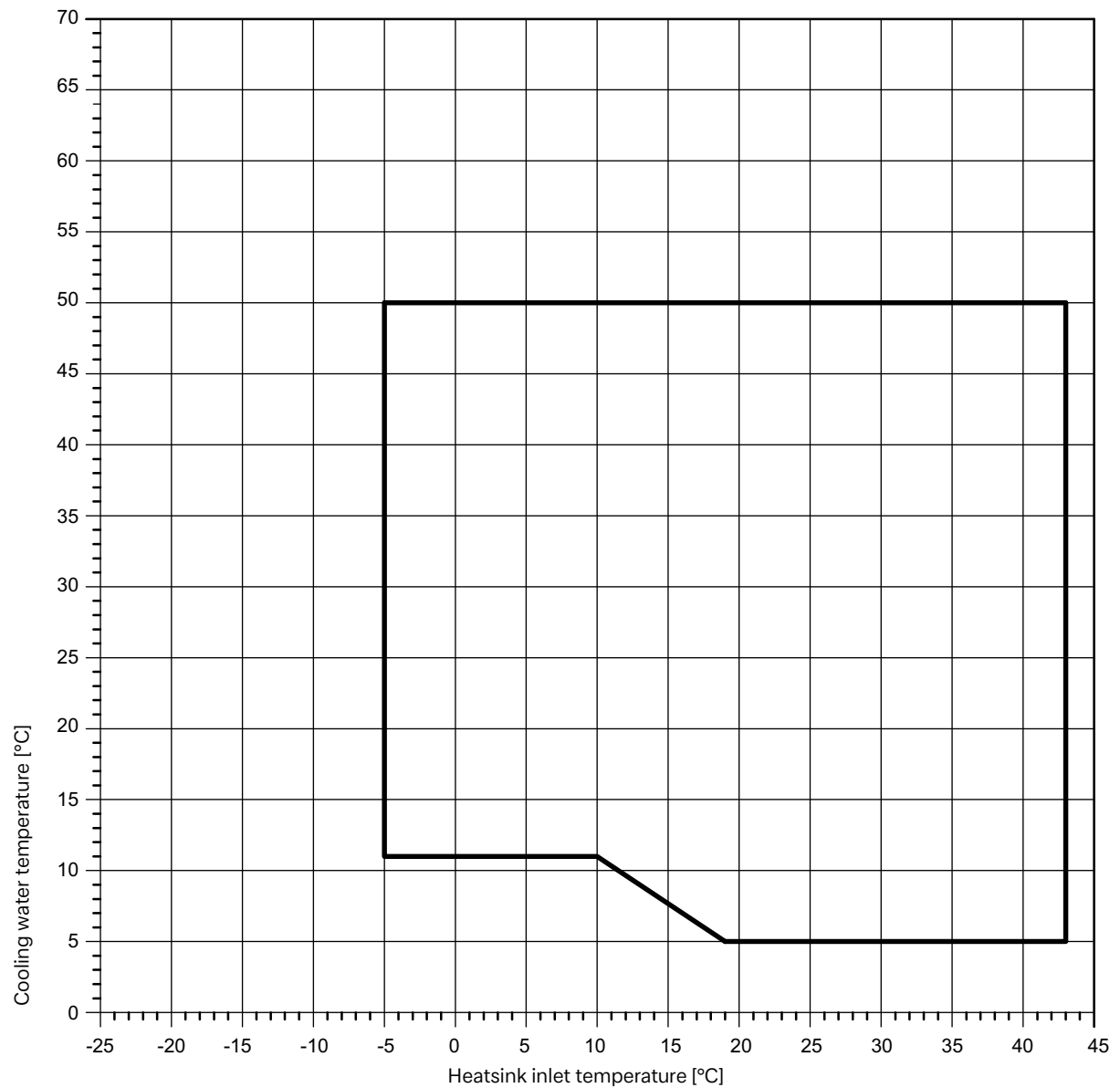

17.2 Operating limits diagram cooling



18 Circuit diagrams

18.1 Circuit diagram LIA 0608HXCF M / LIA 0911HXCF M

FACTORY SETTINGS	S6-1	S6-2	S6-3
6KW 	1	0	0
10KW 	1	1	0

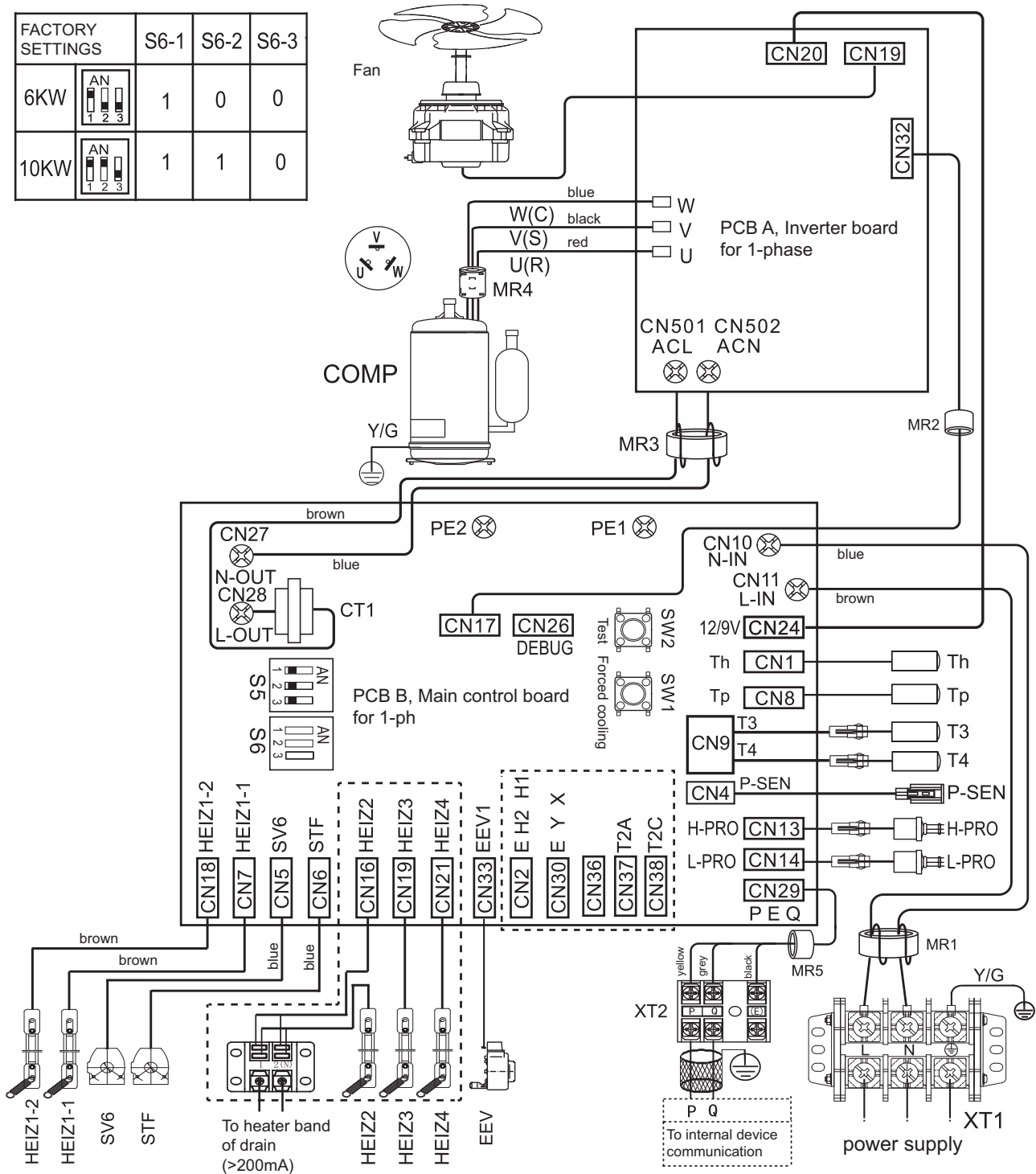

Note: please use a 2-core shielded cable

 The leakage circuit breaker must be installed on the power supply of the device.

18.2 Circuit diagram LIA 1316HXCF M 1-phase

FACTORY SETTINGS	S6-1	S6-2	S6-3
14KW	1	0	1

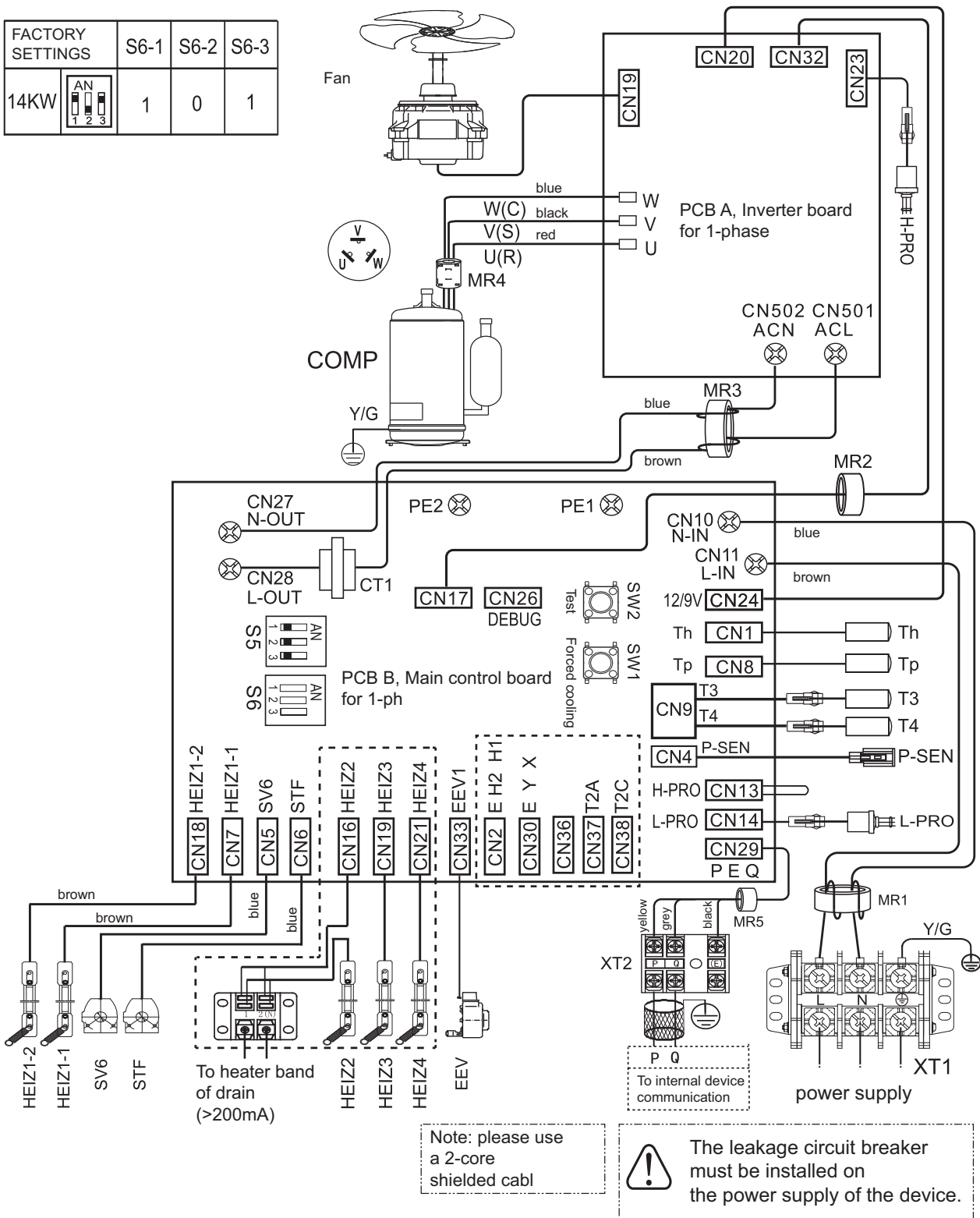

18.3 Circuit diagram LIA 1316HXCF 3-phase

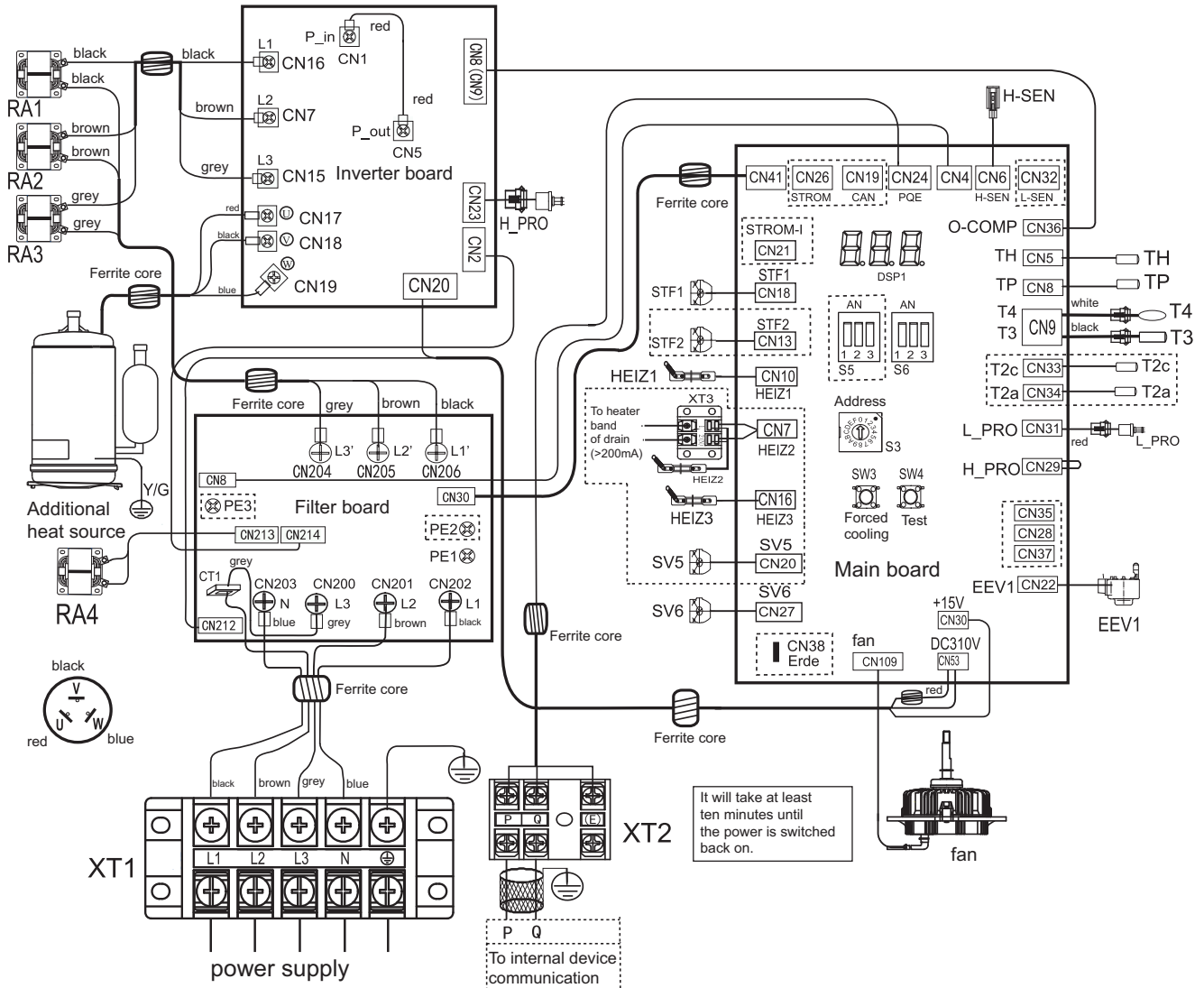

It will take at least ten minutes until the power is switched back on.

Temperature sensor code	Property values
T3/T4/T6(Th)	$B_{25/50} = 4100K$, $R_{25/0} = 10k\Omega$
T5(Tp)	$B_{25/50} = 3950K$, $R_{90/0} = 5k\Omega$

FACTORY SETTINGS	S6-1	S6-2	S6-3
14KW	1	0	0

The circuit diagram is only intended as a reference; the actual product may differ.

! The leakage circuit breaker must be installed on the power supply of the device.
The device must be earthed.

18.4 Legend

PCB A, inverter board for 1-phase

CN19	Connection for fan
CN20	Output connection for +12V/9V
CN32	Connection for communication with PCB B
CN501 ACL	Input connection L for the rectifier bridge
CN502 ACN	Input connection N for the rectifier bridge
U	Compressor U connection
W	Compressor W connection
V	Compressor V connection

PCB B, main control board for 1-phase

CN1	Connection for intake temperature sensor
CN2	Communication connection (reserved)
CN3	Reserve
CN4	Connection for pressure sensor
CN5	Connection for SV6 valve
CN6	Connection for 4-way valve
CN7	Connection for compressor-electric heater band 1
CN8	Connection for outlet temperature sensor
CN9	Connection for outdoor temperature sensor and condenser temperature sensor
CN10	Input connection for the neutral conductor
CN11	Input connection for the live cable
CN13	Connection for high pressure switch
CN14	Connection for low pressure switch
CN16	Connection for electric heater band of the casing (optional)
CN17	Communication connection for PCB A
CN18	Connection for compressor-electric heater band 2
CN19	Reserve
CN20	Reserve
CN21	Reserve
CN22	Reserve
CN24	Input connection for +12V/9V
CN26	Reserve
CN27	Output port N to PCB A
CN28	Output port L to PCB A
CN29	Communication connection for Hydrobox control card
CN30	Communication connection (reserved)
CN33	Connection for electronic expansion valve
CN36	Reserve
CN37	Reserve
CN38	Reserve
PE1	Connection for earthing wire
PE2	Connection for earthing wire

Inverter board for 3-phase

CN1	Input connection P_in for IPM module
CN2	Communication connection for PCB C
CN5	Input connection P_out for IPM module
CN7	Power supply input connection L3
CN8 (CN9)	Input connection N for the rectifier bridge
CN15	Power supply input connection L3
CN16	Power supply input connection L1
CN17	Compressor connection U
CN18	Compressor connection W
CN19	Compressor connection W
CN20	Output connection for +15V
CN22	PED board
CN23	Connection for high pressure switch

Filter board for 3-phase

CN8	Communication connection for PCB
CN30	Power supply connection for main control board
CN200	Power supply L3
CN201	Power supply L2
CN202	Power supply L1
CN203	Power supply N
CN204	Power filtering L3
CN205	Power filtering L2
CN206	Power filtering L1
CN211	Reserved
CN212	Power supply connection of 310VDC
CN213	Connection for fan throttle
CN214	Power supply connection for inverter module
PE1	Connection for earthing wire
PE2	Connection for earthing wire
PE3	Earthing wire

Main control board for 3-phase

CN4	Communication connection for PCB C
CN5	Connection for room temperature sensor Th
CN6	Connection for pressure sensor
CN7	Connection for electric heater band 2
CN8	Connection for temperature sensor Tp
CN9	Connection for outdoor temperature sensor and condenser temperature sensor
CN10	Connection for electric heater band 1
CN11	Reserved
CN13	
CN16	
CN18	Connection, 4-way valve
CN19	
CN20	Connection for 2-way valve 5
CN21	Reserved
CN22	Connection for electric expansion valve
CN24	Communication connection for Hydrobox control card

CN26	Communication connection for power meter
CN27	Connection for 2-way valve 6
CN28	Communication connection for XYE
CN29	Connection for low pressure switch and quick check
CN30	Connection for fan 15 VDC power supply
CN31	Connection for low pressure switch
CN32	
CN33	
CN34	
CN35	Connection for temperature sensor (TW_out, TW_in; T1, T2, T2B)
CN36	Communication connection for PCB A
CN37	Communication connection for H1H2E
CN38	Connection for earthing wire
CN41	Power supply connection for PCB C
CN53	Connection for fan 310 VDC power supply
CN109	Connection for fan



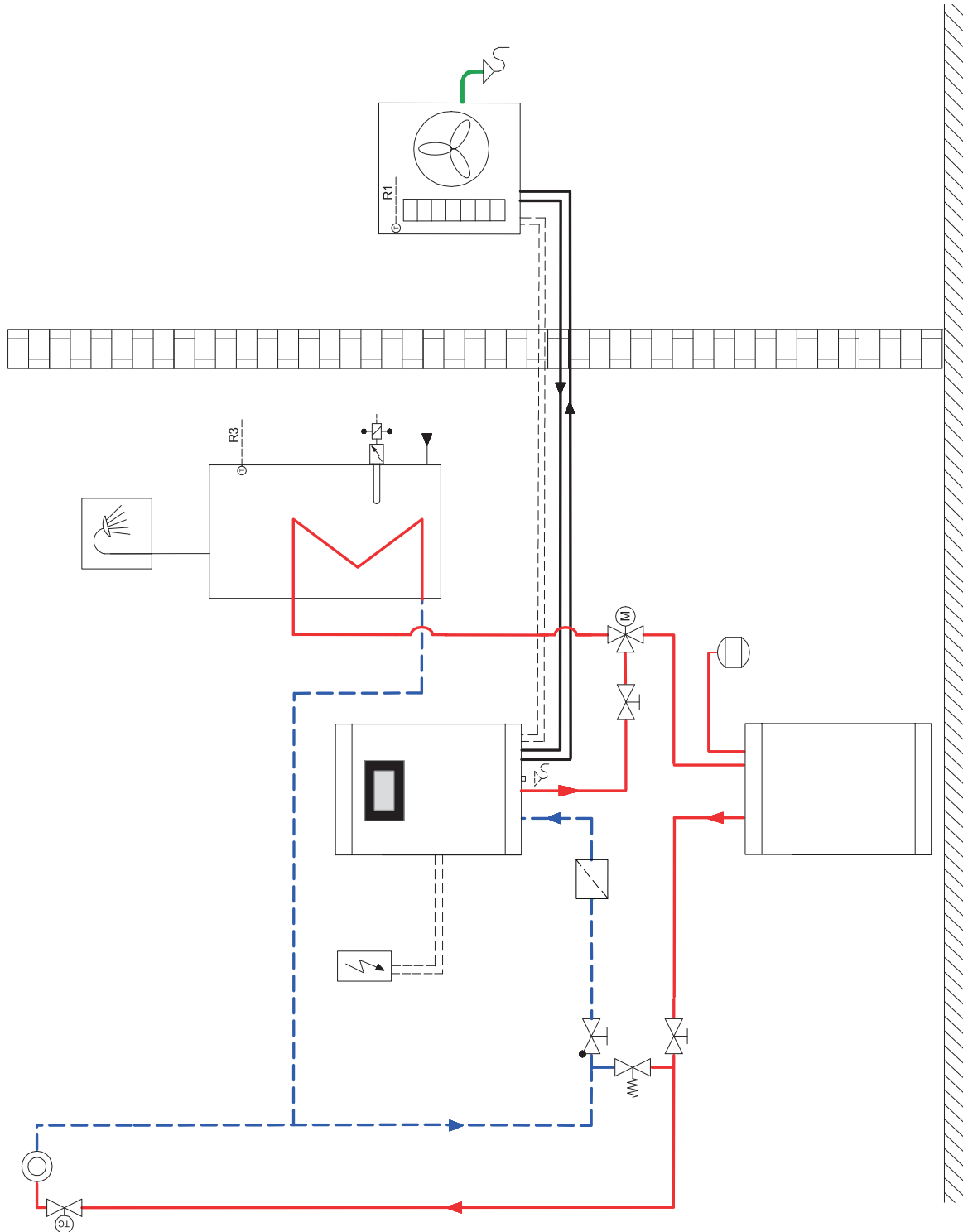











19.2 Mono energy system with one heating circuit and domestic hot water preparation



i NOTE

The hydraulic integration diagram is an example and intended only as an aid. The system requires professional and safety-approved layout by a specialist planner. All information in the section on installation and the corresponding safety notes must be observed at all times.

19.3 Legend

	Isolating valve
	Overflow valve
	Check valve
	Circulating pump
	Room-temperature controlled valve
	Isolating valve with check valve
	Heat consumer
	Temperature sensor
	Three-way mixer
	Dirt trap
	Outdoor unit
	Indoor unit
	Buffer tank
	Domestic hot water cylinder
R1	External sensor
R3	Temperature sensor, domestic hot water

20 Declaration of conformity

You can find the current CE declaration of conformity to download

<https://dimplex.de/lia0608hxcfm>

<https://dimplex.de/lia0911hxcfm>

<https://dimplex.de/lia1316hxcf>

<https://dimplex.de/lia1316hxcfm>



Glen Dimplex Deutschland

Head office

Glen Dimplex Deutschland GmbH
Am Goldenen Feld 18
D-95326 Kulmbach

T +49 9221 709-101
F +49 9221 709-339
info@dimplex.de
www.dimplex.de

On site service

After-sales service, technical support and spare parts. Assistance before and after installation of your equipment

T +49 9221 709-545
F +49 9221 709-924545
Mon - Thu: 7:00 to 17:00
Fri: 7:00 to 15:00
service@dimplex.de

Request after-sales service on the internet:
www.dimplex.de/dimplex-service