

LI 1422C

LI 1826C

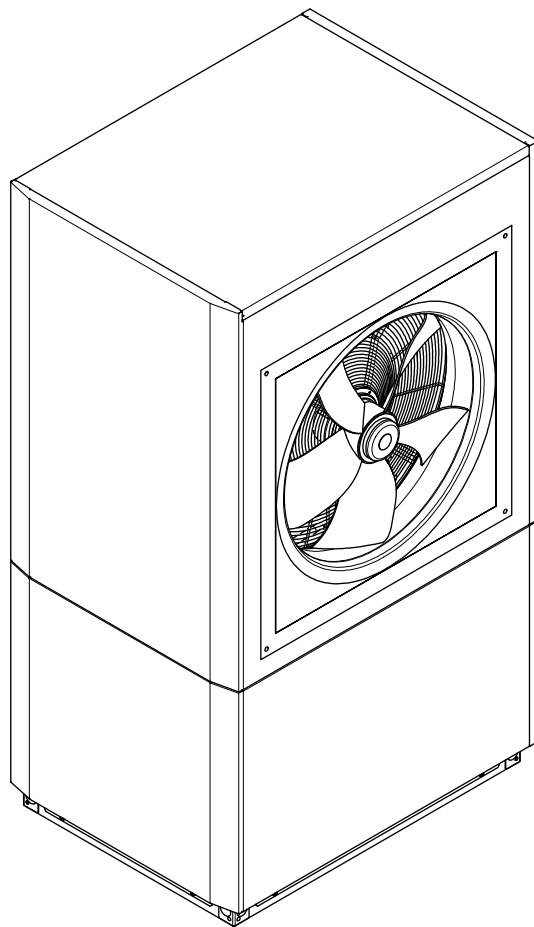

Installation and Operating Instruction

Air-to-Water
Heat Pump for
Indoor Installation

Table of contents

1	Safety notes	EN-2
1.1	Symbols and markings.....	EN-2
1.2	General safety information.....	EN-2
1.3	Intended use.....	EN-3
1.4	Legal regulations and directives.....	EN-3
1.5	Energy-efficient use of the heat pump.....	EN-3
2	Intended use of the heat pump	EN-4
2.1	Area of application.....	EN-4
2.2	Operating principle.....	EN-4
2.3	Functional description for integrated thermal energy metering.....	EN-4
3	Scope of supply	EN-5
3.1	Basic device.....	EN-5
3.2	Switch box.....	EN-5
3.3	Heat pump manager.....	EN-5
4	Transport	EN-6
5	Installation	EN-8
5.1	General.....	EN-8
5.2	Condensate pipe.....	EN-8
5.3	Sound.....	EN-8
6	Assembly	EN-9
6.1	General.....	EN-9
6.2	Air connection.....	EN-9
6.3	Connection on heating side.....	EN-10
6.4	Water Quality in Heating Systems.....	EN-10
6.5	Electrical connection.....	EN-12
7	Commissioning	EN-13
7.1	General.....	EN-13
7.2	Preparation.....	EN-13
7.3	Procedure.....	EN-14
8	Cleaning / maintenance	EN-14
8.1	Care.....	EN-14
8.2	Cleaning the heating system.....	EN-15
8.3	Cleaning the air system.....	EN-15
9	Faults / troubleshooting	EN-15
10	Decommissioning/disposal	EN-15
11	Device information	EN-16
12	Product information as per Regulation (EU) No 813/2013, Annex II, Table 2	EN-18
13	Dimension Drawings	EN-20
13.1	Dimension Drawing.....	EN-20
14	Diagrams	EN-21
14.1	Characteristic curves for heating operation LI 1422C.....	EN-21
14.2	Characteristic curves for cooling operation LI 1422C.....	EN-22
14.3	Characteristic curves for heating operation LI 1826C.....	EN-23
14.4	Characteristic curves for cooling operation LI 1826C.....	EN-24
14.5	Operating limits diagram heating.....	EN-25
14.6	Operating limits diagram cooling LI 1422C.....	EN-26
14.7	Operating limits diagram cooling LI 1826C.....	EN-27
15	Integration diagram	EN-28
15.1	Hydraulic integration diagrams.....	EN-28
15.2	Hydraulic integration diagrams.....	EN-29
15.3	Legend.....	EN-30
16	Declaration of Conformity	EN-31

1 Safety notes

1.1 Symbols and markings

Particularly important information in these instructions is marked with CAUTION! and NOTE.

⚠ CAUTION!

Immediate danger to life or danger of severe personal injury or significant damage to property.

i NOTE

Risk of damage to property or minor personal injury or important information with no further risk of personal injury or damage to property.

1.2 General safety information

The following warnings and safety notes must be observed in all life phases of the device:

⚠ CAUTION!

Work on the heat pump must only be performed by authorised and qualified after-sales service technicians!

⚠ CAUTION!

Failure to use personal protective equipment could result in severe injury. Risk of injury!

- ▶ Use of personal protective equipment (PPE) in accordance with DGUV regulation 100-500 Chap. 2.35
- ▶ Personal protective equipment consisting of safety gloves, safety shoes, safety glasses and long, closed clothing must be used.

⚠ CAUTION!

There is a risk of falling or slipping on trip hazards and leaking operating materials. Risk of injury!

- ▶ Trip hazards caused by cables, pipes and hoses must be avoided.
- ▶ Operating material leaks must be absorbed with suitable binding agents and disposed of in accordance with the hazard class.

⚠ CAUTION!

Before opening the device, ensure that all circuits are powered down.

⚠ CAUTION!

Failure to observe the safety rules could result in electric shock. Danger to life!

- ▶ National and regional regulations on accident prevention and carrying out electrical installations must be observed.
- ▶ The five safety rules must be applied when carrying out electrical installations:
 - Disconnect,
 - Secure against being switched on again,
 - Ensure that there is an absence of voltage at all poles.
 - Earth and short circuit,
 - Cover or cordon off neighbouring live parts. After disconnecting the power supply, you have to wait 5 minutes before all components are de-energised.

⚠ CAUTION!

It is forbidden to operate the heat pump without safety devices (cover, grating).

⚠ CAUTION!

Please refrain from tampering with or altering the device.

1.3 Intended use

This device is only intended for use as specified by the manufacturer. Any other use beyond that intended by the manufacturer is prohibited. This requires the user to abide by the relevant project planning documents.

1.4 Legal regulations and directives

This heat pump is designed for use in a domestic environment according to Article 1, Paragraph 2 k) of EU directive 2006/42/EC (Machinery Directive) and is thus subject to the requirements of EU directive 2014/35/EU (Low Voltage Directive). It is thus also intended for use by non-professionals for heating shops, offices and other similar working environments, agricultural establishments and hotels, guest houses and other residential buildings.

The construction and design of the heat pump complies with all relevant EU directives, and DIN/VDE regulations (see CE declaration of conformity).

When connecting the heat pump to the power supply, the relevant VDE, EN and IEC standards are to be adhered to. Any further connection requirements stipulated by local utility companies must also be observed.

When connecting the heating system, all applicable regulations must also be adhered to.

This unit can be used by children aged 8 and over and by persons with limited physical, sensory or mental aptitude or lack of experience and/or knowledge, providing they are supervised or have been instructed in safe use of the unit and understand the associated potential dangers.

Children must not play with the device. Cleaning and user maintenance must not be carried out by children without supervision.

i NOTE

When operating or maintaining a heat pump, the legal requirements of the country where the heat pump is operated apply. Depending on the refrigerant fill quantity, the heat pump must be inspected for leaks at regular intervals by a certified technician, and these inspections must be recorded.

More information can be found in the accompanying log book.

1.5 Energy-efficient use of the heat pump

With the purchase of this heat pump, you are helping to protect the environment. A prerequisite for energy-efficient operation is the correct design of the heat source system and heating system.

To maintain heat pump efficiency, it is particularly important to keep the temperature difference between the heating water and heat source to a minimum. For this reason, it is advisable to design the heat source and heating system very carefully. **A temperature difference of approx. 1 Kelvin (1 °C) increases the power consumption by around 2.5 %.** When designing the heating system, it should be borne in mind that special consumers such as domestic hot water preparation should also be taken into consideration and dimensioned for low temperatures. **Underfloor heating systems (panel heating)** are optimally suited for heat pump use on account of the low flow temperatures (30 °C to 40 °C).

It is important to ensure that the heat exchangers are not contaminated during operation, as this increases the temperature difference, which in turn reduces the coefficient of performance (COP).

When set correctly, the heat pump manager is also an essential factor in the energy-efficient use of the heat pump. Further information can be found in the heat pump manager operating instructions.

2 Intended use of the heat pump

2.1 Area of application

The air-to-water heat pump is to be used exclusively for the heating and cooling of heating water. It can be used in new or existing heating systems.

The heat pump is suitable for mono energy and bivalent operation in outside air temperatures to -22 °C.

Proper defrosting of the evaporator is guaranteed by maintaining a heating water return temperature of more than 22 °C (+2 °C/-0 °C) during continuous operation.

The heat pump is not designed for the increased heat consumption required when a building is being dried out. For this reason, the additional heat consumption should be met using special devices provided by the customer. If a building is to be dried out in autumn or winter, we recommend installing an additional electric heating element (available as an accessory).

In cooling operation, the heat pump is suitable for air temperatures ranging from +15 °C to + 45 °C. It can be used for silent and dynamic cooling. The minimum cooling water inlet temperature see "Device information" on page 16.

i NOTE

The device is not suitable for operation with a frequency converter.

2.2 Operating principle

Heat

Outside air is drawn in by the ventilator and fed via the evaporator (heat exchanger). The evaporator cools the air, i.e. extracts heat from it. This extracted heat is then transferred to the working medium (refrigerant) in the evaporator.

The heat is "pumped" to a higher temperature level by increasing its pressure with the aid of the electrically driven compressors. It is then transferred to the heating water via the liquefier (heat exchanger).

Electrical energy is used to raise the temperature level of the heat from the environment. Since the energy extracted from the air is transferred to the heating water, this type of device is referred to as an air-to-water heat pump.

Main components of the air-to-water heat pump are the evaporator, fan, expansion valve, 4-way reversing valve, as well as the compressor, the liquefier and the electrical control system.

At low ambient temperatures, humidity accumulates on the evaporator in the form of frost, reducing the transfer of heat. Uneven accumulation during this process does not indicate a fault. The evaporator is defrosted automatically by the heat pump as required. Under certain atmospheric conditions, steam may be emitted from the air outlet.

Cooling

The functions of the evaporator and the liquefier are reversed in the "Cooling" operating mode.

The heating water transfers its heat to the refrigerant via the liquefier, which is now functioning as an evaporator. The refrigerant is brought to a higher temperature level using the compressor. Heat is transferred to the surrounding air via the liquefier (which, in heating operation, functions as an evaporator).

2.3 Functional description for integrated thermal energy metering.

The compressor manufacturer's performance specifications for different pressure levels are stored in the heat pump software. Two additional pressure sensors for determining the current pressure level are installed in the refrigerating circuit, one before and one after the compressor. The current heat output can be calculated from the compressor data stored in the software and the current pressure level. The integral for the heat output over the runtime gives the quantity of thermal energy supplied by the heat pump, which is displayed separately for heating, domestic hot water preparation and swimming pool water preparation on the heat pump manager display.

The integrated thermal energy metering must not be used for heating cost billing purposes. EN 1434 is not applicable.

3 Scope of supply

3.1 Basic device

The heat pump contains the components listed below.

The refrigeration circuit is "hermetically sealed" and contains the fluorinated refrigerant R410A incorporated in the Kyoto protocol. Information on the GWP value and CO₂ equivalent of the refrigerant is available under "Device information". The refrigerant is CFC-free, non-ozone depleting and non-combustible.

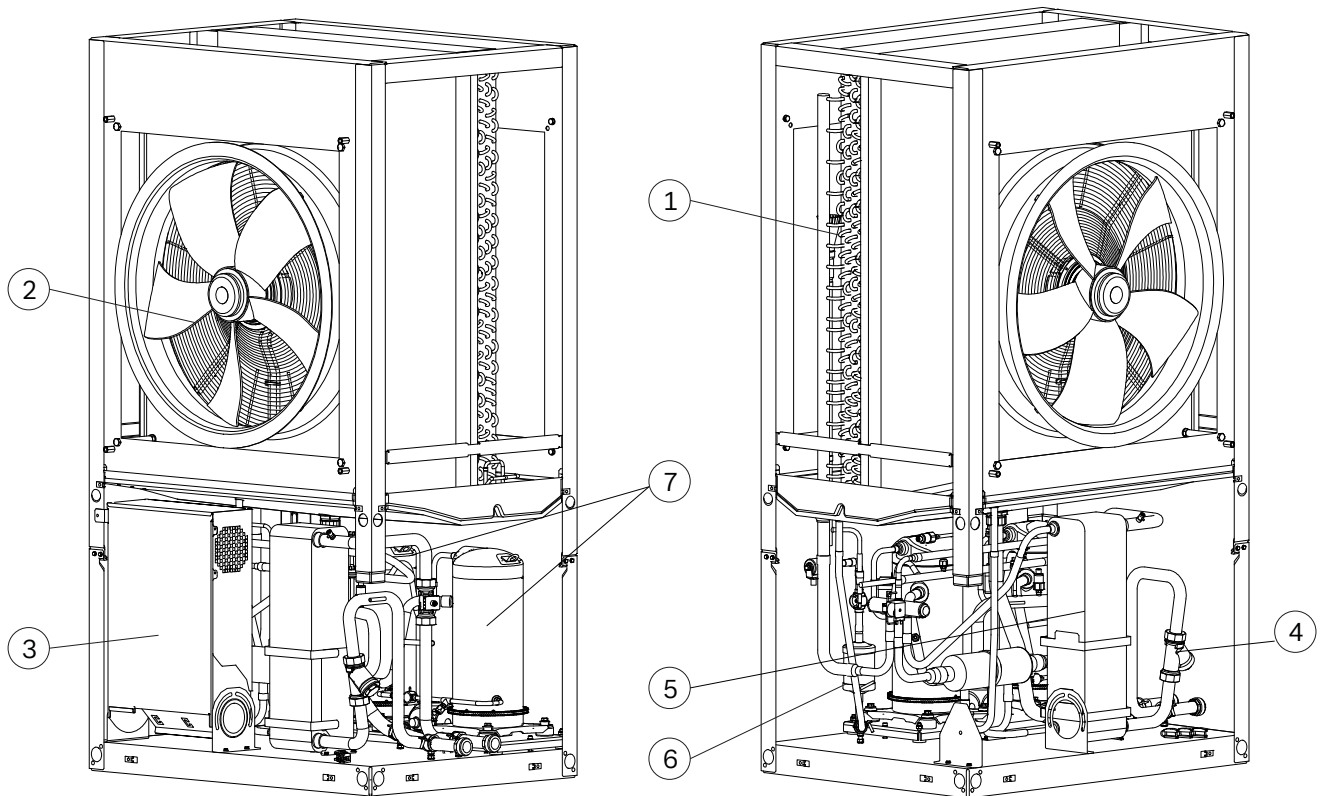

- 1) Evaporators
- 2) Fan
- 3) Switch box
- 4) Dirt trap
- 5) Liquefier
- 6) Filter dryer
- 7) Compressor

3.2 Switch box

The switch box located in the device can be folded out once the bottom front cover has been removed and the fixing screw has been loosened.

The power supply terminals, power contactors, the soft starter units and the extended controller unit (refrigeration circuit control) are inside the switch box. The refrigeration circuit control monitors and controls all heat pump signals and communicates with the heat pump manager.

Communication and control or mains cables, which should be routed apart from each other, are fed into the switch box through the cable entry area on the side plate.

3.3 Heat pump manager

The heat pump manager included in the scope of supply must be used to operate the air-to-water heat pump.

The heat pump manager is a convenient electronic regulation and control device. It controls and monitors the entire heating system based on the outside temperature, as well as domestic hot water preparation and safety systems.

Sensors for heating demand and outside temperature to be installed on site, including mounting material, are included with the heat pump manager.

The functions and usage of the heat pump manager are described in the operating instructions supplied with it.

4 Transport

⚠ CAUTION!

Risk of injury when lifting and setting down the load. Risk of crushing!

- ▶ Do not stand under the load when lifting and setting down.

⚠ CAUTION!

Risk of injury if unsuitable lifting devices are used incorrectly. Risk of falling and crushing!

- ▶ People may only stand outside the danger area. (Germany: DGUV regulation 100-500 Chap. 2.3)
- ▶ Observe the load capacity of the lifting devices and slings used. (Germany: DGUV regulation 100-500 Chap. 2.8)

⚠ CAUTION!

Risk of the heat pump tipping over if unsuitable attachment points are used. Risk of falling and crushing!

- ▶ The heat pump may only be lifted from the operator side with a lift truck or forklift.

⚠ CAUTION!

Work may only be carried out on the device outdoors in dry weather conditions. Risk of damage to the device or electric shock!

- ▶ In wet weather conditions such as rain, snow etc., the housing of the heat pump must be kept properly closed

⚠ CAUTION!

Do not stand near the device during storms. Risk of lightning!

- ▶ Do not stand in the immediate vicinity of the heat pump.

⚠ CAUTION!

Weather-related conditions on transport routes. Risk of injury due to slipping!

- ▶ Transport routes must be kept clear and weather-related conditions such as ice and snow must not impair safe transport.

⚠ CAUTION!

The heat pump must not be tipped during transport. The machine must be secured to prevent the risk of tipping.

A pallet should be used to transport the heat pump to its final installation location. The basic device can be transported with a lift truck, hand truck or by means of 3/4" pipes fed through the holes in the baseplate or frame.

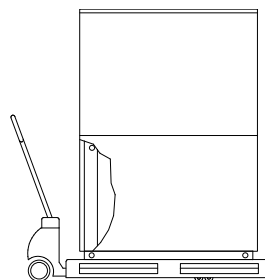

Before using the transport holes in the frame, it is necessary to remove the lower side panel assemblies. This is done by loosening each of the two screws at the base and then withdrawing the panels by unhooking them from above. Rehang the panels by gently pushing them in an upwards direction.

Be careful not to damage any components when inserting the pipes through the frame.

Any transport holes are to be covered at the installation location using the 8 black dust caps, which are included in the device's accessories pack.

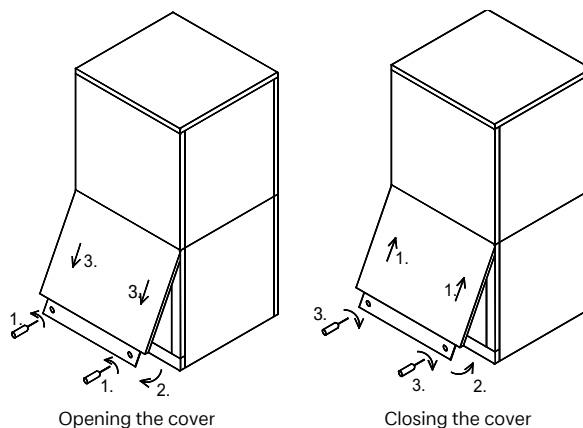

After transportation, the transport fastening in the device is to be removed from both sides of the base.

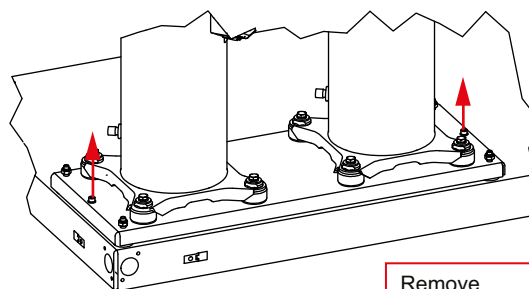

Remove
(2 screw)
transport lock

i NOTE

Before commissioning, the transport fastening must be removed.

For easier transportation into existing homes/buildings, it is possible to separate the basic device into two parts.

Once the covering panels have been removed, please proceed as follows:

- 1) Drain refrigerant
- 2) Remove condensate hose
- 3) Loosen the switch box from the frame
- 4) Remove the pipe insulation above the soldering points
- 5) Separate 4x soldering points chip-free.
- 6) Disconnect the fan cable in the switch box
- 7) Unfasten 4x screws in the corners in each case
- 8) Lift down the top part of the heat pump
- 9) Areas for lifting on the frame
- 10) Transport heat pump to the installation location
- 11) Join the parts
- 12) Re-solder the separation points again (with inert gas flushing)
- 13) Evacuate the refrigeration circuit
- 14) Add refrigerant
- 15) Perform leakage tightness test
- 16) Re-attach pipe insulation
- 17) Re-connect fan
- 18) Bores for attaching a transport aid (e.g. lifting straps etc.)
- 19) Remove the transport locks on the base on both sides before commissioning

i NOTE

Do not lift by the condensate tray. This cannot withstand any forces.

i NOTE

The condensate hose must be removed before the upper part is put down.

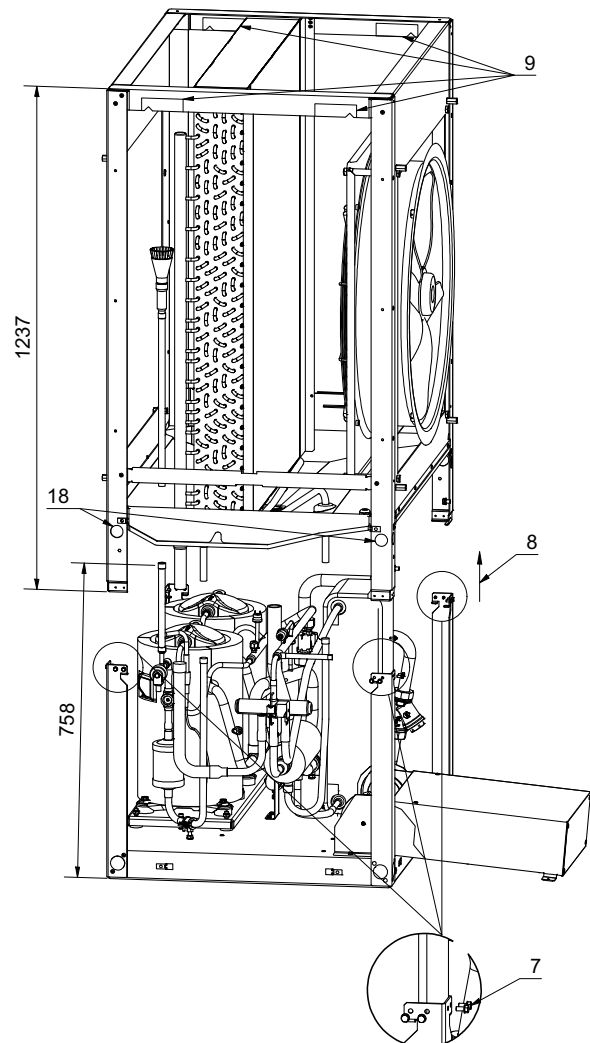
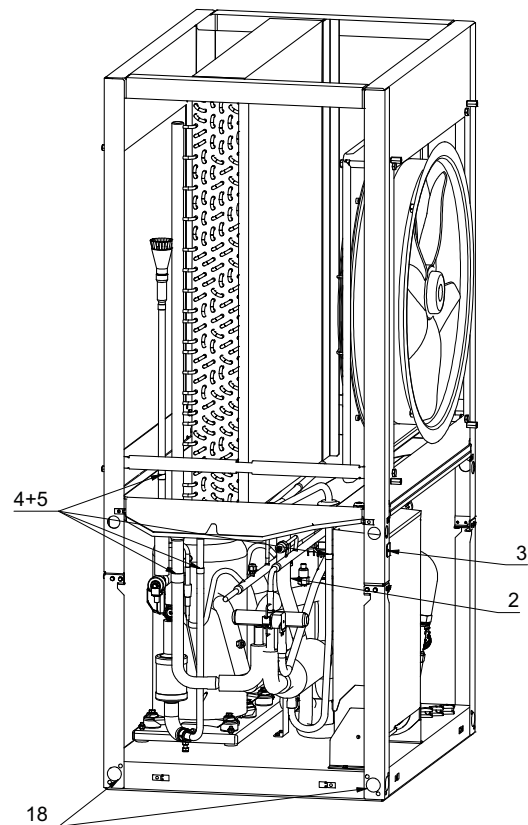

5 Installation

5.1 General

The air-to-water heat pump must be installed in a frost-free, dry room on an even, smooth and horizontal surface. The entire base of the frame should lie directly on the floor to ensure an adequate soundproof seal. If this is not the case, additional sound insulation measures may be necessary. The heat pump must be installed in a way that allows maintenance work to be carried out without hindrance. This is ensured when observing the distances to solid walls as shown in the figure.

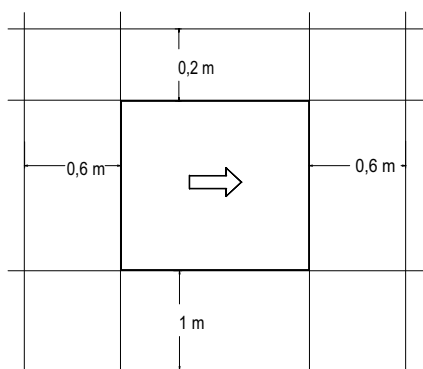

i NOTE

The heat pump is not intended for use above 2000 metres (mean sea level).

Never install the device in rooms subject to high humidity. Condensation can form on the heat pump and air circuit if the humidity exceeds 50 % and the external temperature is below 0 °C.

Neither frost nor temperatures higher than 35 °C must occur in the installation room at any time of the year.

If the heat pump is installed on an upper storey, the load-bearing capacity of the ceiling should be checked. On account of the acoustics, measures for isolating possible vibrations should also be very carefully planned in advance as well. Installation on floors above wooden ceilings is not recommended.

5.2 Condensate pipe

Condensate that forms during operation must be drained off frost free. To ensure proper drainage, the heat pump must be mounted horizontally. The condensate pipe must have a minimum diameter of 50 mm and must be fed into a sewer in such a way that it is safe from frost. Do not discharge the condensate directly into clearing tanks or cess pits. The aggressive vapours and a condensate pipe laid in an area which is not frost-free can destroy the evaporator.

5.3 Sound

To prevent solid-borne sound from being transmitted to the heating system, we recommend connecting the heat pump to the heating system using a flexible hose.

Installed air ducts should be sound-isolated from the heat pump to prevent the transmission of solid-borne sound to the ducts.

6 Assembly

6.1 General

The following connections need to be established on the heat pump:

- Fresh and exhaust air
- Flow and return of the heating system
- Communication line (heat pump manager)
- Control voltage line (heat pump manager)
- Supply voltage line (electrical distribution system)
- Condensate outflow

6.2 Air connection

i NOTE

Do not restrict or block the area around the intake or the air outlet area.

i NOTE

Only operate the heat pump with the air ducts connected.

The glass fibre reinforced concrete air ducts offered as accessories are moisture-resistant and diffusion-free.

The following components are available:

- Channel
- Bend
- Connection set
- Connection frame
- Sealing collar

The sealing collar is used to seal the air ducts on the heat pump. The air ducts themselves are not screwed directly onto the heat pump. When the system is installed ready for operation, only the rubber seal comes into direct contact with the heat pump. This guarantees easy assembly and disassembly of the heat pump and also ensures that solid-borne noise is well insulated.

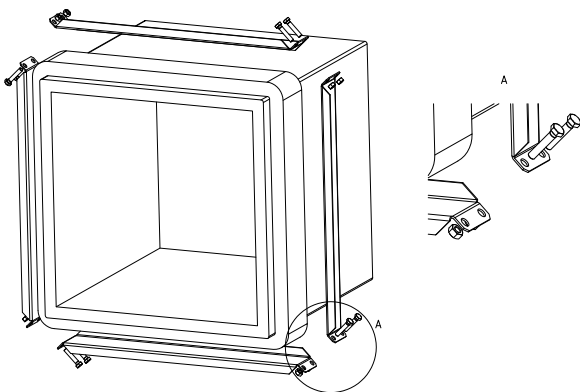

Connection of onsite air duct

If an alternative type of air duct is used to the one available as an accessory, the external and internal dimensions as specified in the drawing must be adhered to. Also ensure that the vibration and duct insulation are adequate.

If flange-mounted air ducts are used, connecting stubs are secured on the air inlet and air outlet sides of the evaporator with 4 M8 x 16 hexagon bolts in the threaded holes provided. When doing this, ensure that both air duct stubs touch only the insulation. There should be no contact with the external sheeting.

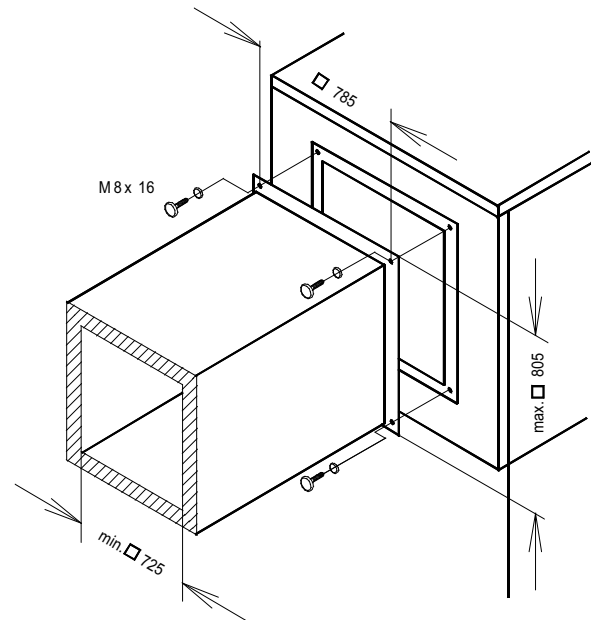

6.3 Connection on heating side

The heating system connections on the heat pump have a 1 1/4" external thread. A spanner must be used to firmly grip the transitions when connecting the heat pump.

⚠ CAUTION!

Fault on the safety switching equipment of the hydraulic circuit intended for pressure limitation. Risk of injury!

- ▶ **The safety switching equipment of the hydraulic circuit intended for pressure limitation must be checked for proper installation and functionality before commissioning.**

Before connecting the heating water system to the heat pump, the heating system must be flushed to remove any impurities, residue from sealants, etc. Any accumulation of deposits in the liquefier may cause the heat pump to completely break down. For systems in which the heating water flow rate can be shut off via the radiator or thermostat valves, an overflow valve must be installed by the customer in a heating bypass downstream from the heat pump. This ensures a minimum heating water flow rate through the heat pump and helps to avoid faults.

Once the heat pump has been connected to the heating system, it must be filled, purged and pressure-tested.

6.4 Water Quality in Heating Systems

6.4.1 Scale Formation

Scale formation in heating systems cannot be avoided, but in systems with flow temperatures below 60 °C the problem is so small that it is negligible. With high-temperature heat pumps and in particular with bivalent systems in the higher performance range (heat pump + boiler combination), flow temperatures of 60 °C and more can be achieved. One preferred method for preventing scale formation is softening because this permanently removes alkaline earths (calcium and magnesium ions) from the heating system.

The following values for water quality in heating water and cold water must be observed and checked during an on-site check:

- Degree of hardness
- Conductivity
- pH value
- Filterable materials

The following (limit) values must absolutely be observed:

- Maximum degree of hardness in filling water and supplementary water 11 dGH.
- The conductivity in demineralised water (DM water) (low-salt) may not be greater than 100 µS/cm.
- The conductivity in partially demineralised water (saline) may not be greater than 500 µS/cm.
- The pH value must be between 8.2 and 9.
- The limit value for filterable materials in heating water is < 30 mg/l

If necessary, for example in bivalent systems, the specifications listed in the table below must also be observed, or the precise guidelines for filling water and supplementary water and the total hardness must be taken from the table in accordance with VDI 2035 – Sheet 1.

i NOTE

The specific volumes of a heating system must be determined before filling the system.

The saturation index SI is used to determine whether water has a tendency towards lime dissolution or lime separation. This shows whether the pH value corresponds to a neutral pH point or by how much it undershoots it due to excess acid or by how much it exceeds it due to carbonic acid deficit. At a saturation index below 0, the water is aggressive and will tend towards corrosion. At a saturation index above 0, the water is calcareous.

The saturation index SI should be between $-0.2 < 0 < 0.2$

Filling and supplementary water as well as heating water, depending on heat output			
Overall heat output in kW	Total alkaline earths in mol/m ³ (Total hardness in dGH)		
	≤ 20	> 20 to ≤ 50	> 50
	Specific system volume in l/kW Heat output ¹		
≤ 50 specific water content heat generator > 0.3 k per kW ²	none	≤ 3.0 (16.8)	< 0.05 (0.3)
≤ 50 specific water content heat generator > 0.3 k per kW ² (e.g. circulating water heaters) and systems with electric heating elements	≤ 3.0 (16.8)	≤ 1.5 (8.4)	
> 50 kW to ≤ 200 kW	≤ 2.0 (11.2)	≤ 1.0 (5.6)	
> 200 kW to ≤ 600 kW	≤ 1.5 (8.4)	< 0.05 (0.3)	
> 600 kW	< 0.05 (0.3)	< 0.05 (0.3)	
Heating water, depending on heating output			
Operating mode	Electrical conductivity in µS/cm		
Low-salt ³	> 10 to ≤ 100		
Containing salt	> 100 to ≤ 1500		
	Appearance		
	clear, free from sedimentary substances		

1. For the purpose of calculating the specific system volume, the smallest individual heat output is to be used for systems with several heat generators.
2. In systems with several heat generators with different specific water contents, the smallest specific water content is decisive.
3. Full softening is recommended for systems with aluminium alloys.

Fig. 6.1: Guideline values for filling and supplementary in accordance with VDI 2035

⚠ CAUTION!

When using demineralised water, ensure that the minimum permissible pH value of 8.2 is not undershot. Failure to comply with this value can result in the heat pump being destroyed.

6.4.2 Corrosion

The VDI 2035 recommends the use of partially demineralised water or demineralised water in systems with larger-than-average specific system volumes of 50 l/kW.

These measures (e.g. pH stabilizers) are implemented to set the pH value of the heating water to minimise the risk of corrosion in the heat pump and in the heating system.

Irrespective of the legal requirements, the following limit values in the heating water used for various substances must not be undershot or exceeded. This is to ensure safe operation of the heat pump. A water analysis must be carried out before commissioning the system. If the water analysis produces a "-" for a maximum of one indicator or a "o" for a maximum of two indicators, the analysis must be classed as negative.

Evaluation characteristic	Concentration range (mg/l or ppm)	Stainless steel	Copper
Bicarbonate (HCO ₃ ⁻)	< 70	+	o
	70 - 300	+	+
	> 300	+	o
Sulphate (SO ₄ ²⁻)	< 70	+	+
	70 - 300	o	o/-
	> 300	-	-
Hydrogencarbonate/sulphate HCO ₃ ⁻ /SO ₄ ²⁻	> 1.0	+	+
	< 1.0	o	-
Electrical conductivity ¹	< 10 µS/cm	o	o
	10 - 500 µS/cm	+	+
	> 500 µS/cm	o	o
pH value ²	< 6.0	-	-
	6.0 - 8.2	o	o
	8.2 - 9.0	+	+
	> 9.0	o	o
Ammonium (NH ₄ ⁺)	< 2	+	+
	2 - 20	o	o
	> 20	-	-
Chloride ions (Cl ⁻)	< 50	+	+
	50 - 150	o	o
	> 150	-	-
Free chlorine (Cl ₂)	< 0.5	+	+
	0.5 - 5	-	o
	> 5	-	-
Hydrogen sulphide (H ₂ S)	< 0.05	+	+
	> 0.05	+	o/-
Carbon dioxide (CO ₂)	< 5	+	+
	5 - 10	+	o
	> 10	o	-
Nitrate (NO ₃ ⁻)	< 100	+	+
	> 100	o	o
Iron (Fe)	< 0.2	+	+
	> 0.2	o	o
Aluminium (Al)	< 0.2	+	+
	> 0.2	+	o
Manganese (Mn)	< 0.05	+	+
	> 0.05	o	o

Saturation Index	< -0.2	o	o
	-0.2 - 0.1	+	+
	0.1 - 0.2	+	o
	> 0.2	o	o
Filterable materials	< 30	+	+
	> 30	-	-
Total hardness	< 6 °dGH	o/+	o/+
	6 - 11 °dGH	+	+
	> 11 °dGH	-	-
Oxygen (O ₂)	< 0.02	+	+
	< 0.1	+/o	+/o
	> 0.1	-	-
Nitrite (NO ₂ ⁻)	< 0.1	+	+
	> 0.1	-	-
Sulphide (S ²⁻)	< 1.0	+	+
	> 1.0	-	-

1. If the limit values in the VDI 2035 are more restrictive, these apply accordingly.

2. When using demineralised water, ensure that the minimum permissible pH value of 8.2 is not undershot. Failure to comply with this value can result in the heat pump being destroyed.

Fig. 6.2: Limit values for the quality of heating water

Resistance of copper-soldered or welded stainless-steel plate heat exchangers to the substances present in water:

Notes

- "+" = Normally good resistance
- "o" = Corrosion problems may arise, particularly if several factors receive an evaluation of "o"
- "-" = Should not be used

i NOTE

The water quality should be checked again after 4 to 6 weeks, as the quality could change during the first few weeks of operation due to chemical reactions.

i NOTE

It is mandatory to use hydraulically closed systems. It is not permissible to use any open hydraulic systems!

Minimum heating water flow rate

The minimum heating water flow rate through the heat pump must be assured in all operating states of the heating system. This can be accomplished, for example, by installing either a dual differential pressureless manifold or an overflow valve. The procedure for setting an overflow valve is described in the chapter "Commissioning". When the minimum heating water flow is undershot, the plate heat exchanger in the refrigeration circuit can freeze, which can lead to total loss of the heat pump.

The nominal flow rate is specified depending on the max. flow temperature in the device information and must be taken into account during planning. With design temperatures below 30 °C in the flow, the design must be based on the max. volume flow with 5 K spread for A7/W35.

The specified nominal flow rate (see "Device information" on page 16.) must be assured in all operating states. A built-in flow rate sensor is used only for switching off the heat pump in the event of an unusual and abrupt drop in the heating water flow rate and not for monitoring and fusing the nominal flow rate.

i NOTE

The use of an overflow valve is only recommended for panel heating and a maximum heating water flow of 1.3 m³/h. System faults may result if this is not observed.

Frost protection

A method of manual drainage (see illustration) should be provided for heat pumps which are exposed to frost. The frost protection function of the heat pump manager is active whenever the heat pump manager and the heat circulating pump are ready for operation. In the event of decommissioning or power failure, the system must be drained and, if necessary, blown out at the points shown (see illustration). For heat pump systems where a power failure cannot be detected (holiday home), the heating circuit must be operated with suitable non-toxic anti-freeze (such as polypropylene glycol) added at the concentration specified by the antifreeze manufacturer.

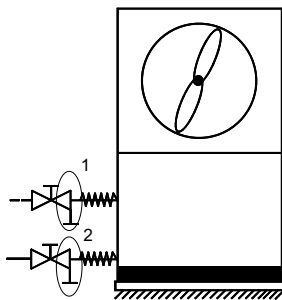

Fig. 6.3:

⚠ CAUTION!

Swallowing or contact with glycol and glycol mixtures. Risk of poisoning!

- ▶ When using glycol and glycol mixtures, the valid national and regional regulations on environmental protection, water protection and worker protection must be observed.
- ▶ Workers must be instructed in the dangers and risks associated with glycol and glycol mixtures.
- ▶ In Germany, operating instructions in accordance with §14 of the Ordinance on Hazardous Substances (GefStoffV) must be created. Otherwise, country-specific regulations must be observed.

6.5 Electrical connection

6.5.1 General

All electrical installation work must be carried out by a trained electrician or a specialist for the specified tasks in accordance with the

- installation and operating instructions,
- country-specific installation regulations (e.g. VDE 0100),
- technical connection conditions of the energy supplier
- and supply grid operator (e.g. TAB) and
- local conditions.

To ensure that the frost protection function of the heat pump works properly, the heat pump manager must remain connected to the power supply and the flow must be maintained through the heat pump at all times.

The switching contacts of the output relay are interference-suppressed. Therefore, depending on the internal resistance of the measuring instrument, a voltage can also be measured when the contacts are open. However, this will be much lower than the line voltage.

Controller terminals -N0/J2..J15; -N1/J1..15, J25 and J26 or the LV adapter boards are connected to extra-low voltage. If, due to a wiring error, the line voltage is mistakenly connected to these points, the controller will be destroyed.

6.5.2 Electrical installation work

3 lines/cables must be routed to the heat pump in total:

- A standard 5-core cable is used to connect the heat pump to the power supply.

The cable must be provided on-site. The conductor cross section is selected in accordance with the power consumption of the heat pump (see attachment Device Information) and the applicable VDE (EN) and VNB regulations. An all-pole disconnecting device with a contact gap of at least 3 mm (e.g. utility blocking contactor or power contactor) must be installed in the heat pump power supply. A 3-pole circuit breaker with joint tripping of all outer conductors (trip current in accordance with device information) provides the short circuit protection taking into account the layout of the internal wiring.

The relevant components in the heat pump contain an internal overload protection.

When connecting, ensure that the incoming supply has a clockwise rotating field.

Phase sequence: L1, L2, L3.

i NOTE

Ensure that there is a clockwise rotating field: With incorrect wiring, starting of the heat pump is prevented. A corresponding warning is indicated on the display of the heat pump manager (adjust wiring).

- The control voltage is supplied via the heat pump manager. A 3-pole line must be laid for this in accordance with the electrical documentation. Further information on the wiring of the heat pump manager is available in the heat pump manager operating instructions.
- A shielded communication line (e.g. data line; shielded: J-Y(ST)Y 2 x 2x0.6 (not included in the scope of supply) connects the heat pump manager to the refrigeration circuit controller installed in the heat pump. More detailed instructions can be found in the heat pump manager operating instructions and in the electrical documentation.

i NOTE

The communication cable is necessary for the function of air-to-water heat pumps. It must be shielded and laid separately from the mains cable.

6.5.3 Demand sensor connection

The demand sensor R2.2 (NTC 10) is included with the heat pump manager. It must be installed depending on the hydraulics used (see Appendix Chap. 3 on P. V).

If a demand sensor is not connected, the second heat generator cannot be controlled with the heat pump manager in the event of an interruption in communication.

i NOTE

The return sensor R2 installed in the heat pump is active when the compressor is running and must not be disconnected.

7 Commissioning

7.1 General

To ensure that commissioning is performed correctly, it should only be carried out by an after-sales service technician authorised by the manufacturer. This may be a condition for an additional warranty (see "Warranty service").

7.2 Preparation

The following items must be checked prior to commissioning:

- All of the heat pump connections must be installed as described in Chapter 6.
- The transport locks on the compressor must be removed.
- All valves which could impair the proper flow of the heating water in the heating circuit must be open.
- The air intake and air outlet paths must be clear.
- The fan must turn in the direction indicated by the arrow.
- The settings of the heat pump manager must be adapted to the heating system in accordance with the operating instructions.
- Ensure that the condensate drain functions properly.
- The hydraulic network must be flushed correctly before installing the heat pump. This includes the supply line to the heat pump. Only when flushing is complete can the heat pump be hydraulically integrated.
- The dirt traps present as standard or included for assembly must be inspected between 4 and 8 weeks after the heat pump is commissioned or changes made to the heating system and cleaned if necessary. Further maintenance intervals must be scheduled depending on the level of soiling, which must be defined and carried out by a suitably qualified person.

Special notes for the integration of heat pumps in existing systems (renovations):

The existing heat distribution network (pipe materials, connection types, etc.) and the existing heating systems (e.g. radiators, underfloor heating, etc.) can impact the quality of the water in existing systems. Particularly when welded steel pipes or pipes that are not oxygen diffusion-proof are used, deposits, scaling, silting or similar may be present that can cause damage in the heat pump system. This can result in a total failure of the heat pump. The following measures must be observed to avoid this:

- Compliance with the water properties and water quality
- Flushing of the hydraulic system
- Maintenance interval of the dirt traps
- If silting or ferromagnetic particles are to be expected in the hydraulic network, dirt separators or magnetite separators must be installed on-site before the medium enters the heat pump. The maintenance intervals must be defined by a suitably qualified person.

7.3 Procedure

The heat pump is commissioned via the heat pump manager. Settings should be made in compliance with the heat pump manager's instructions.

If an overflow valve is fitted to ensure a minimum heating water flow, the overflow valve must be set in accordance with the requirements of the respective heating system. Incorrect adjustment can lead to faulty operation and increased energy consumption. We recommend carrying out the following procedure to set the overflow valve correctly:

Close all heating circuits that may also be closed during operation (depending on how the heat pump is being used) so that the most unfavourable operating status with regard to the water flow is achieved. This normally means the heating circuits of the rooms on the south and west sides of the building. At least one heating circuit must remain open (e.g. bathroom).

The overflow valve should be opened far enough to produce the maximum temperature spread between the heat flow and heat return flow, listed in the following table, for the current heat source temperature. The temperature spread should be measured as close as possible to the heat pump. The heating element of mono energy systems should be disconnected during commissioning.

Heat source temperature		max. temperature spread between flow and return
from	to	
-20 °C	-15 °C	4 K
-14 °C	-10 °C	5 K
-9 °C	-5 °C	6 K
-4 °C	0 °C	7 K
1 °C	5 °C	8 K
6 °C	10 °C	9 K
11 °C	15 °C	10 K
16 °C	20 °C	11 K
21 °C	25 °C	12 K
26 °C	30 °C	13 K
31 °C	35 °C	14 K

At heating water temperatures under 7°C, commissioning is not possible. The water in the buffer tank must be heated with the 2nd heat generator to at least 18 °C.

To ensure problem-free commissioning, the following procedure is to be implemented:

- 1) Close all consumer circuits.
- 2) Ensure that the heat pump has the correct water flow.
- 3) Select "Winter" mode on the heat pump manager.
- 4) In the special functions menu, start the "Commissioning" program.
- 5) Wait until a return temperature of at least 25 °C has been reached.
- 6) Now slowly reopen the heating circuit valves in succession so that the heating water flow rate is constantly raised by slightly opening the respective heating circuit. The heating water temperature in the buffer tank must not be allowed to drop below 20 °C during this process. This ensures that the heat pump can be defrosted at any time.
- 7) When all heating circuits are fully open and a return temperature of at least 18 °C is maintained, the commissioning is complete.

i NOTE

Operating the heat pump at low system temperatures may cause the heat pump to break down completely.

8 Cleaning / maintenance

8.1 Care

To protect the paintwork, avoid leaning anything against the device or putting objects on the device. External heat pump parts can be wiped with a damp cloth and commercially available domestic cleaner.

i NOTE

Never use cleaning agents containing sand, soda, acid or chloride, as these can damage the surfaces.

To prevent faults due to sediment in the heat exchanger of the heat pump, ensure that the heat exchanger in the heating system cannot be contaminated. We recommend protecting the evaporator by installing a bird guard in the inlet duct. At least 80% of the cross section of the grating should be open. Should operating malfunctions due to contamination still occur, however, the system should be cleaned as described below.

8.2 Cleaning the heating system

i NOTE

Pressure relief devices must be checked and maintained regularly.

i NOTE

The integrated dirt trap must be cleaned at regular intervals.

The maintenance intervals should be defined according to the degree of soiling in the system. The filter insert should also be cleaned.

For cleaning, the heating circuit must be made pressureless in the vicinity of the dirt trap, the filter compartment unscrewed, and the filter insert removed and cleaned. Assembly carried out in reverse order requires attention to correct assembly of the screen inserts and tightness of the screw joints.

The ingress of oxygen into the heating water circuit may result in the formation of oxidation products (rust), particularly if steel components are used. These enter the heating system via the valves, the circulating pumps and/or plastic pipes. A diffusion-resistant installation is therefore essential, especially with regard to the piping of underfloor heating systems.

i NOTE

We recommend the installation of a suitable corrosion protection system to prevent the formation of deposits (e.g. rust) in the condenser of the heat pump.

Residue from lubricants and sealants may also contaminate the heating water.

In the event of severe contamination leading to a reduction in the performance of the liquefier in the heat pump, the system must be cleaned by a heating technician.

Based on current information, we recommend using a 5% phosphoric acid solution for cleaning purposes. However, if cleaning needs to be performed more frequently, a 5% formic acid solution should be used.

In both cases, the cleaning fluid should be at room temperature. We recommend flushing the heat exchanger in the direction opposite to the normal flow direction.

To prevent acidic cleaning agents from entering the heating system circuit, we recommend connecting the flushing device directly to the flow and return of the liquefier of the heat pump.

It is then important that the system be thoroughly flushed using appropriate neutralising agents to prevent any damage from being caused by cleaning agent residue remaining in the system.

Acids must be used with care and the regulations of the employers liability insurance associations must be adhered to.

The instructions of the cleaning agent manufacturer must always be observed.

8.3 Cleaning the air system

Air channels, air ducts, evaporator, ventilator and condensate outflow should be cleaned of contamination (leaves, twigs, etc.) before each new heating period. To do this, the heat pump must be opened at the side. The bottom section should be opened first, followed by the top section.

Remove and rehang the side panel assemblies, as described in Chapter 4.

To prevent the evaporator and the condensate tray from being damaged, do not use hard or sharp objects when cleaning.

9 Faults / troubleshooting

This heat pump is a quality product and is designed for trouble-free operation. Should a fault occur, however, it will be indicated on the heat pump manager display. In this case, consult the "Faults and troubleshooting" page in the operating instructions of the heat pump manager.

If you cannot correct the fault yourself, please contact your after-sales service technician.

10 Decommissioning/disposal

Before removing the heat pump, disconnect it from the power source and close all valves. The heat pump must be dismantled by trained personnel. Observe all environmental requirements regarding the recovery, recycling and disposal of materials and components in accordance with all applicable standards. Particular attention should be paid to the proper disposal of refrigerants and refrigerant oils.

i NOTE

Use suitable transport devices.

⚠ CAUTION!

Work may only be carried out on the device outdoors in dry weather conditions. Risk of damage to the device or electric shock!

- ▶ **In wet weather conditions such as rain, snow etc., the housing of the heat pump must be kept properly closed.**

⚠ CAUTION!

Weather-related conditions on transport routes. Risk of injury due to slipping!

- ▶ **Transport routes must be kept clear and weather-related conditions such as ice and snow must not impair safe transport.**

⚠ CAUTION!

Do not stand near the device during storms. Risk of lightning!

- ▶ **Do not stand in the immediate vicinity of the heat pump.**

11 Device information

		LI 1422C	LI 1826C
1 Type and order code		LI 1422C	LI 1826C
2 Design			
2.1 Heat source		Air	Air
2.2 Seasonal coefficient of performance (COP) average climate 35 °C / 55 °C		179 % / 135 %	175 % / 135 %
2.3 Controller		WPM Touch	WPM Touch
2.4 Heat generator installation location		Inside	Inside
2.5 Heat source installation location		Inside	Inside
2.6 Thermal energy metering		Integrated	Integrated
2.7 Performance levels		2	2
3 Operating limits			
3.1 Heating water flow / return ¹	°C	up to 60 ± 2K / from 22	up to 60 ± 2K / from 22
3.2 Air (heating) ¹	°C	-22 to +35	-22 to +35
3.3 Cooling water flow	°C	+7 to +20	+9 to +20
3.4 Air (cooling)	°C	+15 to +45	+15 to +45
4 Flow² / sound			
4.1 Heating water flow rate internal pressure differential			
Nominal flow rate in accordance with 14511A7 / W35 ... 30	m ³ /h / Pa	1.95 / 12900	2.5 / 12500
A7 / W45 ... 40	m ³ /h / Pa	1.85 / 11500	2.4 / 11200
A7 / W55 ... 47	m ³ /h / Pa	1.10 / 4800	1.45 / 2300
Minimum heating water flow	m ³ /h / Pa	1.10 / 4800	1.45 / ---
4.2 Cooling water flow rate / internal pressure differential			
Nominal flow rate in accordance with EN1451135 / W18 ... 23	m ³ /h / Pa	3.3 / 37000	3.0 / 19300
Minimum cooling water flow	m ³ /h / Pa	1.95 / 12900	2.5 / 12500
4.3 Sound power level according to EN12102 with A7 / W55 Indoors/outdoors ^{3 4} Normal operation	dB(A)	54 / 56	57 / 60
4.4 Sound power level according to EN12102 with A7 / W55 Indoors / outdoors ^{3 4} Reduced operation ⁵	dB(A)	53 / 54	55 / 58
4.5 Sound pressure level at a distance of 1 m indoors ^{3 4 6}	dB(A)	46	49
4.6 Air flow with an external static pressure differential	m ³ /h / Pa m ³ /h / Pa	5500 / 0 4000 / 25	8300 / 0 7300 / 25
5 Dimensions, weight and filling quantities			
5.1 Device dimensions ⁷	H x W x D mm	1770 x 750 x 1000	1770 x 750 x 1000
5.2 Device connections for heating	Inches	1 1/4" thread	1 1/4" thread
5.3 Weight of the transportable unit(s) incl. packaging	kg	307	326
5.4 Weight of head pump	kg	281	299
5.5 Refrigerant/total filling weight	Type/kg	R410A / 5.4	R410A / 6.6
5.6 GWP value / CO ₂ equivalent	--- / t	2088 / 11	2088 / 14
5.7 Refrigeration circuit hermetically sealed		Yes	Yes
5.8 Lubricant/total filling quantity	Type/litres	Polyolester (POE)/2.48	Polyolester (POE)/2.48
5.9 Volume of heating water in the indoor component	litres	3.8	4.0
6 Electrical connection			
6.1 Supply voltage/fusing/RCD type		3~/PE 400V (50Hz) / C16A / B	3~/PE 400V (50Hz) / C20A / B
6.2 Control voltage / fusing / RCD type		1~/N/PE 230V (50Hz) / C13A / A	1~/N/PE 230V (50Hz) / C13A / A
6.3 Degree of protection according to EN 60 529		IP 21	IP 21
6.4 Starting current limiter		Soft starter	Soft starter
6.5 Starting current	A	19	26
6.6 Nominal power consumption A2 W35/ max. power consumption ²	kW	4.7 / 8.0	5.1 / 9.9
6.7 Nominal current A2 / W35 / cos φ	A / ---	8.5 / 0.8	9.2 / 0.8
6.8 Power consumption of fan	W	up to 300	up to 400
7 Complies with the European safety regulations		8	8
8 Additional model features			

8.1 Type of defrosting		Reverse cycle		Reverse cycle	
8.2 Condensate tray frost protection/water in device is protected from freezing ⁹		Yes		Yes	
8.3 Max. operating overpressure (heat sink)	bar	3.0		3.0	
9 Heat output / COP^{2 5}					
9.1 Heat output / coefficient of performance (COP)					
		EN 14511		EN 14511	
		1	2	1	2
at A-7 / W35	kW / ---	7.5 / 3.3	13.9 / 3.1	9.8 / 3.4	18.3 / 3.2
at A2 / W35	kW / ---	9.4 / 4.1	15.9 / 3.7	11.3 / 3.9	18.6 / 3.7
at A7 / W35	kW / ---	11.7 / 5.0	(20.9 / 4.7) ¹⁰	14.2 / 4.8	(21.3 / 4.2) ¹⁰
10 Cooling capacity / coefficient of performance (COP)^{2 3}					
10.1 Cooling capacity / coefficient of performance (COP)					
		EN 14511		EN 14511	
		1	2	1	2
at A27 / W18	kW / ---	10.4 / 4.0	21.0 / 3.6	10.9 / 3.3	19.2 / 2.6
at A27 / W7	kW / ---	6.8 / 2.7	16.0 / 2.8	7.9 / 3.5	16.5 / 2.3
at A35 / W18	kW / ---	10.3 / 4.0	19.3 / 2.9	9.5 / 2.5	17.7 / 2.1
at A35 / W7	kW / ---	6.5 / 2.3	14.8 / 2.3	7.0 / 1.9	14.9 / 1.9

1. For air temperatures between -22 °C and -5 °C, flow temperature increasing from 45 °C to 60 °C.

2. This data indicates the size and capacity of the system according to EN 14511. For an analysis of the economic and energy efficiency of the system, the bivalence point and the regulation should be taken into consideration. These figures are only achieved with clean heat exchangers. Instructions for care, commissioning and operation can be found in the relevant sections of the installation and operation instructions. The specified values have the following meaning, e.g. A2/W35: Heat source temperature 2 °C and heating water flow temperature 35 °C.

3. Tonal component according to DIN 45681 Table 1 is indoors ≤ 2 dB / outdoors ≤ 1 dB

4. Sound measurement takes place with two 90° bends and weather protection grills on the intake and air outlet.

5. The heat output and COP is reduced by approx. 5% in lower operation

6. The specified sound pressure level represents the free sound area level. The measured value can vary by up to 16 dB(A), depending on the installation location.

7. Note that additional space is required for pipe connections, operation and maintenance.

8. see CE declaration of conformity

9. The heat circulating pump and the heat pump manager must always be ready for operation.

10. Special operation, normal operation above 5 °C outside temperature 1 compressor operation

12 Product information as per Regulation (EU) No 813/2013, Annex II, Table 2

Information requirements for heat pump space heaters and heat pump combination heaters							
Model	LI1422C						
Air-to-water heat pump	yes						
Water-to-water heat pump	no						
Brine-to-water heat pump	no						
Low-temperature heat pump	no						
Equipped with a supplementary heater	no						
Heat pump combination heater	no						
Parameters shall be declared for medium-temperature application, except for low-temperature heat pumps. For low-temperature heat pumps, parameters shall be declared for low-temperature application.							
Parameters shall be declared for average climate conditions:							
Item	Symbol	Value	Unit	Item	Symbol	Value	Unit
Rated heat output (*)	P_{rated}	12	kW	Seasonal space heating energy efficiency	η_s	135	%
Declared capacity for heating four part load at indoor temperature 20°C and outdoor temperature T_j				Declared coefficient of performance or primary energy ratio for part load at indoor temperature 20 °C and outdoor temperature T_j			
$T_j = -7^\circ\text{C}$	P_{dh}	13,6	kW	$T_j = -7^\circ\text{C}$	COP_d	2,28	-
$T_j = +2^\circ\text{C}$	P_{dh}	9,2	kW	$T_j = +2^\circ\text{C}$	COP_d	3,36	-
$T_j = +7^\circ\text{C}$	P_{dh}	11,5	kW	$T_j = +7^\circ\text{C}$	COP_d	4,39	-
$T_j = +12^\circ\text{C}$	P_{dh}	13,1	kW	$T_j = +12^\circ\text{C}$	COP_d	5,40	-
$T_j = \text{bivalent temperature}$	P_{dh}	12,4	kW	$T_j = \text{bivalent temperature}$	COP_d	2,04	-
$T_j = \text{operation limit temperature}$	P_{dh}	12,4	kW	$T_j = \text{operation limit temperature}$	COP_d	2,04	-
For air-to-water heat pumps				For air-to-water heat pumps:			
$T_j = -15^\circ\text{C}$ (if TOL < -20°C)	P_{dh}	-	kW	$T_j = -15^\circ\text{C}$ (if TOL < -20°C)	COP_d	-	-
Bivalent temperature	T_{biv}	-10	°C	For air-to-water heat pumps: Operation limit temperature	TOL	-10	°C
Cycling interval capacity for heating	P_{cyc}	-	kW	Cycling interval efficiency	COP_{cyc}	-	-
Degradation co-efficient (**)	C_{dh}	0,99	-	Heating water operating limit temperature	WTOL	60	°C
Power consumption in modes other than active mode				Supplementary heater			
Off mode	P_{OFF}	0,020	kW	Rated heat output (*)	P_{sup}	0	kW
Thermostat-off mode	P_{TO}	0,020	kW	Type of energy input	electrical		
Standby mode	P_{SB}	0,020	kW				
Crankcase heater mode	P_{CK}	0,000	kW				
Other items							
Capacity control	fixed			For air-to-water heat pumps: Rated air flow rate, outdoors	-	4000	m ³ /h
Sound power level, indoors/ outdoors	L_{WA}	54 /56	dB	For water-/brine-to-water heat pumps: Rated brine or water flow rate, outdoor heat exchanger	-	--	m ³ /h
Emissions of nitrogen oxides	NO_x	-	mg/kWh				
For heat pump combination heater:							
Declared load profile	-			Water heating energy efficiency	η_{wh}	-	%
Daily electricity consumption	Q_{elec}	-	kWh	Daily fuel consumption	Q_{fuel}	-	kWh
Contact details	Glen Dimplex Deutschland GmbH, Am Goldenen Feld 18, 95326 Kulmbach						
(*) For heat pump space heaters and heat pump combination heaters, the rated output P_{rated} is equal to the design load for heating $P_{designh}$, and the rated heat output of a supplementary capacity for heating $sup(T_j)$.							
(**) If C_{dh} is not determined by measurement then the default degradation is $C_{dh} = 0,9$							
(-) not applicable							

Information requirements for heat pump space heaters and heat pump combination heaters							
Model		LI1826C					
Air-to-water heat pump		yes					
Water-to-water heat pump		no					
Brine-to-water heat pump		no					
Low-temperature heat pump		no					
Equipped with a supplementary heater		no					
Heat pump combination heater		no					
Parameters shall be declared for medium-temperature application, except for low-temperature heat pumps. For low-temperature heat pumps, parameters shall be declared for low-temperature application.							
Parameters shall be declared for average climate conditions:							
Item	Symbol	Value	Unit	Item	Symbol	Value	Unit
Rated heat output (*)	P_{rated}	17	kW	Seasonal space heating energy efficiency	η_s	135	%
Declared capacity for heating foer part load at indoor temperature 20°C and outdoor temperature T_j				Declared coefficient of performance or primary energy ratio for part load at indoor temperature 20 °C and outdoor temperature T_j			
$T_j = -7^\circ\text{C}$	P_{dh}	18,1	kW	$T_j = -7^\circ\text{C}$	COP_d	2,39	-
$T_j = +2^\circ\text{C}$	P_{dh}	11,0	kW	$T_j = +2^\circ\text{C}$	COP_d	3,33	-
$T_j = +7^\circ\text{C}$	P_{dh}	13,8	kW	$T_j = +7^\circ\text{C}$	COP_d	4,30	-
$T_j = +12^\circ\text{C}$	P_{dh}	15,8	kW	$T_j = +12^\circ\text{C}$	COP_d	5,26	-
$T_j = \text{bivalent temperature}$	P_{dh}	16,8	kW	$T_j = \text{bivalent temperature}$	COP_d	2,20	-
$T_j = \text{operation limit temperature}$	P_{dh}	16,8	kW	$T_j = \text{operation limit temperature}$	COP_d	2,20	-
For air-to-water heat pumps				For air-to-water heat pumps:			
$T_j = -15^\circ\text{C}$ (if TOL < -20°C)	P_{dh}	-	kW	$T_j = -15^\circ\text{C}$ (if TOL < -20°C)	COP_d	-	-
Bivalent temperature	T_{biv}	-10	°C	For air-to-water heat pumps:			
				Operation limit temperature	TOL	-10	°C
Cycling interval capacity for heating	P_{cyc}	-	kW	Cycling interval efficiency	COP_{cyc}	-	-
Degradation co-efficient (**)	C_{dh}	0,99	-	Heating water operating limit temperature	WTOL	60	°C
Power consumption in modes other than active mode				Supplementary heater			
Off mode	P_{OFF}	0,028	kW	Rated heat output (*)	P_{sup}	0	kW
Thermostat-off mode	P_{TO}	0,020	kW	Type of energy input	electrical		
Standby mode	P_{SB}	0,020	kW				
Crankcase heater mode	P_{CK}	0,027	kW				
Other items				For air-to-water heat pumps: Rated air flow rate, outdoors			
Capacity control	fixed				-	7300	m³/h
Sound power level, indoors/ outdoors	L_{WA}	57 / 60	dB	For water-/brine-to-water heat pumps: Rated brine or water flow rate, outdoor heat exchanger	-	--	m³/h
Emissions of nitrogen oxides	NO_x	-	mg/kWh				
For heat pump combination heater:							
Declared load profile	-			Water heating energy efficiency	η_{wh}	-	%
Daily electricity consumption	Q_{elec}	-	kWh	Daily fuel consumption	Q_{fuel}	-	kWh
Contact details		Glen Dimplex Deutschland GmbH, Am Goldenen Feld 18, 95326 Kulmbach					
(*) For heat pump space heaters and heat pump combination heaters, the rated output P_{rated} is equal to the design load for heating $P_{designh}$, and the rated heat output of a supplementary capacity for heating $sup(T_j)$.							
(**) If C_{dh} is not determined by measurement nthen the default degradation is $C_{dh} = 0,9$							
(--) not applicable							

13 Dimension Drawings

13.1 Dimension Drawing

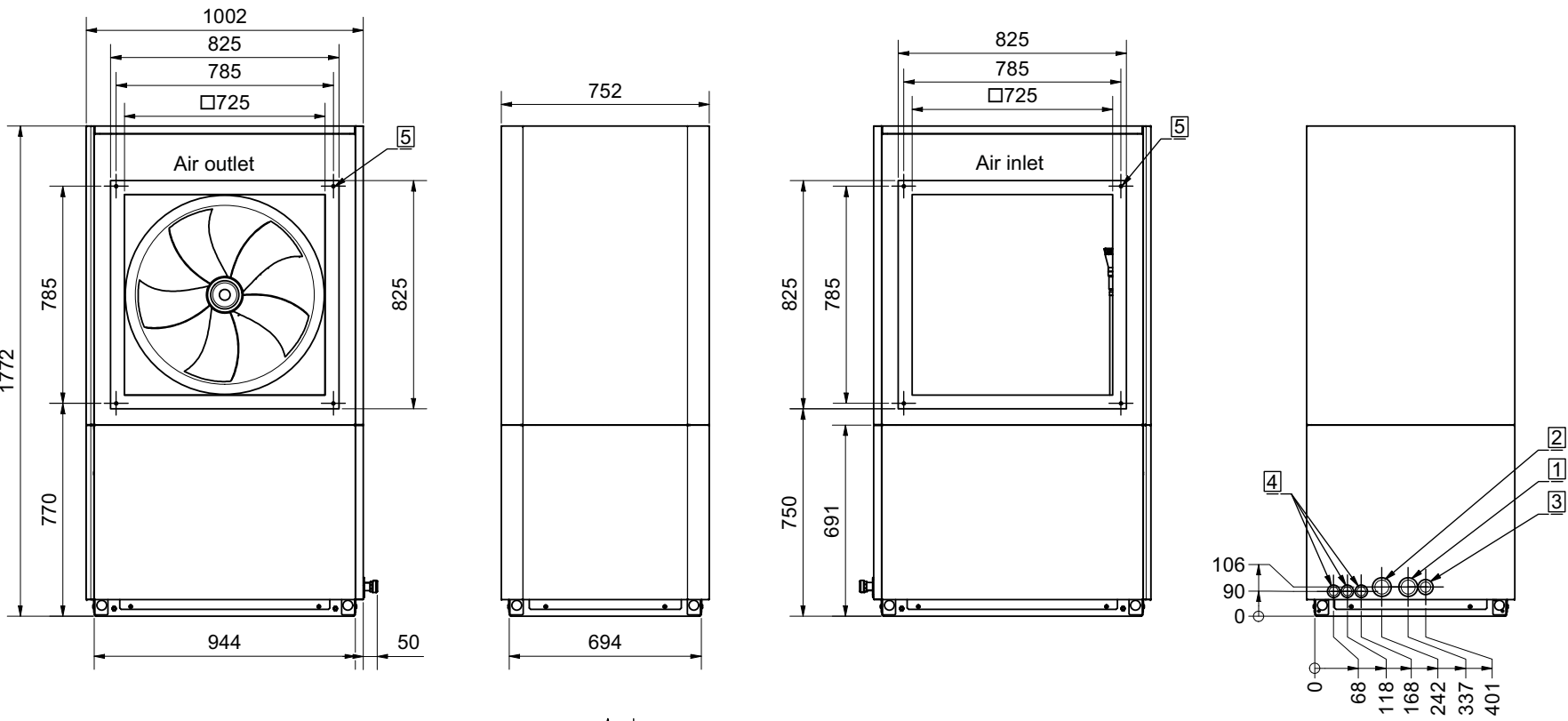

- 1 Heating water flow
Heat pump outlet
1 1/4" external thread
- 2 Heating water return flow
Heat pump inlet
1 1/4" external thread
- 3 Condensate outflow
- 4 Electric lines
- 5 4x internal thread M8 x 15

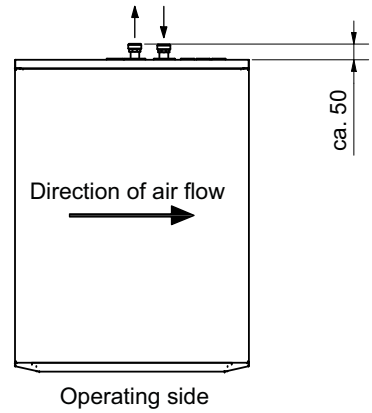

14 Diagrams

14.1 Characteristic curves for heating operation LI 1422C

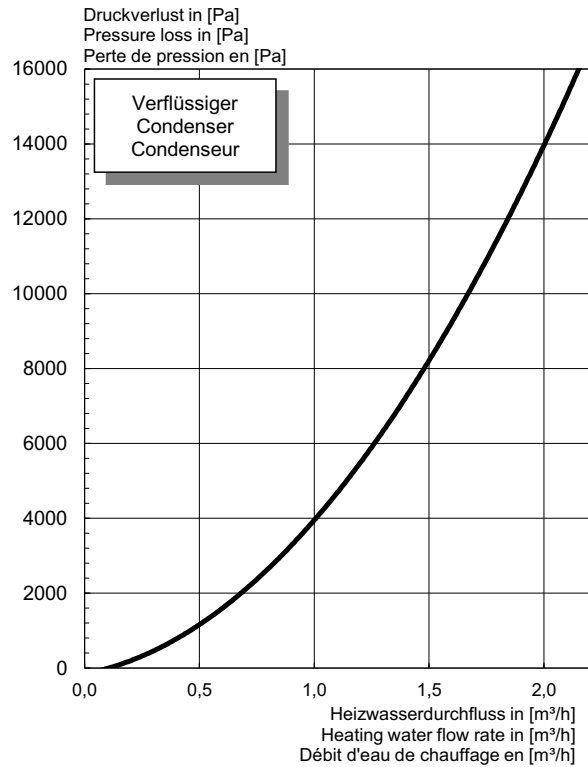
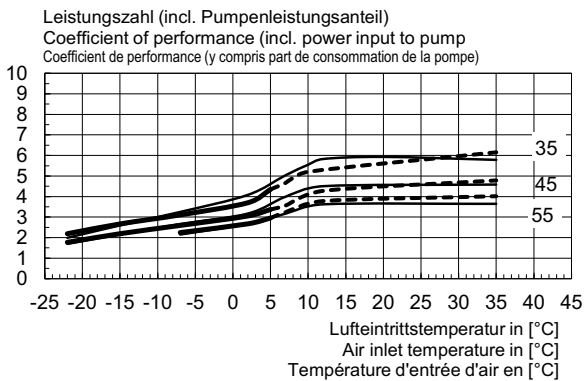
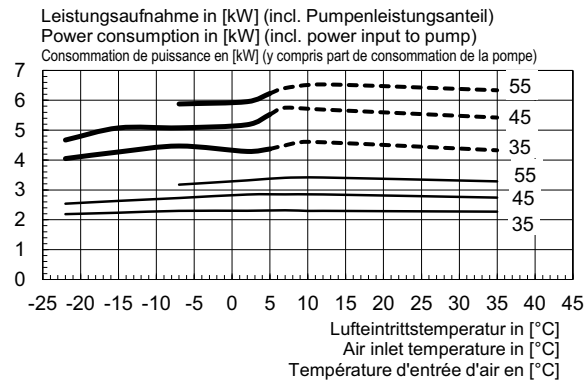
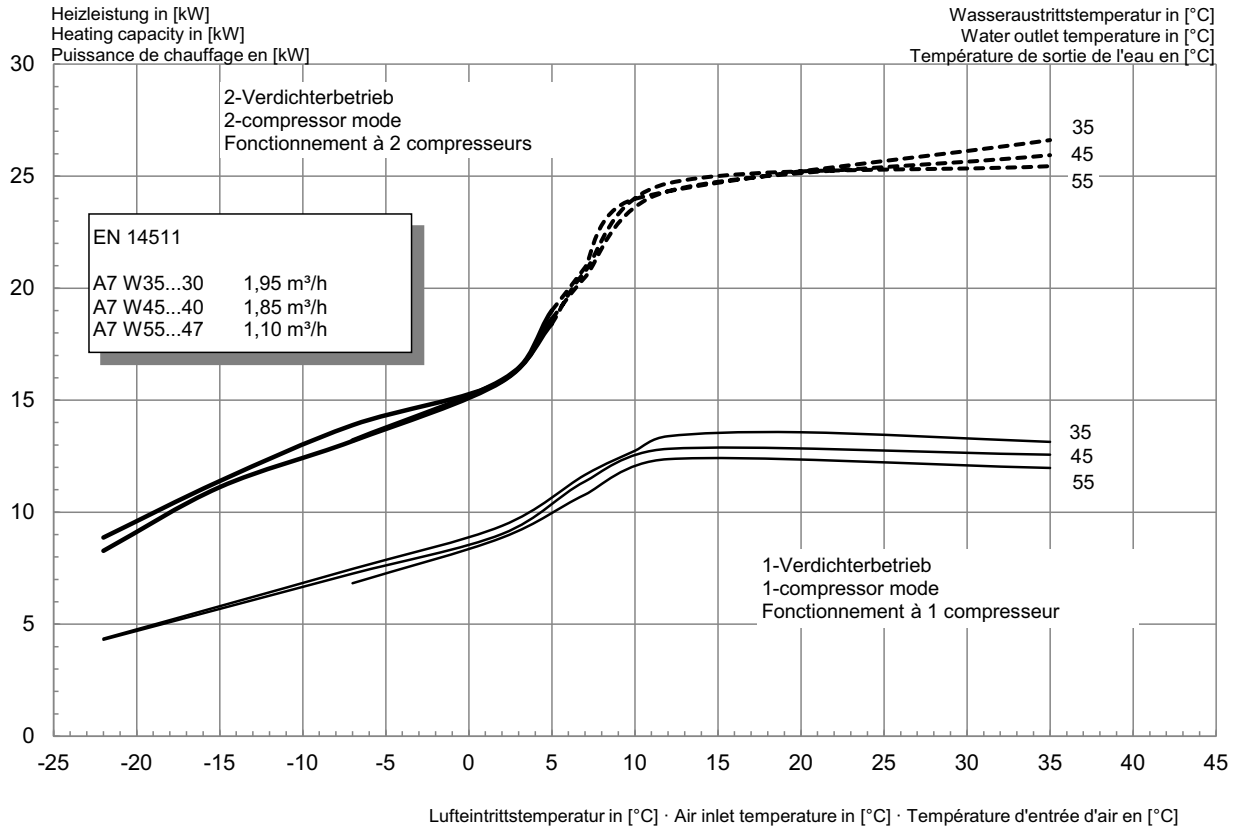

14.2 Characteristic curves for cooling operation LI 1422C

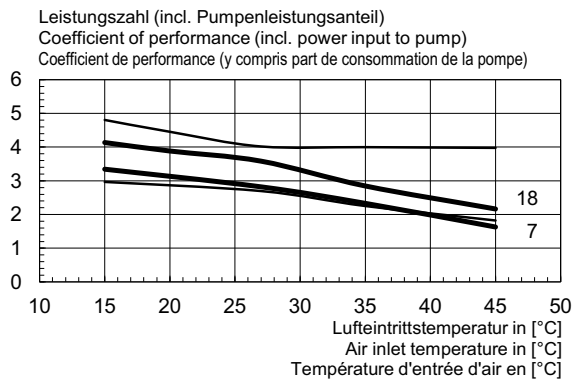
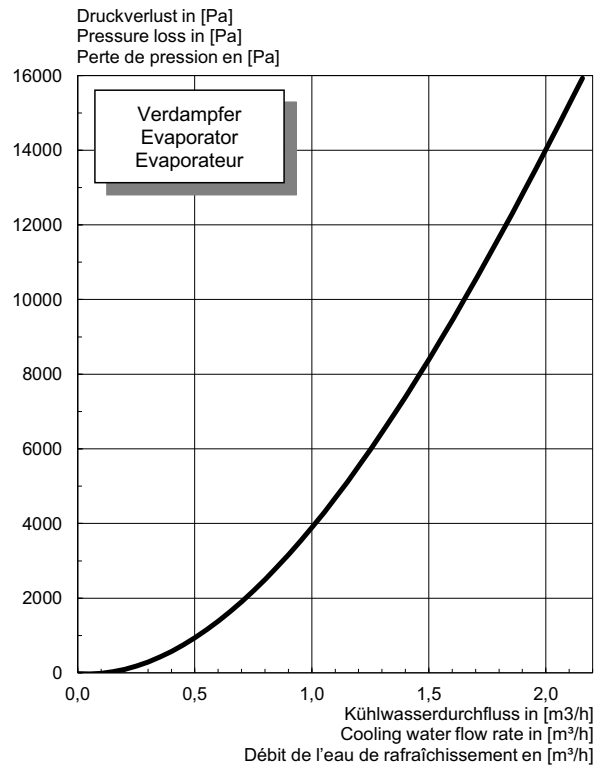
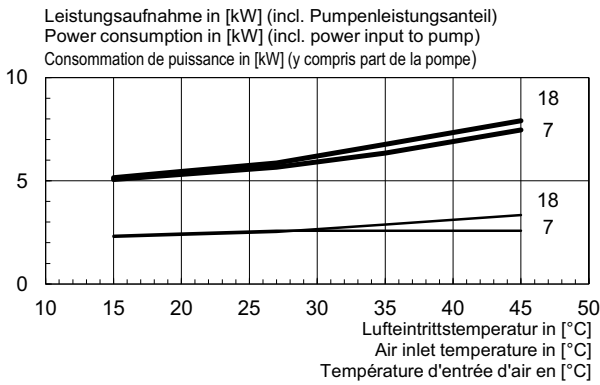
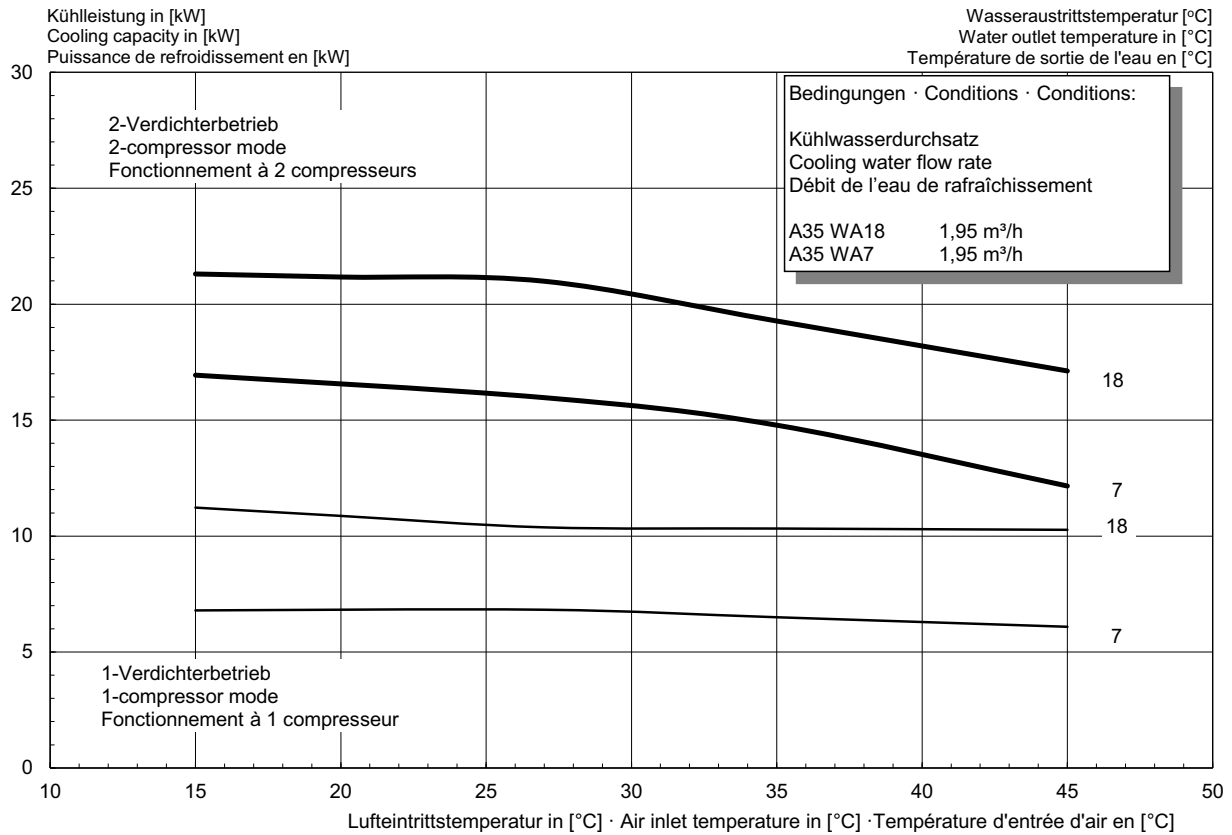

14.3 Characteristic curves for heating operation LI 1826C

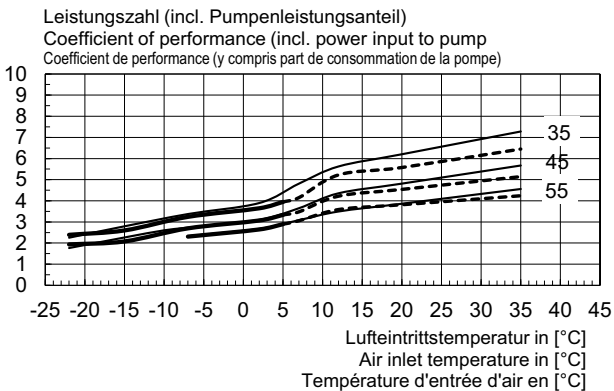
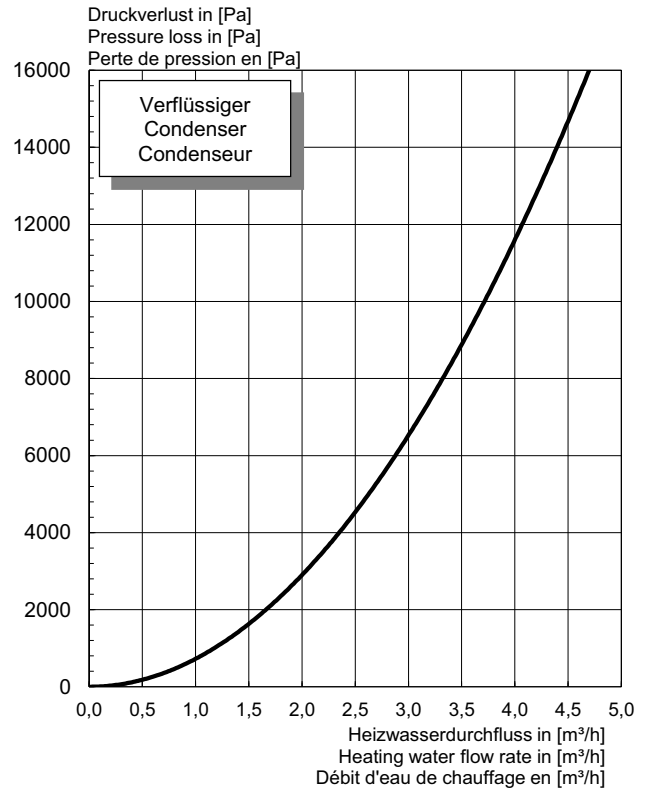
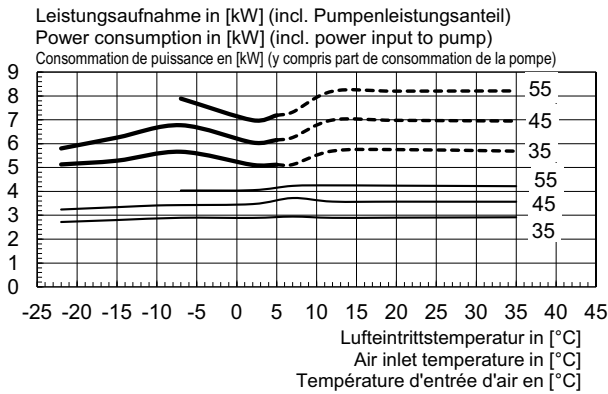
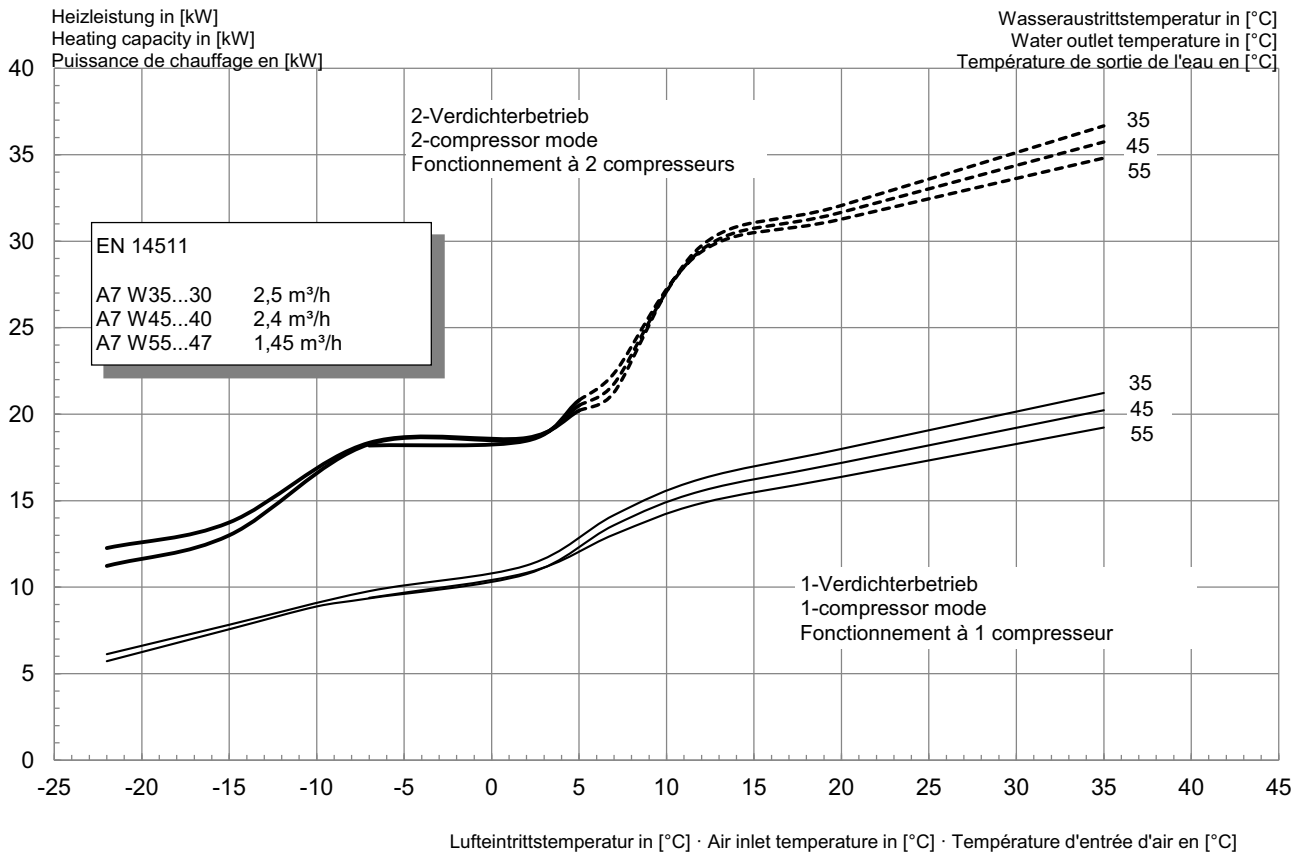

14.4 Characteristic curves for cooling operation LI 1826C

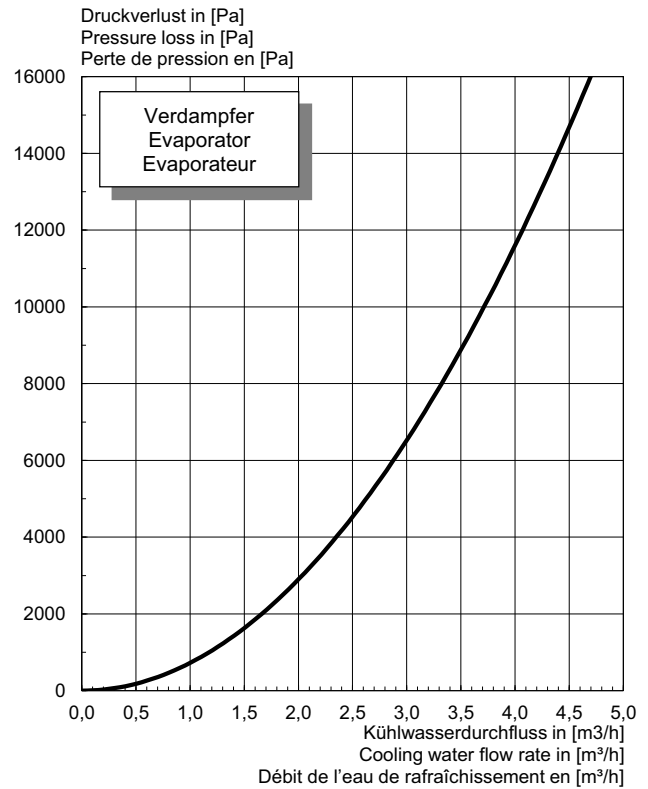
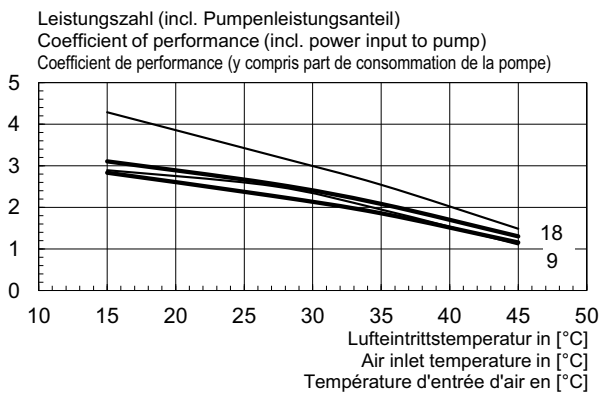
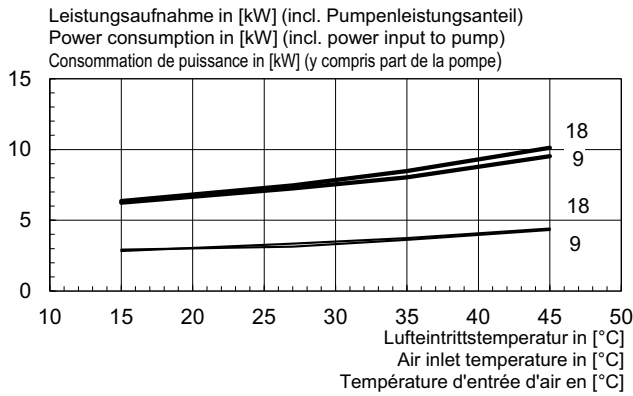
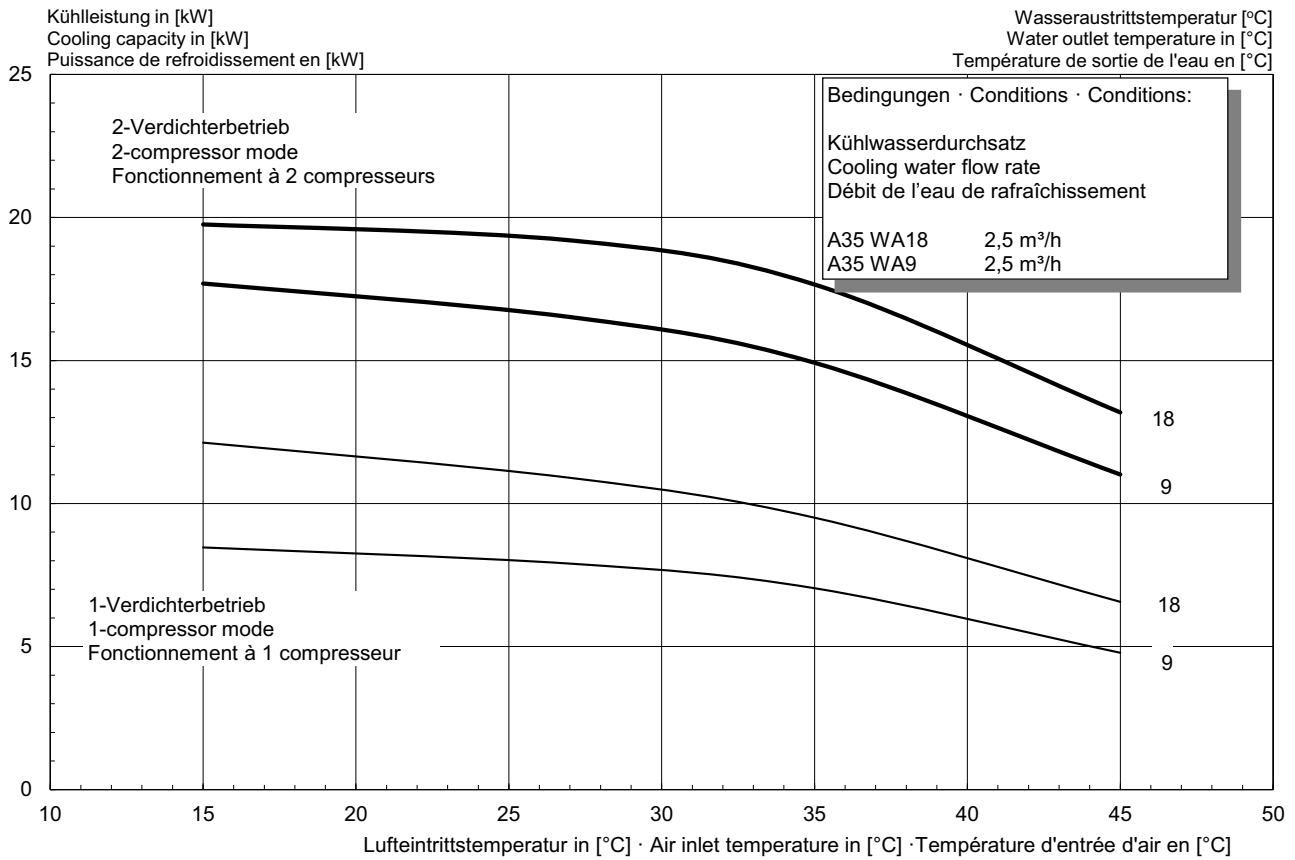

14.5 Operating limits diagram heating

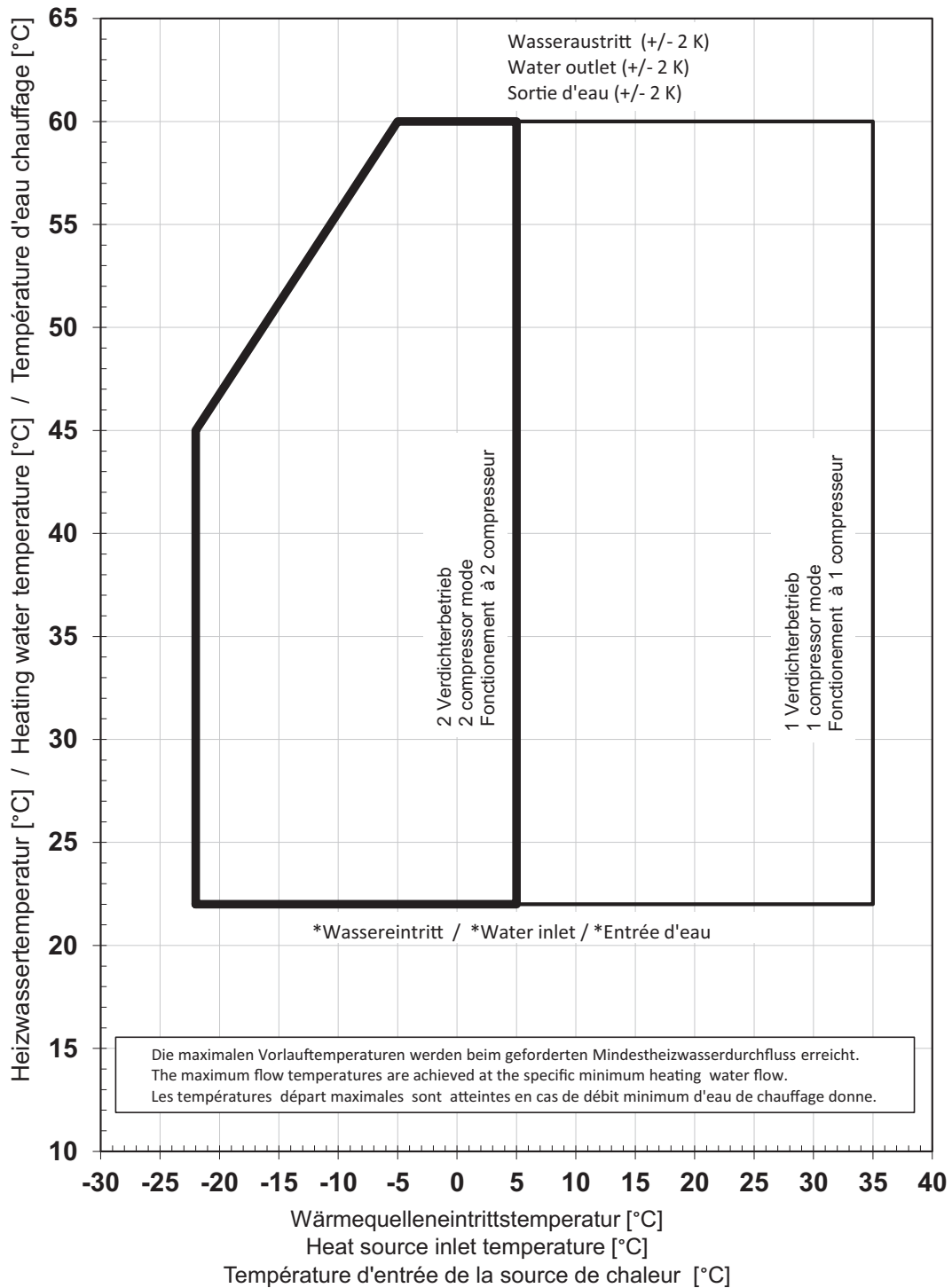

*Bei Luft/Wasser-Wärmepumpen stellt die minimale Heizwassertemperatur die Mindest-Rücklaufemperatur dar
 *For air-to-water heat pumps the minimum heating water temperature is the minimum return temperature
 *Sur les pompes à chaleur air / eau, la température minimale d'eau de chauffage correspond à la température retour minimale

14.6 Operating limits diagram cooling LI 1422C

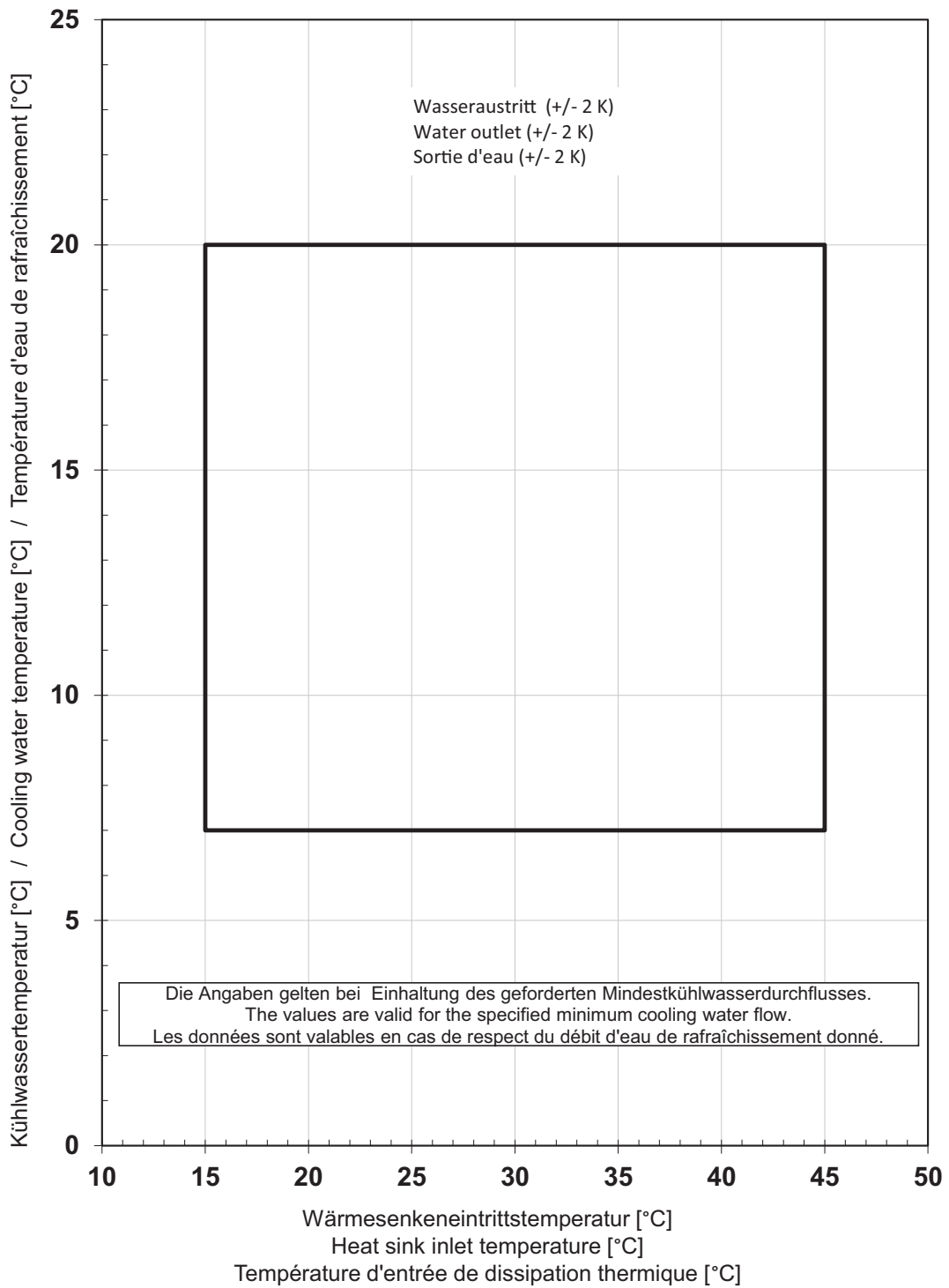

14.7 Operating limits diagram cooling LI 1826C

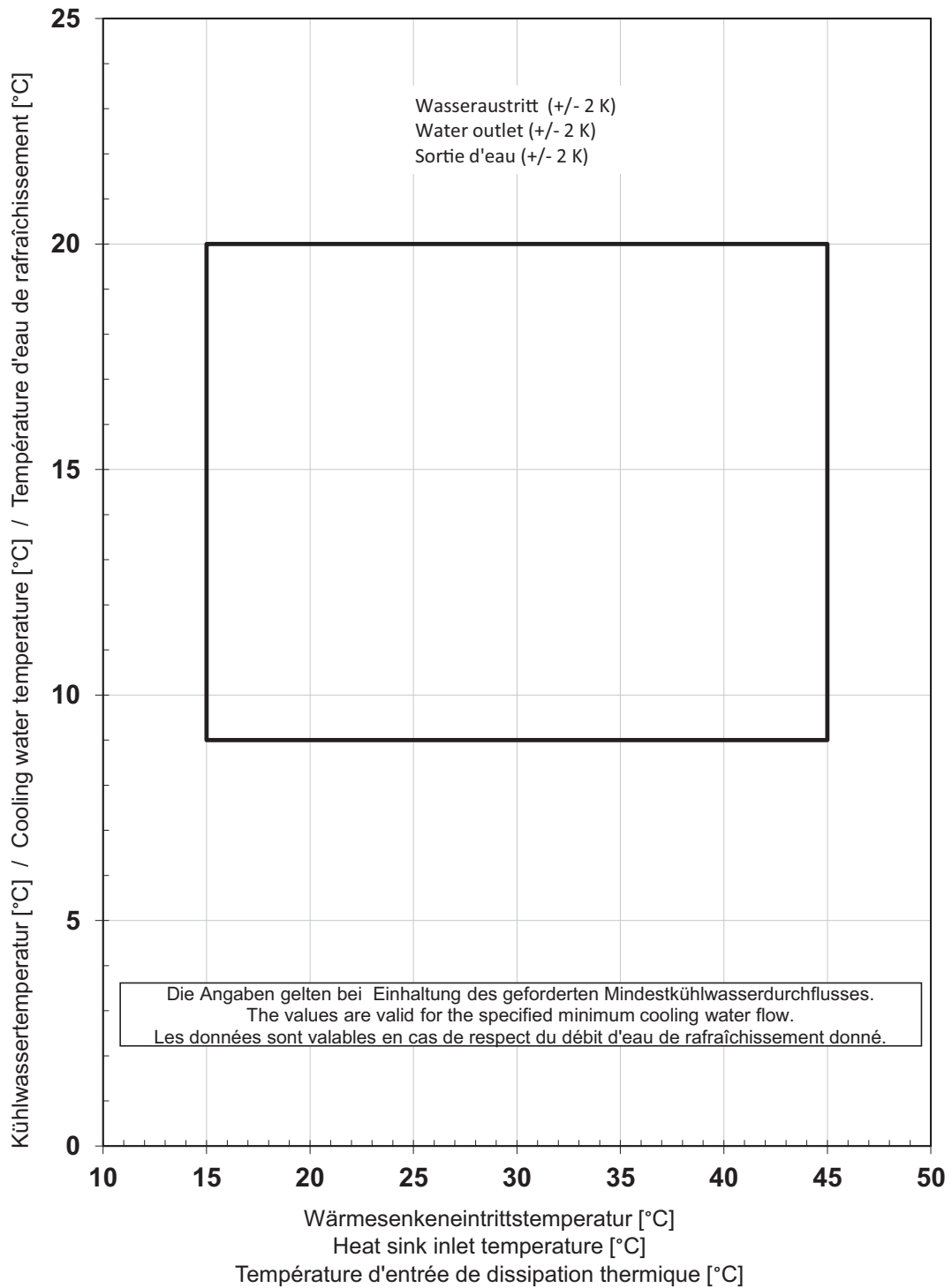

15 Integration diagram

15.1 Hydraulic integration diagrams

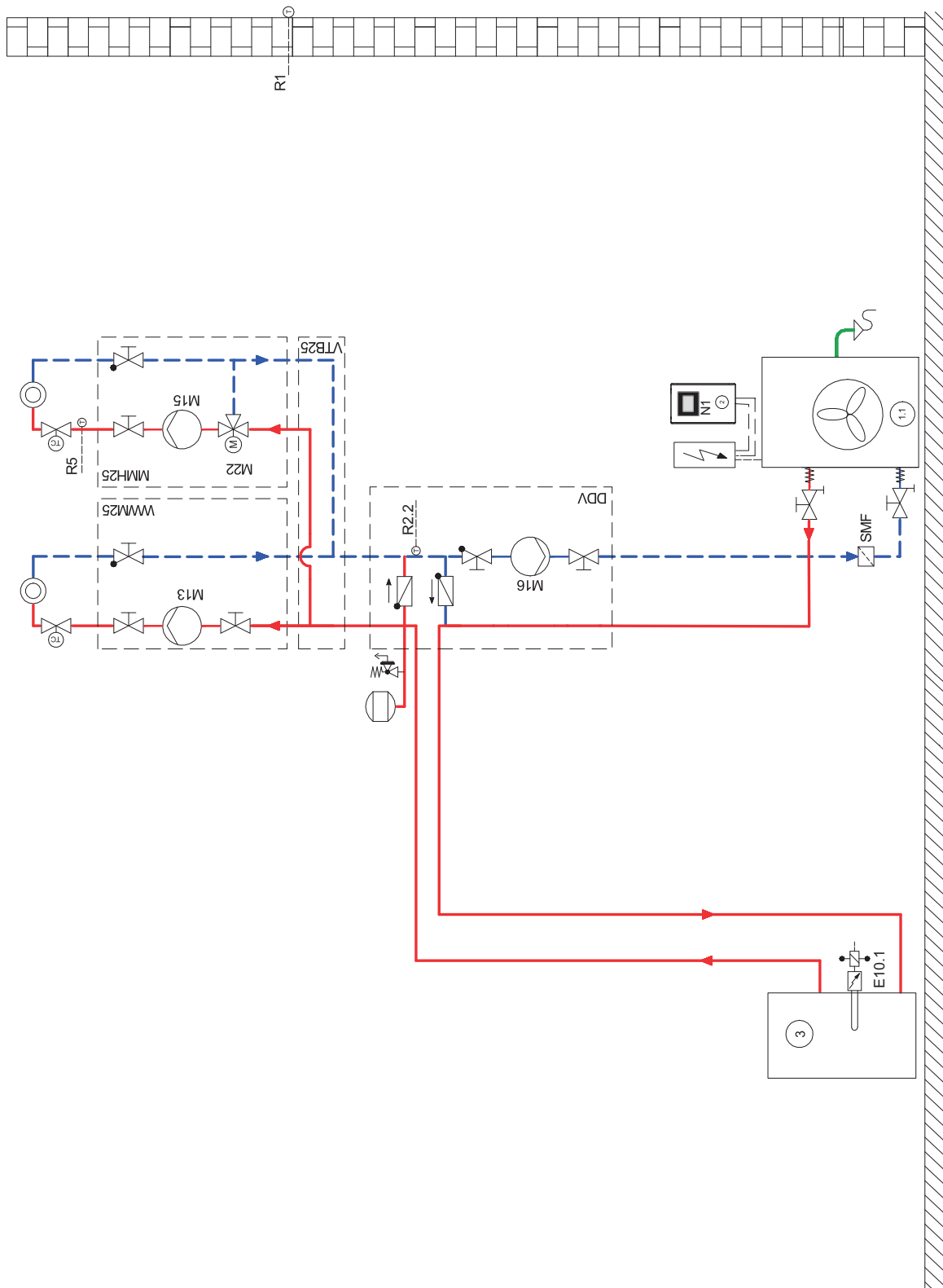

i NOTE

The hydraulic integration diagram is an example and intended only as an aid. The system requires professional and safety-approved layout by a specialist planner. All information in the section on installation and the corresponding safety notes must be observed at all times.



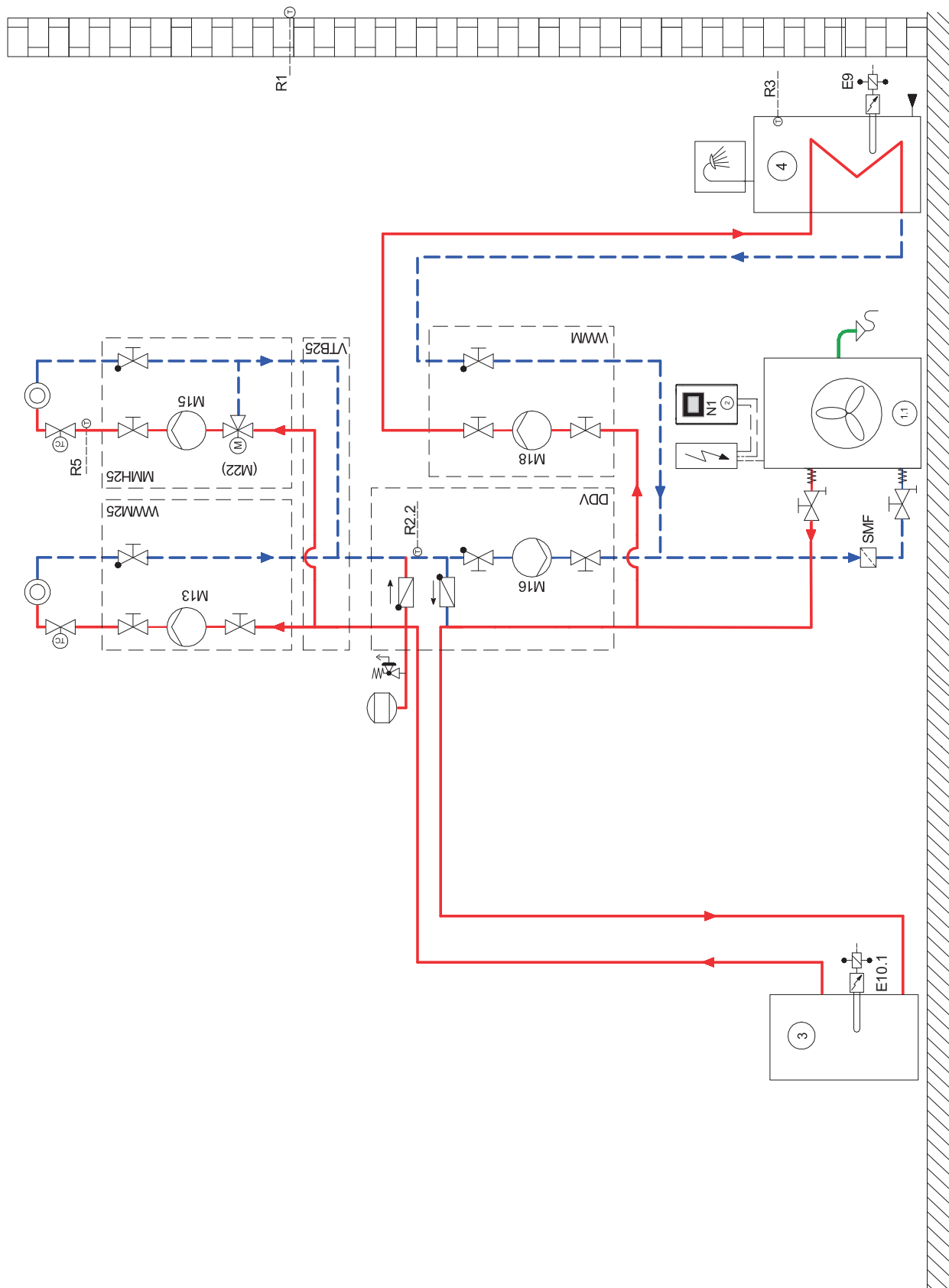















15.2 Hydraulic integration diagrams



i NOTE

The hydraulic integration diagram is an example and intended only as an aid. The system requires professional and safety-approved layout by a specialist planner. All information in the section on installation and the corresponding safety notes must be observed at all times.

15.3 Legend

	Isolating valve
	Safety valve combination
	Circulating pump
	Expansion vessel
	Room-temperature controlled valve
	Isolating valve with check valve
	Isolating valve with drainage
	Heat consumer
	Four-way reversing valve
	Temperature sensor
	Flexible connection hose
	Check valve
	Three-way mixer
	Dirt trap (optional)
	Air-to-water heat pump
	Heat pump manager
	Buffer tank connected in series
	Domestic hot water cylinder
E9	Flange heater domestic hot water
E10.1	Immersion heater
M13	Heat circulating pump main circuit
M15	Heat circulating pump for 2nd heating circuit
M16	Auxiliary circulating pump
M22	Mixer for 2nd heating circuit
N1	Heat pump manager
R1	External wall sensor
R2.2	Demand sensor
R3	Domestic hot water sensor
R5	Temperature sensor for 2nd heating circuit
SMF	Dirt trap (optional)
M18	Domestic hot water circulating pump

16 Declaration of Conformity

You can find and download the current CE conformity declaration at:

<https://dimplex.de/li1422c>

<https://dimplex.de/li1826c>



Glen Dimplex Deutschland

Head office

Glen Dimplex Deutschland GmbH
Am Goldenen Feld 18
D-95326 Kulmbach

T +49 9221 709-101
F +49 9221 709-339
info@dimplex.de
www.dimplex.de

On site service

After-sales service, technical support and spare parts. Assistance before and after installation of your equipment

T +49 9221 709-545
F +49 9221 709-924545
Mon - Thu: 7:00 to 17:00
Fri: 7:00 to 15:00
service@dimplex.de

Outside these opening times,
in an emergency you can contact
our 24/7 hotline.

Request after-sales service on the internet:
www.dimplex.de/dimplex-service