

USER MANUAL

10HYW, 15HYW, 20HYW



SAFETY WARNINGS AND PRECAUTIONS



WARNING! When using the tool, basic safety precautions should always be followed to reduce the risk of personal injury and damage to the equipment. Read all this instructions before using this tool!

1.Keep children away.

Children must never be allowed in the work area. Do not let them handle machines, tool , or extension cords.

2.Store idle equipment.

When not in use, tools must be stored in a dry location to inhibit rust. Always lock up tools and keep out of reach of children.

3.Dress Properly.

Do not wear loose clothing or jewelry as they can be caught in moving parts.Protective, electrically non-conductive clothes and non-skid footwear are recommended when working. Wear restrictive hair covering to contain long hair.

4.Use eye and ear protection.

Always wear impact safety goggles. Wear a full face shield if you are producing metal filings or wood chips. Wear a dust mask or respirator when working around metal, wood, and chemical dusts and mists.

5.Maintain tools with care.

Keep tools sharp and clean for better and safer performance.Follow instructions for lubricating and changing accessories.Inspect tools cords periodically and,if damaged, have them repaired by and authorized technician. The handles must be kept clean, dry and free from oil and grease at all times.

6.Disconnect Switch.

Unplug switch when not in use.

7.Stay alert.

Watch what you are doing, use common sense. Do not operate any tools when you are tired.

8.Check for damaged parts.

Before using any tool, any part that appears damaged should be carefully checked to determine that it will operate properly and perform its intended function. Check for alignment and binding of moving parts; any broken parts or mounting fixtures; and any other condition that may affect proper operation. Any part that is damaged should be properly repaired or replaced by a qualified technician. Do not use the tools if any switch does not turn "on" and "off " properly.

9.Replacement parts and accessories.

When servicing use only identical, salts, and rust.

10.Do not operate tool if under the influence of alcohol or drugs.

Read warning labels on prescription to determine if your judgment or reflexes are impaired while taking drugs, if there is any doubt, do not operate the tools.

WINCH WARNING AND PRECAUTIONS

1. Keep hands and body away from fairlead (cable intake slot) when operating.
2. Secure vehicle in position before using winch.
3. Be certain winch is properly bolted to a structure (or vehicle) that can hold the inch load.
4. Do not use inappropriate attachment to extend the length of the winch cable.
5. Never lift people or hoist loads over people.
6. Never come in between the winch and the load when operating.
7. Do not apply load to winch when cable is fully extended. Keep at least 5 full turns of cable on the reel.
8. After moving an item with the winch, secure the item. Do not rely on the winch to hold it for an extended period.
9. Examine winch before using. Components may be affected by exposure to chemicals, salts, and rust.
10. Never fully, extend cable while under load. Keep 5 complete turns of cable around the winch drum.
11. Never operate winch if cable shows any signs of weakening, knotted or kinked.
12. Do not cross over or under cable under load.
13. Do not move vehicle with cable extended and attached to load to pull it. The cable could snap.
14. Use glove while handling cable.
15. Apply blocks to vehicle when parking on an incline.
16. Re-spool cable properly.

UNPACKING

When unpacking, check to make sure all parts is included. Refer to winch assembly drawing and parts list (both with like item numbers) at the end of this manual.

INSTALLATION

1. Mount winch to the vehicle using high strength cap screw. It should be aligned and secured to a solid part of the vehicle (front or rear) where the full rated load will be evenly distributed.
2. Connect the two-color (positive) battery cables from the female connector to screw-down positive (+) terminal to the 12/24 volt battery.
3. Please refer to installation illustration.

Mounting the Directional solenoid valve assembly

The valve should be mounted away from any areas where heat may be considered too extreme, such as an exhaust manifold or turbo. Be sure all plumbing and wiring reaches from the area is selected without being stressed. It may be mounted by using the bracket and allen screws supplied. Using the bracket as a guide, make the

location of where the mounting holes are going to be drilled, remove the plate and drill four 1/4 holes. Mount valve assembly using nuts, bolts.

Note : on some vehicles grill may have to removed to install plumbing and wiring for the winch.

Mounting the balance valve

The balance valve supplied is simply connected to motor, if your winch system installs a balance valve as complete working mode, be sure the balance valve's installing direction meets hydraulic principle chart. Otherwise, the winch will not reach the rated line pull, and it is also dangerous for winch to power off the cable with heavy load. If this symptom happens, simply disconnect the balance valve, exchange the oil hole between hydraulic motor valve, and reconnect it, if your ordered that the balance valve should be supplied, it will have been connected with the motor at the factory.

Electrical connections

If winch's power supply is from the vehicle's exiting power steering pump, the solenoid valve system is designed default to the power steering box so power steering is always available even when the winch is in use. The power source to the solenoid is not energized until the three pole quick connector plug is plugged in. Each solenoid has two wires-either of which can be used as a ground or for electric power. The grounds are connected to each other at the factory. The other will connect to the blue and yellow wire in the harness (see illustration). Determine a location on the front grill to mount the female 3 pole plug connector. Drill a hole and mount female 3 pole plug connector using nuts, bolts and washers supplied. Connect all wiring as shown in illustrating. Test hand control unit, solenoids will make a slight "slick" sound if connected properly.

Plumbing connections

Keep all hoses away from any areas where heat may be considered too extreme such as an exhaust manifold or turbo. Lines should not be allowed to rub on any abrasive or vibrating surfaces. In some applications, 90° fittings on the directional valve and motor or balance valve are necessary to make hose mounting more flexible. After plumbing has been laid out on vehicle, install O-ring fittings supplied to valve. Torque tight. DO NOT OVERTIGHTEN ANT FITTINGS. Install O-ring fittings on winch motor. Torque tight connect any hose port A on motor or port V1 on balance valve to port A on directional valve, port B on motor or port V2 on balance valve to port B on directional valve, port P on directional valve to pump's high pressure port, port T on valve to reservoir, if necessary connect any hose port S on valve to steering box. Attach any o-ring or seal from vehicles original tube to tube fitting.

Working hydraulic principle chart:

Simple working mode

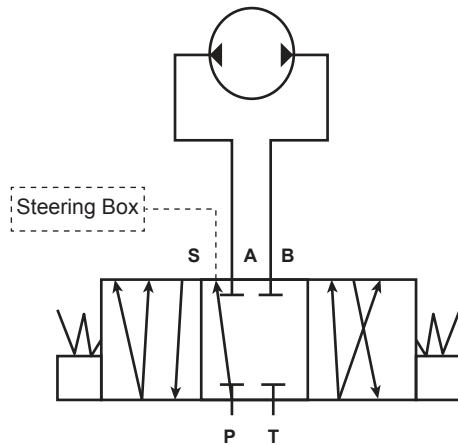

Complete working mode

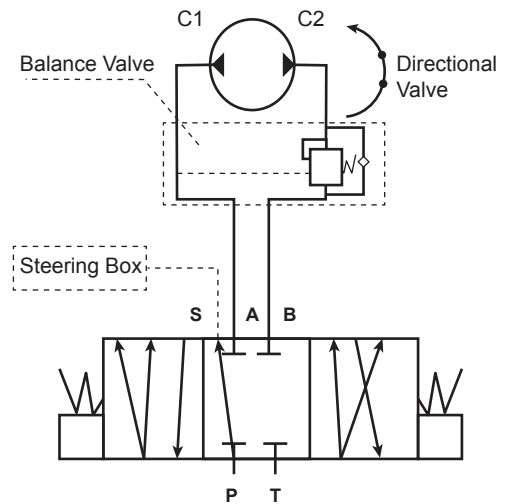

Installation illustration(Complete working mode)

1. Hydraulic power from a suitable individual pump

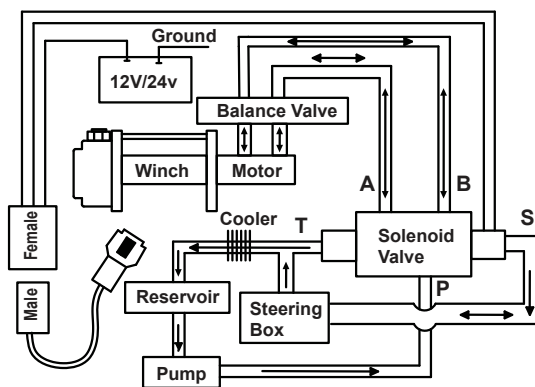

2. Hydraulic power from a combined pump

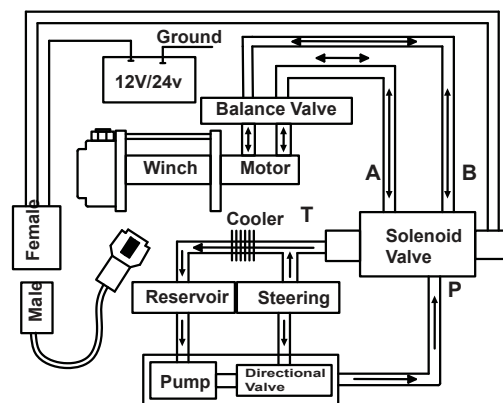

Hydraulic Wiring:

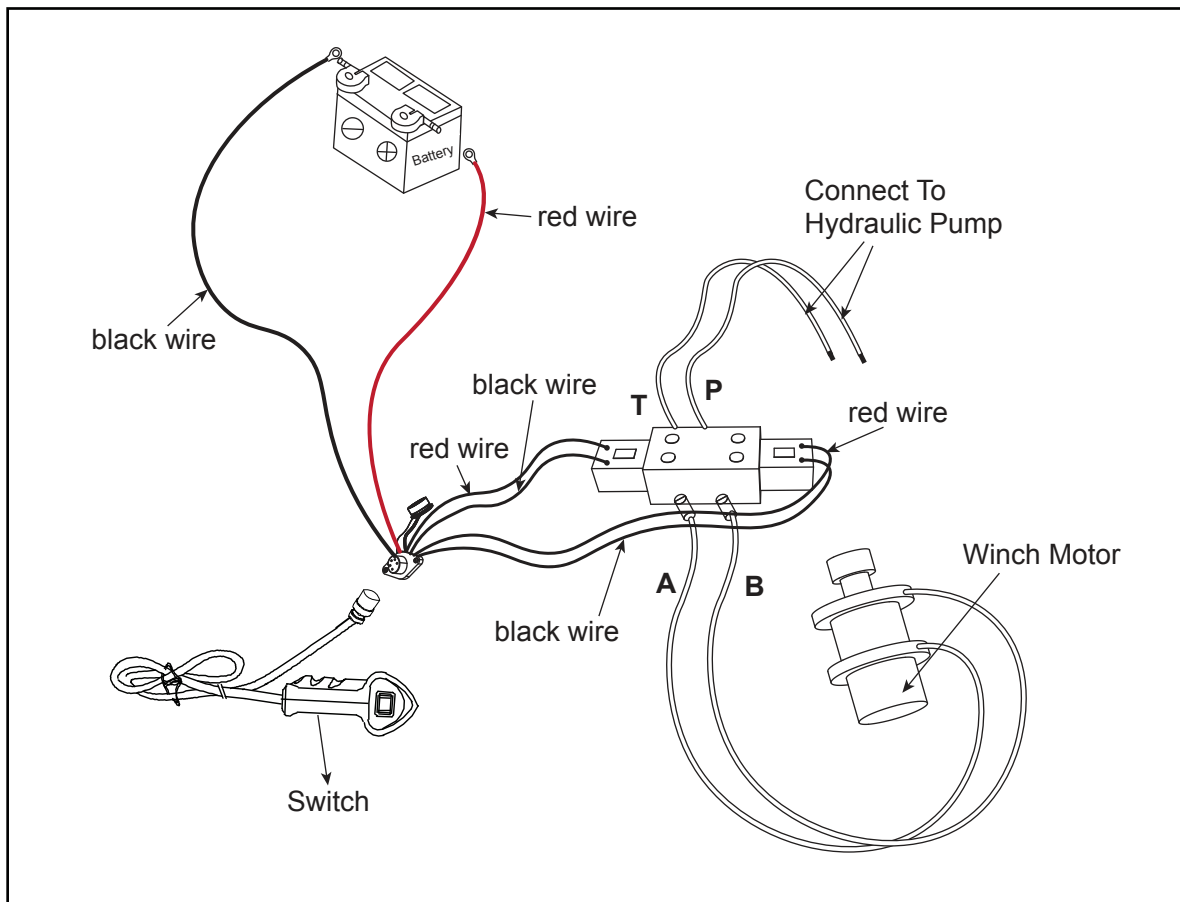

CAUTION:

- Battery cables should not be drawn taut leave for some cable movement.
- If your application is supplied with an added cooler, please refer to illustration, check fluid level. Replace lost fluid to system. System will need to be purged. Start engine. Power winch cable in 5 feet. Shut engine off. Check fluid level. (Add fluid until full, start engine, power winch cable, out 5 feet, shut engine off, check fluid level.) Add fluid until full if necessary. Start engine. Power winch cable into desired position. Turn vehicle wheels from lock to lock position 5 times. This will aid in bleeding out any air that may have got into the system.
- If the hand control until is working backwards, simply exchange the brown and white wire connectors.
- Winch cable must be wound onto the drum under a load of at least 10% rated line pull or outer wraps will draw into inner wraps and damage winch cable.
- Test winch for proper operation. Refer to the operation section, below.

WARNING

1. Make sure clutch is totally engaged before starting any winch operation;
2. Stay clear and away from raised loads;
3. Stay clear of cable while pulling do not try to guide cable;
4. A min. of 5 wraps of cable around the drum barrel.

General information

-The winch's standard equipments contain gear reducer, drum, hydraulic motor, solenoid valve, switch assembly, female connector and plumbing fitting. The winch obtains its pressure from the vehicle's existing power steering pump or other hydraulic power. The winch is totally sealed, can be used underwater.

-There are several ways to supply the pressure for winch; the first way; use an individual pump for engineering use; the second way; the winch's pressure is from the vehicle's exiting power steering pump as installation illustration: (1) Use a suitable individual pump which has not oil valve; it supply pressure for both steering box and winch. (2) Use a combined pump which integrate an oil valve together, the oil valve supply two kinds of flow for difference demand, one with constant flow is for steering use, the other with higher power is for engineering use. Refer to installation illustration. You can choice the best suitable way.

-If your winch installed as a simple working mode (standard supplied),

NEVER POWER WINCH CABLE OUT WITH HEAVY LOAD; that will be serious dangerous, if your winch installed a balance valve as a complete working mode, you can power winch cable in and out under heavy load.

1. Disengage the clutch by turning the clutch to the "OUT" position.
2. Grab the cable assembly hook and pull the cable to the desired length, then attach to item being pulled.

CAUTION: Always leave at least 5 turns of cable on the drum; review winch safety warning and precautions on page 2,3 before continuing.

3. Reengage the clutch by turn the clutch to the "in" position. If necessary to turn the drum make a slight "click" sound while engaged properly, then finger the clutch tight.
4. Lift the female connector cover exposing the electric switch connector.
5. Insert the switch assembly connector onto the female connector.
6. While standing aside of the tow path, press (and hold) the red push button on the switch assembly. Press (and hold) the opposite push button to reverse directions. Wait until the motor stops before reversing directions.
7. When the towing is complete, remove the switch assembly. From the female connector and replace the female connector cover.

MAINTENANCE

Trouble shooting

SYMPTOM	POSSIBLE CAUSE	SUGGESTED ACTION
Winch does not turn	-Electrical connections have not connected properly	-Insert switch assembly all the way into connector. -Tighter nuts on all cable connections.
Motor runs but cable drum does not turn	-The clutch is not engaged	-Turn the clutch to the "CLUTCH IN" position, if problem still persists, a qualified technician needed to check and repair.
Winch drum runs slowly or without normal power	-Insufficient pressure or oil flow -Balance valve connected with wrong direction. -Insufficient fluid in the system.	-Bump is not suitable or defective, change a new one or a suitable one. -Disconnect the balance valve; exchange the oil hole between hydraulic motor and balance valve. -Check fluid level and fluid until full.
The switch assembly working in backwards	-Electric connections are in wrong direction.	-Simply exchange the blue and yellow wire connectors at the solenoid of directional valve.

Lubrication

1. All moving parts within the winch having been lubricated using high temperature lithium grease at the factory. No internal lubrication is required.
2. Lubricate cable assembly periodically using a light penetrating oil.

Cable assembly replacement

1. Turing clutch to the "Disengaged" position.
2. Extend cable assembly to its full length. Note how the existing cable is connected to the drum.
3. Remove old cable assembly and attach new one.
4. Retract cable assembly onto drum, first five wraps being careful not allow kinking then winch cable must be wound onto the drum under a load of at least 10% rate line pull.

Winch Parts List

Item No.	Description	QTY
1	Hexagon bolt M5 x 16	10
2	Spring washer $\phi 5$	10
3	Hexagon bolt M6 x 12	1
4	T type clutch knob	1
5	Clutch spring	1
6	O-ring	1
7	Clutch handle pin	1
8	Hydraulic end cover	1
9	Non-asbestos washer	2
10	Hydraulic gear ring	1
11	Hydraulic drive shaft	1
12	Planetary gear assembly 1	1
13	Plastic washer	1
14	Planetary gear assembly 2	1
15	Hydraulic gear tube	1
16	Hexagon bolt M8 x 25	4
17	Spring washer $\phi 8$	4
18	Hydraulic gear box base	1
19	Spring washer $\phi 6$	10
20	Hexagon bolt M6 x 20	10
21	Iron bush	2
22	Waterproof ring	2
23	Hexagon socket	1
24	Hydraulic transmission shaft	1
25	Drum assembly	1
26	Tie bar	2
27	Brake assembly	1
28	Transmission bush	1
29	Hydraulic motor base	1
30	Hydraulic motor	1
31	Spring washer $\phi 12$	2
32	Hexagon bolt M12 x 30	2

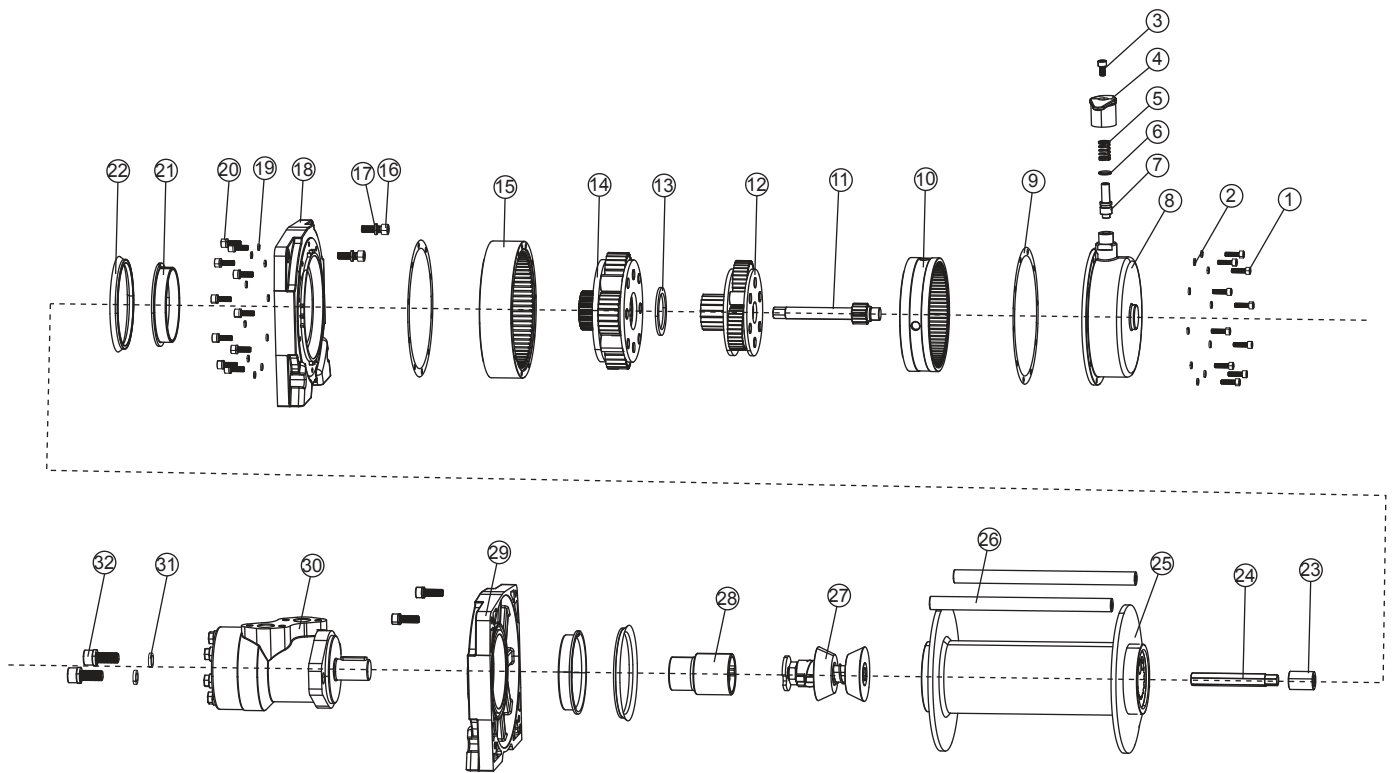

Model:10000NH

Performance specification

Single line pull: 10000lbs
 Gear ratio: 33:1
 Motor: Hydraulic motor
 Brake: Automatic brake
 Drum size: $\phi 88 \times L224\text{mm}$
 Cable: $\phi 9.5\text{mm} \times 26\text{m}$
 Mounting bolt pattern: 254mm X 114mm

Model:15000NH

Performance specification

Single line pull: 15000lbs
 Gear ratio: 33:1
 Motor: Hydraulic motor
 Brake: Automatic brake
 Drum size: $\phi 88 \times L224\text{mm}$
 Cable: $\phi 12\text{mm} \times 26\text{m}$
 Mounting bolt pattern: 254mm X 114mm

Model:20000NH

Performance specification

Single line pull: 20000lbs
 Gear ratio: 33:1
 Motor: Hydraulic motor
 Brake: Automatic brake
 Drum size: $\phi 88 \times L224\text{mm}$
 Cable: $\phi 12.7\text{mm} \times 26\text{m}$
 Mounting bolt pattern: 254mm X 114mm