

1127C PIR MOTION DETECTOR

Installation Guide

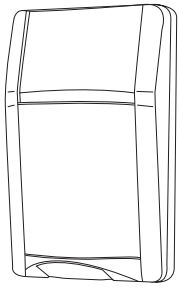

Figure 1: 1127C PIR

DESCRIPTION

The 1127C is an 1100 Series Wireless Wall Mount Curtain PIR. The Detection area is a 50' x 10' curtain using a Fresnel lens.

The PIR includes a case tamper and functionality to allow sensor configuration from the control panel. Features include Sensitivity Adjustment, Pulse Count, Walk Test, & Disarm Disable.

Compatibility

- All DMP 1100 Series Wireless Receivers and panels

What is Included?

- One PIR detector with DMP wireless transmitter
- Two CR123 batteries



1 PROGRAM THE PIR IN THE PANEL

When programming the 1127C in the panel, refer to the panel programming guide as needed.

Note: When setting up a wireless system, it is recommended to program zones and connect the receiver before installing batteries in the transmitters.

1. In **ZONE INFORMATION**, enter the wireless zone number.
2. Enter the zone name.
3. Select **NT** (Night) as the **ZONE TYPE**.
4. Select the **AREA**.
5. At the **NEXT ZN?** prompt, select **NO**.
6. Select **YES** when **WIRELESS?** displays.
7. Enter the eight-digit **SERIAL#** and press **CMD**.
8. Enter the **SUPRVSN TIME** and press **CMD**.
9. Choose whether or not to enable **DISARM DISABLE** (panel firmware Version 172 and higher only). Selecting **YES** allows the 1127 to be disabled for Night and Exit type zones while the area is disarmed.
10. At **PULSE COUNT**, choose either **2** or **4**. The pulse count is the number of pulse inputs (trips) the 1127 needs to sense before going into alarm.
11. At **SENSITIVITY**, choose either **LOW** or **HIGH**. Selecting **LOW** sensitivity may reduce false alarms for installations in harsh environments.
12. At the **NEXT ZN?** prompt, select **YES** if you are finished programming the zone. Select **NO** if you would like to access additional programming options.

When a receiver is installed, powered up, or the panel is reset, the supervision time for transmitters is reset. If the receiver has been powered down for more than one hour, wireless transmitters may take up to an additional hour to send a supervision message unless tripped, tampered, or powered up. This operation extends battery life for transmitters. A missing message may display on the keypad until the transmitter sends a supervision message.

2 INSTALL OR REPLACE THE BATTERIES

Observe polarity when installing the battery. Use only 3.0V lithium batteries, DMP Model CR123.

If the battery reaches the factory preset low level, a Low Battery signal is sent to the panel. The 1127C PIR remains operational for approximately 30 days to allow adequate time to replace the battery.

1. Remove the front cover. See Figure 2.
2. Remove the batteries (if installed) before installing new batteries.
3. Observe polarity and insert the batteries into the battery holder.

Caution: Risk of fire, explosion, and burns. Do not recharge, disassemble, heat above 212°F (100°C), or incinerate. Properly dispose of used batteries.

3 SELECT A LOCATION

Locate the Unit:

- On a rigid vibration-free surface
- Where the expected intruder movement is across the detection pattern

Do Not Locate the Unit:

- On a surface exposed to moisture
- In any area containing excessive metallic surfaces
- Where it may be exposed to false alarm sources such as: direct sunlight, heat sources (heater, radiators, etc.) in the field of view or strong air drafts (fans, air conditioner, etc.)

LED Survey Operation

The PIR transmitter provides a survey capability to allow one person to confirm transmitter communication with the receiver while the cover is removed. This allows you to easily determine the best location for the 1127C.

1. Hold the 1127C in the exact desired location.
 2. Press the tamper switch to send data to the panel and determine if communication is confirmed or faulty.
- ✓ **Confirmed:** If communication is confirmed, the survey LED under the board turns on when data is sent to the receiver and off when acknowledgement is received. To view this survey LED, turn the 1127 sideways. Repeat this test to confirm five separate consecutive LED blinks. Any indication otherwise means proper communication has not been established.
- ✗ **Faulty:** If communication is faulty, the LED remains on for about 8 seconds or flashes multiple times in quick succession. Relocate the detector or receiver until the LED confirms clear communication.

Top View

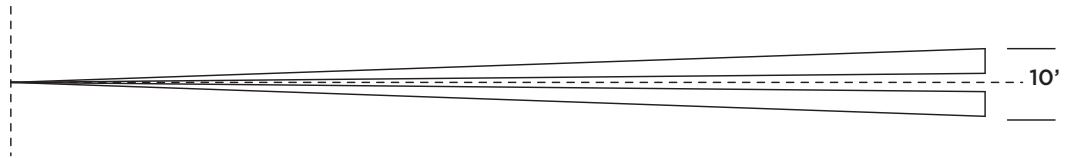

Side View

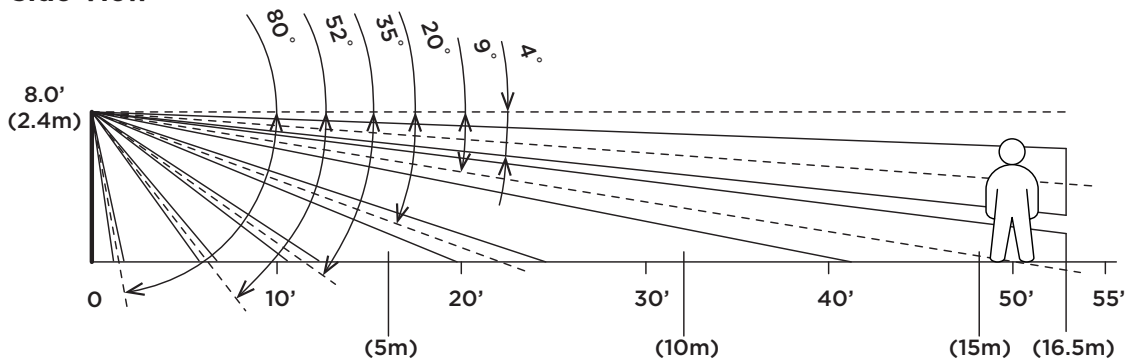

Figure 2: Detection Pattern

4 MOUNT THE DETECTOR

⚡ Caution: You must be free of static electricity before handling sensor circuit boards. Touch a grounded, bare metal surface before touching circuit boards or wear a grounding strap.

When mounting the detector, refer to Figure 3.

1. Remove the front cover from the detector.
2. Remove the batteries and the PCB from the back cover to expose mounting holes. Use your thumbs to push on the battery case to slide the PCB toward the top of the back cover and lift out.
3. Select the appropriate mounting holes on the back cover for either corner or flat wall mounting.
4. With the Cover Lock Screw toward the bottom, attach the back cover to the wall, up to 8' high, using screws and wall anchors, do not over-tighten.
5. Reinstall the PCB in the back cover in the reverse order of Step 2.
6. Reinstall the batteries and front cover.

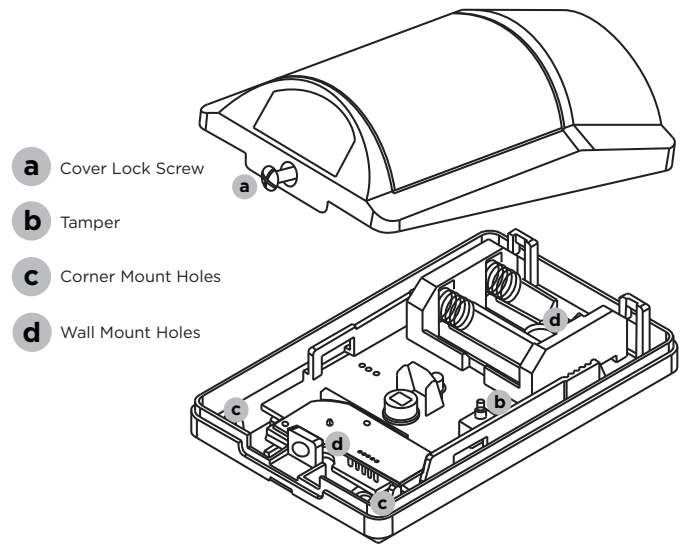

Figure 3: Remove the Cover

5 TEST THE DETECTOR

Walk Test

1. From the Walk Test menu of the panel, select the PIR Walk Test to place the PIR in walk test mode (enabling the LED) for 30 minutes. After 30 minutes, the Walk Test automatically exits and the PIR returns to normal.
Any 1127C PIR Transmitters that have **DISARM DISABLE** set to **YES** are temporarily enabled when the Walk Test is selected. Upon completion of Walk Test, the transmitter is disabled again.
2. After entering the walk test mode, thoroughly test the installation to insure proper protection pattern of the installed units. The walk test is a local test only and no results are sent to the Central Station.

Transmission Test

1. After programming the unit, close the cover to restore the tamper switch.
2. Verify that the keypad display indicates a signal received from the detector.

ADDITIONAL INFORMATION

Battery Life Expectancy

Typical battery life expectancy for a DMP Model 1127C Wireless PIR is five years, based on 300 trips per day. Battery life can be increased 40% to seven years by programming the Disarm Disable feature as **YES**. DMP wireless equipment uses two-way communication to extend battery life.

The following situation can extend battery life expectancy:

- Enabling the Disarm Disable feature in Zone Programming allows the PIR to be disabled while the area is disarmed. This eliminates frequent motion from being detected in a high traffic area during the disarmed period.
- Extend transmitter supervision time in panel programming.

The following situations can reduce battery life expectancy:

- If a receiver is unplugged or not installed.



Note: Transmitters continue to send supervision messages until a receiver returns an acknowledgement. After an hour the transmitter only attempts a supervision message every 60 minutes.

- Programming the Disarm Disable feature as **NO** where frequent transmissions, in areas of high traffic, cause messages to be sent every time movement is detected.
- When installed in extreme hot or cold environments.

Maintenance

When installed and used properly, the unit provides years of service with minimal maintenance. To ensure proper operation, perform unit testing annually as described. Clean the cover and optional bracket with a water dampened cloth as needed to keep it free of dust and dirt. Always test the unit after cleaning.

Mounting Outside

The temperature range for mounting outside is 32 - 120 ° F with a humidity at 85% at 86 ° F.

FCC INFORMATION

This device complies with Part 15 of the FCC Rules. Operation is subject to the following two conditions:

1. This device may not cause harmful interference, and
2. this device must accept any interference received, including interference that may cause undesired operation.

The antenna used for this transmitter must be installed to provide a separation distance of at least 20 cm (7.874 in.) from all persons. It must not be located or operated in conjunction with any other antenna or transmitter.

Changes or modifications made by the user and not expressly approved by the party responsible for compliance could void the user's authority to operate the equipment.

 **Note:** This equipment has been tested and found to comply with the limits for a Class B digital device, pursuant to part 15 of the FCC Rules. These limits are designed to provide reasonable protection against harmful interference in a residential installation. This equipment generates, uses and can radiate radio frequency energy and, if not installed and used in accordance with the instructions, may cause harmful interference to radio communications. However, there is no guarantee that interference will not occur in a particular installation. If this equipment does cause harmful interference to radio or television reception, which can be determined by turning the equipment off and on, the user is encouraged to try to correct the interference by one or more of the following measures:

1. Reorient or relocate the receiving antenna.
2. Increase the separation between the equipment and receiver.
3. Connect the equipment into an outlet on a circuit different from that to which the receiver is connected.
4. Consult the dealer or an experienced radio/TV technician for help.

INDUSTRY CANADA INFORMATION

This device complies with Industry Canada Licence-exempt RSS standards. Operation is subject to the following two conditions:

1. This device may not cause interference, and
2. this device must accept any interference, including interference that may cause undesired operation of the device.

This system has been evaluated for RF Exposure per RSS-102 and is in compliance with the limits specified by Health Canada Safety Code 6. The system must be installed at a minimum separation distance from the antenna to a general bystander of 7.87 inches (20 cm) to maintain compliance with the General Population limits.

Le présent appareil est conforme aux CNR d'Industrie Canada applicables aux appareils radio exempts de licence. L'exploitation est autorisée aux deux conditions suivantes:

1. *l'appareil ne doit pas produire de brouillage, et*
2. *l'utilisateur de l'appareil doit accepter tout brouillage radioélectrique subi, même si le brouillage est susceptible d'en compromettre le fonctionnement.*

L'exposition aux radiofréquences de ce système a été évaluée selon la norme RSS-102 et est jugée conforme aux limites établies par le Code de sécurité 6 de Santé Canada. Le système doit être installé à une distance minimale de 7,87 pouces (20 cm) séparant l'antenne d'une personne présente en conformité avec les limites permises d'exposition du grand public.

1127C

Specifications

Battery

Life Expectancy 5 to 7 years
Type 3.0V CR123

See *Battery Life Expectancy* for details.

Transmit condition Alarm, Low Battery

Mounting height 8 feet

Frequency Range 905-924 MHz

Dimensions 2.70" W x 1.77" D x 4.33" H
6.86 W x 4.50 D x 11.00 H cm

Color White



Ordering Information

1127C-W Curtain PIR
CR123 3.0V battery

Patents

U.S. Patent No. 7,239,236

Certifications

FCC Part 15: CCKPC0152

Industry Canada: 5251A-PC0152

Underwriters Laboratory (UL) Listed

ANSI/UL 639 Intrusion Detection Unit Accessory
ANSI/UL 1023 Household Burglar Alarm System Units Accessory



Designed, engineered, and
manufactured in Springfield, MO
using U.S. and global components.

LT-1062 1.03 20235

© 2020

INTRUSION • FIRE • ACCESS • NETWORKS

2500 North Partnership Boulevard
Springfield, Missouri 65803-8877

800.641.4282 | DMP.com