

1100DI IN-LINE WIRELESS RECEIVER

Installation Guide

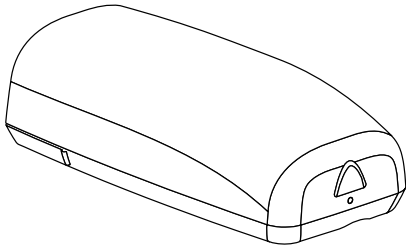

Figure 1: 1100DI In-Line Receiver

DESCRIPTION

The 1100DI provides two-way, supervised communication using 900 MHz frequency hopping spread spectrum technology. The 1100DI In-Line Wireless Receiver provides up to 32 wireless zones for XT30/XT50 Series Version 102 or higher.

The compact design allows the receiver to be installed anywhere along the panel keypad bus, such as next to a keypad. The wireless system is designed so only one 1100 receiver is used per panel.

Compatibility

- XT30/XT50 Series panels with firmware Version 102 or higher
- For wireless compatibility, refer to the DMP 1100 Series Wireless Compatibility Guide (LT-1029)

What is Included?

- One Model 1100DI Wireless Receiver with housing
- One 4-wire harness
- Hardware pack



1 PROGRAM THE PANEL

Refer to the panel programming guide as needed. After completing each of the following steps, press **CMD** to advance to the next prompt.

1. At a keypad, enter **6653** (PROG) to access the Programmer menu.
2. At **SYSTEM OPTIONS**, program a **HOUSE CODE** between 1 and 50. After turning on the house code, an XT50 will display **RECEIVER NO YES**. Select **NO**. XT30 Series panels can only work with external receivers. For more information, refer to "House Code Explained".
3. Press **CMD** until **STOP** displays. Press a top row select key or area to save programming.

2 WIRE AND MOUNT THE RECEIVER

Refer to Figure 2 when mounting and wiring the receiver.

1. Remove the cover from the plastic housing.
2. Connect one end of the wire harness to the 1100DI bus header. Connect the other end to the panel Keypad Bus.
3. Use the included screw to secure the 1100DI to the wall.
4. Snap the cover back on to the base.

3 SELECT A LOCATION

The receiver should be centrally located between 1100 Series transmitters used in the installation and no more than 500 feet (152 meters) away from the panel. Use an 1106 Series Universal Wireless Transmitter to perform an LED survey.

1. With the cover removed, hold the transmitter in the desired location.
2. Press the tamper switch to send data to the panel and determine if communication is confirmed or faulty.

✓ **Confirmed:** If communication is confirmed, for each press or release of the tamper switch, the LED blinks immediately on and immediately off.

✗ **Faulty:** If communication is faulty, the LED remains on for about 8 seconds or flashes multiple times in quick succession. Relocate the receiver until the LED confirms clear communication.

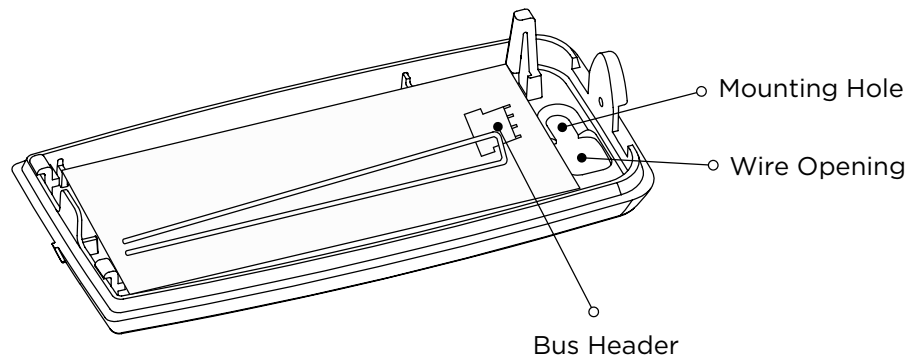

Figure 2: PCB and Mounting Holes

ADDITIONAL INFORMATION

Wiring Specifications

DMP recommends using 18 or 22 AWG for all LX-Bus and Keypad Bus connections. The maximum wire distance between any module and the DMP Keypad Bus or LX-Bus circuit is 10 feet. To increase the wiring distance, install an auxiliary power supply, such as a DMP Model 505-12. Maximum voltage drop between a panel or auxiliary power supply and any device is 2.0 VDC. If the voltage at any device is less than the required level, add an auxiliary power supply at the end of the circuit.

To maintain auxiliary power integrity when using 22-gauge wire on Keypad Bus circuits, do not exceed 500 feet. When using 18-gauge wire, do not exceed 1,000 feet. Maximum distance for any bus circuit is 2,500 feet regardless of wire gauge. Each 2,500 foot bus circuit supports a maximum of 40 LX-Bus devices.

For additional information refer to the LX-Bus/Keypad Bus Wiring Application Note (LT-2031) and the 710 Bus Splitter/ Repeater Module Installation Guide (LT-0310).

LED Operation

Two LEDs display receiver operation and activity.

- Green LED: Flashes to indicate data is being sent to the panel.
- Red LED: Steady to indicate memory upload. Off when upload is complete.

House Code Explained

The house code identifies the panel, receiver, and transmitters to each other. The 1100DI automatically sends the specified house code to wireless transmitters when transmitter serial numbers are programmed into the panel. The receiver only listens for transmissions using the specified house code or the programmed transmitters' serial numbers.

Transmitter Supervision Time

For Listed installations, program the transmitter supervision time in panel zone programming as listed in Table 1. Refer to the panel programming guide for complete wireless programming information.

COMPLIANCE LISTING	LISTED ACCESSORIES	SUPERVISION TIME
UL 268 Smoke-Automatic Fire Detectors	<ul style="list-style-type: none"> • 1100R Repeater • 1164 Wireless Synchronized Smoke Detector 	3
UL 365 Police Station Connected Burglar Accessory	<ul style="list-style-type: none"> • 1100R Repeater • 1103 Universal Transmitter 	60
UL 521 Heat Detectors for Fire Protective Signaling Systems	<ul style="list-style-type: none"> • 1100R Repeater • 1183-135F, 1183-1353R Heat Detector 	3
UL 609 Local Burglar Alarm Units and System Accessory	<ul style="list-style-type: none"> • 1100R Repeater • 1103 Universal Transmitter 	60
UL 634 Connections and Switches for use with Burglar Alarm Systems Accessory	<ul style="list-style-type: none"> • 1100R Repeater • 1101, 1102, 1103, 1106 Universal Transmitters 	60
UL 636 Holdup Alarm Units and Systems Accessory	<ul style="list-style-type: none"> • 1142 Two-Button Holdup Transmitter 	60
UL 639 Intrusion Detection Units Accessory	<ul style="list-style-type: none"> • 1100R Repeater • 1127W, 1127C PIR Motion Detectors 	60
UL 985 Household Fire Warning System Accessory	<ul style="list-style-type: none"> • 1100R Repeater • 1135 Wireless Sounder • 9060, 9063 Wireless Keypads 	240
UL 1023 Household Burglary System Units Accessory	<ul style="list-style-type: none"> • 1100R Repeater • 1101, 1102, 1103, 1106 Universal Transmitters • 1127W, 1127C PIR Motion Detectors • 1135 Wireless Sounder • 1142 Two-Button Holdup Transmitter • 9060, 9063 Wireless Keypads • 9862 Wireless Graphic Touchscreen Keypad 	60
UL 1076 Proprietary Burglar Alarm Units Accessory	<ul style="list-style-type: none"> • 1100R Repeater • 1103 Universal Transmitter • 9862 Wireless Graphic Touchscreen Keypad 	60
UL 1610 Central Station Burglar Alarm Units Accessory	<ul style="list-style-type: none"> • 1100R Repeater • 1103 Universal Transmitter • 1135 Wireless Sounder • 9060, 9063 Wireless Keypads • 9862 Wireless Graphic Touchscreen Keypad 	60
UL 2075 Gas and Vapor Detectors and Sensors	<ul style="list-style-type: none"> • 1184 Wireless Carbon Monoxide Detector 	240

Table 1: Wireless Transmitter Supervision Times

FCC INFORMATION

This device complies with Part 15 of the FCC Rules. Operation is subject to the following two conditions:

1. This device may not cause harmful interference, and
2. this device must accept any interference received, including interference that may cause undesired operation.

The antenna used for this transmitter must be installed to provide a separation distance of at least 20 cm (7.874 in.) from all persons. It must not be located or operated in conjunction with any other antenna or transmitter.

Changes or modifications made by the user and not expressly approved by the party responsible for compliance could void the user's authority to operate the equipment.

 **Note:** This equipment has been tested and found to comply with the limits for a Class B digital device, pursuant to part 15 of the FCC Rules. These limits are designed to provide reasonable protection against harmful interference in a residential installation. This equipment generates, uses and can radiate radio frequency energy and, if not installed and used in accordance with the instructions, may cause harmful interference to radio communications. However, there is no guarantee that interference will not occur in a particular installation. If this equipment does cause harmful interference to radio or television reception, which can be determined by turning the equipment off and on, the user is encouraged to try to correct the interference by one or more of the following measures:

1. Reorient or relocate the receiving antenna.
2. Increase the separation between the equipment and receiver.
3. Connect the equipment into an outlet on a circuit different from that to which the receiver is connected.
4. Consult the dealer or an experienced radio/TV technician for help.

INDUSTRY CANADA INFORMATION

This device complies with Industry Canada Licence-exempt RSS standards. Operation is subject to the following two conditions:

1. This device may not cause interference, and
2. this device must accept any interference, including interference that may cause undesired operation of the device.

This system has been evaluated for RF Exposure per RSS-102 and is in compliance with the limits specified by Health Canada Safety Code 6. The system must be installed at a minimum separation distance from the antenna to a general bystander of 7.87 inches (20 cm) to maintain compliance with the General Population limits.

Le présent appareil est conforme aux CNR d'Industrie Canada applicables aux appareils radio exempts de licence. L'exploitation est autorisée aux deux conditions suivantes:

1. *l'appareil ne doit pas produire de brouillage, et*
2. *l'utilisateur de l'appareil doit accepter tout brouillage radioélectrique subi, même si le brouillage est susceptible d'en compromettre le fonctionnement.*

L'exposition aux radiofréquences de ce système a été évaluée selon la norme RSS-102 et est jugée conforme aux limites établies par le Code de sécurité 6 de Santé Canada. Le système doit être installé à une distance minimale de 7,87 pouces (20 cm) séparant l'antenne d'une personne présente en conformité avec les limites permises d'exposition du grand public.

1100DI IN-LINE WIRELESS RECEIVER

Specifications

Operating Voltage	8.0 to 14.0 VDC
Current Draw	45 mA
RF Power Rating	13 mW
Frequency Range	905-924 MHz
Dimensions	3.3" L x 1.6" W x 1.2" H 8.4 cm W x 4.1 cm H x 3.0 cm D
Housing Material	Flame retardant ABS

Ordering Information

1100DI-W In-Line Wireless Receiver, white

Patents

U. S. Patent No. 7,239,236

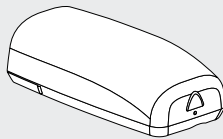

Certifications

California State Fire Marshal (CSFM)

FCC Part 15 Registration ID CCKPC0111

Industry Canada Registration ID 5251A-PC0111

Intertek (ETL) Listed

ANSI/UL 365	Police Station Connected Burglar
ANSI/UL 609	Local Burglar Alarm Units and Systems
ANSI/UL 634	Connections and Switches for use with Burglar Alarm Systems Accessory
ANSI/UL 639	Intrusion Detection Units Accessory
ANSI/UL 1023	Household Burglar Alarm System Units
ANSI/UL 1076	Proprietary Burglar Alarm Units
ANSI/UL 1610	Central Station Burglar Alarm Units
ANSI/UL 985	Household Fire Warning System



Designed, engineered, and manufactured in Springfield, MO using U.S. and global components.

LT-0962 1.07 20092

INTRUSION • FIRE • ACCESS • NETWORKS

2500 North Partnership Boulevard
Springfield, Missouri 65803-8877

800.641.4282 | DMP.com